

SPX[®]



> Marley[®]

Class F400 Cooling Tower



Proven Design

Improved Structural Materials

The Marley industrial counterflow cooling tower has proven itself as one of the most efficient and reliable designs ever. The F400 cooling tower is a logical engineered evolution of this proven design, making use of pultruded fiberglass shapes as structural members.

Proven through years of successful chemical plant construction, pultruded fiberglass is ideal for the wet, corrosive cooling tower environment. It's strong like steel but at a fraction of the weight. Yet, it will not corrode from chemical exposure or moisture, and it resists deterioration from sunlight.



Design Integrity

The F400 cooling tower elevates the proven Marley structural design to an even higher level of dependability and performance.

■ Theory Equals Performance

The engineering properties of Marley fiberglass structural members are predictable and consistent. Laboratory testing verifies the structural designs before their application in cooling towers.

■ Quality Structural Connections

Bolted, non-glued design provides the highest reliability under the most adverse conditions. Stainless steel fasteners are used throughout the F400 in conjunction with bearing sleeves to minimize fiberglass shear stress in the bolted joints.

■ Permanent Structural Stability

Marley structural designs reflect the actual conditions of heat, moisture and dynamic loading encountered in cooling towers. These structures are up to the task!

Design Flexibility

F400 towers are available in numerous basic cell sizes. Length and width may vary in 6'-0" increments. Tower height, fill height, and fill density are also variable.

Within each cell size, our designers can choose from numerous possible component combinations. Several options may result in economical selections capable of the thermal performance requirements, but only one will optimally satisfy the fan horsepower, pump head, plan area, and other evaluation parameters contained in your specifications.



Our design engineers use the Total System Approach to review each cooling tower application to assure that the components selected will work together as an integrated system for efficient performance and long life—the proven systematic approach to cooling tower design.



Total System Approach—Our proven systematic approach to cooling tower design.

■ Fast, Efficient Construction

All parts are cut and predrilled to exact specifications at Marley factories.

■ Safety and Strength

The F400 fandeck is constructed of Marley DuraLast textured pultruded fiberglass panels with integrated, hidden stainless fasteners, providing an anti-slip, safe walking surface.

■ Architectural Casing

Options include Marley DuraLast pultruded casing with integrated, hidden stainless fasteners and enclosed fandeck or durable V-Rib FRP casing.

■ Tested and Proved Fan Designs

Marley fans are designed using test data from wind tunnel modeling at the SPX Cooling Technologies Research and Development Center and are performance verified at operating installations, ensuring performance as specified.

■ Peak Fan Performance

Marley FRP fan cylinders feature venturi shaped eased inlets and close blade tip clearances.

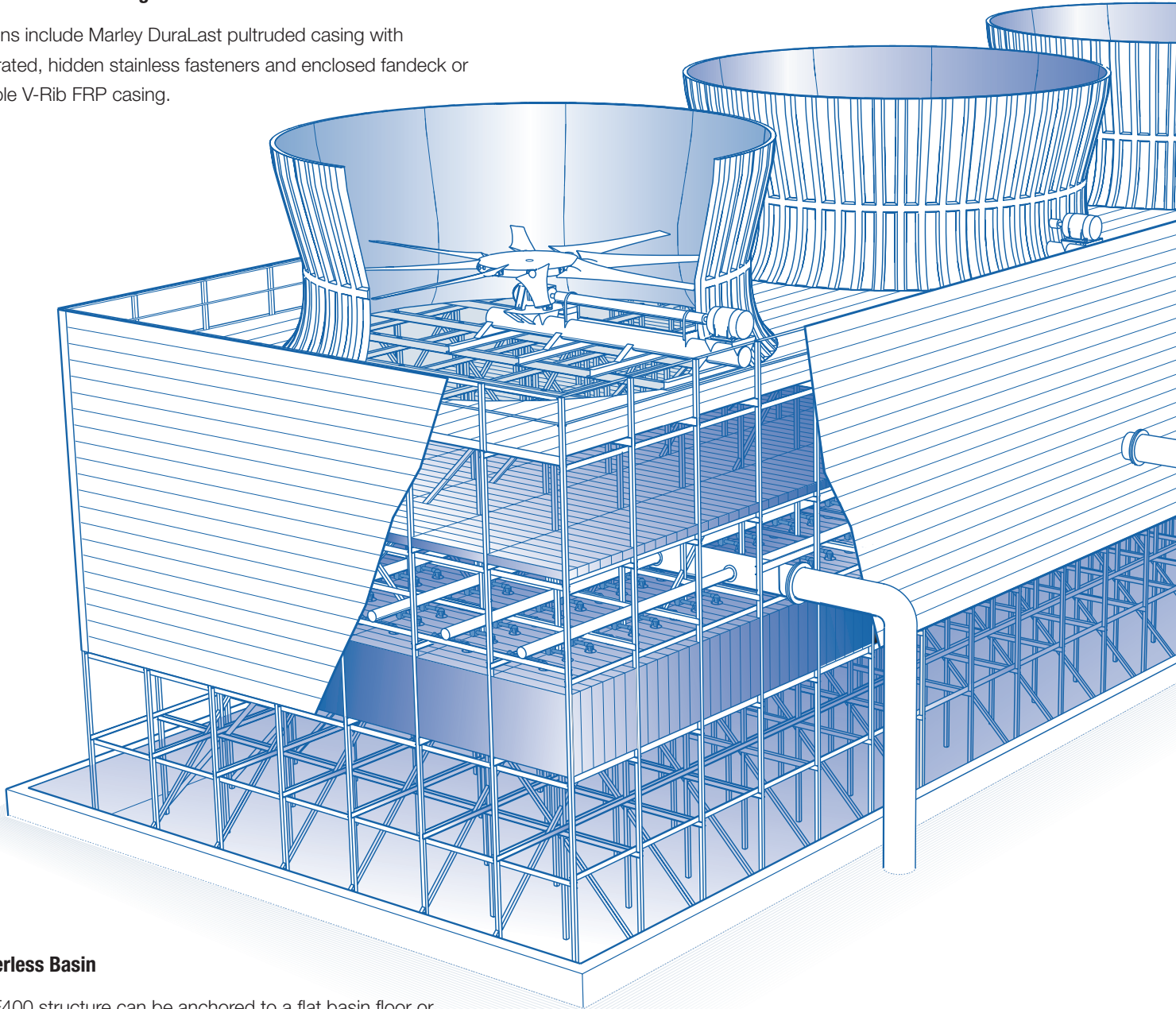

■ Pierless Basin

The F400 structure can be anchored to a flat basin floor or designed to fit existing basins. Fewer piers mean lower basin cost.

■ Low Drift Rates

Marley XCEL® cellular PVC eliminators offer the lowest drift rates in the industry. XCEL eliminators significantly lower air pressure losses, reducing fan horsepower requirements thus saving energy costs.

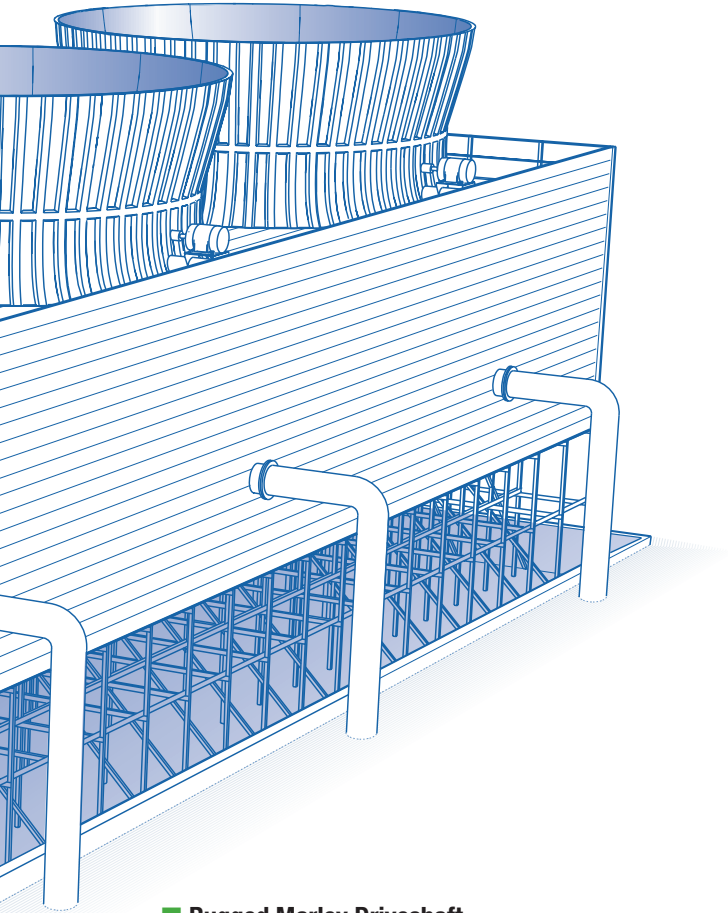

■ Rugged Marley Driveshaft

Built from stainless steel or carbon fiber composite tubes with stainless steel flanges. All Marley Driveshafts are dynamically balanced at the factory to minimize operating vibration resulting in smooth, long lasting fan operation.

■ Simple Maintenance

Each Geareducer is equipped with an oil level gauge outside of the fan cylinder near the motor. Service fittings at the gauge facilitate changing Geareducer oil.

■ Completely Bolted Structure

Marley F400 fiberglass structures are completely and securely assembled using mechanical stainless fasteners without the use of adhesives. Benefits of a bolted structure are:

Assembly can be done in the cold or wet weather—adhesives are not recommended below 40°F plus the surface must be dry before gluing.

Every joint is guaranteed to be as specified whereas a glued joint is only as good as the preparation made prior to the assembly.

If any member has to be replaced for any reason, it's a simple matter of unbolting the structure and adding the new part.

■ Tough High-Performance Film Fill

Marley high-performance fill removes process heat efficiently and predictably. PVC fill sheets are thermoformed at Marley factories to exacting quality and strength standards. Maximum performance fill designs and clog resistant fill designs are available for a wide range of thermal and water quality requirements. Our design engineers evaluate each cooling tower application individually using computer optimization analysis to select the best fill system, maximizing thermal performance—and keeping power consumption to a minimum.

■ Clog-Resistant NS Nozzles

NS nozzles are the heart of the F400 water distribution system assuring unimpeded, uniform flow with minimal operating pump head. Large diameter NS nozzles free you from the expense and nuisance of cleaning clogged, overly-complicated nozzle designs. The NS nozzle has a consistent “solid-cone” downspray pattern to assure uniform distribution coverage at pressures as low as two feet of water.

■ Durable Marley Geareducer

The industry quality standard. Designed to meet and exceed the requirements of CTI STD-111 and AGMA standards. Every Geareducer is run-in under load at the factory. Numerous reduction ratios are available so that horsepower is applied at optimum fan speed.

Combining over 80 Years of Cooling Tower Experience With over 50 Years of Fiberglass Experience

Marley began using composites in cooling towers in the early 1950s, when they were considered “exotic materials”. In fact, Marley’s work with what was then called GRP (glass-reinforced polyester) was so extensive that we were issued a registered trademark for GRP in 1960. Since then, commercial formulations have been generically known as FRP (fiber-reinforced polyester).

Through a process called pultrusion, fiberglass components can be produced to even higher standards. Components in the F400 cooling tower meet the stringent Marley requirements for consistent strength and predictable performance.

Pultruded structural components are used throughout the F400 cooling tower to produce an engineered framework of unsurpassed quality, reliability and safety. And, the F400’s structural components will always be available for simple, economic repairs.

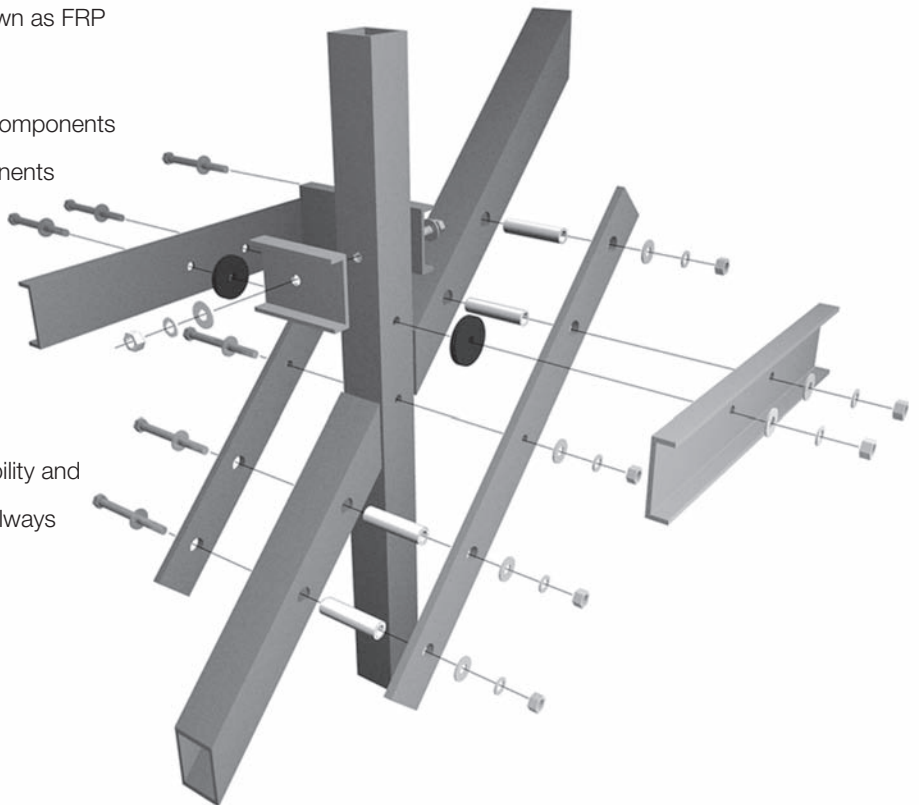

Fiberglass Pultrusion Fits The Marley “Total Systems” Approach

The pultrusion process produces a product with definite, predictable, and measurable performance. Extensive laboratory, university, and field testing for long-term effects of deflection, bending, shear, buckling, and temperature has enabled us to simulate and evaluate its performance.

Advantages of pultrusion structural members:

■ High Strength

Structural pultrusions approximate the strength of steel in tension and compression.

■ Light Weight

80% less than steel, 30% less than aluminum.

■ Corrosion Resistance

Impervious to a broad range of corrosive materials; immune to deterioration.

■ Quality Construction

Cut and predrilled to exact specifications at Marley factories, fiberglass pultrusions will not warp, twist, or split after fabrication which simplifies field assembly and component replacement. And, tower construction is safe, reliable and efficient using pultruded structural components.

■ Wet/Dry Operation

Fiberglass is perfect for “cycled” cooling towers as it is naturally impervious to splitting and checking.

■ Non-Conductive

Reduces the hazard of electrical shock compared with metal structure towers.

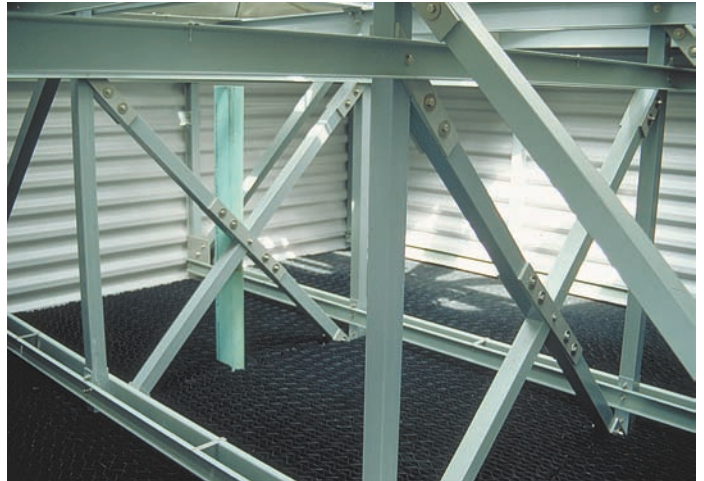

■ No Preservative Treatment Chemicals

are used in the cooling tower structure.

■ Fire-Resistant Formulations

are available as an option.

At Your Service

SPX Cooling Technologies offers a variety of additional services to owners of cooling towers worldwide. Services include:

- Application/Sizing/Layout
- Construction
- Parts
- Maintenance
- Condition Evaluation
- Reconstruction
- Performance Enhancement
- Tower Replacement

If we can help you in any way, please feel free to call SPX Cooling Technologies' world headquarters. By calling 913 664 7400, we'll put you in touch with a Marley sales representative in your area or you can find your Marley sales representative on the internet at spxcooling.com.

The Marley Difference

The companies that form SPX Cooling Technologies, Inc have over 120 years of cooling tower experience. Today, we have towers of every size and shape in over 75 countries worldwide.

Everything about your Marley cooling tower will be designed as an integrated system. Marley's "Total Systems" approach includes proven in-house capability to develop your tower from analysis of needs to every step in between.

Best of all, because Marley cooling towers are designed, constructed, and backed up as an integrated system, every component is warranted by a single supplier, SPX Cooling Technologies, Inc.

Product Specifications

Product Specifications SPEC F-400 detail the tower in the form of specification language and provide technical as well as common-sense information on the importance of your specifications. See your Marley sales representative for a copy or download from the web at spxcooling.com.



SPX[®]

SPX COOLING TECHNOLOGIES, INC
7401 WEST 129 STREET
OVERLAND PARK, KANSAS 66213
UNITED STATES
913 664 7400
spxcooling@spx.com
spxcooling.com

In the interest of technological progress, all products are subject to design and/or material change without notice.
©2012 SPX Cooling Technologies, Inc.
Printed in USA | F400-05A