

# TECHNICAL REPORT



**SUBJECT:**

## **External Influences on Cooling Tower Performance**

### **Foreword**

Owners and their system designers, quite naturally, want a specified cooling tower to perform as expected. Otherwise, the system served by the tower will suffer. Therefore, they are meticulous in determining the imposed heat load; the preferred water flow rate; the required cold water temperature; and a design wet-bulb temperature which they anticipate will seldom be exceeded.

The manufacturer, equally concerned, wants full-rated performance from his cooling tower in order to maintain his reputation—and that of the industry. Given the established design parameters with which to work, he too is meticulous in the selection of a proper cooling tower, type and size; the calculation of a required air flow rate; and the application of sufficient fan horsepower to assure delivery of that quantity of air through the tower.

Why, then, do a significant number of cooling towers appear to be performing inadequately in spite of this dedication by both the user and the manufacturer? In many cases, the problem can be traced to environmental factors which affect the quantity and/or thermal quality of the air entering the tower. This report will describe situations contributing to a poor air supply, and will suggest the preplanning necessary to ameliorate those situations.

A cooling tower reacts much like a human being to its air supply. If it is caused to reinhale its own exhaust, it begins to smother. If that air supply is restricted, it begins to choke. However, a tower is unlike a human being in two very important ways: it cannot walk away from a jeopardizing situation; and it has a propensity to contribute to its own demise.

## Recirculation

Mother Nature, in her infinite wisdom, made man's breathing pattern such that exhaust air is given a moment to disperse before a fresh supply is inhaled. Conversely, a cooling tower's respiration is continuous. It discharges warm, saturated air into the very atmosphere from which it attempts to draw cool, relatively dry air. Occasionally, part of the discharge air will "recirculate" into the entering air stream, and the system begins to experience problems associated with elevated water temperatures.

The net result of recirculation is an unexpected rise in wet-bulb temperature of the air entering the cooling tower, and a corresponding increase in the temperature of the water leaving the tower. Depending upon the severity of the recirculation, cold water temperatures can be caused to increase one to five degrees, or more. At best, this causes the system to operate above design parameters. At worst, system tolerance may be exceeded, causing shutdown to become necessary. Accordingly, it behooves cooling tower users to be aware of this phenomenon, and to know the measures to take to minimize its impact.

All cooling towers offer the potential for recirculation, the extent of which depends primarily upon the entering and exiting air velocities—and their relationship to each other. Higher entering velocities increase the potential for recirculation, while higher exit velocities decrease its opportunity. This is because higher entering velocities result in an increased low-pressure zone at the air intake, into which exhaust vapor can be induced; whereas higher exiting velocities tend to propel the discharge vapors beyond the influence of the intake area's low-pressure zone.

Cooling tower types representing opposite ends of the scale for recirculation potential are depicted in Figures 1 and 2. In the induced draft tower (Fig. 1), exhaust air is propelled upward by the fan at an imparted velocity of approximately 2000 ft/min, while fresh air is drawn into the air intakes at a velocity less than 700 ft/min. This velocity relationship gives reasonable assurance that the tower will be subjected to very little self-imposed recirculation. (As will be seen, however, external influences can adversely affect even the best of design intentions.)

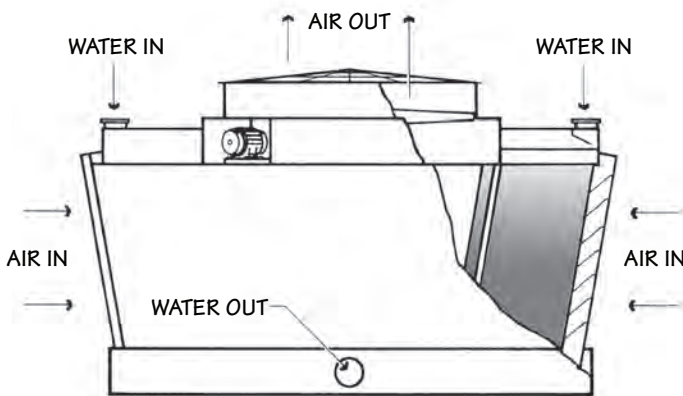

Figure 1—Cut-away of an Induced Draft Tower

The velocity relationships in the forced draft tower (Fig. 2) are essentially the reverse of those encountered in the induced draft tower. Air enters the fan region at velocities usually exceeding 2000 ft/min, and exits the top of the tower at velocities normally less than 700 ft/min. This high entrance velocity creates a significant low-pressure zone at the intake, in which a portion of the exhaust air is likely to be captured.

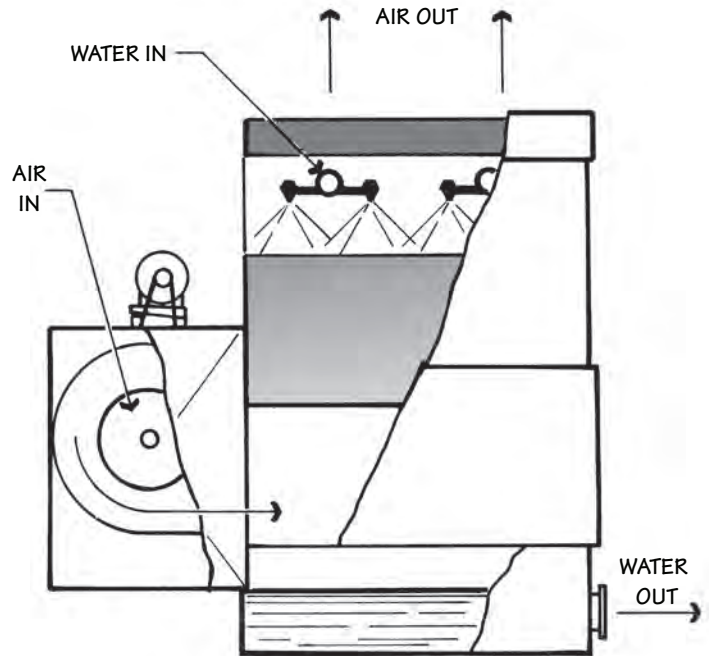

Figure 2—Cut-away of a Forced Draft Tower  
(extended fan-section style)

## Air Restriction

At a given heat load, a fixed water flow rate, and a particular wet-bulb temperature, the cold water temperature produced by a cooling tower is totally dependent upon the quantity of entering air. Decrease the amount of air flow and the cold water temperature will rise. Because of the importance of air flow, manufacturers are painstaking in their calculation of the amount required to meet specified performance, and in the application of a fan/motor combination which will move that quantity of air against the static pressure encountered within the tower.

Static pressure is the measure of a system's resistance to a given flow of air. It results from restrictions in the system (which increase the air's velocity), and from changes in the direction of air flow. Within the cooling tower are many restrictions to air flow (fill, drift eliminators, piping, structure, etc.), and a multitude of directional changes. These combine to produce a total net static pressure which determines the fan horsepower applied by the manufacturer. If something should happen to cause an increase in the static pressure, air flow through the tower will decrease—and a higher cold water temperature will result.

## External Influences

Having defined the recirculation-which smothers a cooling tower, and the imposition of static pressure- which chokes it, we can now look at two primary external influences which affect these conditions. Namely, wind and air obstructions.

### Wind

Wind, depending upon its speed and direction, tends to magnify a cooling tower's potential to recirculate. Not only does it bend the exhaust air stream in the direction of wind flow, it also creates a low-pressure zone at the lee (downwind) side into which a portion of the saturated "plume" may be drawn. If the downwind side of the tower happens to be an air inlet face, then that portion of the plume can be expected to thermally contaminate the entering air.

The degree to which wind can affect plume rise depends upon the ratio of a cooling tower's discharge (jet) velocity ( $V_j$ ) compared to the velocity of the ambient wind ( $V_a$ ). Figure 3, for example, depicts the behavior of a plume as it leaves the fan cylinder of an induced draft tower and encounters a wind of equal velocity—approximately 20 mph. Not shown (for reasons of scale) is the depression of some affected portion of this plume into the tower's lee side low-pressure zone.

Fortunately, since most induced draft towers (Fig. 1) have separate air inlets on opposite faces, recirculation will normally affect but one inlet at time, and its net effect tends to be

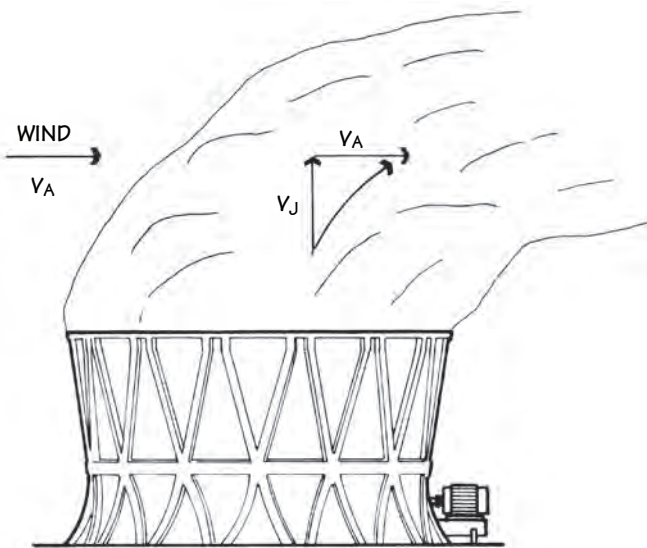

Figure 3—Effect of Wind on Plume Behavior

minimized. Nevertheless, it is sufficient to have warranted studies, resulting in the recirculation-potential curve shown in Figure 4. This curve plots percent of net recirculation as a function of the ratio of discharge velocity ( $V_j$ ) to ambient wind velocity ( $V_a$ ). It was developed for towers of rectangular configuration (Figs. 1 and 2), but having air inlet faces on two opposite sides of the tower. Therefore, the indicated

recirculation ratio doubles its impact on towers with but one inlet face (Fig. 2). Bear in mind that the curve does not predict a constant amount of recirculation, but identifies the nominal amount that would be anticipated under conditions of adverse wind direction.

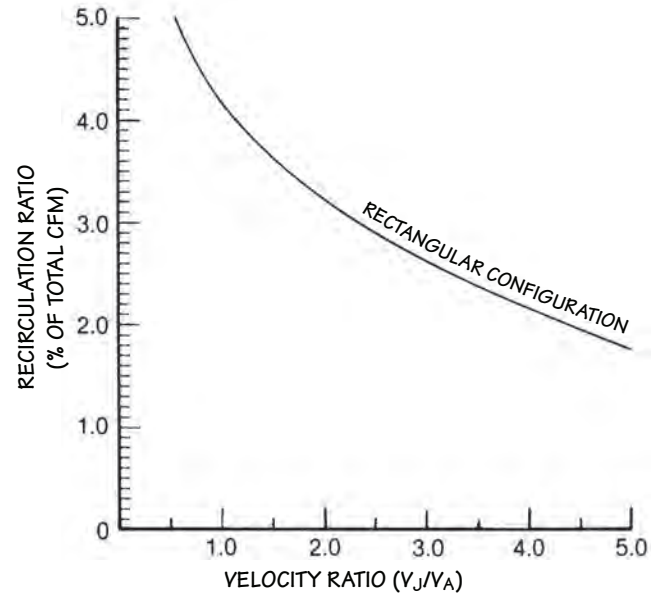

Figure 4—Potential for Recirculation in Rectangular Towers

Recirculation ratios are applied in the following formula to determine the anticipated entering wet-bulb for any given operating condition:

$$h_e = \frac{2 \times \% \text{ Recirc.} \times L \times R}{(100 - \% \text{ Recirc.}) \times G \times n} + h_a$$

- Where
- $h_a$  = Enthalpy of ambient air. (Btu/lb)
  - $h_e$  = Enthalpy of air entering the tower (net). (Btu/lb)
  - $L$  = Mass water rate. (Lb/min) (=gpm x 8.33)
  - $G$  = Mass air rate. (lb/min)(= cfm/specific volume)
  - $R$  = "Range"= Difference between hot & cold water temperatures. (°F)
  - $n$  = Number of principal tower faces equipped with air inlets. (= 1 for single-flow towers, and 2 for double-flow towers)

(Entering wet-bulb temperatures are worked out in the appendix for both induced draft and forced draft towers operating at given conditions.)

The process of recirculation is depicted in Figure 5 for a low velocity discharge, single air entry tower operating in a wind velocity similar to that utilized for Figure 3. At a velocity ratio less than 0.5, its recirculation ratio (double that shown on the Figure 4 curve) would be approximately 10 percent. On the other hand, the induced draft tower would have a velocity ratio exceeding 1.0, resulting in a recirculation ratio of approximately 4 percent. These values would be typical of a tower situated in an open environment, but poorly oriented with respect to the prevailing wind.

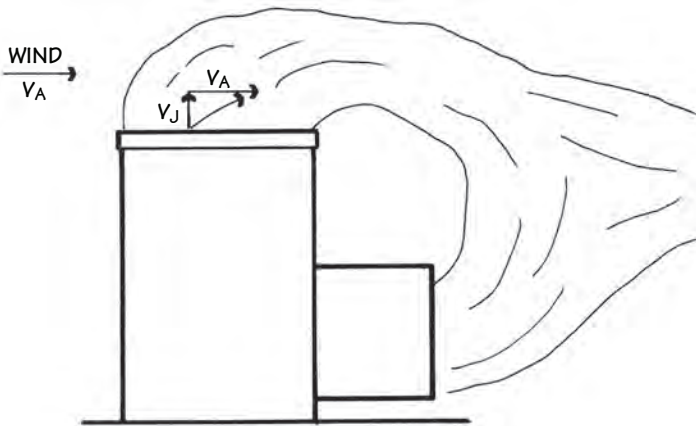

Figure 5—Recirculation

### Interference

Localized heat sources situated upwind of a cooling tower can “interfere” with its expected thermal performance. These interferences may be exhausts from various building systems or processes. Many times, they consist of thermal contribution from the effluent of other cooling towers in the vicinity.

Interference, like recirculation, tends to elevate a cooling tower’s entering wet-bulb temperature, but its effect tends to be somewhat more pervasive. This is because interference can exist without recirculation, and it affects all of the air inlets of a cooling tower equally. Despite the most sophisticated design efforts to reduce recirculation, many cooling towers will experience higher-than-expected wetbulb temperatures purely due to interference. Fortunately, the effect of interference on cold water temperature can often be nullified by preplanning, as will be seen in the “Recommendations” section of this paper.

### Walls or Enclosures

In the broad sense, air restrictions are a form of interference since they interfere with the free flow of air into the cooling tower. To the degree that they redefine the source of incoming air—or increase its velocity—air restrictions also tend to intensify recirculation. Which of the two effects is of greatest concern depends upon the type of tower, as will be seen.

Although air restrictions can take the form of walls, structures, even shrubbery, located in close proximity to the air intake of a cooling tower, enclosures utilized to hide the tower from public view are of primary concern and will be the subject of the remainder of this paper. The reader should understand, however, that any “rules of thumb” developed for clearances within an enclosure apply equally to random adjacent structures or installation “pockets”.

Enclosures offering the greatest potential impact on a cooling tower’s thermal performance are those in which the tower is surrounded on all four sides by solid walls, such that the total air supply to the tower enters the enclosure in a downward direction. Figures 6 and 7 depict such enclosures as they might be applied to induced draft and forced draft towers respectively. Recommended clearance dimensions shown between walls and the tower’s air inlet(s) are those required for towers of one or two cells only. (For purposes of this paper, the number of cells is considered to be equal to the number of fan motors with which the tower is equipped.) For towers of more than two cells, the dimension should be increased by 15 percent for each additional cell. Alternative enclosures will be discussed in relationship to these “solid” enclosures.

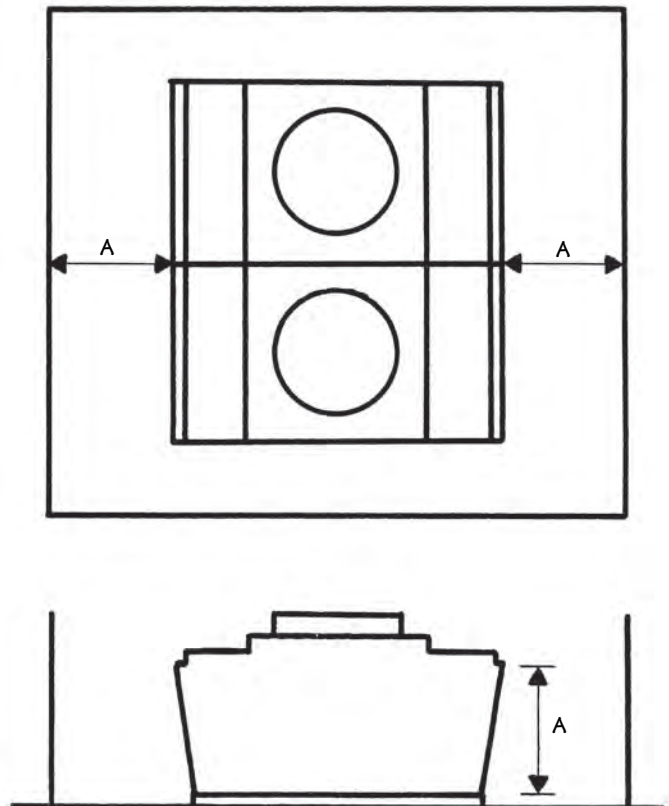

Figure 6—Induced Draft Tower Enclosed by Four Solid Walls

In the induced draft enclosure (Fig 6), the minimum distance required from an air-opposing wall is indicated to be equal to the height of the tower's air inlet (louvered) face. In the forced draft enclosure, however, the required distance is indicated to be equal to twice the tower's width. The reasons for these recommended distances are as follows:

Although induced draft towers tend to be less susceptible to recirculation, they also develop less total static pressure than do forced draft towers and are, therefore, more sensitive to the imposition of external air losses. This means that **enclosures for induced draft towers must be governed by their potential to add system air losses.** In the Figure 6 enclosure, with clearances as shown, the maximum possible downward air velocity will not exceed the lowest velocity component of the tower, the air inlet face. Therefore, since pressure is a direct function of velocity, the added air loss can be considered negligible. Furthermore, although the downward movement of air imposed by the enclosure has effectively relocated the tower's intakes in closer proximity to the exhaust, the 3/1 ratio between discharge and inlet velocities has been maintained, and only slightly greater recirculation potential results.

Conversely, forced draft towers are characterized by relatively high internal static pressures, so the imposition of a small amount of external air loss is of little importance. Were this the primary concern, the clearance distance indicated in Figure 7 would need to be only one tower width. However, because of a forced draft tower's propensity to recirculate, **enclosures for forced draft towers must be governed by their potential to contribute to recirculation.** The clearance indicated in Figure 7 assures an upward discharge velocity at least twice that of the downward velocity into the enclosure. Although a greater out/in velocity differential is desirable in order to diminish the possibility of self-imposed recirculation, further increasing the overall enclosure area usually becomes impractical—and does nothing to improve the discharge plume's velocity relationship to that of the ambient wind. The final step, therefore (not shown in Figure 7), should be to equip the forced draft tower's discharge area with a constricting cowl designed to increase the velocity of the air leaving the tower. Such cowls are available from the manufacturer, and usually require an increase in fan horsepower to overcome the increased static loss. They also necessitate an increase in enclosure height to preclude line-of-site exposure.

Although the obvious purpose of an enclosure is to hide the tower, the height of the enclosure must never exceed the installed height of the tower. That is to say, the elevation of the enclosure walls must be equal to—or less than—the elevation of the tower's point of air discharge. Depressing a tower within an enclosure will increase recirculation tremendously.

Enclosures can also be provided with openings in the walls (either louvered or totally open) to permit some horizontal movement of air into the tower area. In many cases, these openings are designed to compensate for an otherwise inadequate wall distance from the tower's air intakes. However, **the trade-off should never be considered a direct one.** In any opening through which air flows, wall effects and eddy currents always prevent some portion of the apparent net free open area from being an effective flow area. This effective flow area, of course, varies with the design and configuration of the opening. Openings free of obstructions may lose only 5 to 10 percent of the apparent net free area to these effects, whereas walls of perforated building blocks—or busy with louvers—may lose as much as 50 percent. These losses must be compensated for either by limiting wall distance encroachment on the tower, or by appropriately increasing the wall opening's net free area.

Figures 8 and 9 show enclosures in which openings have been provided where possible to “ventilate” the enclosure. In Figure 8, the far end of the enclosure provides ample clearance for that air inlet face of the tower. Although the tower's near air inlet face would appear to be obstructed by a set-back “penthouse” wall, the elevation of the tower within the enclosure affords generous clearance for most of the air inlet face—with the slotted enclosure wall compensating for the remainder.

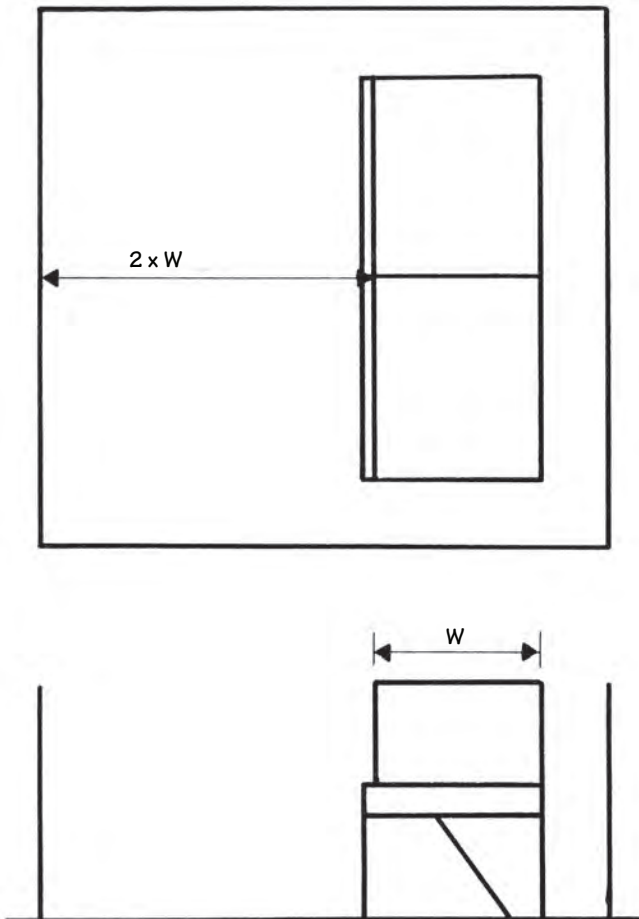

Figure 7—Forced Draft Tower (indented-fan style)  
Enclosed by Four Solid Walls

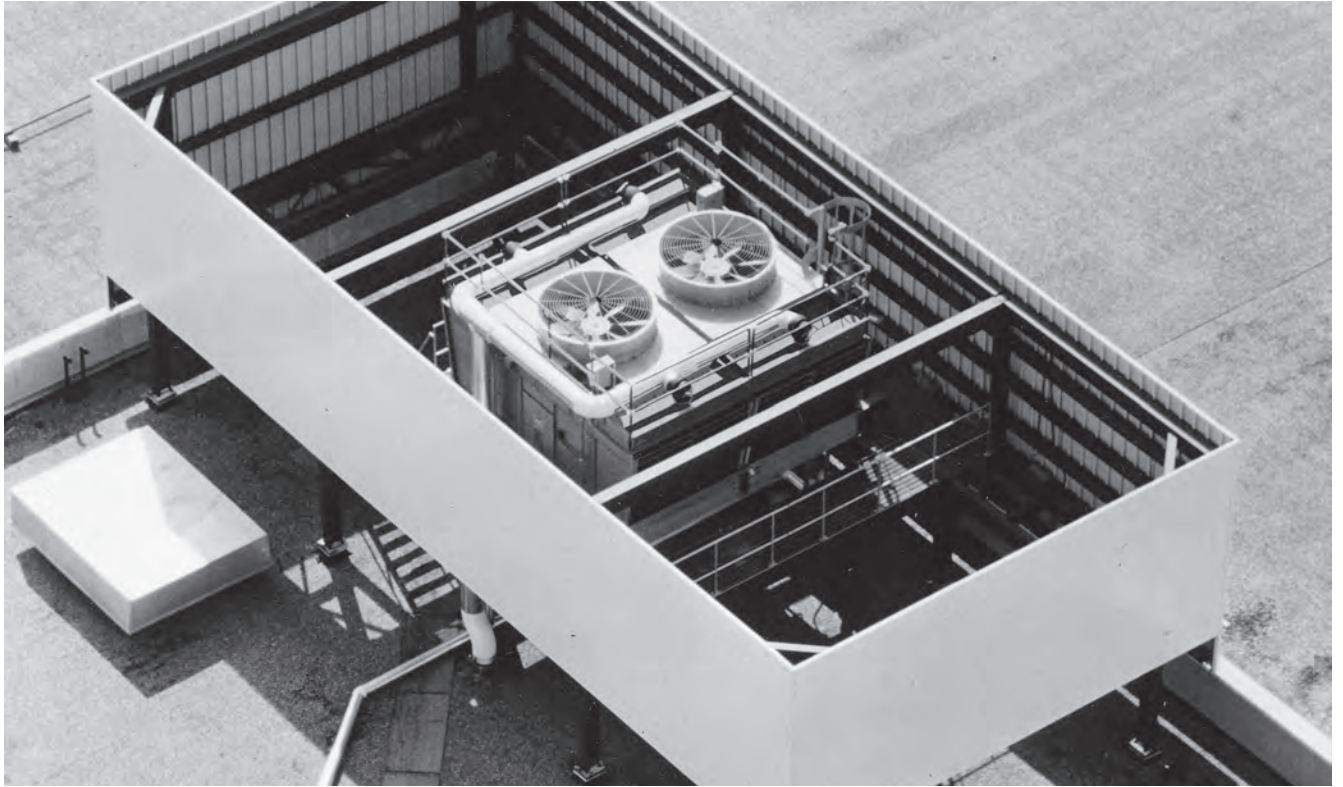

Figure 8

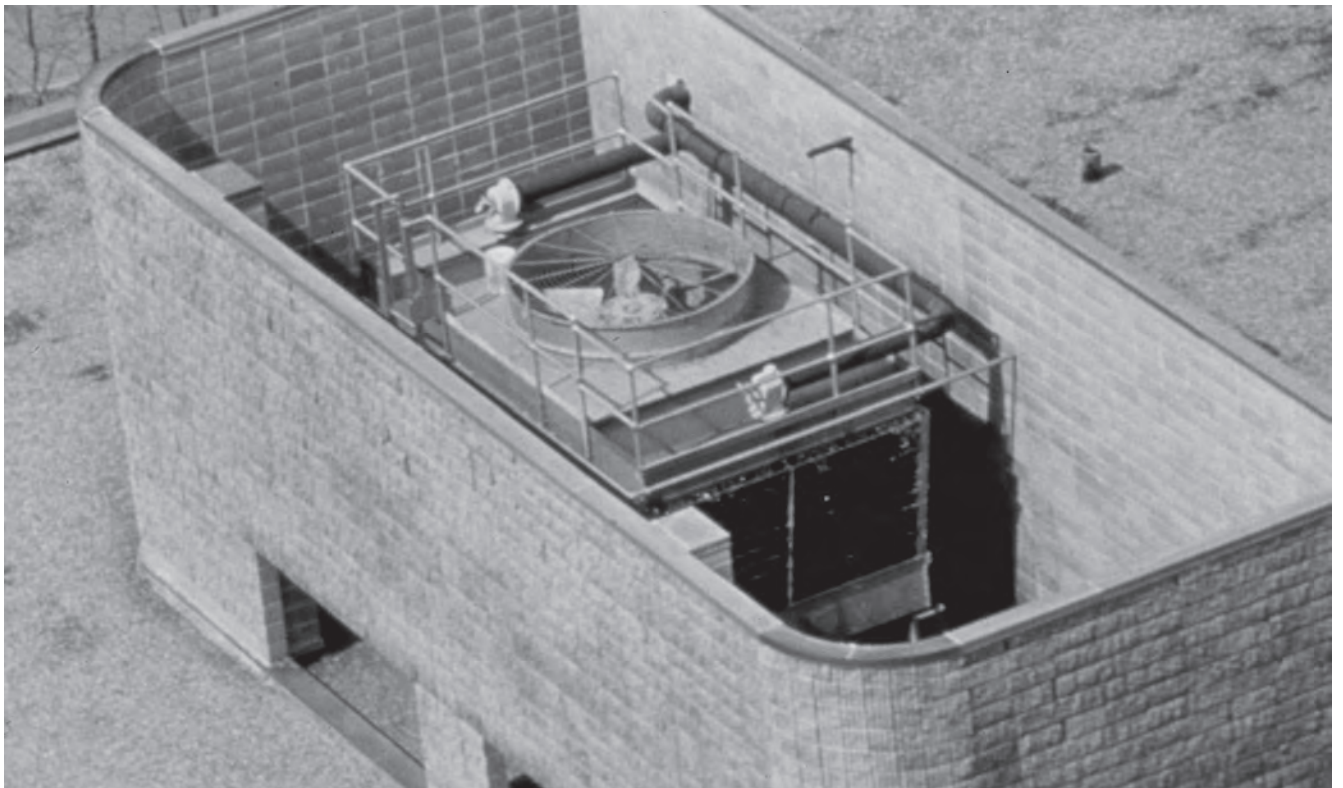

Figure 9

The Figure 9 enclosure is somewhat more restrictive, with compensating air slots having been provided in a side wall. Adequately sized, ventilating slots so located may add but a negligible amount of system static pressure. However, in an adverse wind, they can become an entryway for recirculation. If the prevailing summer wind were from the upper right blowing toward the lower left of the photo, for example, some of the tower's effluent air might have a tendency to be induced into the enclosure's lee-side low pressure zone beyond the enclosure, from which its escape route would be through the slots and into the tower inlets.

**Recommendations**

1. Recommended design wet-bulb temperatures for selected geographical areas are tabulated in various publications, principal among which is "Engineering Weather Data" published by the U.S. Government Printing Office. In many cases, however, these tabulations reflect readings taken at military installations and Class A airports somewhat removed from the "heat island" effect of an urban center. Neither, of course, do they include heat sources within the immediate vicinity of a planned cooling tower site.

Where possible, it is good practice to take wet-bulb temperature readings at the proposed tower site and compare them to simultaneous readings taken at the nearest source of weather data. The difference between these readings will provide justification for adjustment of an apparent design wet-bulb temperature obtained from the most trustworthy publication. Where such measurements would prove awkward

or impossible, it would be recommended that the apparent design wet-bulb temperature be increased by at least 1°F to adjust for an urban area.

2. Unless limited tower siting is available, towers should be situated such that the lee side of the tower (when operating in the prevailing summer wind of highest coincident wet-bulb) is not an air inlet face. This assures that whatever recirculation occurs with seasonal wind shifts will probably occur at some reduced wet-bulb temperature, at which time an elevation in expected cold water temperature might not be considered critical.

3. Where critical recirculation is likely to be unavoidable (as in an enclosure) the design wet-bulb temperature determined in Recommendation No. 1 should be further increased by 1°F for an induced draft tower, or 2°F in the case of a forced draft tower. (See appendix)

4. At the prospect of an unusually "tight" enclosure or adjacent restrictions, conducive to excessive recirculation or static losses, the cooling tower manufacturer should be consulted with regard to a possible change of tower size-or an increase in its operating horsepower.

**Acknowledgment**

With minor changes, this paper was published in the January 1983 issue of **ASHRAE Journal**.

**Appendix**

**Conditions:** Towers selected to cool 2100 gpm from 95°F to 85°F (700 tons) at an ambient air wet-bulb temperature of 78°F. Select Marley Model 8818 NC and BAC Model VXT-700. Towers to operate in a 10 mph wind ( $V_a=880$  ft/min) situated such that an air inlet face is downwind, or towers are located in an enclosure.

**Problem:** Determine anticipated wet-bulb temperature of air entering each tower.

**Solution:**

Item (and source)	Induced Draft	Forced Draft
cfm at Fan (from catalog data) .....	150,889	145,400
cfm at Exit (sp. vol. gains about 2% thru tower) .....	150,889	148,308
G (assume exit sp. vol at 14.5 cu. ft./lb) .....	10,406	10,228
Discharge area (sq. ft.) (from catalog data)		
= fan area of I.D. tower = $\pi \times 5^2$ .....	78.5	
= top plan area of F.D. tower = $24 \times 9.5$ .....		228
$V_j$ (= exit cfm/discharge area) .....	1,922	650
$V_j/V_a$ .....	2.18	0.74
Percent recirculation (from Fig. 4) .....	3.15	4.6
$h_a$ (from psychrometric chart or table) .....	41.58	41.58
L (=2100 gpm x 8.33) .....	17,500	17,500
R (= 95 - 85) .....	10	10
n (= number of opposing air inlets).....	2	1
$h_e$ (from formula on Page 3) .....	42.13	43.23
Entering wet-bulb temperature (°F) (from psych. table) .....	78.52	79.51

**Recommendation:**

Increase design wet-bulb temperature 1°F for induced draft towers, and 2°F for forced draft towers.

**SPX COOLING TECHNOLOGIES, INC.**

7401 W 129 STREET

OVERLAND PARK, KANSAS USA

P: 913 664 7400

F: 913 664 7439

[spxcooling@spx.com](mailto:spxcooling@spx.com)

[spxcooling.com](http://spxcooling.com)

In the interest of technological progress, all products are subject to design and/or material change without notice

ISSUED 1/2012 **H-004**

COPYRIGHT © 2012 SPX Corporation