

*/ Marley Geareducer<sup>®</sup> Model 1800 and 2000 /*

---

*User Manual 00-1218C*



## / Operation and Service Instructions /

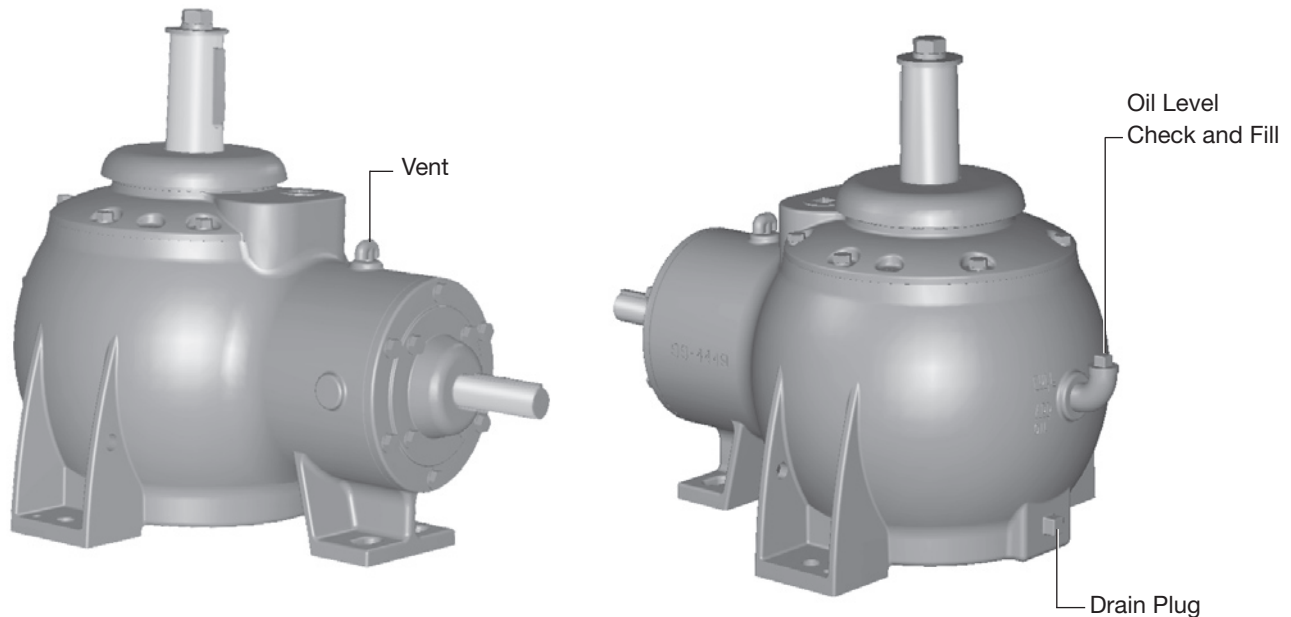

**Figure 1** Service Fittings

### Protection Against Corrosion

Geareducer® units ship from the factory with a protective coating of epoxy enamel paint on all unmachined parts and with rust-proofing oil and grease on machined surfaces. Machined surface coatings normally protect the Geareducer against atmospheric corrosion during storage periods for up to six months. However, if oil is added to the Geareducer, the new oil will dissolve the rust-proofing grease and require that the Geareducer be run once a week to keep a protective coating of oil on all interior machined surfaces.

Check Geareducer exterior yearly and touch up with epoxy paint if required. If your Geareducer is equipped with an oil gauge and drain line, coat any exposed threads at pipe joints to prevent corrosion.

### Alignment

In order to assure long service life, the Geareducer and motor must be level, and the drive shaft or coupling must be properly aligned. Refer to the alignment instructions in the Driveshaft or Coupling Manual shipped with the cooling tower. Copies are also available from your local Marley sales representative.

### Initial Operation

Check to be sure that the Geareducer is filled with oil and that there are no visible oil leaks. If equipped with an external dipstick/oil level gauge, be sure the oil full mark corresponds with the full level at the Geareducer.

**Note**—If this tower is equipped with a two-speed motor, allow a time delay of at least 20 seconds when switching from high speed to low speed. Allow a time delay of at least two minutes when changing direction of fan rotation. Failure to provide these delays may significantly reduce equipment service life.



# / Operation and Service Instructions /

## Lubricants

To insure maximum performance and service life, it is recommended Marley factory lubricants be used in all Marley Geareducers. Marley lubricants can be purchased through your local Marley sales representative.

**Note**—Geareducer is designed for 5-year oil change intervals. To maintain five-year change intervals, use only Marley Gearlube. Marley Gearlube must be inspected every six months to ensure the oil has not been contaminated. If turbine-type mineral oil is used the oil must be changed every six months.

If lubricants other than Marley factory lubricants are used, they must not contain any additives (such as detergents or EP additives) which are adversely affected by moisture and could reduce the service life of the Geareducer. The responsibility for use of lubricants other than Marley factory lubricants rests with the customer/owner and the lubricant supplier.

Seasonal temperature changes may require one viscosity of oil for summer operation and another for winter operation. Refer to the tables below for the seasonal selection information.

Winter or Summer	Severe Duty/High Temperature
Air Temperature at Geareducer	
Below 110°F (43°C)	Above 110°F (43°C)
<b>ISO 150</b>	<b>ISO 220</b>

**Table 1** Synthetic oil—5-year oil change interval

Maintenance Service	Monthly	Semi-annually	Seasonal Startup or Annually
<b>Geareducer Drive:</b>			
Inspect and tighten all fasteners including oil plug		<b>x</b>	<b>x</b>
Check for and repair oil leaks	<b>x</b>	<b>x</b>	<b>x</b>
Check oil level	<b>x</b>	<b>R</b>	<b>x</b>
Change oil		<b>R</b>	<b>R</b>
Make sure vent is open		<b>x</b>	<b>x</b>
Check driveshaft or coupling alignment			<b>x</b>
Inspect and tighten driveshaft or coupling fasteners			<b>x</b>
Check driveshaft or coupling bushing / flex elements for unusual wear			<b>x</b>
<b>Lube Lines (if equipped)</b>			
Check for oil leaks in hoses and fittings	<b>x</b>	<b>R</b>	<b>x</b>

**R** – Refer to instructions within this manual

Note: It is recommended at least weekly, that the general operation and condition be observed. Pay particular attention to any changes in sound or vibration that may signify a need for closer inspection.

# / Operation and Service Instructions /

## Scheduled Maintenance

⚠ **Warning**—Make certain that mechanical equipment is inoperable during periods of maintenance—or during any situation of possible endangerment to personnel. If your electrical system contains a disconnect switch, lock it out until the period of exposure to injury is over.

**Monthly**—Check Geareducer oil level. Shut down the unit and allow 5 minutes for the oil level to stabilize. Add oil if required, noting the addition in your maintenance log. If equipped with an external dipstick/oil level gauge, small quantities of oil can be added at that location.

**Semi-annually**—Check that all the assembly bolts and cap screws are tight, that oil plugs and pipe connections are in place and free from leaks, and that the vent on the Geareducer (and external dipstick/oil level gauge, if present) is clear—a clogged vent can lead to oil leaks. Intermittent operation and extended periods of downtime can cause condensation of water in the oil. If using Marley Gearlube, the oil condition must be inspected every six months—see **Changing Geareducer Oil** for maximizing service life. If using turbine-type mineral oil, change oil—see **Changing Geareducer Oil** for instructions.

**Annually**— Check mechanical equipment anchor bolts, drive shaft coupling bolts, and coupling set screws. Tighten as required.

**Every 5 Years**—Change oil. Geareducer was designed for 5-year oil change intervals. Perform **Monthly** and **Every Six Months** maintenance checks prescribed above. To maintain five-year change intervals, use only Marley Gearlube.

## Changing Geareducer Oil

Drain the Geareducer oil by removing the drain plug. See **Figure 1** for location. If equipped with an external dipstick/oil level gauge, remove the drain plug at that location, and drain the entire system.

To maximize service life of the Geareducer, remove a sample from the drained oil and look for evidence of foreign material, such as water, metal shavings or sludge, or send the oil sample to an oil analysis lab for inspection. If you find unacceptable condensation or sludge, flush the Geareducer with mineral oil before refilling.

After inspection is complete, fill the Geareducer with **9½ quarts** (9 liters) of oil. See **Figure 1** for location. If the Geareducer is equipped with an external dipstick/oil level gauge an additional 2 to 3 quarts (1.9 to 2.8 liters) of oil will be required. Be certain that the vent on the Geareducer (and external dipstick/oil level gauge, if present) is not plugged. Verify that the gauge/drain line is full and that there aren't any leaks at the connections.

## Protection Against Corrosion

Check Geareducer exterior yearly and touch up with epoxy paint if required. If your Geareducer is equipped with an oil gauge and drain line, coat any exposed threads at pipe joints to prevent corrosion.

## Repair and Overhaul

The Model 1800 and 2000 Geareducer is assembled using specialized tools and fixtures. Bearings and gear sets are unique and not available from other sources. Geareducers can be repaired in the field—however, major repairs require the use of a fully equipped machine shop. Refer to the **Field Repair** section of this manual for further instructions.

If your Geareducer ever needs replacement or repair, we recommend returning the unit to a Marley factory service center. Contact your Marley sales representative to discuss course of action. A factory reconditioned Geareducer carries a one year warranty. The Marley cooling tower order number will be required if the Geareducer is shipped back to the factory for repair. Obtain a "**Customer Return Material**" tag from the Marley sales representative in you area.

To find your Marley sales representative call **913 664 7400** or check the internet at **spxcooling.com**

# / Parts List /

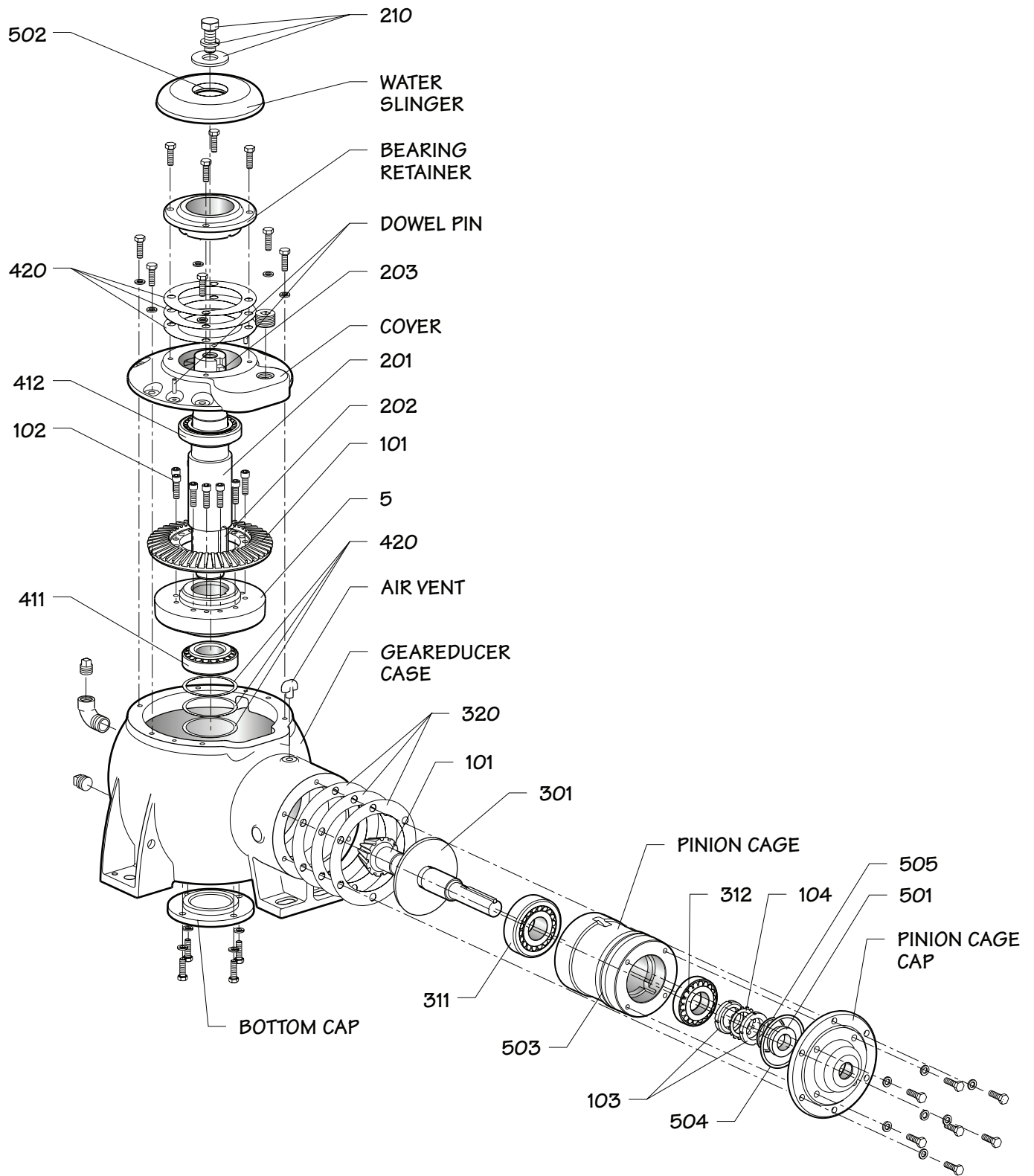

Figure 2

# ***/ Parts List /***

## **Parts List**

- 1** Complete Geareducer Assembly.
- 5** Ring Gear Hub.
- 100** Spiral Bevel Gear Set.
  - 101** Set of matched spiral bevel gears including integral pinion shaft with key.  
Gear ratios as follows:  
4.80 to 1   3.75 to 1   2.71 to 1  
4.09 to 1   3.27 to 1   5.375 to 1
  - 102** Ring gear attaching hardware.
  - 103** Locknuts.
  - 104** Lockwasher.
  
- 200** Fan Shaft Set.
  - 201** Fan shaft.
  - 202** Ring gear hub key.
  - 203** Fan key.
  - 210** Fan attaching hardware.  
Cap screws and washers.
  
- 301** Oil Slinger.
- 310** Set of Two Pinion Shaft Bearings.
  - 311** Head, tapered roller bearing.
  - 312** Tail, tapered roller bearing.
  
- 320** Pinion Cage Shims.
  
- 410** Fan Shaft Bearing Set.
  - 411** Lower tapered roller bearing.
  - 412** Upper tapered roller bearing.
  
- 420** Fan Shaft Shims.
  
- 500** O-Rings Set.
  - 502** Water slinger O-ring.
  - 503** Pinion cage O-ring.
  - 504** Pinion cage cap O-ring.
  - 505** Pinion seal O-ring.
  
- 501** Pinion Shaft Oil Seal.

# / Field Repair /

## General

Geareducers can be repaired in the field—however, major repairs require the use of a fully equipped machine shop. When field repair or replacement of parts is necessary, the following procedure is recommended for the disassembly and assembly of the unit. If any O-ring, oil seal or gasket is to be reused, care should be taken not to damage it during disassembly. Parts which contain O-rings or seals should not be jerked or twisted past a shoulder or edge. These parts are marked with an asterisk (\*) in the description below. O-rings, oil seal and gaskets should be carefully inspected for damage before being reinstalled. New O-rings and oil seal should be installed during a major overhaul.

## Disassembly

Part numbers and references—refer to **Figure 2**.

1. Drain oil.
2. Remove outer ring of bolts in pinion cage cap and remove pinion subassembly\*.

**Note**—The thickness of the shim pack (**320**) is important in resetting the gears. The shim pack should either be saved or carefully measured with a micrometer. If the gears are to be replaced, record the pinion setting distance that is etched on the pinion gear.

3. Remove water slinger\*.
4. Remove bearing retainer and shim pack (**420**) from top of case.

**Note**—The thickness of this shim pack is important in the backlash setting of the gears. The shim pack should either be saved or carefully measured with a micrometer.

5. Drive dowel pins down into case.
6. Remove bolts and case cover and lift fan shaft assembly out of the case.
7. Turn case over and remove bottom cap and shims.

**Note**—The thickness of this shim pack is important in setting the fan shaft bearing endplay. This pack should be saved or carefully measured with a micrometer.

8. Remove bearing cups (**411** and **412**) from the Geareducer case and cover.

## Pinion Cage Disassembly

1. Remove pinion cage cap\* from pinion cage.
2. Remove O-rings\* (**503** and **504**).
3. Slide seal off of pinion shaft and remove O-ring (**505**).
3. Remove locknuts and lockwasher (**103** and **104**) then press pinion shaft (**101**) out of pinion cage. This will free tail bearing cone (**312**).
4. Press oil slinger (**301**) and head bearing cone (**311**) from the pinion shaft.
5. Press bearing cups (**311** and **312**) out of pinion cage.

## Fan Shaft Disassembly

1. Remove ring gear (**101**) from the ring gear hub (**5**).
2. Press ring gear hub and lower bearing cone (**411**) off of the fan shaft (**201**).
3. Remove lower fan shaft key (**202**).
4. Press the top bearing cone (**412**) off of the shaft.

# / Field Repair /

## Assembly

Before assembling a new pinion gear in the pinion cage, check match numbers on pinion gear and spiral bevel ring gear to be certain that they are a matched set. Gears are lapped in matched sets at the factory and should not be separated. Numbers are etched on both the pinion and ring gear as illustrated in **Figure 3**.

All parts that are to be reused should be thoroughly cleaned before being reinstalled. Replace bearings if necessary.

## Pinion Cage Subassembly

1. Place oil slinger (301) on pinion shaft.
2. Press head bearing cone (311) on pinion shaft making sure oil slinger and bearing are against gear.
3. Press bearing cups (311 and 312) into pinion cage.
4. Lower pinion cage on pinion shaft, until head bearing cone and cup mate.
5. Press tail bearing cone (312) on pinion shaft until it mates with its bearing cup.
6. Install locknuts and lockwasher (103 and 104). Tighten nuts on bearing cone until 5 to 15 in-lb<sub>f</sub> (565-1695 mN·m) of bearing preload is obtained. Bearing preload is the resistance in the bearings to shaft rotation measured in in-lb<sub>f</sub> required to rotate the shaft at uniform velocity. Preload is necessary to insure the stability of the gear engagement. Crimp the lockwasher to hold the two nuts in place.
7. Install O-ring (503) in groove on pinion cage. Install O-ring (505) on pinion shaft outboard of locking-nut threads.
8. Install oil seal\* (501) onto the pinion shaft.
9. Position O-ring (504) in groove in cap and place cap on shaft. Slide cap up against pinion cage and install bolts.
10. Record the pinion setting distance that is etched on the pinion gear.

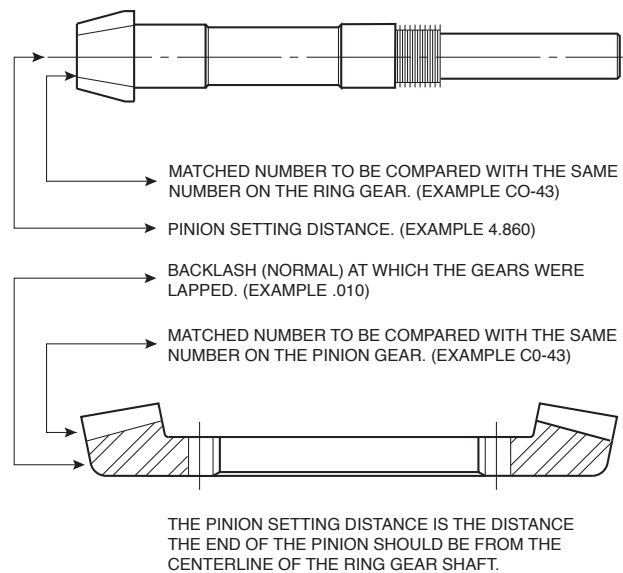

**Figure 3** Gear Match Numbers and Setting Data

# / Field Repair /

## Installation of Fan Shaft

1. Press ring gear hub (5) and the upper and lower bearing cones (411 and 412) on the fan shaft (201). Install ring gear (101) on ring gear hub and tighten cap screws to 55 ft·lb<sub>f</sub> (75 N·m).
2. Install the bottom cap using old shim pack or make up equivalent thickness shim pack (420).
3. Press bottom fan shaft bearing cup (411) in bore.
4. Install fan shaft assembly in case.
5. Press upper fan shaft bearing cup (412) in cover. Apply a bead of sealant to the cover flange inboard of the bolt holes. Install cover on case. Install dowel pins in cover and drive flush with top of cover.
6. Install cap screws and tighten to 20 ft·lb<sub>f</sub> (27 N·m).
7. Install bearing retainer using old shim pack (420) or equivalent and tighten cap screws to 20 ft·lb<sub>f</sub> (27 N·m).
5. Rotate the fan shaft several turns in each direction to seat the bearing rollers. With a dial indicator and using the Geareducer case as a reference, measure and adjust the fan shaft bearings to .001-.003" (.025-.076mm) endplay. The endplay is adjusted by adding shims (420) under the bearing retainer.

## Installation of Pinion Cage

1. Find the difference between the pinion setting distance of the old gear and the new pinion gear and adjust the old shim pack (320) or make a new shim pack to compensate for the different setting distances.

Example:

Pinion setting distance of old gear	4.883
Pinion setting distance of new gear	4.878
Difference	.005

Remove .005 from shim pack.

2. Install pinion cage subassembly into case.

**Note**—Engage pinion gear tooth with "X" marked on end between ring gear teeth marked with "X's". Care must be taken not to damage the pinion gear teeth by forcing them into the ring gear teeth.

## Gear Setting Procedure

The proper mounting of the gear set is essential to obtain long life and smooth operation of the gears. The pinion and ring gears were positioned approximately in the preceding steps. The correct gear position is determined by the gear backlash.

With the "X" marked tooth on the pinion gear engaged between the two "X" marked teeth on the ring gear, check the backlash with a dial indicator as shown in **Figure 5**. Lock the pinion shaft against rotation. The amount of movement of the fan shaft, measured at a distance equal to the outside radius of the ring gear is the backlash. The backlash on all ratios should be between .007 and .014" (.18 and .36mm). With the "X" teeth engaged, the backlash should be approximately in the middle of the allowable range. Check the backlash at three other points around the ring gear to be sure the backlash is within the specified limits. Adjust ring gear axially by removing or adding shims (420) at bottom bearing cap.

**Note**—To maintain bearing adjustment corresponding shim (420) adjustment must be made at the bearing retainer.

**Example:** Removing .003" shims at the bottom bearing retainer requires the addition of .003" shims at the top bearing retainer to maintain correct bearing adjustment.

Recheck the backlash to make sure it is within the proper limits.

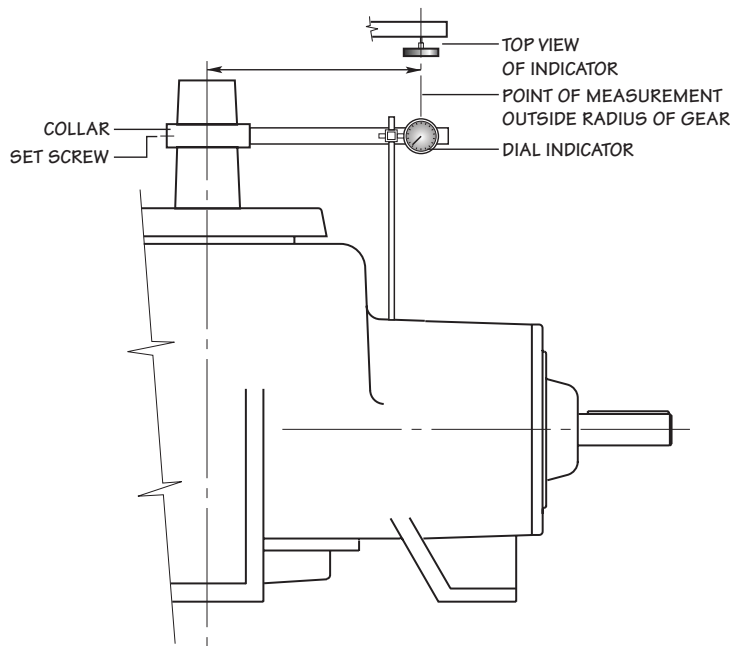

**Figure 5** Gear Backlash Measurement

## ***/ Field Repair /***

### **Final Assembly**

1. Remove bottom cap and apply a bead of sealant to the bottom cap flange inboard of the bolt holes. Reinstall the bottom bearing retainer cap and tighten the cap screws to 20 ft·lb<sub>f</sub> (27 N·m).
2. Install O-ring **(502)** in water slinger.
3. Install water slinger on fan shaft **(201)**.
4. Replace air vent and all pipe plugs.
5. Fill with lubricant selected from **Table I**.

**SPX**<sup>®</sup>

**COOLING TECHNOLOGIES**

7401 WEST 129 STREET | OVERLAND PARK, KANSAS 66213 UNITED STATES | 913 664 7400 | [spxcooling@spx.com](mailto:spxcooling@spx.com) | [spxcooling.com](http://spxcooling.com)

In the interest of technological progress, all products are subject to design and/or material change without notice.  
©2008 SPX Cooling Technologies, Inc. | Printed in USA

**Manual 00-1218C**