

/ Marley Geareducer[®] Model 2700 and 3000 /

User Manual 02-128C

/ Maintenance Schedule /

| Maintenance Service | Monthly | Semi-annually | Seasonal Startup or Annually |
|---|----------|---------------|------------------------------|
| Geareducer Drive: | | | |
| Inspect and tighten all fasteners including oil plug | | x | x |
| Check for and repair oil leaks | x | x | x |
| Check oil level | x | R | x |
| Change oil | | R | R |
| Make sure vent is open | | x | x |
| Check driveshaft or coupling alignment | | | x |
| Inspect and tighten driveshaft or coupling fasteners | | | x |
| Check driveshaft or coupling bushing / flex elements for unusual wear | | | x |
| Lube Lines (if equipped) | | | |
| Check for oil leaks in hoses and fittings | x | R | x |

R – Refer to instructions within this manual

Note: It is recommended at least weekly, that the general operation and condition be observed. Pay particular attention to any changes in sound or vibration that may signify a need for closer inspection.

/ Operation and Service Instructions /

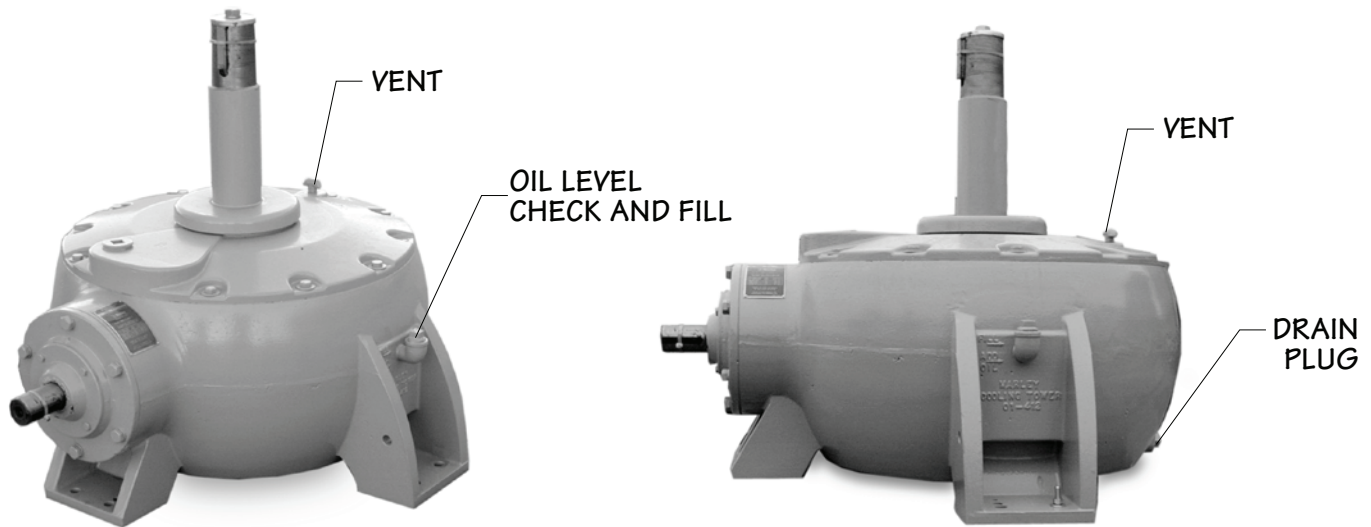

Figure 1 Service Fittings

Initial Protection Against Corrosion

As shipped, a Marley Geareducer[®] is protected internally against corrosion with machine enamel on unmachined parts and with rust-proofing oil and grease on machined surfaces. These coatings normally protect the Geareducer against atmospheric corrosion for storage periods up to six months. However, if oil is added to the Geareducer, it will dissolve the rust-proofing grease and oil, requiring the Geareducer to be operated once a week to keep a protective coating of oil on all interior machined surfaces.

Check Geareducer exterior. If exterior finish has been damaged during shipment or installation, touch up with epoxy paint as required. If Geareducer is equipped with a remote dipstick/oil level gauge and/or drain line, coat any exposed threads at pipe joints to prevent corrosion.

Initial Operation

The Geareducer must be filled with oil to the full oil level mark on the Geareducer case before it is placed in operation. See **Changing Geareducer Oil** section for oil filling instructions.

Geareducers supplied with new towers include oil for the initial filling. Oil is not furnished with Geareducers supplied as spares or on replacement orders. Before operating the mechanical equipment, check to be sure the oil level is at the full mark at the Geareducer and that the external gauge placard (if equipped) full mark corresponds with the “Full” level in the Geareducer. Check any oil lines to be sure there are no leaks.

Be certain that the vent on the Geareducer (and external dipstick/oil level gauge, if present) is not plugged.

In order to assure long service life, the Geareducer and motor must be level, and the drive shaft or coupling must be properly aligned. Refer to the alignment instructions in the Driveshaft or Coupling Manual shipped with the cooling tower. Copies are also available from your local Marley sales representative.

Note—If the tower is equipped with a two-speed motor, allow a time delay of at least 20 seconds when switching from high speed to low speed. Allow a time delay of at least two minutes when changing direction of fan rotation. Failure to provide these delays may significantly reduce equipment service life.



/ Operation and Service Instructions /

Scheduled Maintenance

Warning—Make certain that mechanical equipment is inoperable during periods of maintenance—or during any situation of possible endangerment to personnel. If your electrical system contains a disconnect switch, lock it out until the period of exposure to injury is over.

Monthly—Check Geareducer oil level. Shut down the unit and allow 5 minutes for the oil level to stabilize. Add oil if required, noting the addition in your maintenance log. If equipped with an external dipstick/oil level gauge, small quantities of oil can be added at that location.

Semi-annually—If using turbine-type mineral oil, change oil—see **Changing Geareducer Oil** for instructions. Check that all the assembly bolts and cap screws are tight, that oil plugs and pipe connections are in place and free from leaks, and that the vent on the Geareducer (and external dipstick/oil level gauge, if present) is clear—a clogged vent can lead to oil leaks. Intermittent operation and extended periods of downtime can cause condensation of water in the oil. If using Marley Gearlube, the oil condition must be inspected every six months—see **Changing Geareducer Oil** for maximizing service life.

Annually—Check mechanical equipment anchor bolts, drive shaft coupling bolts, and coupling set screws. Tighten as required. Check Geareducer exterior yearly and touch up with epoxy paint if required. Coat all exposed threads at pipe joints to prevent corrosion.

Every 5 Years—If using Marley synthetic Gearlube, change oil. To maintain five-year change intervals, use only Marley Gearlube. It is recommended to monitor the oil condition every six months throughout the five-year period per the instructions in **Changing Geareducer Oil**.

Lubricants

To insure maximum performance and service life, it is recommended Marley factory lubricants be used in all Marley Geareducers. Marley lubricants can be purchased through your local Marley sales representative.

If lubricants other than Marley factory lubricants are used, they must not contain any additives (such as detergents or EP additives) which are adversely affected by moisture and could reduce the service life of the Geareducer. The responsibility for use of lubricants other than Marley factory lubricants rests with the customer/owner and the lubricant supplier.

Seasonal temperature changes may require one viscosity of oil for summer operation and another for winter operation. Refer to the tables below for the seasonal selection information.

| Winter or Summer | Severe Duty/High Temperature |
|-------------------------------|------------------------------|
| Air Temperature at Geareducer | |
| Below 110°F (43°C) | Above 110°F (43°C) |
| ISO 150 | ISO 220 |

Table 1 Oil viscosity

/ Operation and Service Instructions /

Changing Geareducer Oil

Drain the Geareducer oil by removing the drain plug. See **Figure 1** for location. If equipped with an external dipstick/oil level gauge, remove the drain plug at that location, and drain the entire system.

To maximize service life of the Geareducer, remove a sample from the drained oil and look for evidence of foreign material, such as water, metal shavings or sludge, or send the oil sample to an oil analysis lab for inspection. If you find unacceptable condensation or sludge, flush the Geareducer with mineral oil before refilling.

After inspection is complete, fill the Geareducer with **14 gallons** (53 liters) of oil. See Figure 1 for location. If the Geareducer is equipped with an external dipstick/oil level gauge an additional 3 to 4 quarts of oil will be required. Be certain that the vent on the Geareducer (and external dipstick/oil level gauge, if present) is not plugged. Verify that the gauge/drain line is full and that there aren't any leaks at the connections.

Alternate procedure:

If the cooling tower has an external oil gauge and drain line equipped with a three-way valve below the oil level gauge. See **Figure 2**.

1. Remove pipe plug. Turn valve control stem clockwise to open drain.
2. With Geareducer drained, the three-way valve turned clockwise, and the pipe plug removed, connect fill source

(usually a hose to a pump, to the three-way valve).

Pump oil through the hose. Check oil level occasionally by turning the valve control stem counterclockwise and allowing the oil level in the sight glass to stabilize. Continue filling until full level mark is reached.

3. With the oil level at the full mark turn the valve control stem counterclockwise to close the drain and open the valve to the sight glass. Remove the oil filling line and reinstall pipe plug in the three-way valve.

Repair and Overhaul

The Model 2700 and 3000 Geareducer is assembled using specialized tools and fixtures. Bearings and gear sets are unique and not available from other sources. Geareducers can be repaired in the field—however, major repairs require the use of a fully equipped machine shop. Refer to the **Field Repair** section of this manual for further instructions.

If your Geareducer ever needs replacement or repair, Marley recommends returning the unit to a Marley factory service center. Contact your Marley sales representative to discuss course of action. A factory reconditioned Geareducer carries a one year warranty. The Marley Order Number on your cooling tower will be required if the Geareducer is shipped back to the factory for repair. Obtain a **“Customer Return Material”** tag from the Marley sales representative in you area.

To find your Marley sales representative call 913 664 7400 or check the internet at spxcooling.com.

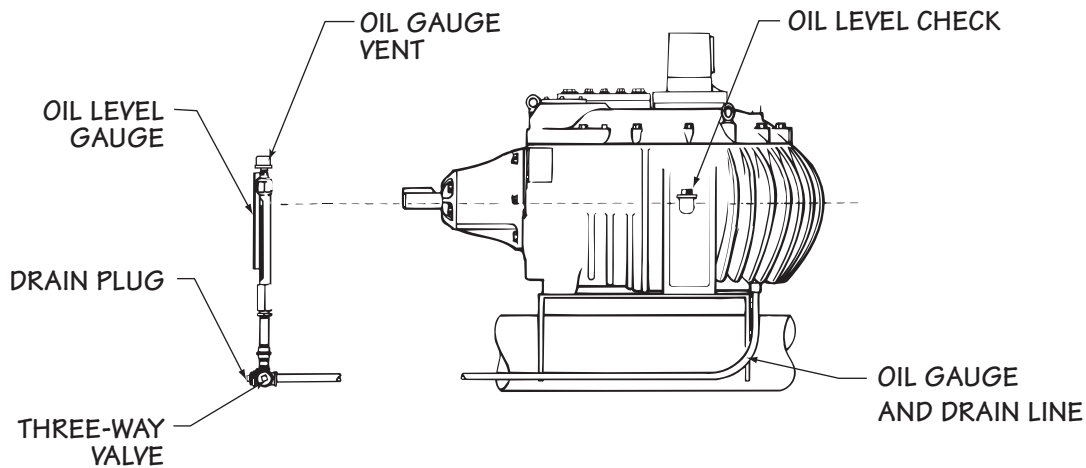

Figure 2 Service Fittings

/ Parts List /

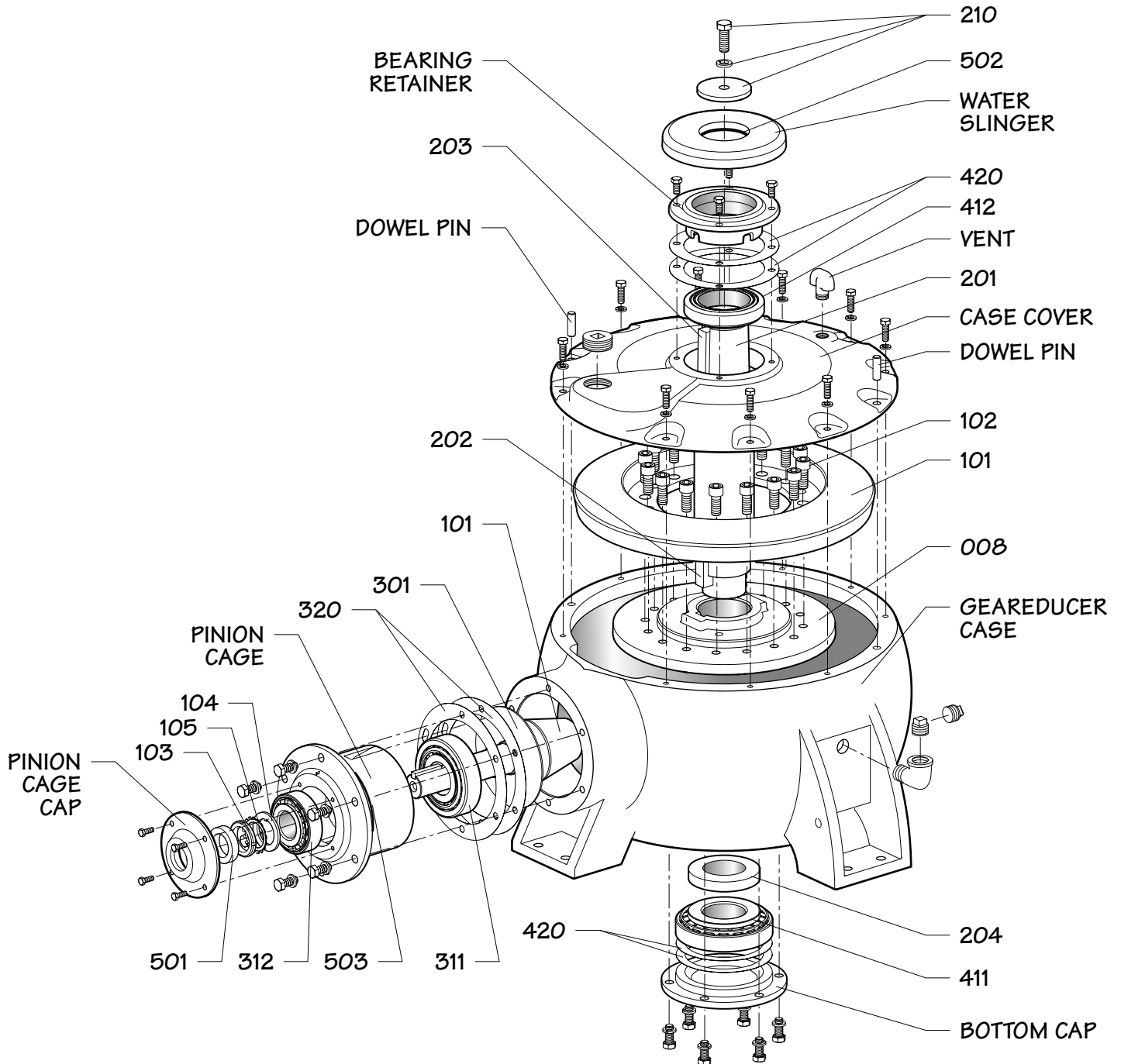

Figure 3

/ Parts List /

Parts List

- 1** Complete Geareducer Assembly
- 008** Ring Gear Hub
- 100** Spiral Bevel Gear Set
 - 101** Set of matched spiral bevel gears, including integral pinion shaft with key
Gear ratios as follows:
 - Model 2700**
5.77 to 1 7.71 to 1 8.66 to 1
 - Model 3000**
5.06 to 1 5.44 to 1 6.14 to 1 6.85 to 1
7.91 to 1 8.80 to 1 9.60 to 1
- 102** Ring gear attaching hardware
- 103** Lock nut
- 104** Tongue Washer
- 105** Lockwasher

- 200** Fan Shaft Set
 - 201** Fan Shaft
 - 202** Ring gear hub key
 - 203** Fan key
 - 204** Ring spacer—Model 2700 Geareducer only
 - 210** Fan attaching hardware
Cap screws and washers

- 301** Oil Slinger
- 310** Set of Two Pinion Shaft Bearings
 - 311** Head, tapered roller bearing
 - 312** Tail, tapered roller bearing
- 320** Pinion Cage Shims

- 410** Fan Shaft Bearing Set
 - 411** Lower tapered roller bearing
 - 412** Upper tapered roller bearing
- 420** Fan Shaft Shims

- 500** O-Ring Set
 - 502** Water slinger O-ring
 - 503** Pinion cage O-ring
- 501** Pinion Shaft Oil Seal

/ Field Repair /

General

Geareducers can be repaired in the field—however, major repairs require the use of a fully equipped machine shop. When field repair or replacement of parts is necessary, the following procedure is recommended for the disassembly and assembly of the unit. If any O-ring, oil seal or gasket is to be reused, care should be taken not to damage it during disassembly. Parts which contain O-rings or seals should not be jerked or twisted past a shoulder or edge. These parts are marked with an asterisk (*) in the description below. O-rings, oil seal and gaskets should be carefully inspected for damage before being reinstalled. Marley recommends that new O-rings and oil seal be installed during a major overhaul.

Disassembly

Part numbers and references—refer to Figure 3.

1. Drain oil.
2. Remove outer ring of bolts in pinion cage and remove pinion subassembly*.

Note—The thickness of the shim pack (320) is important in resetting the gears. The shim pack should either be saved or carefully measured with a micrometer. If the gears are to be replaced, record the pinion setting distance that is etched on the pinion gear. See **Figure 4**.

3. Remove water slinger*.
4. Remove bearing retainer and shim pack (420) from top of case.

Note—The thickness of this shim pack is important in the endplay and backlash setting of the gears. The shim pack should either be saved or carefully measured with a micrometer.

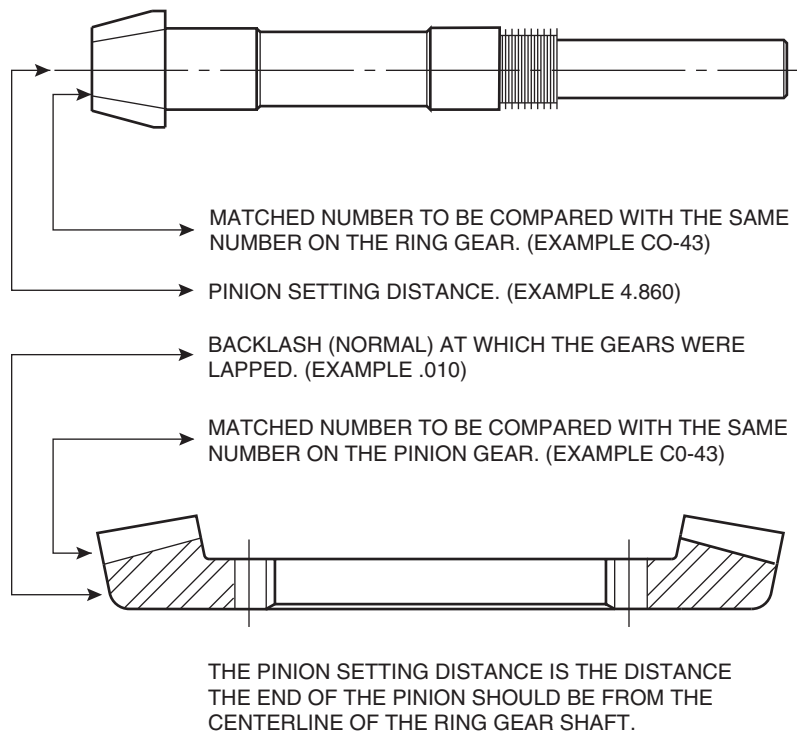

Figure 4 Gear Match Numbers and Setting Data

/ Field Repair /

5. Drive dowel pins down into case.
6. Remove bolts and case cover and lift fan shaft assembly out of the case.
7. Turn case over and remove bottom cap and shim pack (420).

Note—The thickness of this shim pack is important in setting the fan shaft bearing endplay and backlash. This pack should be saved or carefully measured with a micrometer.

8. Remove bearing cups (411 and 412) from the Geareducer case and cover.

Pinion Cage Disassembly

1. Remove pinion cage cap* from pinion cage.
2. Remove O-ring* (503).
3. Remove locknut, lockwasher and tongue washer (103, 105 and 104) then press pinion shaft (101) out of pinion cage. This will free tail bearing cone (312).
4. Press oil slinger (301) and head bearing cone (311) from the pinion shaft.
5. Press bearing cups (311 and 312) out of pinion cage.

Fan Shaft Disassembly

1. Remove ring gear (101) from the ring gear hub (008).
2. Press ring gear hub, ring spacer (204—Model 2700 only) and lower bearing cone (411) off of the fan shaft (201).
3. Remove lower fan shaft key (202).
4. Press the top bearing cone (412) off of the shaft.

Assembly

Before assembling a new pinion gear in the pinion cage, check match numbers on pinion gear and spiral bevel ring gear to be certain that they are a matched set. Gears are lapped in matched sets at the factory and should not be separated. Numbers are etched on both the pinion and ring gear as illustrated in **Figure 4**.

All parts that are to be reused should be thoroughly cleaned before being reinstalled. Replace bearings if necessary.

Pinion Cage Subassembly

1. Place oil slinger (301) on pinion shaft.
2. Press head bearing cone (311) on pinion shaft making sure oil slinger and bearing are against gear.
3. Press bearing cups (311 and 312) into pinion cage.
4. Lower pinion cage on pinion shaft, until head bearing cone and cup mate.
5. Press tail bearing cone (312) on pinion shaft until it mates with its bearing cup.
6. Install locknut, lockwasher and tongue washer (103, 105 and 104). Tighten nuts on bearing cone until 8 to 12 in·lbf (904-1356 mN·m) of bearing preload is obtained. Bearing preload is the resistance in the bearings to shaft rotation measured in in·lbf required to rotate the shaft at uniform velocity. Preload is necessary to insure the stability of the gear engagement. Bend tab(s) on lockwasher to secure locknut in place.
7. Install O-ring (503) in groove on pinion cage.
8. Press oil seal onto pinion shaft.
9. Tighten pinion cage cap screws to 45 ft·lbf (61 N·m).
10. Record the pinion setting distance that is etched on the pinion gear. See **Figure 4**.

Installation of Fan Shaft

1. Press ring gear hub (008), ring spacer (204—Model 2700 only) and the upper and lower bearing cones (411 and 412) on the fan shaft (201). Install ring gear (101) on ring gear hub and tighten cap screws to 75 ft·lbf (102 N·m) for Model 2700 or 150 ft·lbf (203 N·m) for Model 3000.
2. Install the bottom cap using old shim pack or make up equivalent thickness shim pack (420).
3. Press lower fan shaft bearing cup (411) in bore.
4. Install fan shaft assembly in case.
5. Press upper fan shaft bearing cup (412) in cover. Apply a bead of sealant to the cover flange inboard of the bolt holes. Install cover on case. Install dowel pins in cover and drive flush with top of cover.
6. Install cap screws and tighten to 45 ft·lbf (61 N·m).
7. Install bearing retainer using old shim pack (420) or equivalent thickness and tighten cap screws to 45 ft·lbf (61 N·m).



/ Field Repair /

- Measure fan shaft end play with a dial indicator on a surface normal to the plane of rotation. Lift shaft axially and rotate slowly until all axial movement stops. Zero the dial indicator. Lower shaft (zero lifting load) and rotate shaft until axial movement stops. End play will be read directly from the dial indicator. Adjust the fan shaft bearings to .003-.005 (.076-.127mm) end play. The end play is adjusted by adding or removing shims (420) under the bearing retainer.

Installation of Pinion Cage

- Find the difference between the pinion setting distance of the old gear and the new pinion gear and adjust the old shim pack (320) or make a new shim pack to compensate for the different setting distances.

Example:

| | |
|-------------------------------------|-------------|
| Pinion setting distance of old gear | 6.505 |
| Pinion setting distance of new gear | 6.500 |
| <i>Difference</i> | <i>.005</i> |

Remove .005 from shim pack.

- Install pinion cage subassembly into case and tighten cap screws to 75 ft·lbf (102 N·m).
- Engage pinion gear tooth with “X” marked on end between ring gear teeth marked with “Xs”. Care must be taken not to damage the pinion gear teeth by forcing them into the ring gear teeth.

Gear Setting Procedure

The proper mounting of the gear set is essential to obtain long life and smooth operation of the gears. The pinion and ring gears were positioned approximately in the preceding steps. The correct gear position is determined by the gear backlash.

- Based on the backlash etched on the gear set, find the equivalent backlash setting in **Table 2**, Column 2.
- With the “X” marked tooth on the pinion gear engaged between the two “X” marked teeth on the ring gear, check the backlash with a dial indicator as shown in **Figure 5**. Lock the pinion shaft against rotation. The amount of movement of the fan shaft, measured at a distance equal to the outside radius of the ring gear is the backlash. Obtain backlash setting by adjusting ring gear axially by removing or adding shims (420) at bottom bearing cap.

Note—To maintain the previous fan shaft bearing endplay adjustment, a corresponding shim (420) adjustment must be made at the bearing retainer.

Example: Removing .003” shims at the bottom bearing cap requires the addition of .003” shims at the bearing retainer to maintain correct bearing adjustment.

Recheck the backlash to make sure it is within the proper limits.

- After the equivalent backlash setting has been obtained with the marked teeth in mesh, check the backlash at two other points on the ring gear (points approximately 120° apart). See **Table 2**, Column 3 for tolerances.

Final Assembly

- Remove bottom cap and apply a bead of sealant to the bottom cap flange inboard of the bolt holes. Reinstall the bottom bearing cap and tighten the cap screws to 75 ft·lbf (102 N·m).
- Install O-ring (502) in water slinger.
- Install water slinger on fan shaft (201).
- Replace air vent and all pipe plugs.
- Fill with lubricant selected from **Table 1**.

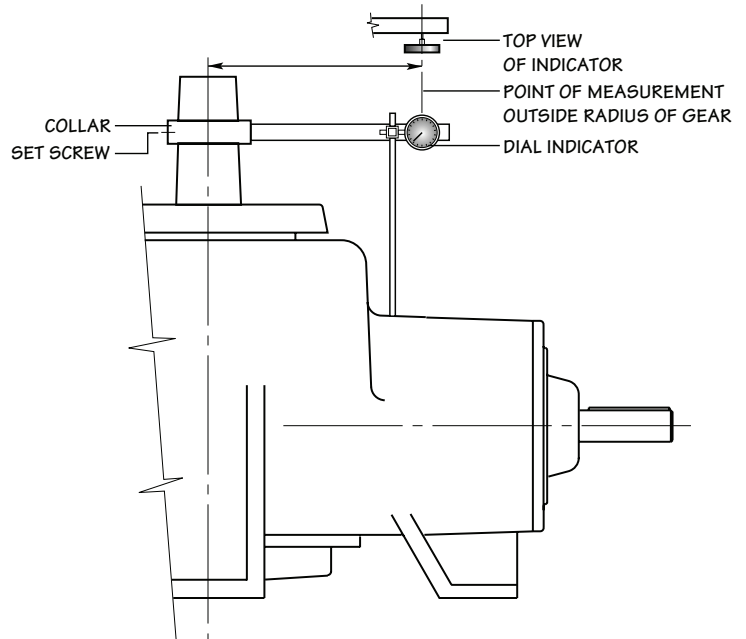

Figure 5 Gear Backlash Measurement

/ Field Repair /

| Backlash Etched on Gears Normal – inches | Set the Gears to Backlash ± .001 Plane of Rotation | Backlash at Check Points may vary from Settings in Column 2 by: ± |
|--|--|---|
| .008 | .010 | .003 / .008 |
| .009 | .0115 | .003 / .008 |
| .010 | .013 | .003 / .008 |
| .011 | .014 | .004 / .010 |
| .012 | .015 | .004 / .010 |
| .013 | .017 | .004 / .010 |
| .014 | .0185 | .004 / .010 |

Table 2

SPX[®]

COOLING TECHNOLOGIES

7401 WEST 129 STREET | OVERLAND PARK, KANSAS 66213 UNITED STATES | 913 664 7400 | spxcooling@spx.com | spxcooling.com

In the interest of technological progress, all products are subject to design and/or material change without notice.
©2008 SPX Cooling Technologies, Inc. | Printed in USA

Manual 02-128C