



MANUAL

AQUACOOLERS



*Installation, Operation
and
Maintenance Instructions*

MODELS

6320	6340	6375
6325	6350	6380
6330	6360	6390

ALWAYS REFER TO TOWER SERIAL NUMBER WHEN WRITING FOR INFORMATION OR ORDERING PARTS FOR THIS AQUACOOLER. SERIAL NUMBER IS STAMPED ON TOWER NAME PLATE LOCATED ON FAN SECTION NEAR MOTOR.

NOVEMBER, 1976

MANUAL 92 - 1318

OM-6320-6390

5800 Foxridge Drive — P.O. Box 2912 — Mission, Kansas 66201

INSTALLATION, OPERATION AND MAINTENANCE — AQUACOOLERS

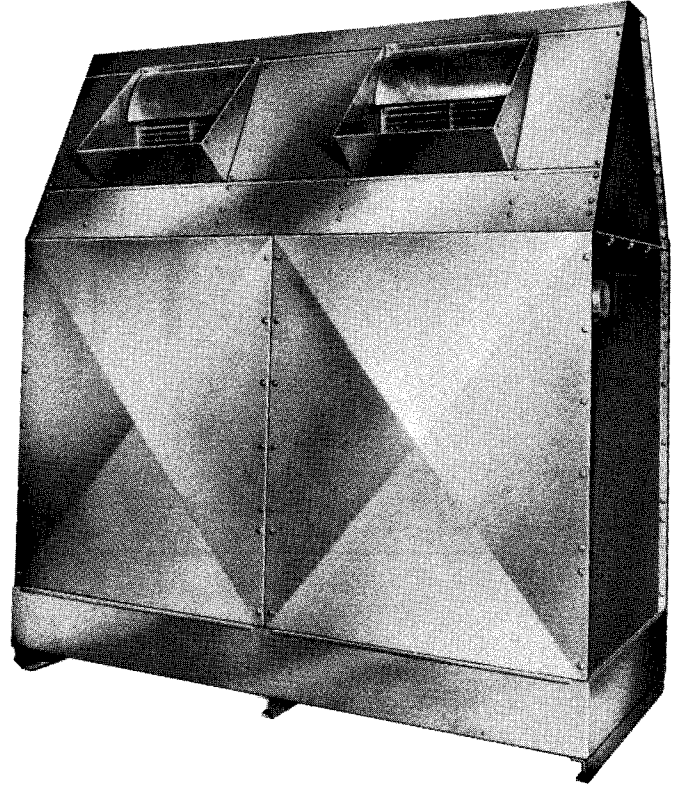
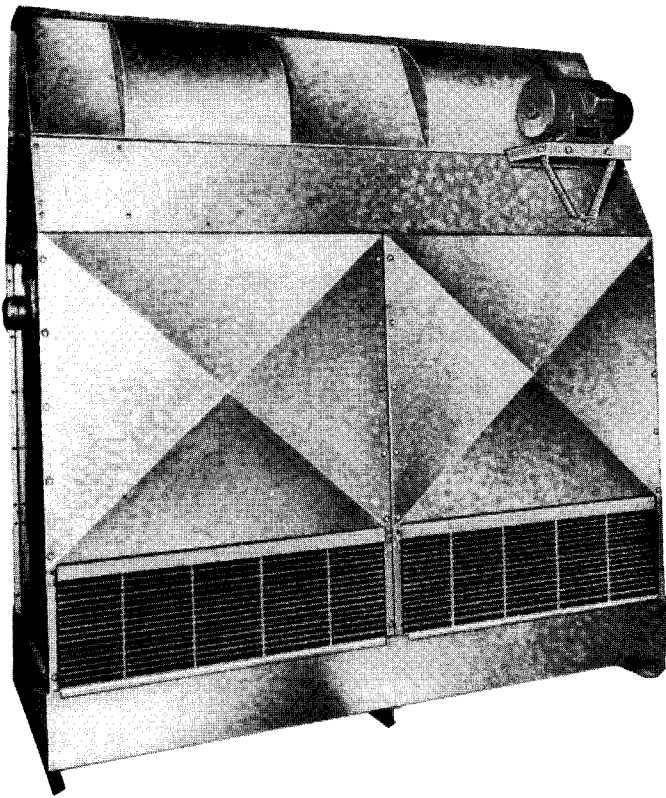

AQUACOOOLER

Installation, Operation and Maintenance Instructions

TOWER PLACEMENT

TOWER LOCATION

Locate tower to obtain the least obstruction to the free flow of air to and from the unit. Allow adequate clearance on all sides of tower for maintenance.

INDOOR INSTALLATION

An indoor installation requires a discharge duct from the fan to the outside of the enclosed space. Ducts impose an additional draft loss that must be overcome by the fan. Care should be taken to insure that this external static pressure does not exceed 0.25 inches of water. Draft losses can be minimized by:

- a. Using 20% oversize ducts.
- b. Avoiding sharp turns, abrupt changes in duct size, and using turning vanes where necessary.
- c. Keeping length of the ducts to a minimum.
- d. Increasing the area of openings covered by screens, grids or louvers so the net free area is at least 20% greater than the fan discharge opening area.

Moisture from condensation inside the duct work may be a problem. The following will help control this:

- a. Insulate the duct work to minimize condensation.
- b. Seal duct work seams so that condensation will not drain outside.
- c. Slope duct work to drain condensation back into tower.

To maintain a low-operating sound level and to prevent transmission of noise through the ducts, the ducts should be connected to the tower with a flexible connection of rubber or canvas and should not be supported by the tower.

OUTDOOR INSTALLATION

Orient tower so the prevailing wind will blow into the air inlets. The fan section should be located with the air discharge opposite to the air inlet side.

POSITIONING AND ANCHORING TOWER

Tower must be installed in a *level position* to operate properly. Preliminary leveling may be done on the tower casing. After piping is completed, the level should be rechecked by placing a level on the top of the honeycomb fill (inside of tower) and placing shims under the tower skids if required.

Tower should be placed on a firm foundation and suitably anchored. Locate anchor clips (to be furnished by customer) at the hoisting holes in the tower skids and attach with 1/2" bolts. Bolt clips to foundation.

TOWER ASSEMBLY AND INSTALLATION

NOTE: Hex head machine bolts are used to attach access panels and may be removed without affecting tower alignment or structural stability. DO NOT remove round head bolts unless absolutely necessary.

GENERAL – The AquaCooler is shipped in three packages. Fill and basin section, fan section and the motor. A hardware and miscellaneous parts carton is shipped in the fan section.

STEP 1 – Remove the protective crating from the fill and basin section. Unbolt and remove shipping skids from the underside of the fan section. *Do not remove shipping blocks from the fan opening at this time.*

STEP 2 – Place fill and basin section in position on foundation.

STEP 3 – Lift fan section and place in position on the fill and basin section. *Remove fan shipping blocks.* Bolt fan section to fill and basin section with hex head bolts, lock washers and nuts.

STEP 4 – Assemble motor support (see Drawing No. 2) and install motor, belt adjusting angle and bolts. Check motor nameplate to be sure voltage, phase and frequency ratings are the same as the power supplied.

STEP 5 – Remove the belt slot access panel. Install the adjustable pitch sheave on the motor shaft. Sheave should be adjusted to the minimum pitch diameter by unscrewing the adjustable half of sheave until the shoulder of the adjustable half is flush with the end of the fixed half. Tighten set screw. Align motor sheave with the fan sheave located in the tower. This can be done with a straight edge across the fan sheave face. Rotate sheaves 1/4 turn and recheck alignment. Tighten set screw on motor sheave.

STEP 6 – Install V-belt and tighten motor adjusting bolts until V-belt is taut. Do not overtighten or the motor bearings may become overloaded. *Recheck belt tension* after tower has been in operation 8 hours.

STEP 7 – Replace belt slot access panel. Install belt slot seal plate and belt guard using sheet metal screws furnished. See Drawing No. 3.

STEP 8 – Connect tower piping. Install bleed-off connection. (See bleed-off table on page 8.) It is recommended that short lengths of rubber hose be used to connect piping to tower to eliminate possibility of transmitting mechanical noise through the piping. If tower is installed outdoors, provide drain plugs in all water lines to prevent freezing during the winter months.

STEP 9 – Install the float valve through the hole in the casing end sheet and secure with the pipe locknut furnished with the float valve. Adjust float ball so valve shuts when

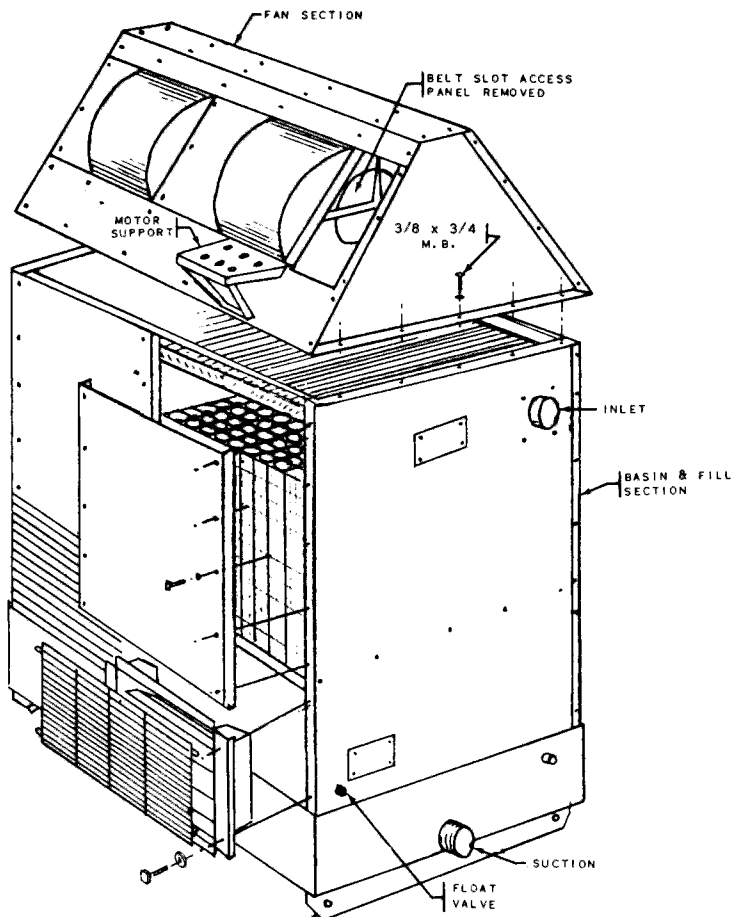

Drawing No. 1 – Tower Assembly

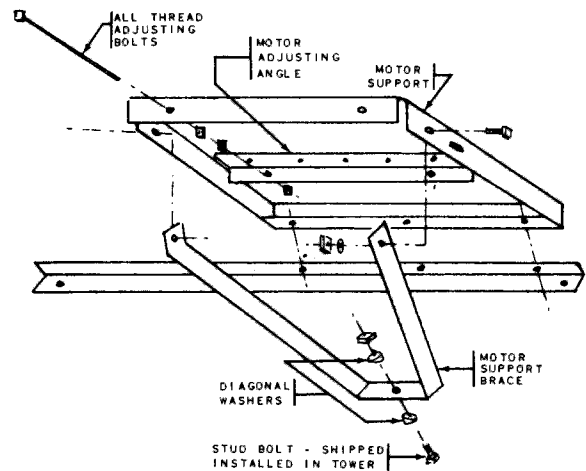

Drawing No. 2 – Motor Base Assembly (Step 4)

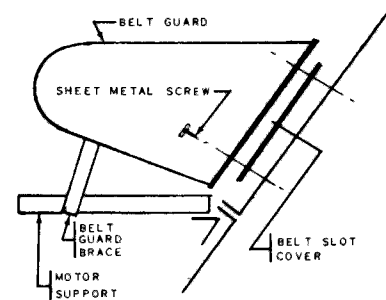

Drawing No. 3 – Belt Guard Assembly (Step 7)

water level reaches 5" in the basin.

STEP 10 – Install drain plug in bottom of basin, or pipe overflow and drain to the sewer.

STEP 11 – Wire motor. All motor wiring switching and overcurrent protection should be in accordance with the National Electrical Code or local requirements. Motor shaft must rotate clockwise when facing the end opposite the shaft extension. Direction of rotation may be reversed by interchanging any two of the three motor leads on a 3-phase motor.

NOTE: Motors above 1 horsepower do not have overload protection. They must be protected by dual element fuses or overload relay heater.

The magnetic starter (not furnished by Marley) usually contains overload relay heaters. Check your starter to see if this protection is incorporated or if you must furnish it separately.

TOWER IS NOW READY FOR START-UP.

START-UP INSTRUCTIONS

1. Check all electrical and piping connections for tightness.
2. Check fan openings to see that all shipping blocks and hardware have been removed.
3. Rotate fan wheel by hand. Check for drag or binding.
4. Wash down the asbestos honeycomb fill and tower basin to remove any accumulated debris. Use low pressure water stream.
5. Install basin drain plug and close all pipe drains.
6. Fill the circulating water system and start the pump. Re-adjust float valve if necessary to maintain 5" of water in the basin when pump is operating. Check spray system to see if all nozzles are operating.
7. Start fan motor. Recheck motor and fan rotation.
8. Check the motor voltage and current. All air inlet and outlet duct work (if used) must be installed and ready for use. *Always* start water circulating through the tower before current readings are taken. With these values, calculate the load horsepower with the following equation:

$$\text{Load Hp} = \frac{\text{Actual Volts} \times \text{Actual Amps}}{\text{Rated Volts} \times \text{Rated Amps}} \times \text{Rated Hp}$$

If the load horsepower determined by the above equation is less than the name plate horsepower, it must be adjusted by increasing the pitch diameter of the motor sheave. Remove the belt guard, loosen the motor adjustment bolts and screw the movable part of the sheave in (1/4 turn at a time). Tighten set screw and motor adjustment bolts and recheck motor load. Continue in this manner until motor is loaded to name plate horsepower. Reinstall belt guard.

9. Check bleed-off to make sure water is being discharged into overflow.
10. TOWER IS NOW READY FOR OPERATION.

MECHANICAL EQUIPMENT

MOTOR. Motor warranty covering manufacturer's material

and workmanship is for one year from date of delivery. Consult the yellow pages of your telephone directory for an authorized motor repair station to make in-warranty repairs.

Motor manufacturers classify cooling tower motors as "Severe Duty Application". Lubricate the motor according to the motor manufacturer's instructions. In general, these instructions are as follows:

1. Grease motor while in operation unless this would create a hazard.
2. Remove grease and relief plugs.
3. Free relief hole of any hardened grease.
4. Add new grease recommended by motor manufacturer until it comes out the relief.
5. Replace fill plug and operate motor approximately 30 minutes with relief open to expel excess grease.
6. Replace relief plug.

Do not mix greases of different type or specification. Flush bearing and housing if change of grease is desired.

FAN BEARINGS. Fill oil cup after 1000 hours operation or every two months (whichever occurs first.) See Bearing Lubrication Instructions on page 9.

V-BELTS AND SHEAVES. If belts slip, adjust belt tension. If necessary, clean belts and sheaves with soapy water. Do not use belt dressing.

FLOAT VALVE. Check periodically for proper operation and maintenance of water level.

TOWER GENERAL. Cold water basin and suction screen should be cleaned as required. Spray system should be inspected frequently for proper operation. Inspection openings are provided.

Fill and eliminators should be inspected once a year and cleaned if required.

DISASSEMBLY PROCEDURE (To Be Used Only If Aqua-Cooler Must Be Moved Through A Small Opening)

IMPORTANT: DO NOT DISASSEMBLE AQUACOOLER MORE THAN IS NECESSARY.

NOTE: As each part is removed, attach the fasteners to that part. Group parts as they are removed for identification.

FAN SECTION

(Refer to Drawing No. 9)

STEP 1 – Remove all hex head machine bolts and lift off access panels.

STEP 2 – Unbolt and remove top cover sheet.

STEP 3 – Unbolt and remove fan end sheets.

STEP 4 – Unbolt and remove motor support angle.

STEP 5 – Unbolt and remove both lower side sheets.

NOTE: On the one-fan towers, further disassembly should not be required. If further disassembly is **ABSOLUTELY** required, proceed as listed for a two-fan tower.

STEP 6 – On two-fan towers, check to see if disassembled section can be moved into place. If not . . .

STEP 7 – Remove fan sheave. This is accomplished by removing the cap screws in the sheave hub and installing them in the open tapped holes in the hub. Tightening the cap screws will then force the sheave off the hub. When the sheave is free, the hub can then be pulled off the shaft.

STEP 8 – Disconnect oil lines from the bearing housings.

STEP 9 – Support fan shaft and remove the self locking nuts used to attach the bearings to their support.

STEP 10 – Loosen the set screws on the fan wheel hub furthest from the sheave end of the shaft and pull fan and housing free of the fan shaft.

CHECK AGAIN TO SEE IF SECTION CAN BE MOVED INTO POSITION. FURTHER DISASSEMBLY REQUIRES REMOVAL OF THE BEARING ASSEMBLIES WHICH SHOULD BE AVOIDED IF AT ALL POSSIBLE.

STEP 11 – Remove protective coating from the fan shaft with kerosene and apply a coat of light oil to the clean shaft.

STEP 12 – Remove the bearing assembly opposite the sheave end of the fan shaft in the following manner:

- a. With an Allen wrench, loosen the set screws in thrust collar and slide the bearing off the shaft.
- b. Put bearing in a safe, clean place where it will not be dropped or mishandled.

LEAVE SECOND BEARING IN PLACE. THERE IS NO REASON TO REMOVE THIS BEARING.

STEP 13 – Loosen set screws on the fan wheel hub and remove fan shaft.

The fan section is now disassembled into its smallest parts. If desired, the fan wheels can be removed from their housings by unbolting the cut-off in the fan discharge openings and rolling the wheel out. The support angle frames can be removed at this time.

FILL AND BASIN SECTION

(Refer to Drawing No. 7)

STEP 1 – Remove the front and back panels, air inlet screen and splash baffle by removing the hex head machine bolts.

STEP 2 – Remove the eliminator section by sliding it out. Store in a safe place to prevent damage to the blades.

STEP 3 – Remove the asbestos honeycomb fill a layer at a time.

STEP 4 – Unbolt and remove the turning vanes located under the fill support.

STEP 5 – Unbolt and remove the top stiffener frame at the top of the tower.

STEP 6 – Unbolt and remove the welded fill support frame.

AT THIS POINT THE TOWER STRUCTURE IS UNSTA-

BLE. USE CARE TO PREVENT DAMAGE TO THE CASING END PANELS.

STEP 7 – On models 6340 thru 6390 towers, remove the U-bolt support located in the middle of the large header pipe.

STEP 8 – Unbolt and remove the spray system assembly. Wire the rubber gaskets to the spray system or the end panels to prevent their becoming lost.

STEP 9 – Unbolt and remove casing panels.

STEP 10 – On models 6340 thru 6390, unbolt the center uprights from the basin gussets only and remove. *Do not disassemble the upright.* No disassembly of the water basin is required.

TOWER IS NOW DISASSEMBLED INTO ITS SMALLEST PARTS AND MAY BE MOVED TO THE REQUIRED LOCATION.

REASSEMBLY PROCEDURE

FILL AND BASIN SECTION

(refer to Drawing No. 4)

STEP 1 – Set cold water basin in position.

STEP 2 – Set the casing end sheets on the basin end support and fasten with round head bolts and lock washers.

STEP 3 – Position spray system. Install rubber gasket between pipe plate and casing end sheet. Bolt assembly in place with bolts and lock washers.

NOTE: Spray system must be level.

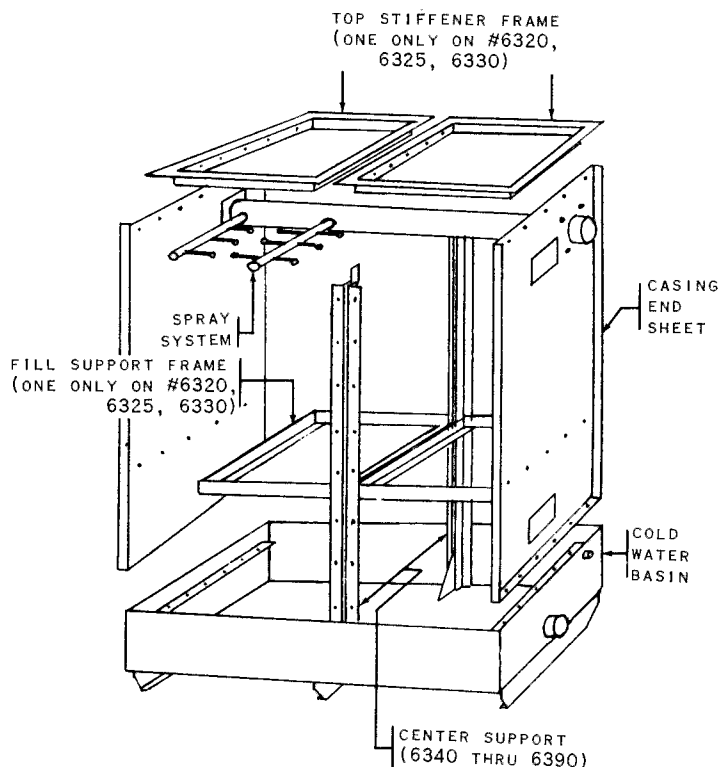

Drawing No. 4 – Casing Assembly (Steps 1 thru 7)

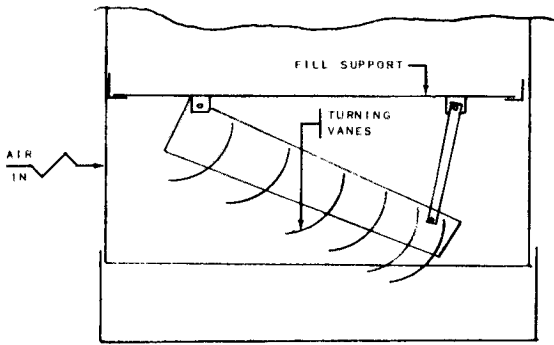

Drawing No. 5 – Turning Vane Installation

STEP 4 – Models 6340 thru 6390 only: Install the center vertical supports. Bolt through basin gusset plates with round head bolts and lock washers.

STEP 5 – Bolt fill support frame(s) to casing end sheets with round head bolts. *Use a rubber backed steel sealing washer under each bolt head.* On models 6340 thru 6390 only, bolt frames to center vertical supports.

STEP 6 – Bolt top stiffener frame in position with round head bolts and lock washers. On models 6340 thru 6390 only, bolt frames to center vertical support.

STEP 7 – On models 6340 thru 6390 only install U-bolt around the header pipe and fasten to the center vertical supports.

STEP 8 – Install turning vanes as shown on Drawing No. 5, using round head bolts and lock washers.

CAUTION: *The bottom edge of curved blades MUST point towards the air inlet.*

STEP 9 – Install fill panels one layer at a time. Do not force or compress panels. Install so length of panels is perpendicular to direction of inlet header.

STEP 10 – Install eliminator section(s).

IMPORTANT: *Eliminators must be installed correctly. Slide eliminator section into position on the support rails*

FILL INSTALLATION
(Refer to Drawing No. 6)

ASBESTOS HONEYCOMB FILL PANELS

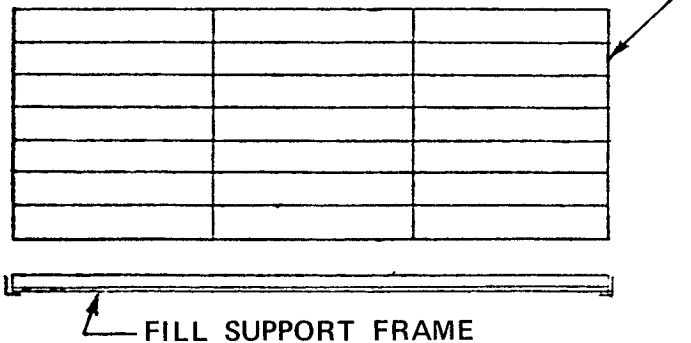

Drawing No. 6 – Fill Installation (Step 9)

above the spray system. When correctly installed the blade tabs will be visible as shown on Drawing No. 7. If blade tabs are not visible, rotate section 90°.

STEP 11 – Inspect the sponge rubber gaskets. Reglue or replace any loose or damaged gaskets.

STEP 12 – Check to see that the “S” strip is on the cold water basin edge. Open groove in strip is inside of basin.

STEP 13 – Install air inlet splash baffles by setting bottom edge of support in the “S” strip groove and swinging assembly into place. Do not bolt in place at this time.

STEP 14 – Line up air inlet screen with holes in splash baffle assembly and bolt both parts to the tower with hex head bolt and rubber backed seal washer.

STEP 15 – Set front and back casing panels in place and fasten with hex head bolts and rubber backed seal washer.

FILL AND BASIN REASSEMBLY IS NOW COMPLETE.

FAN SECTION

(Refer to Drawing No. 9)

NOTE: *Fan section may be assembled on or off the fill and basin section.*

STEP 1 – Bolt angle frames to fan housing with round head bolt, cut washer and lock washer. Roll fan wheel into housing and install fan cut-off sheet.

STEP 2 – Set the lower side sheets in position and bolt to fan housing frames with round head bolts and lock washers.

STEP 3 – Install motor support angle and motor support brace bolt to the fan housing frame as shown on Drawing No. 9 using serial number plate as location reference.

STEP 4 – Bolt top cover sheet to fan housing frames with round head bolts, cut washers and lock washers.

STEP 5 – Fan shaft with attached bearing is to be installed on the serial number plate end of the fan section.

On models 6320, 6325 and 6330: Slide the fan shaft through fan wheel hub until the attached bearing assembly is in line with the holes in the bearing support bar. *(Do not tighten fan hub set screws at this time.)*

On first models 6340, 6350 and 6360: Slide the fan shaft through fan wheel hub until the attached bearing assembly is in line with the holes in the bearing support bar. *Do not assemble to second fan or tighten fan hub set screws at this time.*

STEP 6 – Install second bearing on shaft. Leave set screws loose.

Use extreme care – do not force or hammer on bearing. Keep all parts clean and free from dirt. A light coat of oil on fan shaft will help installation.

STEP 7 – On models 6340, 6350 and 6360: Push fan shaft through second fan wheel hub until end of shaft is flush with end of hub. *Do not tighten fan hub set screws.*

STEP 8 – Align fan shaft and fasten bearings to the support bar with bolts and self locking nuts.

STEP 9 – Tighten bearing thrust collar set screws.

STEP 10 – Adjust fan wheel(s) until there is equal clear-
(continued page 7)

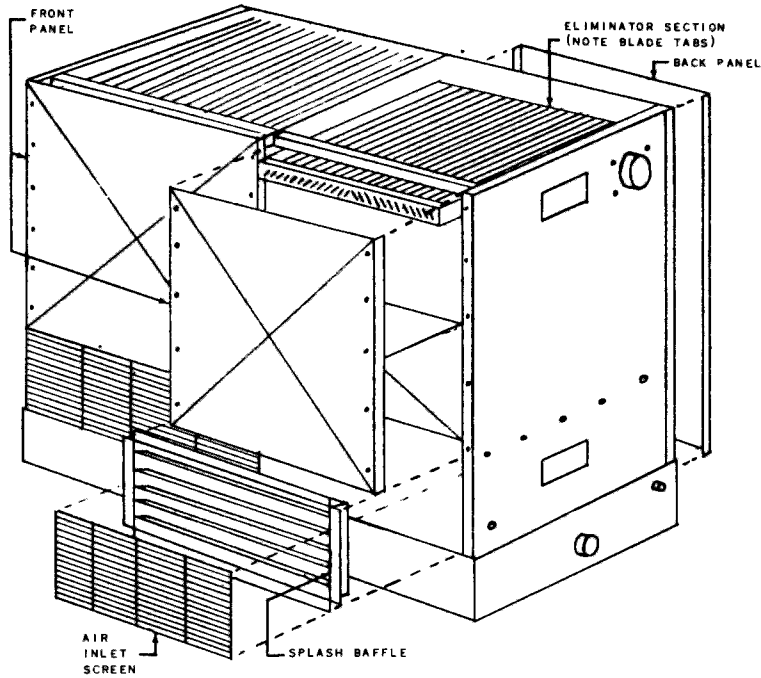

Drawing No. 7 – Fill and Basin Assembly

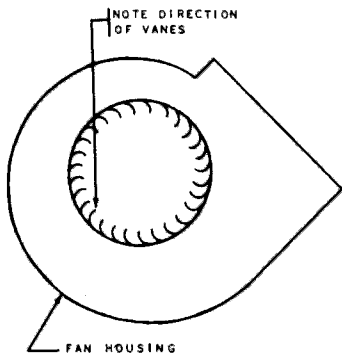

Drawing No. 8

ance on both sides of the fan housing and tighten fan set screws.

STEP 11 – Connect oil lines to the bearing housings. Fill oil cups and oil lines with recommended lubricant. See page 9.

STEP 12 – Install fan sheave as follows:

- a. Place sheave without bushing on the fan shaft and push sheave back against the bearing.
- b. Install bushing on the shaft small end first and push until end of the shaft is flush with flanged end of the bushing.

(continued top page 8)

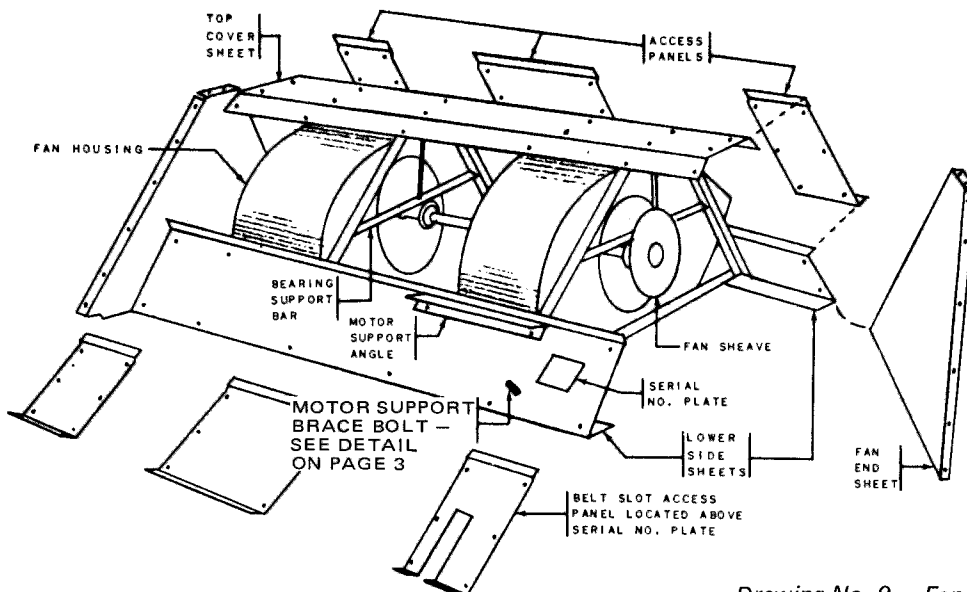

Drawing No. 9 – Fan Section Assembly

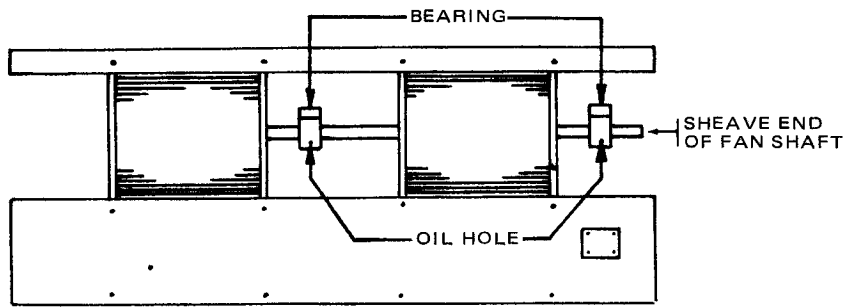

Drawing No. 10 – Fan Shaft Installation (Step 5)

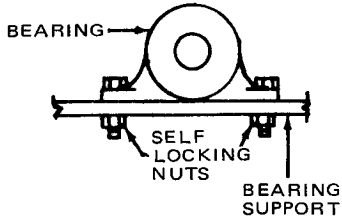

Drawing No. 11 – Bearing Installation

c. Pull sheave on bushing. Install cap screws through the large holes in the bushing flange and into the tapped holes in the sheave and tighten assembly.

STEP 13 – Install fan section end panels and fasten with round head machine bolts, cut washers and lock washers.

STEP 14 – Install access panels and fasten with hex head bolts, cut washers and lock washers.

WATER PROBLEMS AND TREATMENT

BLEED-OFF

Bleed-off is the continuous removal of a small portion of the water from the circulating system. The purpose of bleed-off is to prevent dissolved solids from concentrating to the point where they will form scale. As a guide, many waters can be allowed to concentrate two or three times without causing scale problems. The amount of bleed-off to hold concentrations to two or three depends upon the cooling range (hot water temperature minus cold water temperature). The following table shows amount of bleed-off required at three different cooling ranges.

Cooling Range °F.	% of Circulating Rate to Bleed-Off*	% of Circulating Rate to Bleed-Off**
5	.18	.38
10	.38	.78
15	.58	1.18

*Maintain 3 concentrations; **Maintain 2 concentrations

EXAMPLE: 80 gpm circulating rate, cooling range 10°F. To maintain 3 concentrations, the required bleed-off = 80 x .0038 = .30 gpm.

CHEMICAL TREATMENT

The quality of many municipal waters is such that chemical treatment for scale prevention or removal will not normally be required if adequate bleed-off is maintained. In areas where bleed-off alone is not sufficient to prevent ob-

jectionable scale or corrosion, use a simplified phosphate treatment as directed by the local supplier of water treating materials.

Algae and slime may occur and can be controlled by careful application of proper chemicals. Improper application of concentrated water treating chemicals may damage parts of the system. If scale or algae and slime accumulate, obtain the services of a competent water treating consultant.

FOAMING

Foaming occasionally becomes a problem with certain water conditions when a new tower is put into operation. The condition is not normally persistent for an extended period and foaming can be lessened by increasing bleed-off until the condition is improved. If increased bleed-off does not lessen foaming sufficiently, a foam depressant chemical should be used. These are generally available through local chemical supply companies and some water treating companies.

WATER DISCOLORATION

Discoloration, like foaming, is a condition that develops when a new tower is put into operation. It will not harm the normal components in an open recirculating cooling system. However, if discoloration is objectionable, it can be reduced by increasing bleed-off or the system may be emptied and refilled once or twice after the initial start-up of the tower. Commercial bleaching agents may be used but must be used with care as they may damage the system.

SEASONAL SHUTDOWN INSTRUCTIONS

BASIN AND FRAME

Drain the tower basin and all exposed piping. Leave the basin drain open. Water may be left in basin if tower is located in a non-freezing area.

During shutdown, clean the tower and make any necessary repairs. Apply protective coating as required to all metal parts. Particular attention should be given to bearing supports.

MECHANICAL EQUIPMENT

V-BELTS

At shutdown, inspect V-belts and if worn excessively, replace before start-up.

SLEEVE BEARINGS, Oil Lubricated Type

Check oil level once each month and add oil if necessary. See next section for lubricating oil information. Rotate shaft by hand to assure all parts are coated with oil.

ELECTRIC MOTORS

Do not start motor without determining that there will be no interference with free rotation of the fan drive.

Motors are equipped with grease or oil lubricated bearings. Refer to motor manufacturer's recommendations for lubrication and maintenance instructions.

If shutdown period is longer than seasonal, contact the Marley sales office or representative in your area for additional information.

BEARING LUBRICATION

Fan bearings are lubricated at the factory. Original lubrication is adequate for approximately 1000 hours or two months of normal operation. *It is not necessary to add at more frequent intervals.*

Fan bearings are constructed with an oil reservoir between the spherical outer shell and the bronze sleeve. The reservoir is packed with wool felt which absorbs oil and distributes it through feed plugs in the oil grooves. (See illustration.) Graphite filled grooves redistribute oil to the bearing surface.

Rate of oil flow through the bearings is controlled by density of wool and graphite packing. Variance in packing dens-

ity results in differences in the length of time required for oil cups to empty; time required may vary from a few days to several weeks or months.

If oil flow rate permits the oil cup to empty in one to two days:

1. Check oil line for leakage.
2. If oil line shows no leakage continue *recommended lubrication schedule*. It is not necessary that oil be visible in cup between fillings.

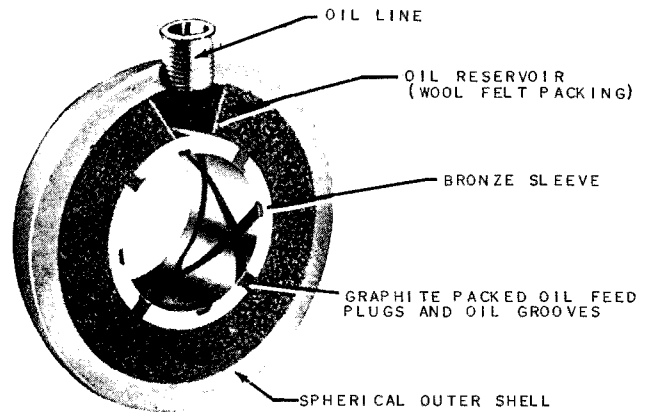

CROSS SECTION THROUGH BEARING

RECOMMENDED LUBRICANTS

Recommended lubricants are industrial type mineral oils or automotive crankcase oils except those designated "Detergent," "Heavy Duty," or "Compounded." For given operating conditions use the following oils:

Summer or Indoor Operation
(40°F. to 110°F.) – SAE 50
Winter, Outdoor Operation
(0°F. to 40°F.) – SAE 10

When the tower is located outdoors and is operated during summer and winter seasons, it is recommended that the change from SAE 50 to SAE 10 oil be made during a period of temperature transition to insure the lighter oil has adequate time to flow from the oil cup to the bearing reservoir. If oil change is made in cold weather, remove and drain oil line before adding SAE 10 oil.

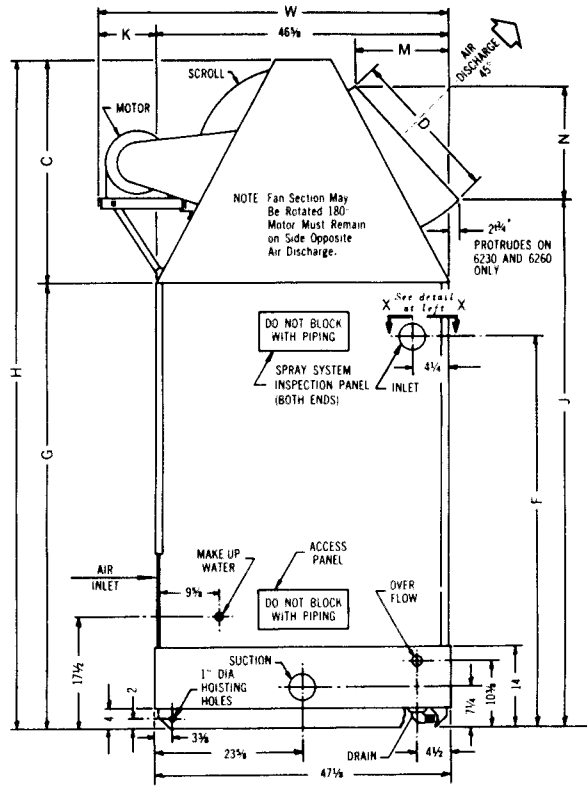
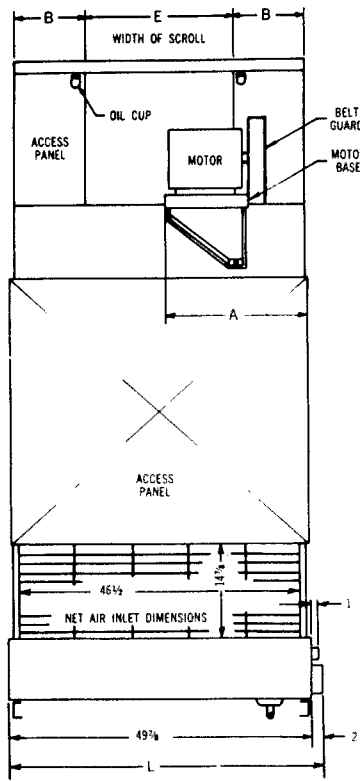
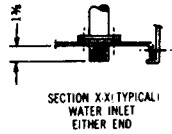

Models 6320,
6325 and 6330

MODEL NO.	DIMENSIONS IN INCHES													CFM	NO. OF FANS	HP. ③	PIPE SIZES, INCHES					WEIGHTS		
	TOWER OVERALL			A	B	C	D	E	F	G	J	K	M				N	INLET	SUCTION	DRAIN	OVERFLOW	FLOAT VALVE	SHIPPING (Less Motor) ④	OPERATING (Wet) ⑤
	W	L	H																					
6320	55 1/4	51 7/8	98	25	14	31 1/4	24 5/8	21	58 1/4	66 3/4	80 3/8	8 5/8	18	17 1/2	5875	1	1 1/2	3m	4m	1 1/2 m	2m	1/2 m	1278	1880
6325	55 1/4	51 7/8	104	25	14	31 1/4	24 5/8	21	64 1/4	72 3/4	86 3/8	8 5/8	18	17 1/2	6380	1	2	3m	4m	1 1/2 m	2m	1/2 m	1358	2030
6330	57	51 7/8	109	23 3/8	12 3/8	36 1/4	28 3/4	24 1/4	64 1/4	72 3/4	88	10 1/2	17 3/8	20 1/8	8110	1	3	3m	4m	1 1/2 m	2m	1/2 m	1424	2175
6340	55 1/4	98 5/8	98	25	14	31 1/4	24 5/8	21	58 1/4	66 3/4	80 3/8	8 5/8	18	17 1/2	11750	2	3	4m	4m	1 1/2 m	2m	1/2 m	2278	3515
6350	55 1/4	98 5/8	104	26	14	31 1/4	24 5/8	21	64 1/4	72 3/4	86 3/8	8 5/8	18	17 1/2	13870	2	5	4m	4m	1 1/2 m	2m	1/2 m	2382	3710
6360	57	98 5/8	109	24 3/8	12 3/8	36 1/4	28 3/4	24 1/4	64 1/4	72 3/4	88	10 1/2	17 3/8	20 1/8	16220	2	5	4m	4m	1 1/2 m	2m	1/2 m	2541	3980

① Wet operating weights are based on 6 inches of water in tower basin. ② Protected motors are furnished on these models.
 ③ Motor weights: Models 6320, 6325—75 lbs., Models 6330, 6340—110 lbs., Models 6350, 6360—122 lbs.,
 Pumping head is 18.0 feet for Models 6320 and 6340 and 18.5 feet for all other models in the table above. Pump head is measured from base of tower when circulating 3 gpm per ton at 95-85-78. For other conditions obtain pump head data from your Marley sales engineer.

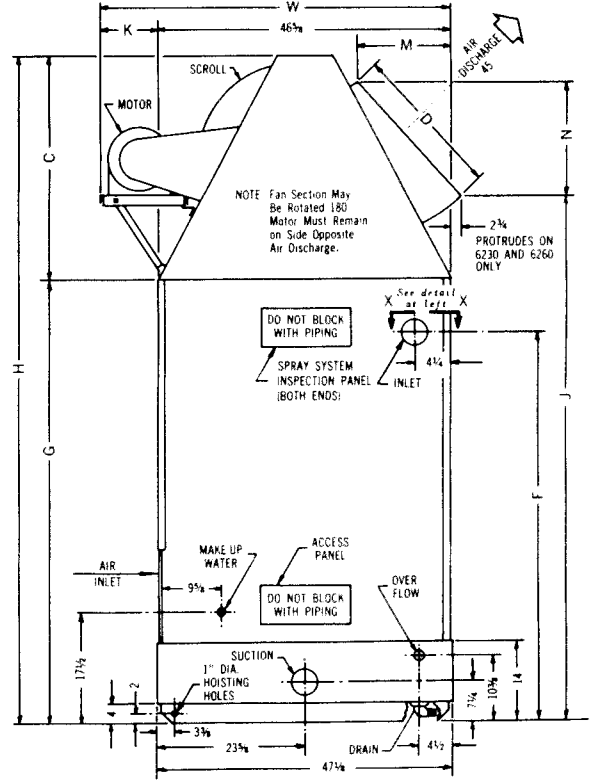
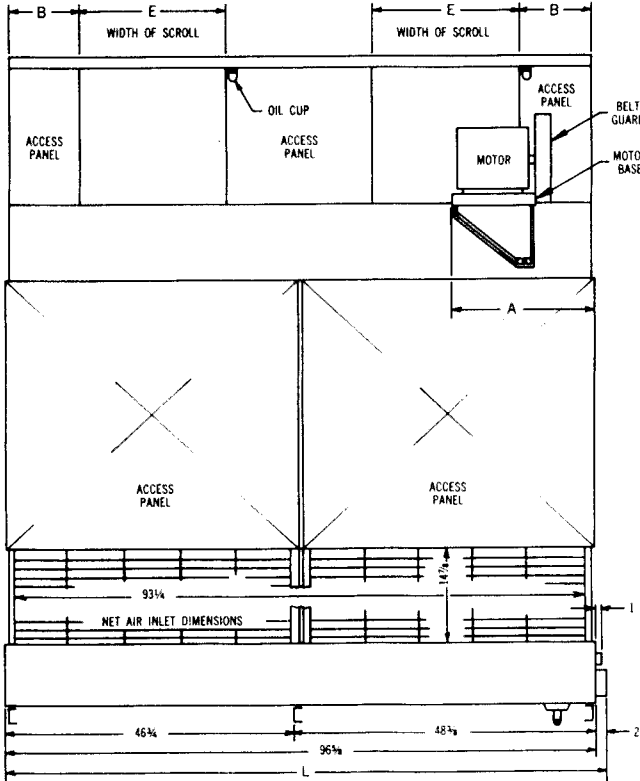
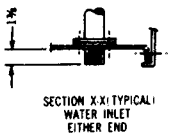

Models 6340,
6350 and 6360

MODELS 6375, 6380, 6390

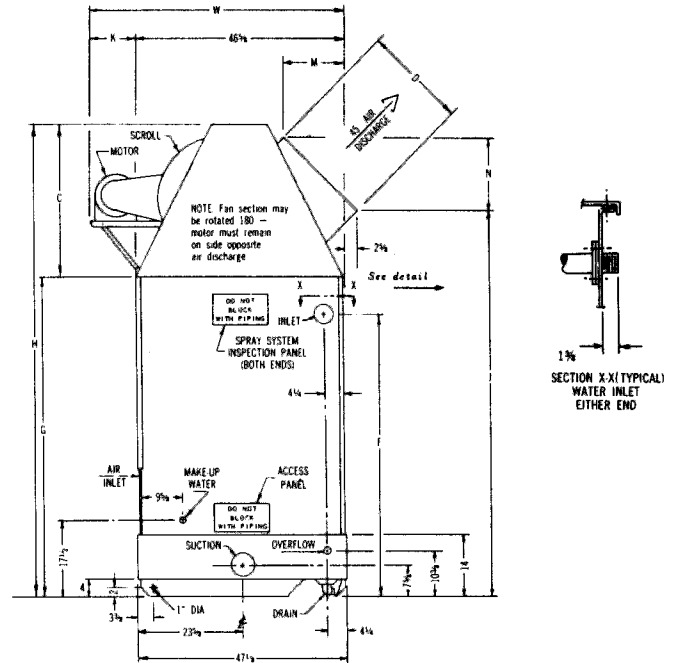
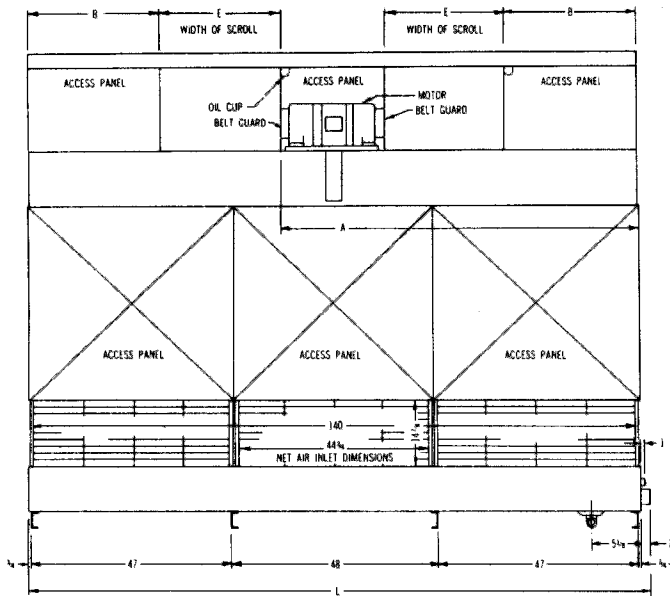

MODEL NO.	DIMENSIONS IN INCHES													CFM	NO. OF FANS	HP. ⑥	PIPE SIZES, INCHES				WEIGHTS			
	TOWER OVERALL			A	B	C	D	E	F	G	J	K	M				N	INLET	SUCTION	DRAIN	OVERFLOW	FLOAT VALVE	*SHIPPING (Less Motor)	OPERATING (Wet) ⑦
	W	L	H																					
6375	57	145 1/2	109	87	24 1/2	36 1/4	28 3/4	24 1/4	64 1/4	72 3/4	88	10 1/2	17 3/8	20 1/8	19640	2	7 1/2	4m	6m	1 1/2 m	3m	3/4 m	3550	6035
6380	57	145 1/2	109	87	24 1/2	36 1/4	28 3/4	24 1/4	64 1/4	72 3/4	88	10 1/2	17 3/8	20 1/8	21540	2	10	4m	6m	1 1/2 m	3m	3/4 m	3555	6060
6390	57	145 1/2	109	87	24 1/2	36 1/4	28 3/4	24 1/4	64 1/4	72 3/4	88	10 1/2	17 3/8	20 1/8	24660	2	15	4m	6m	1 1/2 m	3m	3/4 m	3560	6125

1. Wet operating weights are based on 6 inches of water in tower basin.
2. Protected motors are furnished on these models.
3. Motor weights L Model 6375 – 200 lbs., Model 6380 – 225 lbs., Model 6390 – 290 lbs.

Pumping head is 18.5 feet for all models in table above. Pump head is measured from base of tower when circulating 3 gpm per ton at 95–85–78. For other conditions obtain pump head data from your Marley sales engineer.