

*/ Marley Geareducer<sup>®</sup> Model 2200 and 2400 /*

---

*User Manual 99-1260D*

**SPX**

COOLING TECHNOLOGIES



## / Operation and Service /

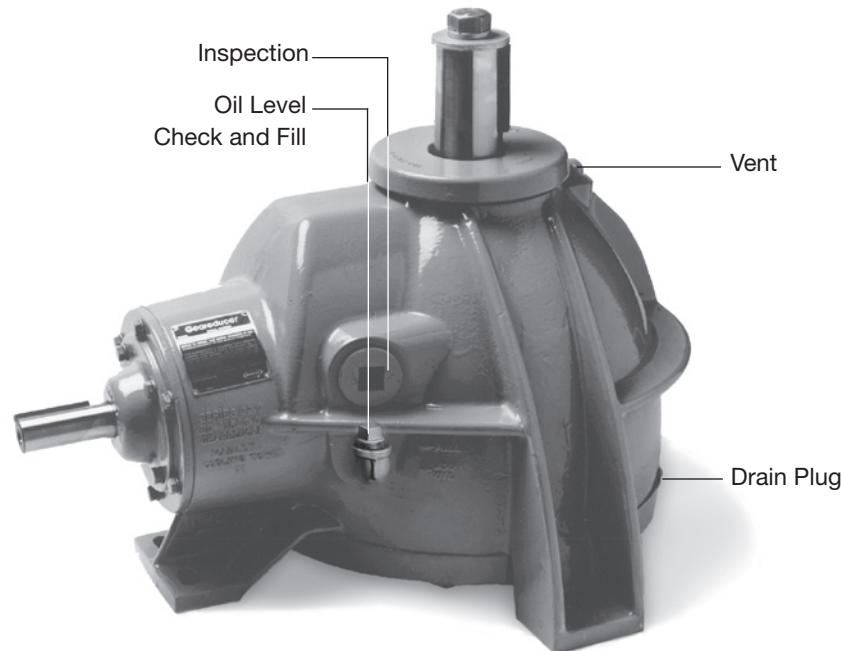

Figure 1 Service Fittings

### Protection Against Corrosion

All Marley Geareducer® units ship from the factory with a protective coating of epoxy enamel paint on all unmachined parts and with rust-proofing oil and grease on machined surfaces. Machined surface coatings normally protect the Geareducer against atmospheric corrosion during storage periods for up to six months. However, if oil is added to the Geareducer, the new oil will dissolve the rust-proofing grease and require that the Geareducer be run once a week to keep a protective coating of oil on all interior machined surfaces.

Check Geareducer exterior yearly and touch up with epoxy paint if required. If your Geareducer is equipped with an oil gauge and drain line, coat any exposed threads at pipe joints to prevent corrosion.

### Alignment

In order to assure long service life, the Geareducer and motor must be level, and the drive shaft or coupling must be properly aligned. Refer to the alignment instructions in the Driveshaft or Coupling Manual shipped with the cooling tower. Copies are also available from your local Marley sales representative.

### Initial Operation

Check to be sure that the Geareducer is filled with oil and that there are no visible oil leaks. If equipped with an external dipstick/oil level gauge, be sure the oil full mark corresponds with the full level at the Geareducer.

**Note**—If this tower is equipped with a two-speed motor, allow a time delay of at least 20 seconds when switching from high speed to low speed. Allow a time delay of at least two minutes when changing direction of fan rotation. Failure to provide these delays may significantly reduce equipment service life.

### Lubricants

To insure maximum performance and service life, it is recommended Marley factory lubricants be used in all Marley Geareducers. Marley lubricants can be purchased through your local Marley sales representative.



## / Operation and Service /

If lubricants other than Marley factory lubricants are used, they must not contain any additives (such as detergents or EP additives) which are adversely affected by moisture and could reduce the service life of the Geareducer. The responsibility for use of lubricants other than Marley factory lubricants rests with the customer/owner and the lubricant supplier.

**Note**—Geareducer is designed for 5-year oil change intervals. To maintain five-year change intervals, use only Marley Gearlube. Marley Gearlube must be inspected every six months to ensure the oil has not been contaminated. If turbine-type mineral oil is used the oil must be changed every six months.

Seasonal temperature changes may require one viscosity of oil for summer operation and another for winter operation. Refer to the tables below for the seasonal selection information.

Winter or Summer	Severe Duty/High Temperature
Air Temperature at Geareducer	
Below 110°F (43°C)	Above 110°F (43°C)
<b>ISO 150</b>	<b>ISO 220</b>

**Table 1** Synthetic oil—5-year oil change interval

Maintenance Service	Monthly	Semi-annually	Seasonal Startup or Annually
<b>Geareducer Drive:</b>			
Inspect and tighten all fasteners including oil plug		<b>x</b>	<b>x</b>
Check for and repair oil leaks	<b>x</b>	<b>x</b>	<b>x</b>
Check oil level	<b>x</b>	<b>R</b>	<b>x</b>
Change oil		<b>R</b>	<b>R</b>
Make sure vent is open		<b>x</b>	<b>x</b>
Check driveshaft or coupling alignment			<b>x</b>
Inspect and tighten driveshaft or coupling fasteners			<b>x</b>
Check driveshaft or coupling bushing / flex elements for unusual wear			<b>x</b>
<b>Lube Lines (if equipped)</b>			
Check for oil leaks in hoses and fittings	<b>x</b>	<b>R</b>	<b>x</b>

**R** – Refer to instructions within this manual

Note: It is recommended at least weekly, that the general operation and condition be observed. Pay particular attention to any changes in sound or vibration that may signify a need for closer inspection.

# / Operation and Service /

## Scheduled Maintenance

**⚠ Warning**—Make certain that mechanical equipment is inoperable during periods of maintenance—or during any situation of possible endangerment to personnel. If your electrical system contains a disconnect switch, lock it out until the period of exposure to injury is over.

**Monthly**—Check Geareducer oil level. Shut down the unit and allow 5 minutes for the oil level to stabilize. Add oil if required, noting the addition in your maintenance log. If equipped with an external dipstick/oil level gauge, small quantities of oil can be added at that location.

**Semi-annually**—Check that all the assembly bolts and cap screws are tight, that oil plugs and pipe connections are in place and free from leaks, and that the vent on the Geareducer (and external dipstick/oil level gauge, if present) is clear—a clogged vent can lead to oil leaks. If using turbine-type mineral oil, change oil—see **Changing Geareducer Oil** for instructions. Intermittent operation and extended periods of downtime can cause condensation of water in the oil.

**Annually**—Check mechanical equipment anchor bolts, drive shaft coupling bolts, and coupling set screws. Tighten as required.

**Every 5 Years**—Change oil. Geareducer was designed for 5-year oil change intervals. Perform **Monthly** and **Annual** maintenance checks prescribed above. To maintain five-year change intervals, use only Marley Gearlube.

## Changing Geareducer Oil

Drain the Geareducer oil by removing the drain plug. See **Figure 1** for location. If equipped with an external dipstick/oil level gauge, remove the drain plug at that location, and drain the entire system.

To maximize service life of the Geareducer, remove a sample from the drained oil and look for evidence of foreign material, such as water, metal shavings or sludge, or send the oil sample to an oil analysis lab for inspection. If you find unacceptable condensation or sludge, flush the Geareducer with mineral oil before refilling.

After inspection is complete, fill the Geareducer with **10 quarts** (9.5 liters) of oil. See **Figure 1** for location. If the Geareducer is equipped with an external dipstick/oil level gauge an additional 2 to 3 quarts (1.9 to 2.8 liters) of oil will be required. Be certain that the vent on the Geareducer (and external dipstick/oil level gauge, if present) is not plugged. Verify that

the gauge/drain line is full and that there aren't any leaks at the connections.

## Protection Against Corrosion

Check Geareducer exterior yearly and touch up with epoxy paint if required. If your Geareducer is equipped with an oil gauge and drain line, coat any exposed threads at pipe joints to prevent corrosion.

## Repair and Overhaul

If your Geareducer ever needs replacement or repair, we recommend returning the unit to a Marley factory service center. Contact your Marley sales representative to discuss course of action. A factory reconditioned Geareducer carries a one year warranty. The Order Number on your cooling tower will be required if the Geareducer is shipped back to the factory for repair. Obtain a **"Customer Return Material"** tag from the Marley sales representative in your area. To find your Marley sales representative call **913 664 7400** or check the internet at **www.spxcooling.com**.

Major repairs require the use of a fully equipped machine shop. If you decide to repair or overhaul your Geareducer, refer to the **Field Repair Section** and **Geareducer Parts List**.

**/ Field Repair /**

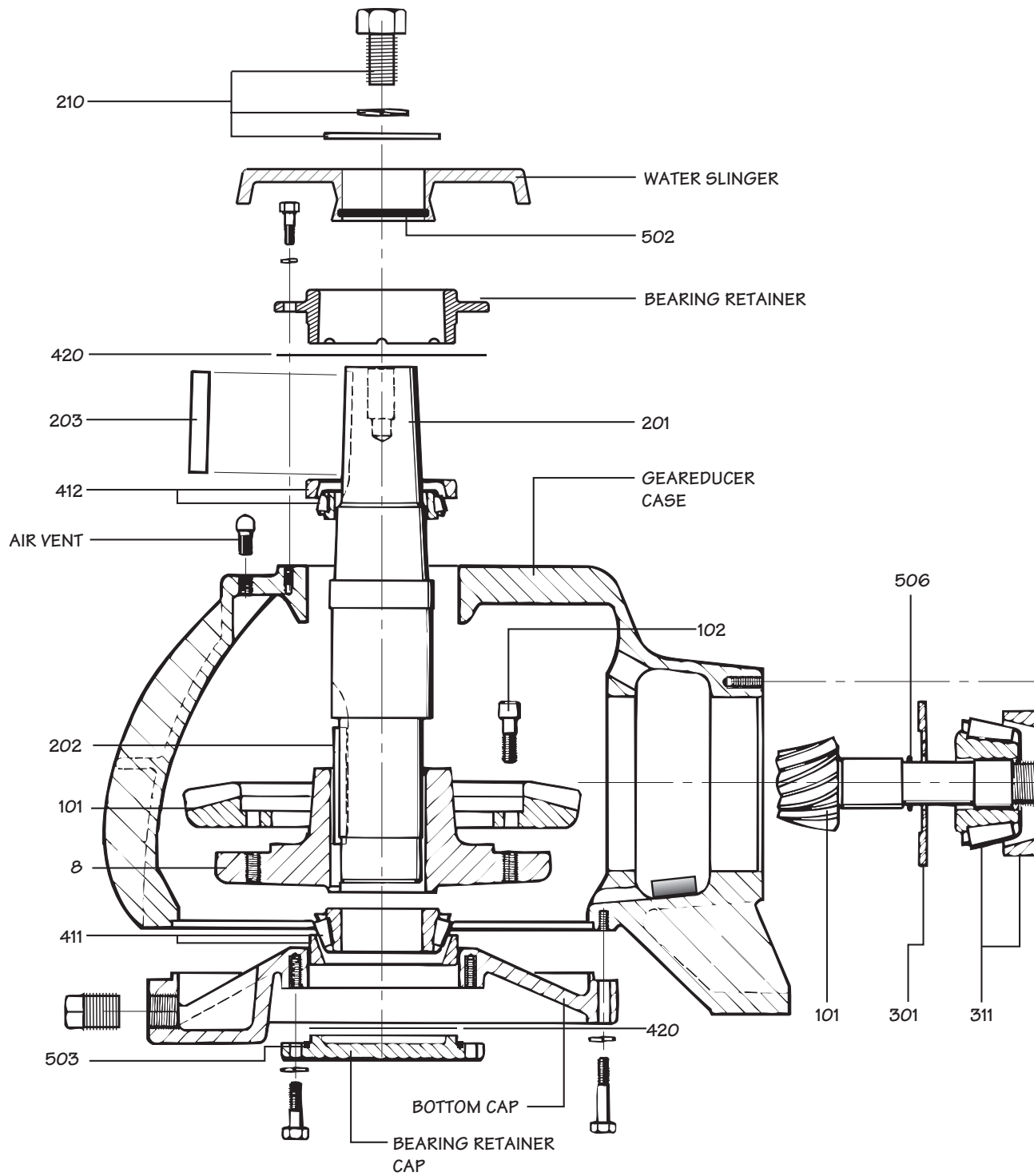
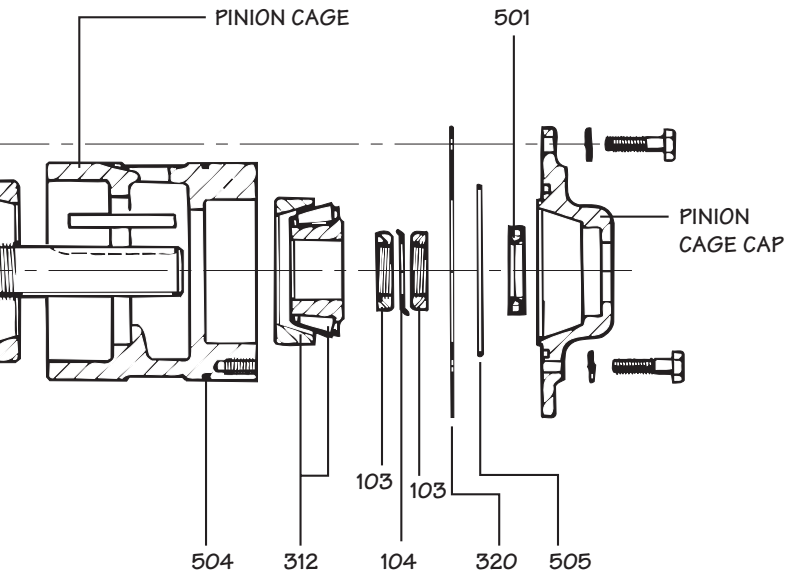

Figure 2 Exploded Cross Section

## Parts List

- 1 Complete Geareducer Assembly.
- 8 Ring Gear Hub.
- 100 Spiral Bevel Gear Set.
  - 101 Set of matched spiral bevel gears including integral pinion shaft with key.  
Gear ratios as follows:  
3.45 to 1    3.79 to 1    4.10 to 1  
4.56 to 1    5.11 to 1    5.50 to 1  
6.12 to 1    6.50 to 1    7.33 to 1
  - 102 Ring gear attaching hardware.
  - 103 Locknuts.
  - 104 Lockwasher.
  
- 200 Fan Shaft Set.
  - 201 Fan shaft.
  - 202 Ring gear hub key. This is a special high strength key. It must be obtained from Marley.
  - 203 Fan key.
  - 210 Fan attaching hardware.  
Cap screws and washers.
  
- 301 Oil Slinger.
- 310 Set of Two Pinion Shaft Bearings.
  - 311 Head, tapered roller bearing.
  - 312 Tail, tapered roller bearing.
- 320 Pinion Cage Shims.
- 410 Fan Shaft Bearing Set.
  - 411 Lower tapered roller bearing.
  - 412 Upper tapered roller bearing.
- 420 Fan Shaft Shims.
  
- 500 O-Rings Set.
  - 502 Water slinger O-ring, 3" ID x 3¼" OD x ⅛".
  - 503 Bearing retainer O-ring, 5" ID x 5¼" OD x ⅛".
  - 504 Pinion cage O-ring, 5¾" ID x 6" OD x ⅛".
  - 505 Pinion cage cap O-ring, 4" ID x 4¾" OD x ⅜".
  - 506 Oil slinger O-ring, 1<sup>15</sup>/<sub>16</sub>" ID x 2<sup>1</sup>/<sub>8</sub>" OD x 5<sup>3</sup>/<sub>32</sub>".
  
- 501 Pinion Shaft Oil Seal.



# / Field Repair /

## General

Geareducers can be repaired in the field—however, major repairs require the use of a fully equipped machine shop. When field repair or replacement of parts is necessary, the following procedure is recommended for the disassembly and assembly of the unit. If any O-ring, oil seal or gasket is to be reused, care should be taken not to damage it during disassembly. Parts which contain O-rings or seals should not be jerked or twisted past a shoulder or edge. These parts are marked with an asterisk (\*) in the description below. O-rings, oil seal and gaskets should be carefully inspected for damage before being reinstalled. Always use new O-rings and oil seal during a major overhaul.

## Disassembly

*Part numbers and references—refer to Figure 2 and 3.*

1. Remove drain plug and drain oil.
2. Remove outer ring of bolts in pinion cage cap and remove pinion subassembly\*.

**Note**—The thickness of the shim pack (320) is important in resetting the gears. The shim pack should either be saved or carefully measured with a micrometer. If the gears are to be replaced, record the pinion setting distance that is etched on the pinion gear.

3. Remove water slinger\*.
4. Turn case upside down and remove bearing retainer cap\* and shim pack (420).

**Note**—The thickness of this shim pack is important in the backlash setting of the gears. The shim pack should either be saved or carefully measured with a micrometer.

5. Remove bottom cap and fan shaft assembly.
6. Turn Geareducer case right side up and remove bearing retainer and shim pack (420).

**Note**—The thickness of this shim pack is important in setting the fan shaft bearing endplay. This pack should be saved or carefully measured with a micrometer.

7. Remove bearing cups (411 and 412) from the bottom cap and Geareducer case using a soft metal punch or mallet.

## Pinion Cage Disassembly

1. Remove pinion cage cap\* from pinion cage.
2. Remove O-rings\* (504 and 505).

3. Remove locknuts and lockwasher (103 and 104) then press pinion shaft (101) out of pinion cage. This will free tail bearing cone (312). A hydraulic press or jack is recommended for removing or assembling press fit parts.
4. Press oil slinger\*, O-rings\* (301 and 506), and head bearing cone (311) from the pinion shaft. Bearings must not be exposed to dirt, dust or moisture.
5. Press bearing cups (311 and 312) out of pinion cage.

## Fan Shaft Disassembly

1. Remove ring gear (101) from the ring gear hub (8).
2. Press ring gear hub and lower bearing cone (411) off of the fan shaft (201).
3. Remove lower fan shaft key (202).
4. Press the top bearing cone (412) off of the shaft.

## Assembly

Before assembling a new pinion gear in the pinion cage, check match numbers on pinion gear and spiral bevel ring gear to be certain that they are a matched set. Gears are lapped in matched sets at the factory and should not be separated. Numbers are etched on both the pinion and ring gear as illustrated in **Figure 4**.

All parts that are to be reused should be thoroughly cleaned before being reinstalled. Do not remove new bearings from packaging until ready to use. Clean all bearings (new or used). Do not spin dry bearings. Take each bearing set and roll the cup on the cone to note any roughness. Replace bearing if necessary. If bearings cannot be installed immediately after cleaning, lubricate and cover to protect against dust, moisture, etc.

If a press is not available to install bearing cones, they can be heated as long as the temperature does not exceed 275°-300°F (135°-149°C). If the bearings get hotter than this, they will begin to draw and soften. Bearings can be heated with infrared lamps or with oil baths. If an oil bath is used, the bearing should be supported an inch or so above the pan to prevent local overheating.

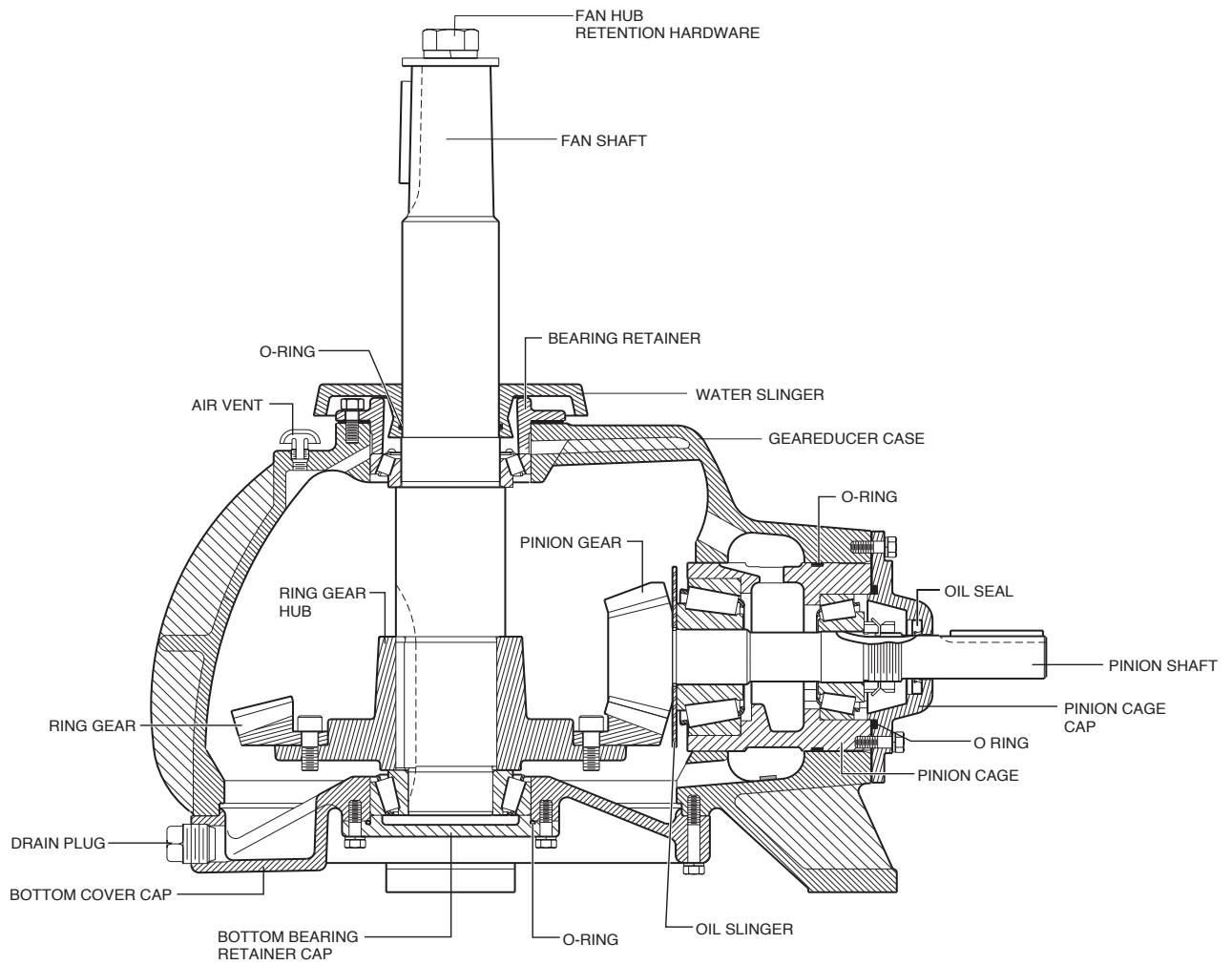

Figure 3 Cross Section

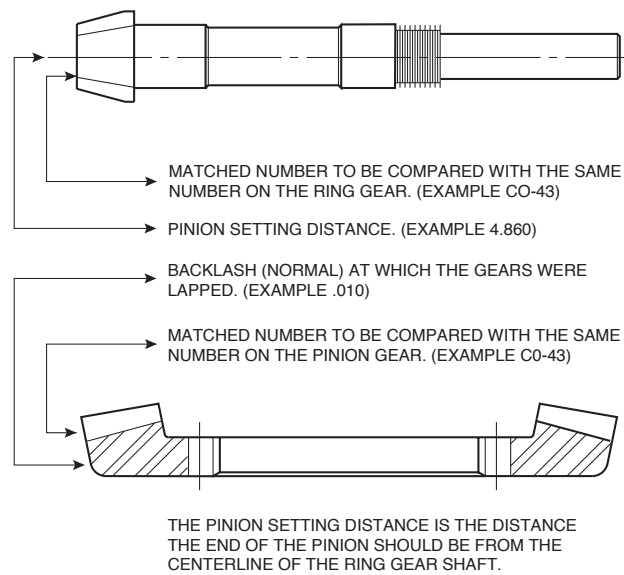

Figure 4 Gear Match Numbers and Setting Data

# / Field Repair /

## Pinion Cage Subassembly

1. Place O-ring (506) on pinion shaft (101).
2. Place oil slinger (301) on pinion shaft.
3. Press head bearing cone (311) on pinion shaft making sure oil slinger and bearing are against gear.
4. Press bearing cups (311 and 312) into pinion cage.
5. Lower pinion cage on pinion shaft, until head bearing cone and cup mate.
6. Press tail bearing cone (312) on pinion shaft until it mates with its bearing cup.
7. Install locknuts and lockwasher (103 and 104). Tighten nuts on bearing cone until 5 to 15 in·lb<sub>f</sub> (565-1695 mN·m) of bearing preload is obtained. Bearing preload is the resistance in the bearings to shaft rotation measured in in·lb<sub>f</sub> required to rotate the shaft at uniform velocity. Preload is necessary to insure the stability of the gear engagement. Crimp the lockwasher to hold the two nuts in place.
8. Install O-ring (504) in groove.
9. Press oil seal (501) onto pinion shaft. 10. Position O-ring (505) and push cap—with seal and sleeve—in place on shaft. Attach cap to pinion cage and slide sleeve from cap.
11. Record the pinion setting distance that is etched on the pinion gear.

## Installation of Fan Shaft

1. Press ring gear hub (8) and the upper and lower bearing cones (411 and 412) on the fan shaft (201). Install ring gear (101) on ring gear hub and tighten cap screws to 90 ft·lb<sub>f</sub> (123 N·m).
2. Install upper fan shaft bearing cup (412) and bearing retainer without shims.
3. Turn the Geareducer case upside down and install the fan shaft assembly seating the upper fan shaft bearing cone into its cup. Install the lower bearing cup (411).
4. Install the bottom cover cap using sealer as indicated in **Figure 5** and tighten cap screws to 25 ft·lb<sub>f</sub> (34 N·m). Use old shim pack or make up equivalent thickness shim pack (420) and install the bottom bearing retainer cap. Do not install the O-ring for the bottom bearing retainer at this time. Tighten the cap screws to 25 ft·lb<sub>f</sub> (34 N·m).

5. Turn the Geareducer right side up and rotate the fan shaft several turns in each direction to seat the bearing rollers. With a dial indicator and using the Geareducer case as a reference, measure and adjust the fan shaft bearings to .003-.005" (.076-.127mm) endplay. The endplay is adjusted by adding shims (Part 420) under the bearing retainer.

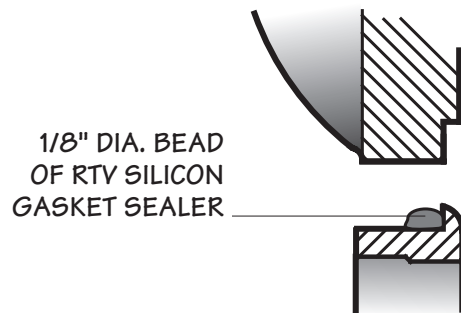

Figure 5 Flange Seal of Bottom Bearing Cap

## Installation of Pinion Cage

1. The "X" marked pinion and gear teeth should be clearly identified with chalk or other markings which can be seen from the inspection opening or the bottom of the case.
2. Find the difference between the pinion setting distance of the old gear and the new pinion gear and adjust the old shim pack (320) or make a new shim pack to compensate for the different setting distances.

Example:

Pinion setting distance of old gear	4.883
Pinion setting distance of new gear	4.878
<i>Difference</i>	.005

Remove .005 from shim gap.

3. Install shims (320) and pinion cage subassembly.

**Note**—Care must be taken not to damage the pinion gear teeth by forcing them into the ring gear teeth.

# / Field Repair /

## Gear Setting Procedure

The proper mounting of the gear set is essential to obtain long life and smooth operation of the gears. The pinion and ring gears were positioned approximately in the preceding steps. The correct gear position is determined by the gear tooth contact pattern and by the backlash.

With the "X" marked tooth on the pinion gear engaged between the two "X" marked teeth on the ring gear, check the backlash with a dial indicator as shown in **Figure 6**. Lock the pinion shaft against rotation. The amount of movement of the fan shaft, measured at a distance equal to the outside radius of the ring gear is the backlash. The backlash on the 6.50/1 gear set should be between .013 and .018" (.33 and .46mm). The backlash on all other ratios should be between .010 and .015" (.25 and .38mm). With the "X" teeth engaged, the backlash should be approximately in the middle of the allowable range. Check the backlash at three other points around the ring gear to be sure the backlash is within the specified limits. Adjust ring gear axially by removing or adding shims (420) at bottom bearing retainer.

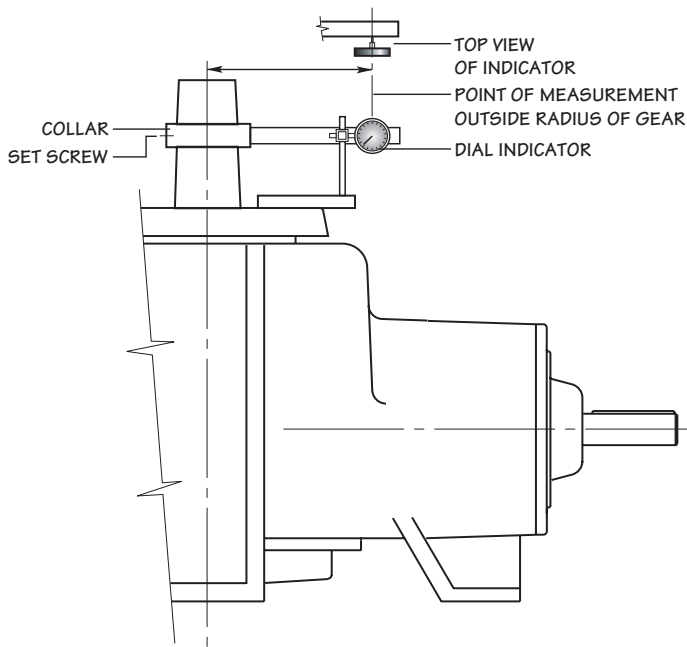

Figure 6 Gear Backlash Measurement

**Note**—To maintain bearing adjustment corresponding shim (420) adjustment must be made at the bearing retainer.

**Example:** Removing .003" shims at the bottom bearing retainer requires the addition of .003" shims at the top bearing retainer to maintain correct bearing adjustment.

Recheck the backlash to make sure it is within the proper limits.

With gears adjusted to the proper backlash, blue (Prussian blue in oil) the pinion teeth. By using a long handled brush or swab, the pinion teeth can be reached through the inspection opening. Drive the pinion by turning the fan shaft in both directions for several revolutions. Observe the markings on both gears on both sides of the teeth. Compare the markings with the contact pattern shown in **Figure 7**.

If contact pattern is incorrect, adjust the pinion position with shims between the pinion cage cap and Geareducer case.

When tooth contact is correct, recheck backlash. If necessary, adjust ring gear to obtain proper backlash and recheck contact pattern. Proper contact is more important of the two. On a used set of gears, it may be necessary to set the gears with slightly greater backlash in order to obtain proper tooth contact. Should a condition be encountered where correct contact cannot be obtained, contact your local Marley sales representative for information on factory repair service.

## Final Assembly

1. Remove bottom bearing retainer cap and install the O-ring (503). Reinstall the bottom bearing retainer cap and tighten the cap screws to 25 ft-lb<sub>f</sub> (34 N·m).
2. Install O-ring (502) in water slinger.
3. Install water slinger on fan shaft (8).
4. Replace air vent and all pipe plugs.
5. Fill with lubricant selected from **Table I**.

# / Field Repair /

## Correct Pinion and Ring Gear Tooth Contact Patterns

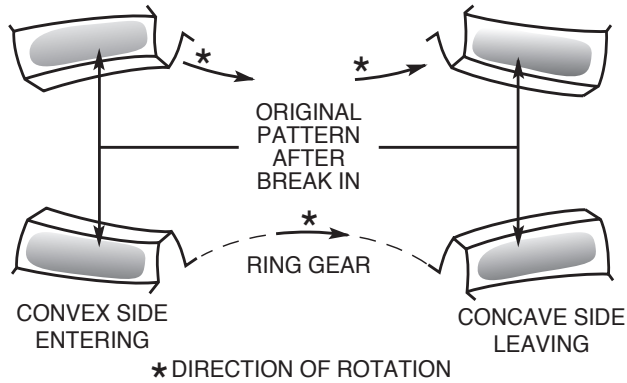

## Incorrect Ring Gear Tooth Contact Patterns

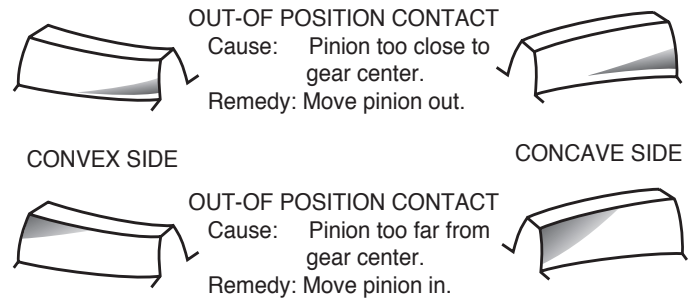

Figure 7 Tooth Contact Pattern—Correct and Incorrect

**SPX**<sup>®</sup>

COOLING TECHNOLOGIES

7401 WEST 129 STREET | OVERLAND PARK, KANSAS 66213 UNITED STATES | 913 664 7400 | [spxcooling@spx.com](mailto:spxcooling@spx.com) | [spxcooling.com](http://spxcooling.com)

In the interest of technological progress, all products are subject to design and/or material change without notice.  
©2008 SPX Cooling Technologies, Inc. | Printed in USA

Manual 99-1260D