

/ Marley MD Cooling Tower /

Engineering Data & Specifications

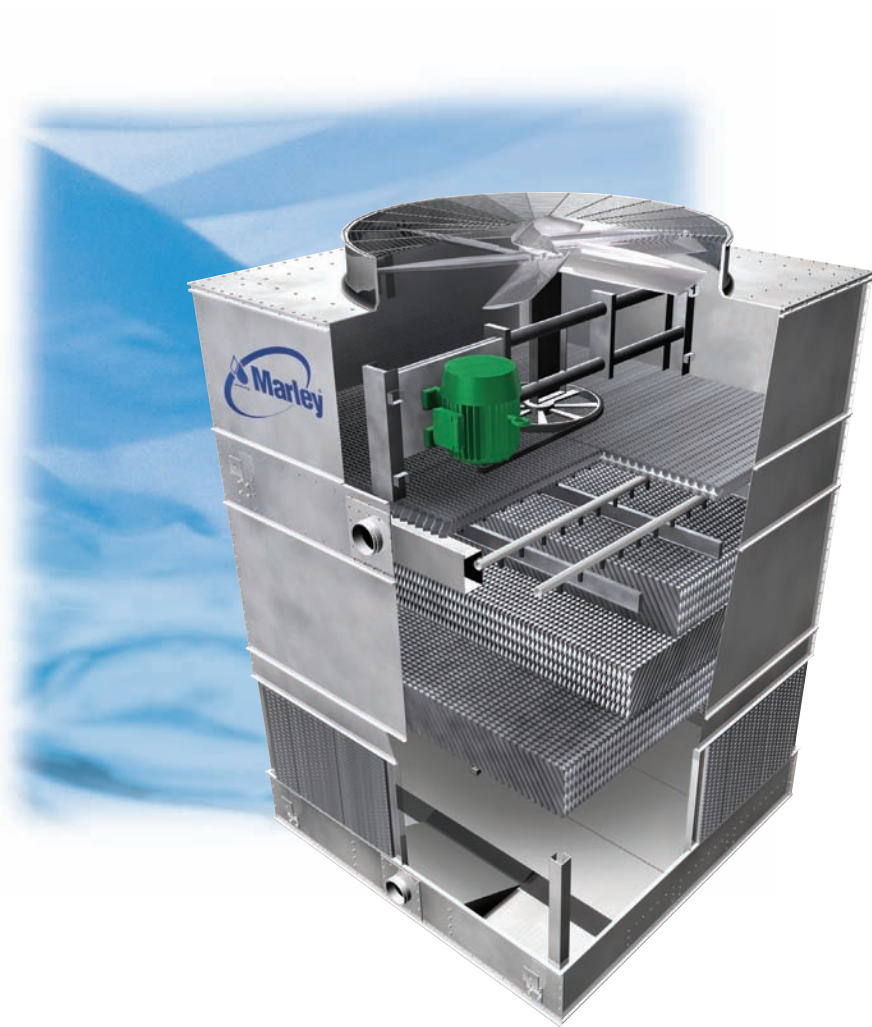

Engineering Data

Schematic	6
Support	22
Outlet Connection	24
Hoisting Info	25
Freeze Prevention	26
Water Quality	27

Specifications / Base

Base	28
Thermal Performance	28
Performance Warranty	28
Design Loading	29
Construction	29
Mechanical Equipment	29
Fill, Louvers and Drift Eliminators	31
Hot Water Distribution System	31
Casing and Fan Guard	31
Access	31
Collection Basin	32
Warranty	32

Specifications / Options

Stainless Steel Options

Stainless Steel Collection Basin	33
All Stainless Steel Cooling Tower	33

Convenience and Safety Options

Mechanical Access Platform	34
Ladder Extension	34
Ladder Safety Cage	34
Motor Davit	34
Motor and Fan Davit	35

Control Options

Fan Motor Starter Control Panel	35
Vibration Limit Switch	36
Basin Heater	36
Fan Motor Variable Speed Drive	36

Miscellaneous Options

Equalizer Flume Weir Gates	39
Premium Efficiency Motor	39
Sound Control	40

■ Air Movement Package

- High efficiency fan—wide-chord design for maximum efficiency at low fan tip speeds
- Eased inlet fan cylinder—ensures full area, low turbulent airflow through the cylinder
- Spherical roller bearings are rated at an L₁₀ life of 100,000 hours
- TEFC Fan Motor—1.15 service factor, variable torque, and specially insulated for cooling tower duty
- The MD Series air movement package including the structural support—guaranteed against failure for a period of five full years. The motor is warranted separately by the motor manufacturer

■ Water Distribution System

- Pressurized spray system distributes water evenly over the fill
- Low-clog polypropylene nozzles—delivers precise distribution of water over the fill area
- Marley MC thermoformed PVC film fill assembled into packs for ease of removal and cleaning
- Marley XCEL drift eliminators—limit drift losses to no more than .001% of the design GPM flow rate

■ Structure

- Induced-draft, counterflow design may require less plan area than crossflow towers typically use
- Series 300 stainless steel, 316 stainless steel or heavy mill galvanized steel construction
- Factory assembled—ensures final field installation will be hassle-free
- Triple-pass PVC inlet louvers—limits splash-out and eliminate sunlight from entering the collection basin



MD towers are galvanized steel, factory assembled, counterflow cooling towers, designed to serve air conditioning and refrigeration systems as well as light to medium industrial process loads on clean water. The Marley MD evolved from a factory-assembled concept of towers pioneered by Marley some 75 years ago, and incorporate all of the design advancements that our customers have found valuable. MD towers represent the current state of the art in this cooling tower category.

The specifications portion of this publication not only relates the language to use in describing an appropriate MD cooling tower—but also defines why certain items and features are important enough to specify with the intention of insisting upon compliance by all bidders. The left hand column of pages 28 thru 40 provides appropriate text for the various specification paragraphs, whereas the right hand column comments on the meaning of the subject matter and explains its value.

Pages 33 thru 40 indicate those paragraphs which will result in the purchase of a basic cooling tower—one that accomplishes the specified thermal performance, but which will lack many operation—and maintenance-enhancing accessories and features that are usually desired by those persons who are responsible for the continuing operation of the system of which the cooling tower is part. It will also incorporate those standard materials which testing and experience has proven to provide acceptable longevity in normal operating conditions.

Pages 33 thru 39 provide paragraphs intended to add those features, components, and materials that will customize the cooling tower to meet the user's requirements.

MD5008 SINGLE CELL

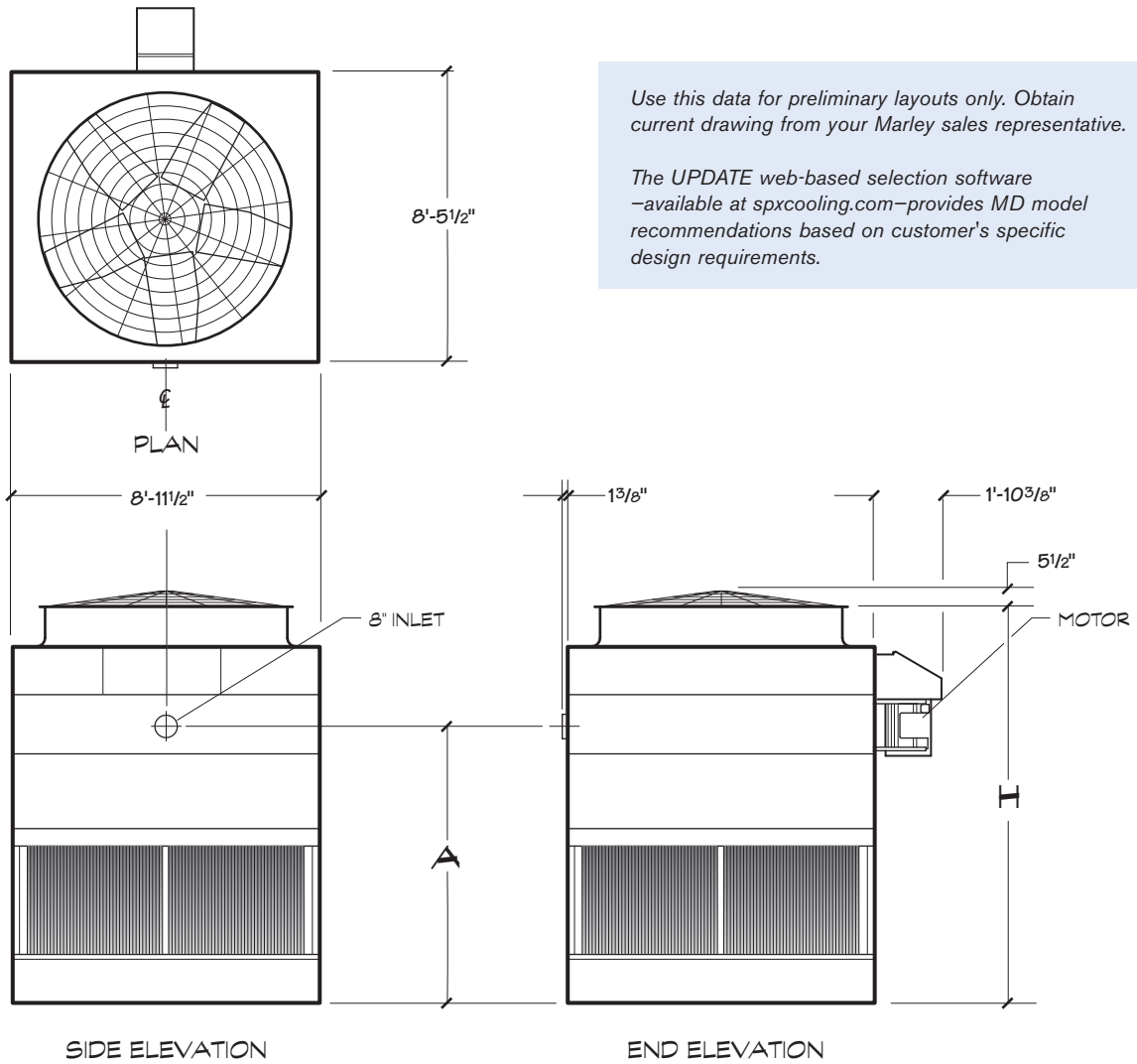

Use this data for preliminary layouts only. Obtain current drawing from your Marley sales representative.

The UPDATE web-based selection software –available at spxcooling.com–provides MD model recommendations based on customer's specific design requirements.

MD5008 SINGLE CELL

Model note 2	Nominal Tons note 3	Motor hp	dBA 5'-0" from air inlet face	Dimensions		Design Operating Weight lb	Shipping Weight lb	
				H	A		Weight/Cell	Heaviest Section
MD5008MAC1L	165	7.5	80	10'-9 ¹¹ / ₁₆ "	7'-1 ¹ / ₈ "	6726	3752	1965
MD5008MLC1L	163	7.5	79					
MD5008NAC1L	179	10	81					
MD5008NLC1L	179	10	79					
MD5008PAC1L	202	15	81					
MD5008PLC1L	202	15	80					
MD5008QAC1L	216	20	81					
MD5008QLC1L	216	20	80					
MD5008MAD1L	180	7.5	80	11'-9 ¹¹ / ₁₆ "	8'-1 ¹ / ₈ "	7003	4029	2064
MD5008MLD1L	177	7.5	79					
MD5008NAD1L	197	10	81					
MD5008NLD1L	196	10	79					
MD5008PAD1L	223	15	81					
MD5008PLD1L	223	15	80					
MD5008QAD1L	239	20	81					
MD5008QLD1L	238	20	80					
MD5008MAF1L	189	7.5	80	12'-9 ¹¹ / ₁₆ "	9'-1 ¹ / ₈ "	7280	4306	2341
MD5008MLF1L	185	7.5	79					
MD5008NAF1L	207	10	81					
MD5008NLF1L	206	10	79					
MD5008PAF1L	234	15	81					
MD5008PLF1L	234	15	80					
MD5008QAF1L	255	20	81					
MD5008QLF1L	257	20	80					

NOTE

- 1 Use this bulletin for preliminary layouts only. Obtain current drawings from your Marley sales representative. All table data is per cell.
- 2 Last two characters of the model number indicate number of cells and cell configuration.
- 3 Nominal tons are based upon 95°F HW, 85°F CW, 78°F WB and 3 GPM/ton. The Marley **UPDATE** web-based selection software provides MD model recommendations based on specific design requirements.
- 4 Standard overflow is a 3" dia. M connection located on the side of the collection basin. Makeup water connection is 2" dia. M connection located on the side of the tower. A 3" M drain connection is located on the side of the collection basin.

MD5008 MULTICELL

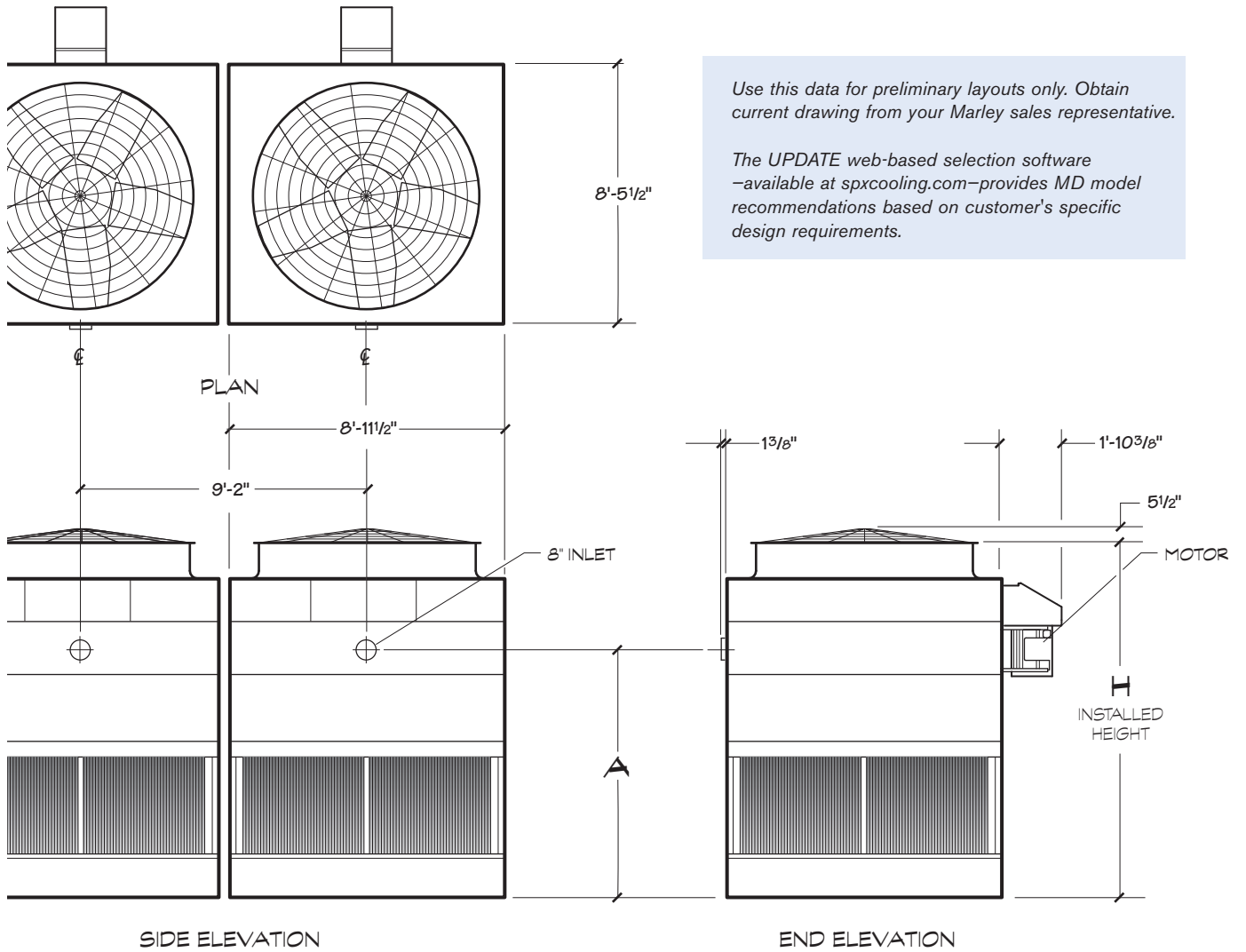

Use this data for preliminary layouts only. Obtain current drawing from your Marley sales representative.

The UPDATE web-based selection software –available at spxcooling.com–provides MD model recommendations based on customer's specific design requirements.

MD5008 MULTICELL

Model note 2	Nominal Tons note 3	Motor hp	dBA 5'-0" from air inlet face	Dimensions		Design Operating Weight lb	Shipping Weight lb	
				H	A		Weight/Cell	Heaviest Section
MD5008MAC2L	165	7.5	80	11'-6 ¹³ / ₁₆ "	7'-11"	6772	3798	1965
MD5008MLC2L	165	7.5	79					
MD5008NAC2L	179	10	81					
MD5008NLC2L	179	10	79					
MD5008PAC2L	202	15	81					
MD5008PLC2L	202	15	80					
MD5008QAC2L	217	20	81					
MD5008QLC2L	217	20	80					
MD5008MAD2L	180	7.5	80	12'-6 ¹³ / ₁₆ "	8'-11"	7049	4075	2110
MD5008MLD2L	180	7.5	79					
MD5008NAD2L	196	10	81					
MD5008NLD2L	196	10	79					
MD5008PAD2L	222	15	81					
MD5008PLD2L	222	15	80					
MD5008QAD2L	239	20	81					
MD5008QLD2L	239	20	80					
MD5008MAF2L	188	7.5	80	13'-6 ¹³ / ₁₆ "	9'-11"	7326	4352	2387
MD5008MLF2L	188	7.5	79					
MD5008NAF2L	205	10	81					
MD5008NLF2L	205	10	79					
MD5008PAF2L	234	15	81					
MD5008PLF2L	234	15	80					
MD5008QAF2L	251	20	81					
MD5008QLF2L	251	20	80					

NOTE

- 1 Use this bulletin for preliminary layouts only. Obtain current drawings from your Marley sales representative. All table data is per cell.
- 2 Last two characters of the model number indicate number of cells and cell configuration. Change as appropriate for your selection.
- 3 Nominal tons are based upon 95°F HW, 85°F CW, 78°F WB and 3 GPM/ton. The Marley **UPDATE** web-based selection software provides MD model recommendations based on specific design requirements.
- 4 Standard overflow is a 3" dia. M connection located on the side of the collection basin. Makeup water connection is 2" dia. M connection located on the side of the tower. A 3" M drain connection is located on the side of the collection basin.

MD5010 SINGLE CELL

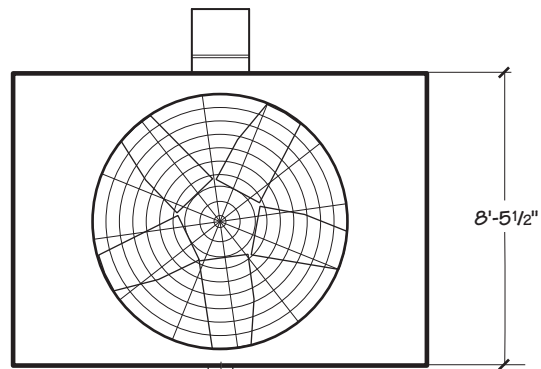

PLAN

11'-11 3/4"

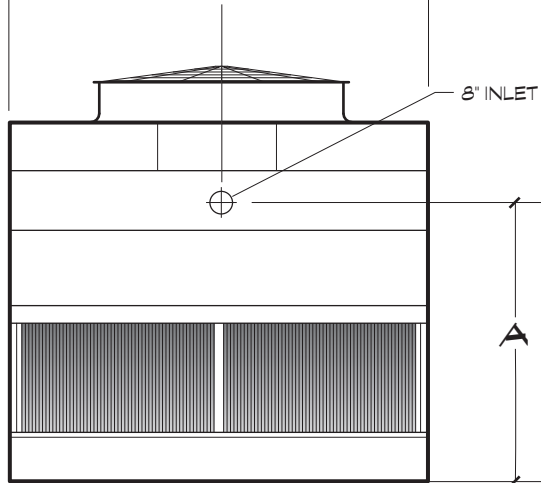

SIDE ELEVATION

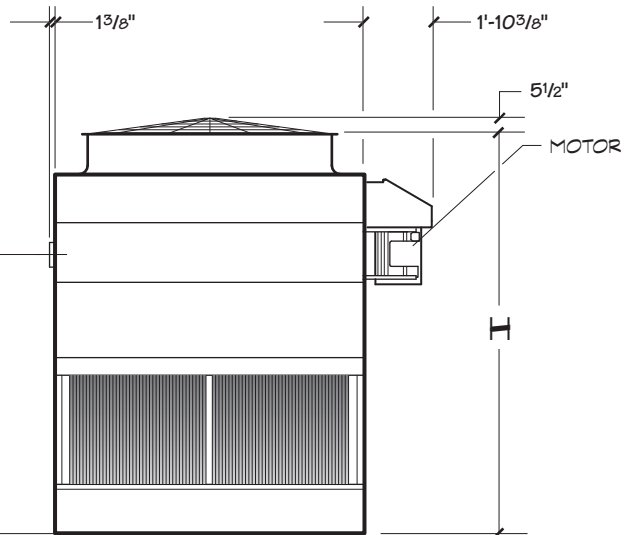

END ELEVATION

Use this data for preliminary layouts only. Obtain current drawing from your Marley sales representative.

The UPDATE web-based selection software –available at spxcooling.com–provides MD model recommendations based on customer's specific design requirements.

MD5010 SINGLE CELL

Model note 2	Nominal Tons note 3	Motor hp	dBA 5'-0" from air inlet face	Dimensions		Design Operating Weight lb	Shipping Weight lb	
				H	A		Weight/Cell	Heaviest Section
MD5010PAC1L	248	15	81	11'-2 ⁵ / ₁₆ "	7'-6 ¹ / ₂ "	8561	4584	2319
MD5010PLC1L	249	15	80					
MD5010QAC1L	269	20	81					
MD5010QLC1L	270	20	80					
MD5010RAC1L	286	25	81					
MD5010RLC1L	289	25	80					
MD5010PAD1L	279	15	81	12'-2 ⁵ / ₁₆ "	8'-6 ¹ / ₂ "	8920	4943	2624
MD5010PLD1L	280	15	80					
MD5010QAD1L	304	20	81					
MD5010QLD1L	305	20	80					
MD5010RAD1L	325	25	81					
MD5010RLD1L	329	25	80					
MD5010PAF1L	293	15	81	13'-2 ⁵ / ₁₆ "	9'-6 ¹ / ₂ "	9334	5357	2983
MD5010PLF1L	294	15	80					
MD5010QAF1L	317	20	81					
MD5010QLF1L	318	20	80					
MD5010RAF1L	341	25	81					
MD5010RLF1L	346	25	80					
MD5010SAF1L	360	30	81					
MD5010SLF1L	362	30	81					

NOTE

- 1 Use this bulletin for preliminary layouts only. Obtain current drawings from your Marley sales representative. All table data is per cell.
- 2 Last two characters of the model number indicate number of cells and cell configuration.
- 3 Nominal tons are based upon 95°F HW, 85°F CW, 78°F WB and 3 GPM/ton. The Marley **UPDATE** web-based selection software provides MD model recommendations based on specific design requirements.
- 4 Standard overflow is a 3" dia. M connection located on the side of the collection basin. Makeup water connection is 2" dia. M connection located on the side of the tower. A 3" M drain connection is located on the side of the collection basin.

MD5010 MULTICELL

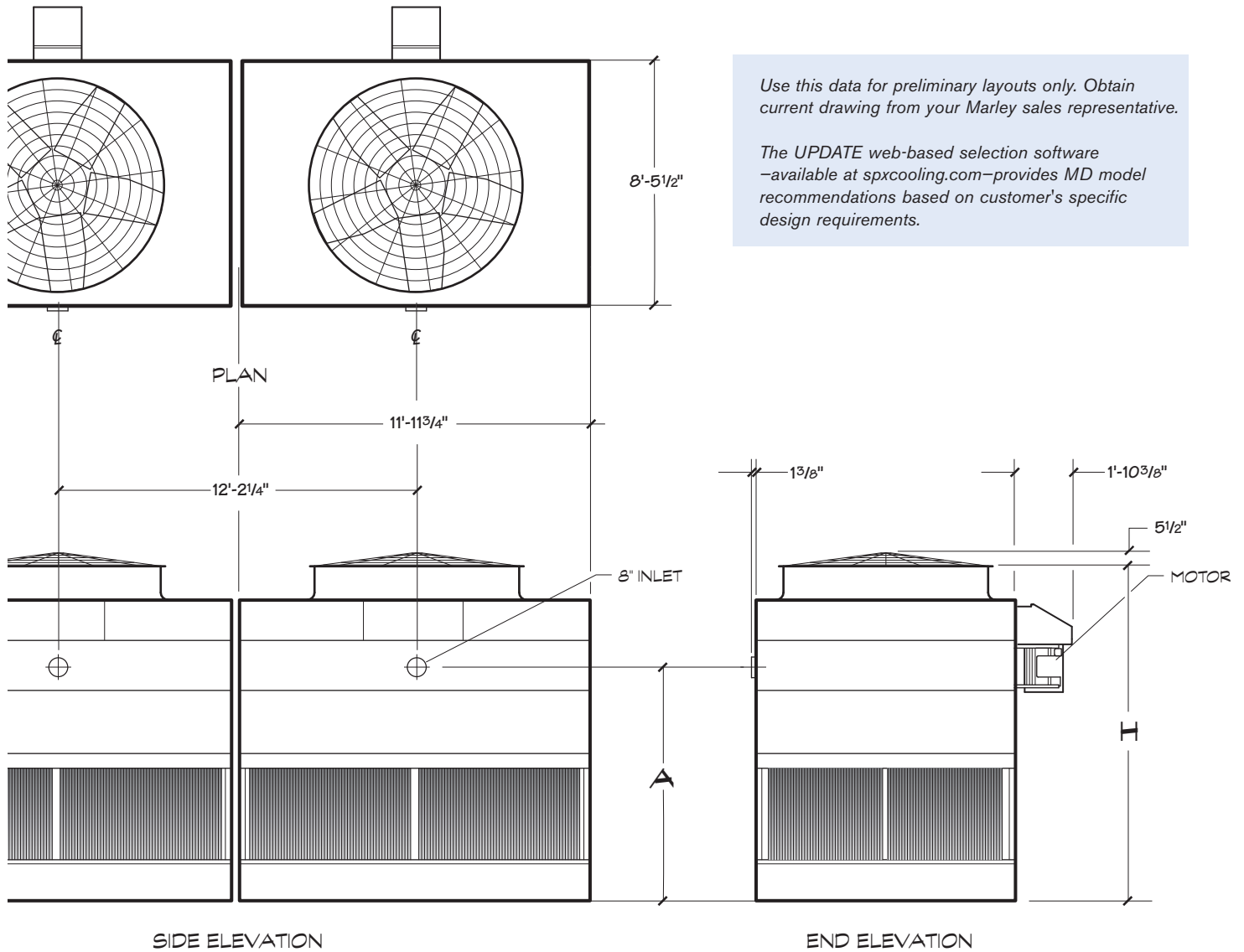

Use this data for preliminary layouts only. Obtain current drawing from your Marley sales representative.

The UPDATE web-based selection software –available at spxcooling.com–provides MD model recommendations based on customer's specific design requirements.

MD5010 MULTICELL

Model note 2	Nominal Tons note 3	Motor hp	dBA 5'-0" from air inlet face	Dimensions		Design Operating Weight lb	Shipping Weight lb	
				H	A		Weight/Cell	Heaviest Section
MD5010PAC2L	248	15	81	11'-10 ¹³ / ₁₆ "	8'-3"	8611	4634	2319
MD5010PLC2L	249	15	80					
MD5010QAC2L	269	20	81					
MD5010QLC2L	270	20	80					
MD5010RAC2L	286	25	81					
MD5010RLC2L	289	25	80					
MD5010PAD2L	279	15	81	12'-10 ¹³ / ₁₆ "	9'-3"	8970	4993	2674
MD5010PLD2L	280	15	80					
MD5010QAD2L	304	20	81					
MD5010QLD2L	305	20	80					
MD5010RAD2L	325	25	81					
MD5010RLD2L	329	25	80					
MD5010PAF2L	293	15	81	13'-10 ¹³ / ₁₆ "	10'-3"	9384	5407	3033
MD5010PLF2L	294	15	80					
MD5010QAF2L	317	20	81					
MD5010QLF2L	318	20	80					
MD5010RAF2L	341	25	81					
MD5010RLF2L	346	25	80					
MD5010SAF2L	360	30	81					
MD5010SLF2L	362	30	81					

NOTE

- 1 Use this bulletin for preliminary layouts only. Obtain current drawings from your Marley sales representative. All table data is per cell.
- 2 Last two characters of the model number indicate number of cells and cell configuration. Change as appropriate for your selection.
- 3 Nominal tons are based upon 95°F HW, 85°F CW, 78°F WB and 3 GPM/ton. The Marley **UPDATE** web-based selection software provides MD model recommendations based on specific design requirements.
- 4 Standard overflow is a 3" dia. M connection located on the side of the collection basin. Makeup water connection is 2" dia. M connection located on the side of the tower. A 3" M drain connection is located on the side of the collection basin.

MD5016 SINGLE CELL

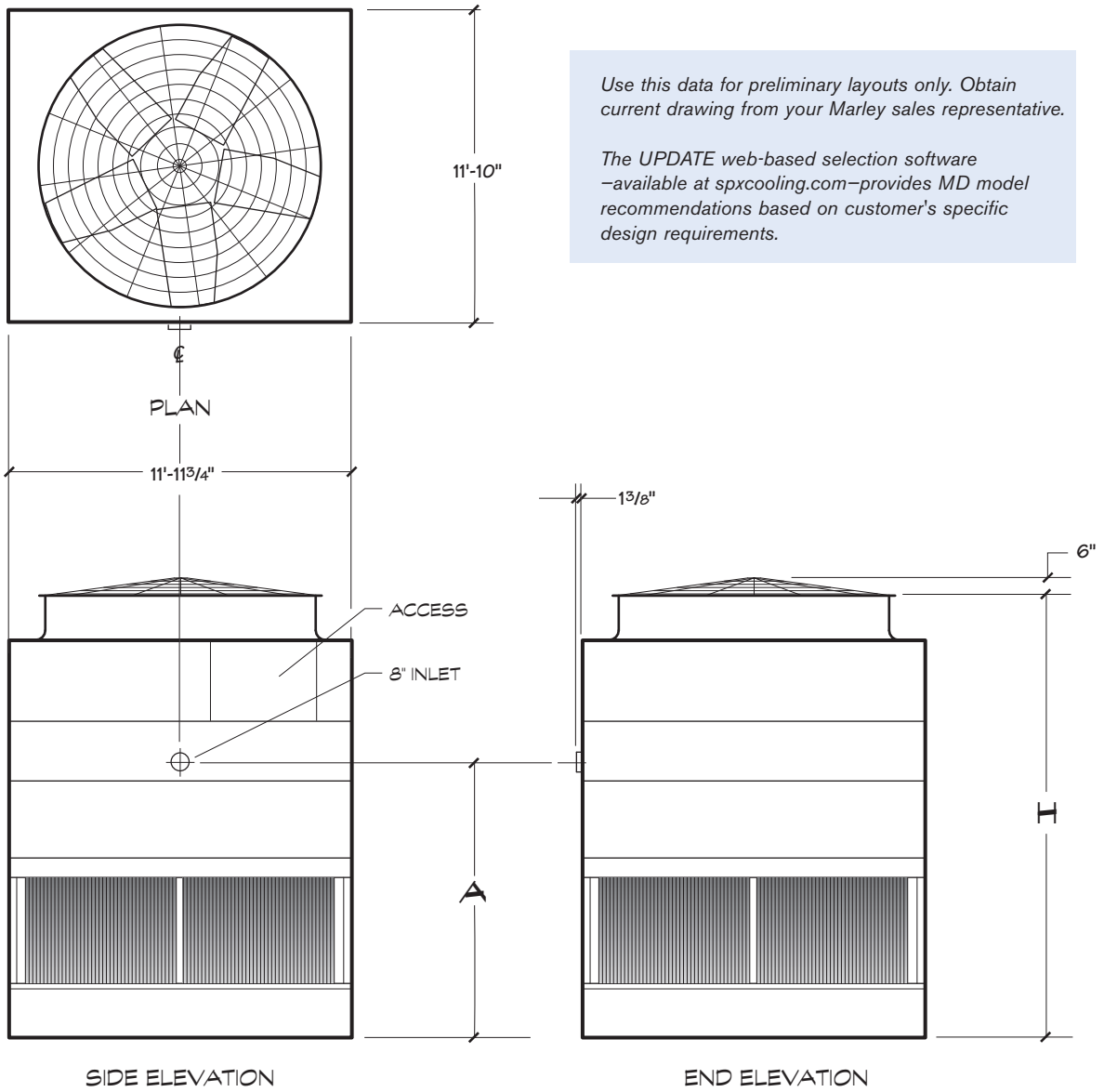

MD5016 SINGLE CELL

Model note 2	Nominal Tons note 3	Motor hp	dBA 5'-0" from air inlet face	Dimensions		Design Operating Weight lb	Shipping Weight lb	
				H	A		Weight/Cell	Heaviest Section
MD5016PAC1L	317	15	79	13'-10 ⁷ / ₈ "	8'-3 ³ / ₁₆ "	12798	7109	3771
MD5016PLC1L	320	15	78					
MD5016QAC1L	345	20	80					
MD5016QLC1L	348	20	79					
MD5016RAC1L	369	25	80					
MD5016RLC1L	372	25	79					
MD5016SAC1L	390	30	81					
MD5016SLC1L	394	30	80					
MD5016PAD1L	350	15	79	14'-10 ⁷ / ₈ "	9'-3 ³ / ₁₆ "	13423	7734	3886
MD5016PLD1L	353	15	78					
MD5016QAD1L	383	20	80					
MD5016QLD1L	384	20	79					
MD5016RAD1L	410	25	80					
MD5016RLD1L	412	25	79					
MD5016SAD1L	436	30	81					
MD5016SLD1L	437	30	80					
MD5016TAD1L	475	40	82	15'-10 ⁷ / ₈ "	10'-3 ³ / ₁₆ "	13933	8244	4358
MD5016TLD1L	471	40	80					
MD5016PAF1L	368	15	79					
MD5016PLF1L	370	15	78					
MD5016QAF1L	403	20	80					
MD5016QLF1L	401	20	79					
MD5016RAF1L	431	25	80					
MD5016RLF1L	431	25	79					
MD5016SAF1L	460	30	81	15'-10 ⁷ / ₈ "	10'-3 ³ / ₁₆ "	13933	8244	4358
MD5016SLF1L	459	30	80					
MD5016TAF1L	500	40	82					
MD5016TLF1L	493	40	80					

NOTE

- 1 Use this bulletin for preliminary layouts only. Obtain current drawings from your Marley sales representative. All table data is per cell.
- 2 Last two characters of the model number indicate number of cells and cell configuration.
- 3 Nominal tons are based upon 95°F HW, 85°F CW, 78°F WB and 3 GPM/ton. The Marley **UPDATE** web-based selection software provides MD model recommendations based on specific design requirements.
- 4 Standard overflow is a 3" dia. M connection located on the side of the collection basin. Makeup water connection is 2" dia. M connection located on the side of the tower. A 3" M drain connection is located on the side of the collection basin.

MD5016 TWO OR THREE CELL

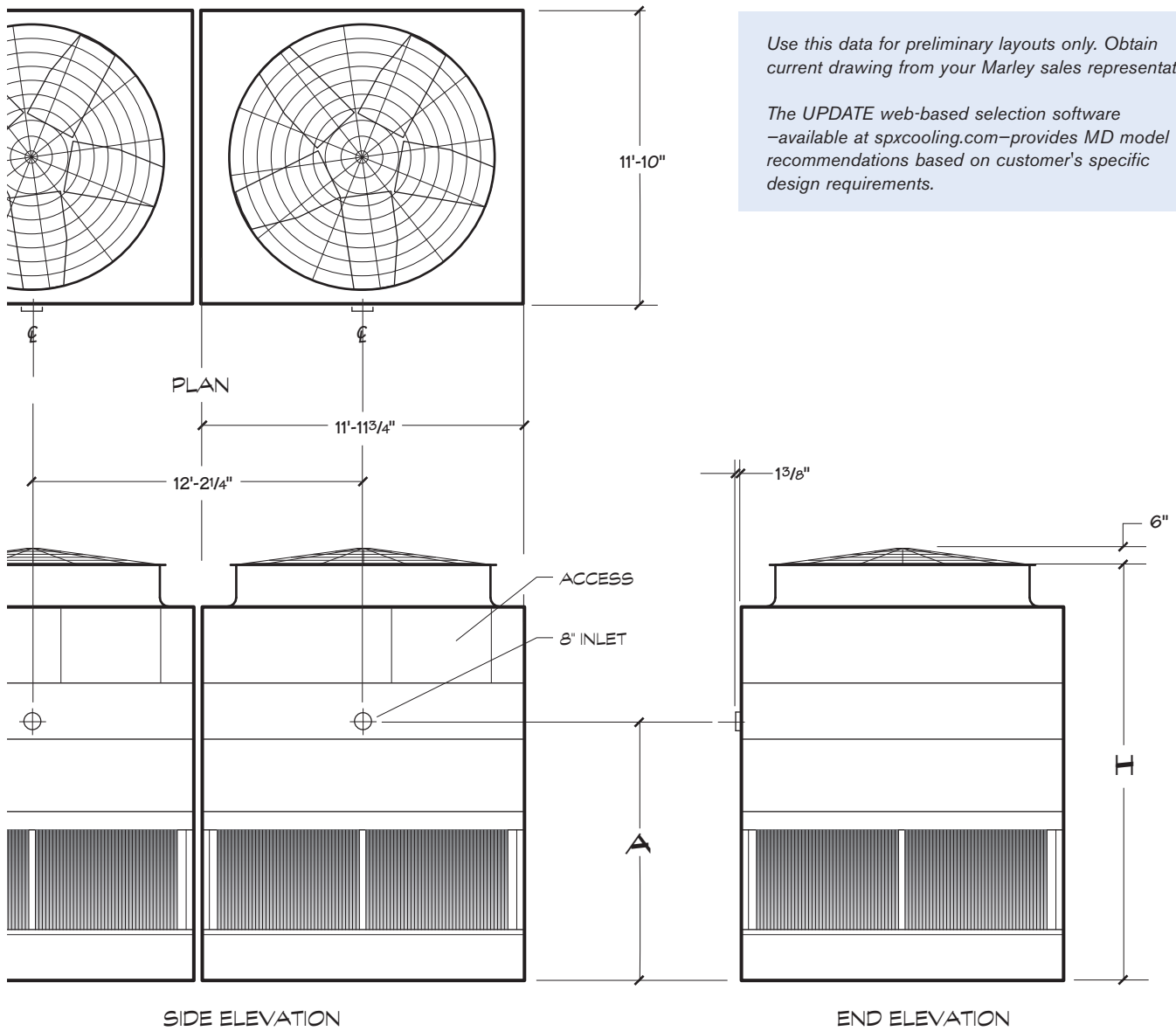

Use this data for preliminary layouts only. Obtain current drawing from your Marley sales representative.

The UPDATE web-based selection software –available at spxcooling.com–provides MD model recommendations based on customer's specific design requirements.

MD5016 TWO OR THREE CELL

Model note 2	Nominal Tons note 3	Motor hp	dBA 5'-0" from air inlet face	Dimensions		Design Operating Weight lb	Shipping Weight lb	
				H	A		Weight/Cell	Heaviest Section
MD5016PAC2L	317	15	79	14'-11"	9'-3 ¹ / ₈ "	12919	7230	3771
MD5016PLC2L	320	15	78					
MD5016QAC2L	345	20	80					
MD5016QLC2L	348	20	79					
MD5016RAC2L	369	25	80					
MD5016RLC2L	372	25	79					
MD5016SAC2L	390	30	81					
MD5016SLC2L	394	30	80					
MD5016PAD2L	350	15	79	15'-11"	10'-3 ¹ / ₈ "	13544	7855	3969
MD5016PLD2L	353	15	78					
MD5016QAD2L	383	20	80					
MD5016QLD2L	384	20	79					
MD5016RAD2L	410	25	80					
MD5016RLD2L	412	25	79					
MD5016SAD2L	436	30	81					
MD5016SLD2L	437	30	80					
MD5016TAD2L	475	40	82	16'-11"	13'-3 ¹ / ₈ "	14054	8365	4479
MD5016TLD2L	471	40	80					
MD5016PAF2L	368	15	79					
MD5016PLF2L	370	15	78					
MD5016QAF2L	403	20	80					
MD5016QLF2L	401	20	79					
MD5016RAF2L	431	25	80					
MD5016RLF2L	431	25	79					
MD5016SAF2L	460	30	81	16'-11"	13'-3 ¹ / ₈ "	14054	8365	4479
MD5016SLF2L	459	30	80					
MD5016TAF2L	500	40	82					
MD5016TLF2L	493	40	80					

NOTE

- 1 Use this bulletin for preliminary layouts only. Obtain current drawings from your Marley sales representative. All table data is per cell.
- 2 Last two characters of the model number indicate number of cells and cell configuration. Change as appropriate for your selection.
- 3 Nominal tons are based upon 95°F HW, 85°F CW, 78°F WB and 3 GPM/ton. The Marley **UPDATE** web-based selection software provides MD model recommendations based on specific design requirements.
- 4 Standard overflow is a 3" dia. M connection located on the side of the collection basin. Makeup water connection is 2" dia. M connection located on the side of the tower. A 3" M drain connection is located on the side of the collection basin.

MD5016 FOUR OR MORE CELLS

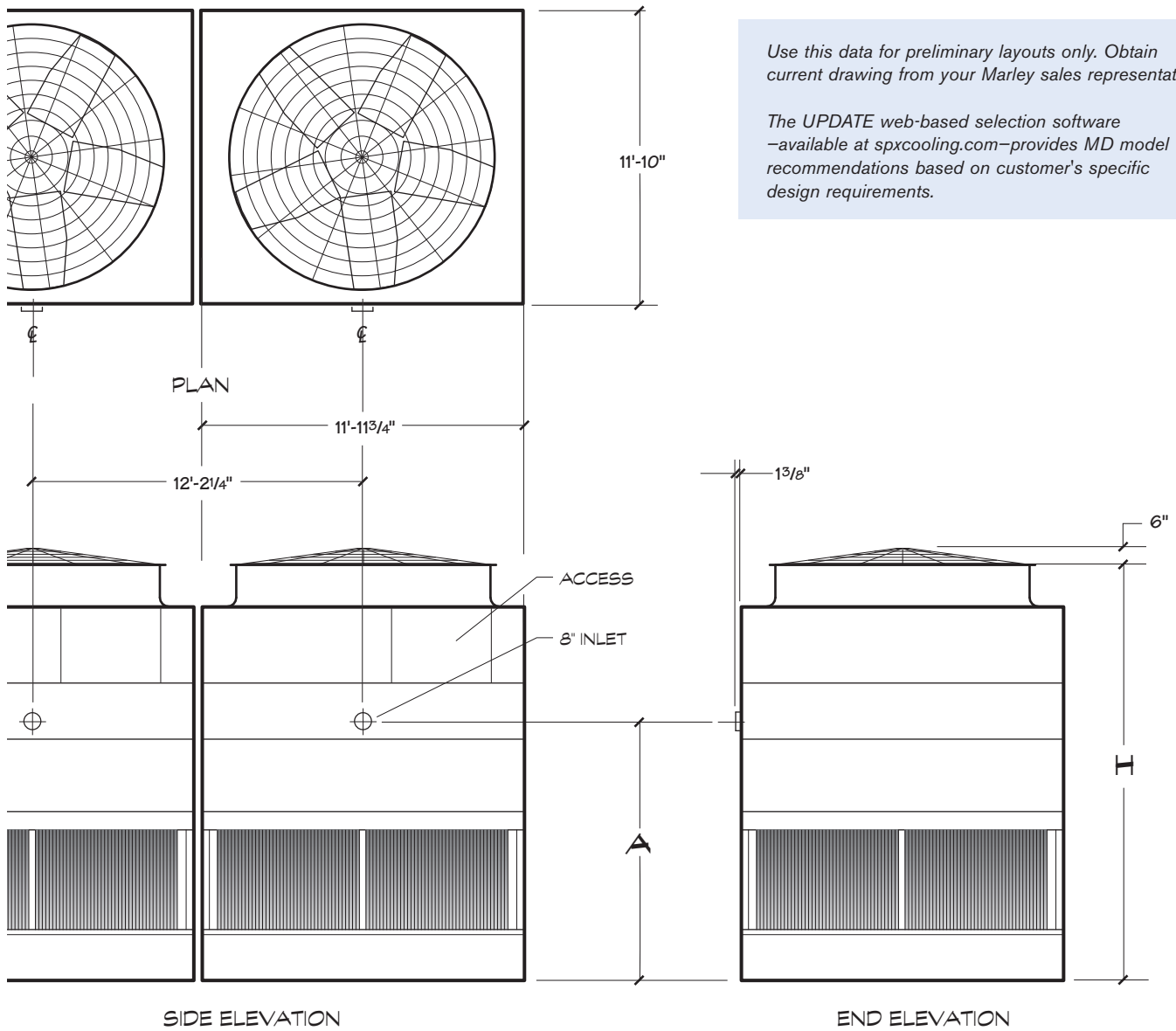

Use this data for preliminary layouts only. Obtain current drawing from your Marley sales representative.

The UPDATE web-based selection software –available at spxcooling.com–provides MD model recommendations based on customer's specific design requirements.

MD5016 FOUR OR MORE CELLS

Model note 2	Nominal Tons note 3	Motor hp	dBA 5'-0" from air inlet face	Dimensions		Design Operating Weight lb	Shipping Weight lb	
				H	A		Weight/Cell	Heaviest Section
MD5016PAC4L	317	15	79	15'-9"	10'-1 ¹ / ₈ "	13081	7392	3771
MD5016PLC4L	320	15	78					
MD5016QAC4L	345	20	80					
MD5016QLC4L	348	20	79					
MD5016RAC4L	369	25	80					
MD5016RLC4L	372	25	79					
MD5016SAC4L	390	30	81					
MD5016SLC4L	394	30	80					
MD5016PAD4L	350	15	79	16'-9"	11'-1 ¹ / ₈ "	13706	8017	4131
MD5016PLD4L	353	15	78					
MD5016QAD4L	383	20	80					
MD5016QLD4L	384	20	79					
MD5016RAD4L	410	25	80					
MD5016RLD4L	412	25	79					
MD5016SAD4L	436	30	81					
MD5016SLD4L	437	30	80					
MD5016TAD4L	475	40	82	17'-9"	12'-1 ¹ / ₈ "	14216	8527	4641
MD5016TLD4L	471	40	80					
MD5016PAF4L	368	15	79					
MD5016PLF4L	370	15	78					
MD5016QAF4L	403	20	80					
MD5016QLF4L	401	20	79					
MD5016RAF4L	431	25	80					
MD5016RLF4L	431	25	79					
MD5016SAF4L	460	30	81	17'-9"	12'-1 ¹ / ₈ "	14216	8527	4641
MD5016SLF4L	459	30	80					
MD5016TAF4L	500	40	82					
MD5016TLF4L	493	40	80					

NOTE

- 1 Use this bulletin for preliminary layouts only. Obtain current drawings from your Marley sales representative. All table data is per cell.
- 2 Last two characters of the model number indicate number of cells and cell configuration. Change as appropriate for your selection.
- 3 Nominal tons are based upon 95°F HW, 85°F CW, 78°F WB and 3 GPM/ton. The Marley **UPDATE** web-based selection software provides MD model recommendations based on specific design requirements.
- 4 Standard overflow is a 3" dia. M connection located on the side of the collection basin. Makeup water connection is 2" dia. M connection located on the side of the tower. A 3" M drain connection is located on the side of the collection basin.

MD5016 FOUR CELL QUAD

Use this data for preliminary layouts only. Obtain current drawing from your Marley sales representative.

The UPDATE web-based selection software –available at spxcooling.com–provides MD model recommendations based on customer's specific design requirements.

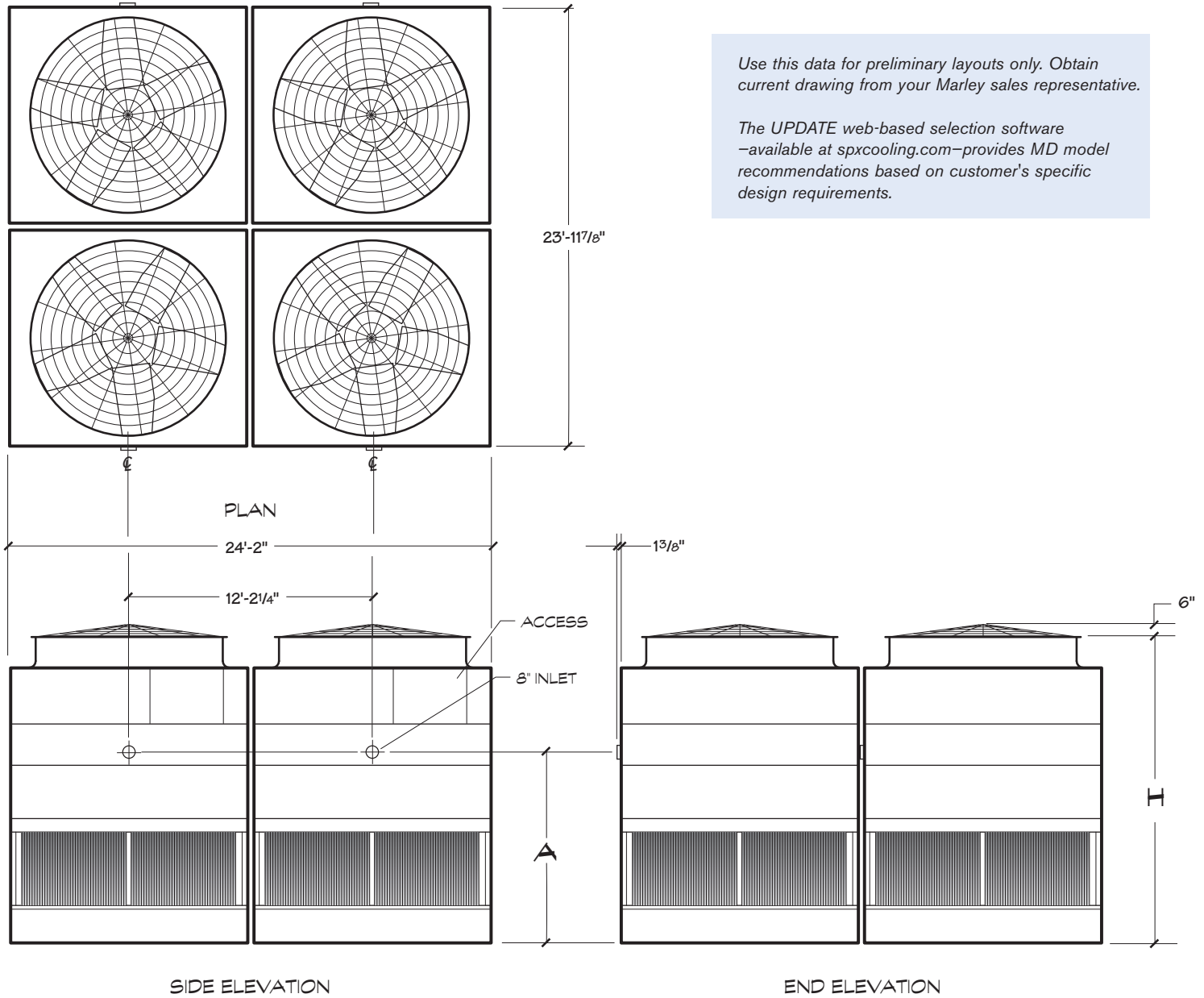

MD5016 FOUR CELL QUAD

Model note 2	Nominal Tons note 3	Motor hp	dBA 5'-0" from air inlet face	Dimensions		Design Operating Weight lb	Shipping Weight lb	
				H	A		Weight/Cell	Heaviest Section
MD5016PAC4B	317	15	79	15'-9"	10'-1 1/4"	13081	7392	3771
MD5016PLC4B	320	15	78					
MD5016QAC4B	345	20	80					
MD5016QLC4B	348	20	79					
MD5016RAC4B	369	25	80					
MD5016RLC4B	372	25	79					
MD5016SAC4B	390	30	81					
MD5016SLC4B	394	30	80					
MD5016PAD4B	350	15	79	16'-9"	11'-1 1/4"	13706	8017	4131
MD5016PLD4B	353	15	78					
MD5016QAD4B	383	20	80					
MD5016QLD4B	384	20	79					
MD5016RAD4B	410	25	80					
MD5016RLD4B	412	25	79					
MD5016SAD4B	436	30	81					
MD5016SLD4B	437	30	80					
MD5016TAD4B	475	40	82	17'-9"	12'-1 1/4"	14216	8527	4641
MD5016TLD4B	471	40	80					
MD5016PAF4B	368	15	79					
MD5016PLF4B	370	15	78					
MD5016QAF4B	403	20	80					
MD5016QLF4B	401	20	79					
MD5016RAF4B	431	25	80					
MD5016RLF4B	431	25	79					
MD5016SAF4B	460	30	81	17'-9"	12'-1 1/4"	14216	8527	4641
MD5016SLF4B	459	30	80					
MD5016TAF4B	500	40	82					
MD5016TLF4B	493	40	80					

NOTE

- 1 Use this bulletin for preliminary layouts only. Obtain current drawings from your Marley sales representative. All table data is per cell.
- 2 Nominal tons are based upon 95°F HW, 85°F CW, 78°F WB and 3 GPM/ton. The Marley **UPDATE** web-based selection software provides MD model recommendations based on specific design requirements.

- 3 Standard overflow is a 3" dia. M connection located on the side of the collection basin. Makeup water connection is 2" dia. M connection located on the side of the tower. A 3" M drain connection is located on the side of the collection basin.

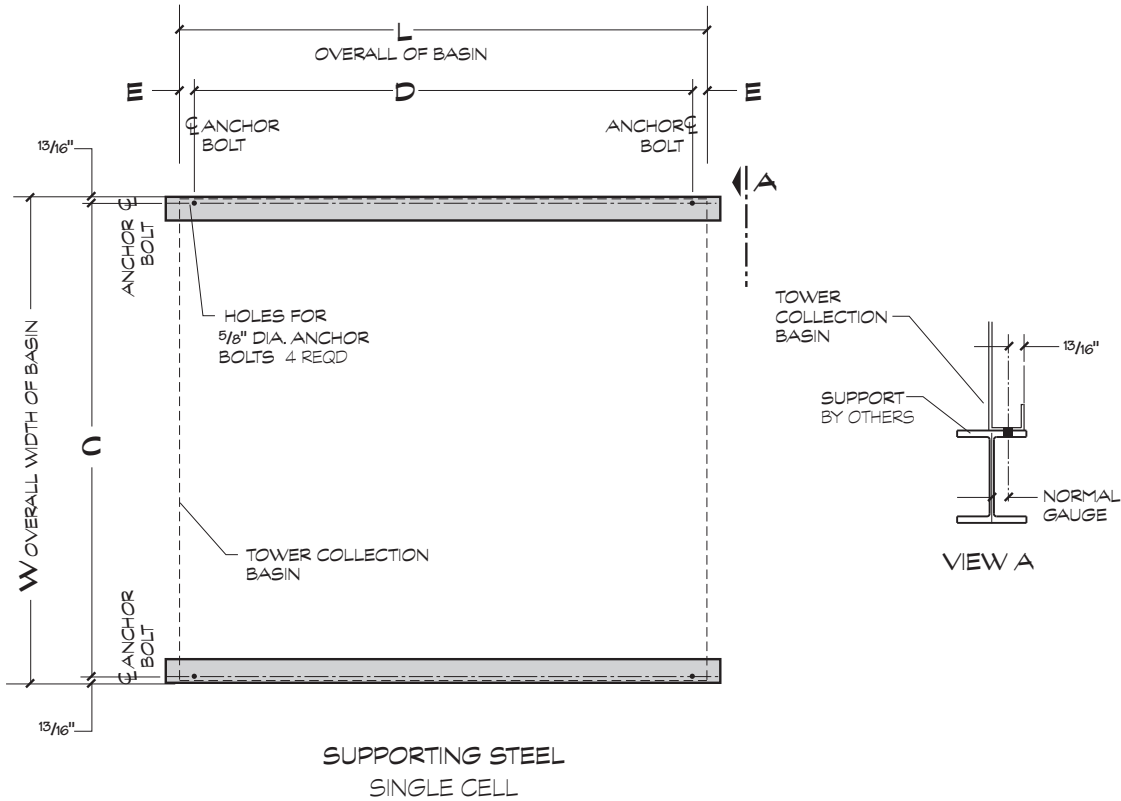

Model	Dimensions						Design Operating Weight per cell lb	Design Operating Load at support beam lb/ft
	W	L	C	D	E	F		
MD5008_C	8'-5½"	8'-11½"	8'-3¾"	8'-7½"	2"	6½"	6772	378
MD5008_D	8'-5½"	8'-11½"	8'-3¾"	8'-7½"	2"	6½"	7049	394
MD5008_F	8'-5½"	8'-11½"	8'-3¾"	8'-7½"	2"	6½"	7326	409
MD5010_C	8'-5½"	11'-11¼"	8'-3¾"	11'-7¾"	2"	6½"	8611	369
MD5010_D	8'-5½"	11'-11¼"	8'-3¾"	11'-7¾"	2"	6½"	8970	382
MD5010_F	8'-5½"	11'-11¼"	8'-3¾"	11'-7¾"	2"	6½"	9384	398
MD5016_C	11'-10"	11'-11¼"	11'-8¾"	11'-1¼"	5"	12½"	12919	610
MD5016_D	11'-10"	11'-11¼"	11'-8¾"	11'-1¼"	5"	12½"	13544	639
MD5016_F	11'-10"	11'-11¼"	11'-8¾"	11'-1¼"	5"	12½"	14054	660

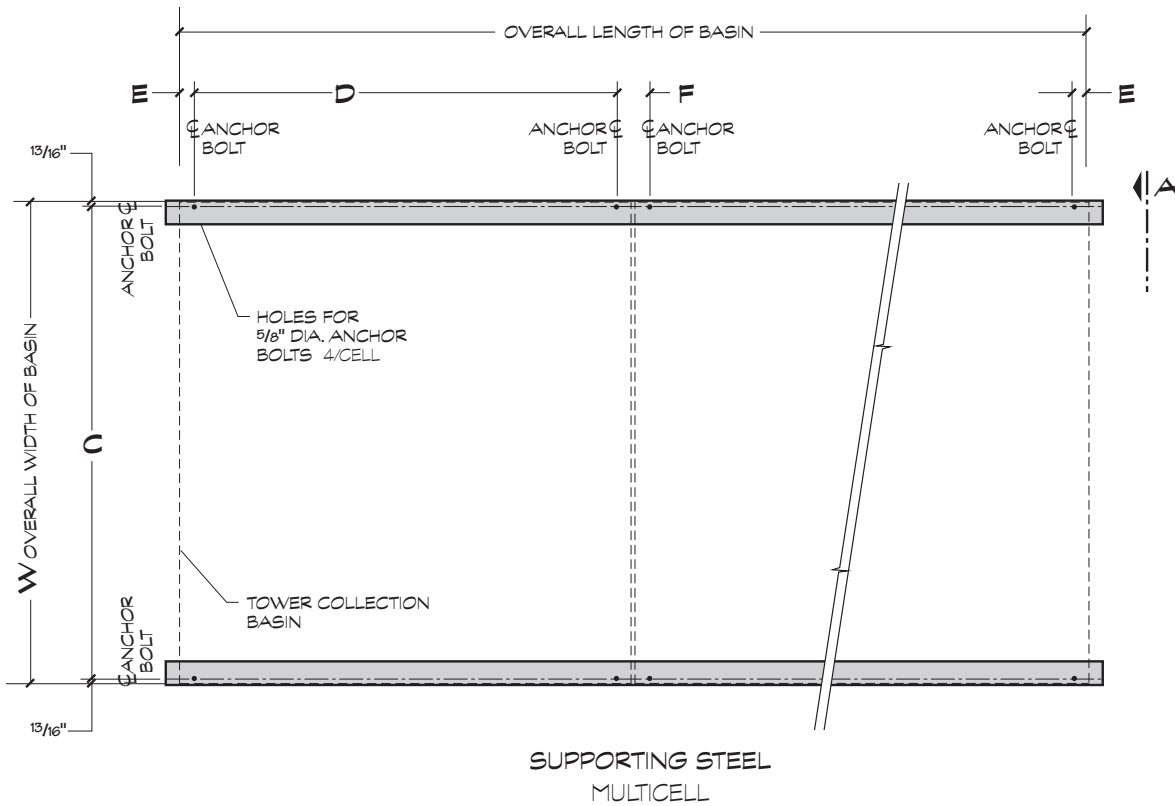

SUPPORTING STEEL
MULTICELL

NOTE

- 1 Use this bulletin for preliminary layouts only. Obtain current drawings from your Marley sales representative for final design.
- 2 Purchaser to provide tower support complete with holes and anchor bolts. Do not use studs! Anchor points must be framed flush and level at top.
- 3 Design operating weight occurs with collection basin full to overflow level. Actual operating weight varies with GPM and piping scheme.
- 4 Tower may be placed on a flat concrete slab. Side outlet and optional side drain and overflow must be specified.

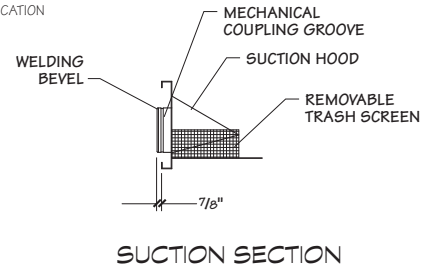
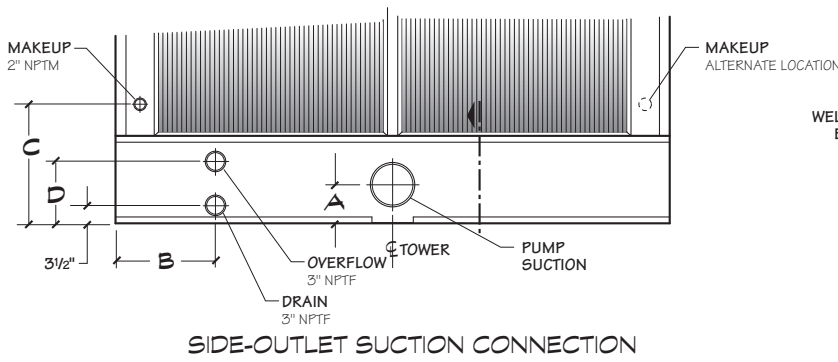

SIDE-OUTLET SUCTION CONNECTION

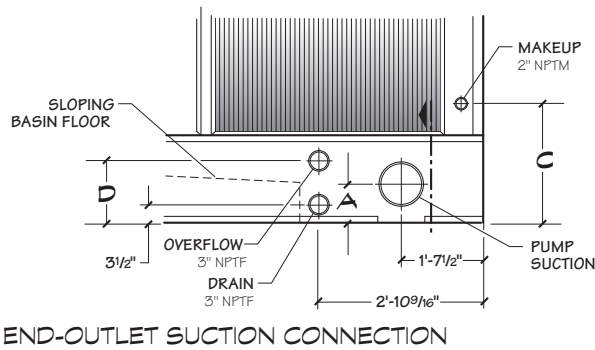

Model	Dimensions				
	Suction Diameter	A	B	C	D
MD5008	6"	-	1'-7 3/8"	1'-11 1/8"	1'-0"
	8"	7 1/2"	1'-7 3/8"	1'-11 1/8"	1'-0"
	10"	-	1'-7 3/8"	1'-11 1/8"	1'-0"
MD5010	6"	-	1'-6 3/4"	1'-11 1/8"	1'-0"
	8"	7 1/2"	1'-6 3/4"	1'-11 1/8"	1'-0"
	10"	-	1'-6 3/4"	1'-11 1/8"	1'-0"
MD5016	6"	-	1'-6 3/4"	2'-1 1/8"	1'-1"
	8"	7 1/2"	1'-6 3/4"	2'-1 1/8"	1'-1"
	10"	8 1/2"	1'-6 3/4"	2'-1 1/8"	1'-1"
	12"	-	1'-6 3/4"	2'-1 1/8"	1'-1"

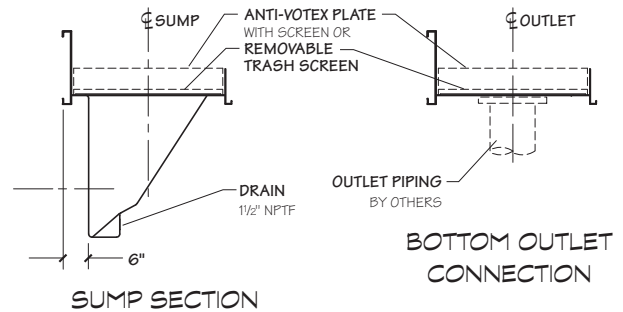
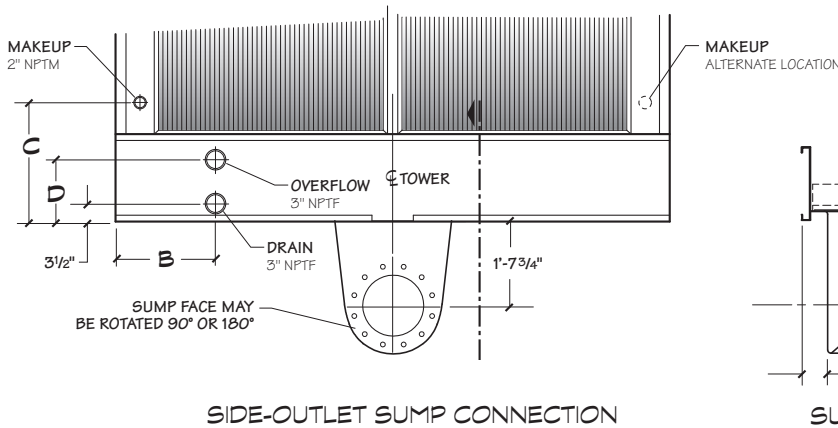

Outlet Diameter	Maximum GPM per Outlet														
	Side or End Suction pump flow			Sump pump flow without anti-vortex plate			Sump pump flow with anti-vortex plate or gravity flow with or without anti-vortex plate			Bottom Outlet pump flow without anti-vortex plate			Bottom Outlet pump flow with anti-vortex plate or gravity flow with or without anti-vortex plate		
	MD5008	MD5010	MD5016	MD5008	MD5010	MD5016	MD5008	MD5010	MD5016	MD5008	MD5010	MD5016	MD5008	MD5010	MD5016
6"				630	630	630	900	900	900				345		
8"	1138	1485	1559	1091	1091	1091	1138	1485	1559				598	598	598
10"			2167	1138	1485	1720	1138	1485	2167	422	442		943	943	943
12"						2167			2167	625	628	628	1138	1338	1338
14"										760	760	760	1138	1485	1618
16"										991	991	991	1138	1485	2112
18"										1138	1256	1259	1138	1485	2167
20"											1485	1559		1485	2167
24"												2167			2167

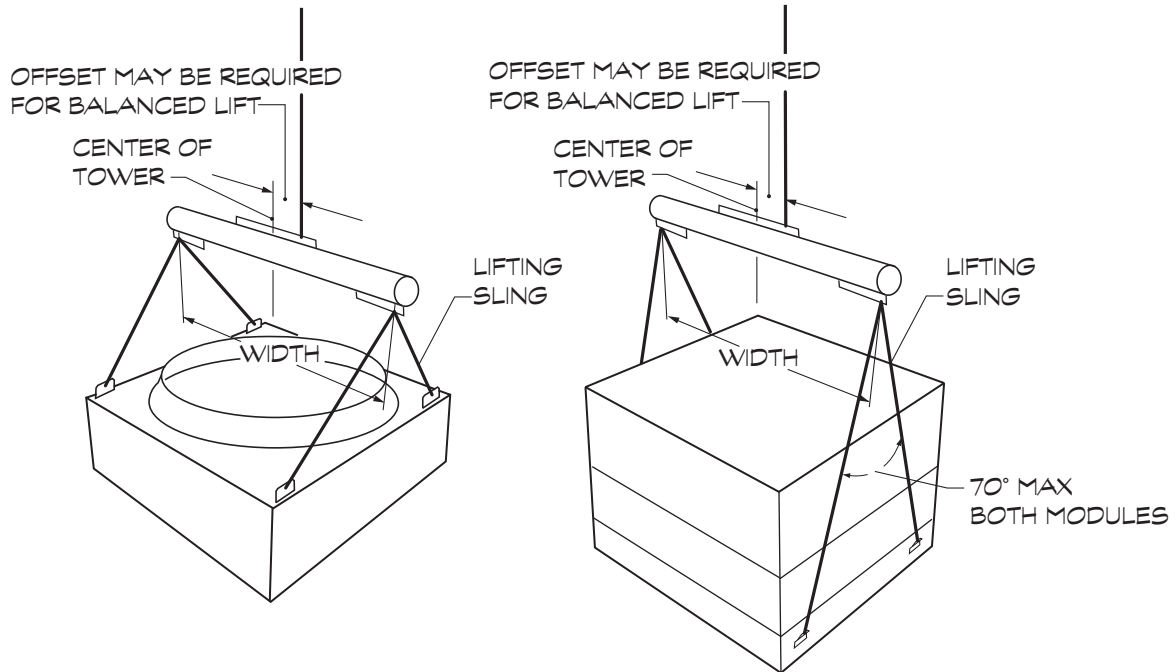

Model	Base Module			Top Module		
	Width	Sling Length Minimum	Weight lb	Width	Sling Length Minimum	Weight lb
MD5008	8'-6"	10'-0"	2400	9'-0"	8'-0"	2000
MD5010	8'-6"	12'-0"	3000	8'-6"	10'-0"	2300
MD5016	12'-0"	12'-0"	3600	12'-0"	10'-0"	3800

NOTE

- 1 Hoisting operations can be dangerous and suitable safety precautions should be taken to protect personnel and the equipment being hoisted.
- 2 All hoisting equipment should be certified and comply with local and national safety regulations.
- 3 Ensure that slings are of sufficient length so not to impose bending loads onto the casing—use of spreader bars is essential.
- 4 For overhead lifts or where additional safety is required, add slings beneath the tower unit

When the ambient air temperature falls below 32°F, the water in a cooling tower can freeze. *Marley Technical Report #H-003 “Operating Cooling Towers in Freezing Weather”* describes how to prevent freezing during operation. Available at spxcooling.com or ask your Marley sales representative for a copy.

During shutdown, water collects in the cold water basin and may freeze solid. You can prevent freezing by adding heat to the water left in the tower—or, you can drain the tower and all exposed pipework at shutdown.

Electric Basin Heaters

An automatic basin water heater system is available consisting of the following components:

- Stainless steel electric immersion heater(s).
 - Threaded couplings are provided in the side of the collection basin.
- NEMA 4 enclosure containing:
 - Magnetic contactor to energize heater.
 - Transformer to convert power supply to 24 volts for control circuit.
 - Solid state circuit board for temperature and low-water cutoff.Enclosure may be mounted on the side of the tower.
- Control probe in the collection basin to monitor water temperature and level.

Heater components are normally shipped separately for installation by others.

Note: any exposed piping that is still filled with water at shutdown—including the makeup water line—should be electrically traced and insulated (by others).

Indoor Storage Tank

With this type of system, water flows from an indoor tank, through the load system, and back to the tower, where it is cooled. The cooled water flows by gravity from the tower to the tank located in a heated space. At shutdown, all exposed water drains into the tank, where it is safe from freezing.

The amount of water needed to successfully operate the system depends on the tower size and GPM and on the volume of water contained in the piping system to and from the tower. You must select a tank large enough to contain those combined volumes—plus a level sufficient to maintain a flooded suction on your pump. Control makeup water according to the level where the tank stabilizes during operation.

The MD cooling tower can be a very effective air washer. Atmospheric dust able to pass through the relatively small louver openings will enter the recirculating water system. Increased concentrations can intensify systems maintenance by clogging screens and strainers—and smaller particulates can coat system heat transfer surfaces. In areas of low flow velocity—such as the collection basin—sedimentary deposits can provide a breeding ground for bacteria.

In areas prone to dust and sedimentation, you should consider installing some means for keeping the collection basin clean. Typical devices include side stream filters and a variety of filtration media.

Blowdown

Blowdown or Bleedoff is the continuous removal of a small portion of the water from the open recirculating system. Blowdown is used to prevent the dissolved solids from concentrating to the point where they will form scale. The amount of blowdown required depends on the cooling range—the difference between the hot and cold water temperatures of the closed circuit— and the composition of the makeup water.

⚠ CAUTION

The MD cooling tower must be located at such distance and direction to avoid the possibility of contaminated discharge air being drawn into building fresh air intake ducts. The purchaser should obtain the services of a Licensed professional Engineer or Registered Architect to certify that the location of the cooling tower is in compliance with applicable air pollution, fire and clean air codes.

Water Treatment

To control the buildup of dissolved solids resulting from water evaporation, as well as airborne impurities and biological contaminants including Legionella, an effective consistent water treatment program is required. Simple blowdown may be adequate to control corrosion and scale, but biological contamination can only be controlled with biocides.

An acceptable water treatment program must be compatible with the variety of materials incorporated in a cooling tower—ideally the pH of the recirculating water should fall between 6.5 and 9.0. Batch feeding of the chemicals directly into the cooling tower is not a good practice since localized damage to the cooling tower is possible. Specific startup instructions and additional water quality recommendations can be found in the *MD Cooling Tower User Manual* which accompanies the cooling tower and also is available at spxcooling.com.

Specifications	Specification Value
<p>1.0 Base:</p> <p>1.1 Furnish and install an induced-draft, counterflow-type, factory assembled, film fill, industrial duty, cooling tower. Unit shall consist of ____ cell(s), as shown on plans. The limiting overall dimensions of the tower shall be ____ wide, ____ long, and ____ high. Total operating power of all fans shall not exceed ____ hp, consisting of ____ @ ____ hp motor(s). Tower shall be Marley Model _____.</p> <p>2.0 Thermal Performance:</p> <p>2.1 The tower shall be capable of cooling ____ GPM of water from ____ °F to ____ °F at a design entering air wet-bulb temperature of ____ °F. The thermal performance rating shall be Certified by the Cooling Technology Institute. Tower shall comply with all ASHRAE 90.1 standards.</p> <p>3.0 Performance Warranty:</p> <p>3.1 CTI Certification notwithstanding, the cooling tower manufacturer shall guarantee that the cooling tower supplied will meet the specified performance conditions when the tower is installed as shown on the plans. If, because of a suspected thermal performance deficiency, the owner chooses to conduct an on-site thermal performance test under the supervision of a qualified, disinterested third party in accordance with CTI, ASME or other applicable standards during the first year of operation; and if the tower fails to perform within the limits of test tolerance; then the cooling tower manufacturer will pay for the cost of the test and will make such corrections as are appropriate and agreeable to the owner to compensate for the performance deficiency.</p>	<p>■ Your specification base establishes the type, configuration, base material, and physical limitations of the cooling tower to be quoted. During the planning and layout stages of your project, you will have focused your attention on a cooling tower selection that fits your space allotment, and whose power usage is acceptable. Limitations on physical size and total operating horsepower avoid the introduction of unforeseen operational and site-related influences. Specifying the number of cells, and the maximum fan hp/cell will work to your advantage.</p> <p>You are specifying a counterflow tower, which is a type noted—and usually specified—for its economical use of plan area on projects where the required thermal performance is very difficult. It effectively replaces most makes of older towers—both forced-draft and induced-draft—without major redesign of the existing site.</p> <p>■ CTI Certification means that the cooling tower has been tested under operating conditions and found to perform as rated by the manufacturer under those circumstances. It assures the buyer that the tower is not intentionally or inadvertently undersized by the manufacturer.</p> <div style="text-align: right;">  </div> <p>■ However, CTI certification alone is not sufficient to assure you that the cooling tower will perform satisfactorily in your situation. Certification is established under relatively controlled conditions, and cooling towers seldom operate under such ideal circumstances. They are affected by nearby structures, machinery, enclosures, effluent from other sources, etc. Responsible and knowledgeable bidders will take such site-specific effects into consideration in selecting the cooling tower—but the specifier must insist by the written specification that the designer/manufacturer guarantee this “real world” performance. Any reluctance on the part of the bidder should cause you some concern.</p>

Specifications	Specification Value
<p>4.0 Design Loading:</p> <p>4.1 The tower and its components shall be designed to withstand a wind load of 20 psf. The cooling tower shall be de-signed to withstand shipping and hoisting loads of 2g horizontal or 3g vertical. Guardrails, where specified shall be capable of with-standing a 200 lb concentrated live load in any direction and shall be designed in accordance with OSHA guidelines.</p> <p>5.0 Construction:</p> <p>5.1 Except where otherwise specified, all components of the cooling tower shall be fabricated of heavy-gauge steel, pro- tected against corrosion by G-235 galva- nizing. After passivation of the galvanized steel (8 weeks at pH 7-8, and calcium hardness and alkalinity at 100-300 ppm each), the cooling tower shall be capable of withstanding water having a pH of 6.5 to 9.0; a chloride content up to 500 ppm as NaCl (300 ppm as Cl-); a sulfate con- tent (as SO4) up to 250 ppm; a calcium content (as CaCO3) up to 500 ppm; silica (as SiO2) up to 150 ppm; and design operating ranges up to 50°F. The circulat- ing water shall contain no oil, grease, fatty acids, or organic solvents.</p> <p>5.2 The specifications, as written, are intend- ed to indicate those materials that will be capable of withstanding the above water quality in continuing service, as well as the loads described in paragraph 4.1. They are to be regarded as minimum requirements. Where component materials unique to individual tower designs are not specified, the manufacturers shall take the above water quality and load carrying capabilities into account in the selection of their materials of manufacture.</p> <p>6.0 Mechanical Equipment:</p> <p>6.1 Fan(s) shall be propeller-type, incorpo- rating heavy aluminum alloy blades and electrogalvanized hubs. Blades shall be individually adjustable and both statically and dynamically balanced. Fan(s) shall be driven through a one-piece multi-groove, solid back V-type belt, sheaves (pulleys), and tapered roller bearings. Bearings shall be rated at an L₁₀ life of 100,000</p>	<p>■ The indicated design values are the minimum allowables under accepted design standards. They give you assurance that the cooling tower can be shipped, han- dled, hoisted—and ultimately operated in a normal cooling tower environment. Most MD models will withstand significantly higher wind and seismic loads. If your geographic location dictates higher wind load or seismic load values, please make the appropriate changes, after discussion with your Marley sales representative.</p> <p>■ In the history of cooling towers, no other coating for carbon steel has exhibited the success and longevity of galvanization in exposure to the normal cooling tower water quality defined at left. No paints or electrostatically-applied coat- ings, however exotic they may be, can approach galvanization's history of suc- cess.</p> <p>If extended longevity of the cooling tower is required—or unusually harsh operat- ing conditions are expected—consider specifying stainless steel as either the base construction material, or the material utilized for specific components of your choice. See Stainless Steel Options on page 16.</p> <div style="text-align: center;">  </div> <p>■ Propeller-type fans require only half the operating hp of blower-type fans. However, they should be readily adjustable to permit compensation for jobsite conditions. The fans of one manufacturer require the purchase of special posi- tioners for each increment of fan blade pitch.</p> <p>The Marley Power Belt drive system features all-aluminum sheaves, power band belts and long-life bearings for dependable service.</p>



Specifications	Specification Value
<p>hours, or greater. Both motor and fan sheaves (pulleys) shall be all cast aluminum to prevent premature corrosion.</p> <p>6.2 Motor(s) shall be ____ hp maximum, TEFC, 1.15 service factor, variable torque, inverter duty and specially insulated for cooling tower duty. Speed and electrical characteristics shall be ____ RPM, single-winding, ____ phase, ____ hertz, ____ volts. Motor nameplate power shall not be exceeded at design operation. TEAO motors are not acceptable.</p> <p>6.3 The complete mechanical equipment assembly for each cell shall be supported by a rigid, hot-dip galvanized steel structural support that resists misalignment between the motor and sheaves (pulleys). For belt-drive towers with motors inside the airstream, motors shall be mounted on an adjustable base that swivels outside the access door for maintenance. For belt-drive towers with motors mounted outside the airstream, a protective cover shall be mounted over the motor and sheave to protect it from the weather and prevent inadvertent contact. The mechanical equipment assembly shall be warranted against any failure caused by defects in materials and workmanship for no less than five (5) years following the date of tower shipment. This warranty shall cover the fan, speed reducer, drive shaft and couplings, and the mechanical equipment support. The electric motor shall carry a manufacturer's warranty of at least one year. The bearing assemblies and V-belts shall be warranted for 18 months.</p>	<p>TEFC motors offer additional benefits over TEAO motors whose only source of cooling is the flow of air produced by the cooling tower fan. This air rate is not always ideal due to motor position, blockage, etc. TEFC ensures the motor will always be cooled properly.</p> <p>Unless otherwise specified, motor speed will be 1800 RPM on standard models. Low noise models will use motor speeds appropriate for the specific model. If you prefer the operating flexibility of two-speed operation, please specify two-speed, single-winding motors which offer full and half speeds for maximum energy savings. Incidentally, two speed motors are a far better choice than separate "pony" motors which simply double the problems indicated above and induce parasitic loads during operation for lower than nameplate efficiency.</p> <p>The value of a 5 year mechanical equipment warranty speaks for itself. Except for the motor, virtually all of the mechanical equipment on a Marley tower is designed and manufactured by SPX Cooling Technologies. Cooling tower vendors who purchase commercial fans, driveshafts, etc. may require that you deal directly with those commercial suppliers for warranty satisfaction.</p>



Specifications

Specification Value

7.0 Fill, Louvers and Drift Eliminators:

7.1 Fill shall be cross-corrugated, counterflow film type, thermoformed from 15 mil thick PVC. Fill shall be assembled into packs for ease of removal and cleaning. Fill shall be supported on channel sections supported from the tower structure and have a flame spread rating less than 25. Drift eliminators shall be PVC with a minimum of three changes in air direction, and shall limit drift losses to 0.005% or less of the design water flow rate.

7.2 Air inlet louvers shall be a minimum of 5" air travel, triple pass PVC to prevent water splashout and eliminate sunlight from entering the collection basin. For ease of service and long life of louvers, PVC louvers shall be enclosed in a removable frame that attaches to the air inlet without tools. Louvers with less than three changes in air direction are unacceptable.

8.0 Hot Water Distribution System:

8.1 A pressured spray system shall distribute water evenly over the fill. The branch arms shall be corrosion resistant PVC with polypropylene spray nozzles attached to the branch arms with a rubber socket connection for ease of removal and cleaning. To ensure proper spray system operation, nozzles shall seat in branch arms without regard for direction or alignment.

9.0 Casing and Fan Guard:

9.1 The casing shall be heavy gauge G-235 galvanized steel and shall be capable of withstanding the loads described in paragraph 4.1. Casing panels shall encase the fill on all four sides of the tower. The top of the fan cylinder shall be equipped with a conical, non-sagging, removable fan guard, fabricated of welded 5/16" and 7 gauge rods, and hot dip galvanized after fabrication.

- Fill modules can be removed for inspection and cleaning in accordance with local anti legionella guidelines.

Drift rate varies with design water loading and air rate, as well as drift eliminator depth and number of directional changes. A drift rate of 0.001% is readily available on many standard models. If a lower rate is required, please discuss with your Marley sales representative.



- The combination of PVC piping and polypropylene nozzles is very resistant to the build-up of scale and slime.

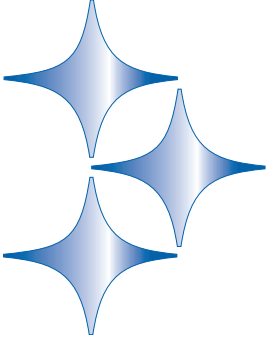

Specifications	Specification Value
<p>10.0 Access:</p> <p>10.1 A large rectangular access door shall be located in the plenum on the motor side of the tower.</p> <p>11.0 Cold Water Collection Basin:</p> <p>11.1 The collection basin shall be heavy-gauge galvanized steel and shall include the number and type of suction connections required to accommodate the out-flow piping system shown on the plans. Suction connections shall be equipped with debris screens. A factory installed, float operated, mechanical make-up valve shall be included. An overflow and drain connection shall be provided in each cell of the tower. The basin floor shall slope toward the drain to allow complete flush out of debris and silt which may accumulate. Towers of more than one cell shall include steel flumes for flow and equalization between cells.</p> <p>13.0 Warranty:</p> <p>13.1 The MD cooling tower shall be free from defects in materials and workmanship for a period of eighteen (18) months from the date of shipment.</p>	<p>■ The MD tower design offers side-suction as standard. Bottom outlets may be supplied to accommodate a variety of piping schemes. Unless so specified, the tower you may be asked to approve may only be available with one type of suction connection requiring you to redesign your piping layout.</p> <p>The sloping floor and low-level drain is valuable because it provides a way to achieve flush-out cleanability.</p>

Specifications	Specification Value
<p>Stainless Steel Options</p>	
<p>Stainless Steel Collection Basin:</p>	
<p>11.1 <i>Replace paragraph 11.1 with the following:</i> The collection basin shall be heavy-gauge Series 300 stainless steel. Only low-carbon stainless steel alloys will be accepted in order to minimize the risk of intergranular corrosion in the weld zones. Basin shall include the number and type of suction connections required to accommodate the out-flow piping system shown on the plans. Basin suction connections shall be equipped with debris screens. A factory installed, float operated, mechanical make-up valve shall be included. An overflow and drain connection shall be provided in each cell of the tower. The basin floor shall slope toward the drain to allow complete flush out of debris and silt which may accumulate.</p>	<ul style="list-style-type: none"> ■ The cold water basin is the only part of the tower that is subject to periods of stagnant water, concentrated with treatment chemicals and customary contaminants. It is also the most expensive and difficult part of any tower to repair or replace. For these reasons, many customers—particularly those who are replacing older towers—choose to specify stainless steel cold water basins.
	
<p>5.1 <i>Replace paragraph 5.1 with the following:</i> Except where otherwise specified, all components of the cooling tower shall be fabricated of heavy-gauge, series 300 stainless steel. Only low-carbon stainless steel alloys will be accepted in order to minimize the risk of intergranular corrosion in the weld zones. The tower shall be capable of withstanding water having a chloride content (NaCl) up to 750 ppm; a sulfate content (SO4) up to 1200 ppm; a calcium content (CaCO3) up to 800 ppm; silica (SiO2) up to 150 ppm; and design operating ranges up to 50°F (27.78OC). The circulating water shall contain no oil, grease, fatty acids, or organic solvents.</p>	<ul style="list-style-type: none"> ■ For pure resistance to corrosion—coupled with the capability to meet stringent fire and building codes—there is no substitute for stainless steel. No paints or electrostatically-applied coatings, however exotic they may be, can match stainless steel's ability to withstand adverse operating conditions.

Specifications	Specification Value
<p>Convenience and Safety Options</p>	
<p>Mechanical Access Platform:</p>	
<p><u>10.2</u> Add the following paragraph in the Access section: There shall be a mechanical access platform at the mechanical access door allowing access to the mechanical system, drift eliminators, distribution system and fill. The platform shall be galvanized steel bar grating, supported by galvanized steel framework attached to the tower. The platform shall be surrounded by a guardrail, kneerail, and toeboard designed according to meet local safety requirements. A ladder shall be permanently attached to the platform and to the casing of the tower, rising from the base of the tower to the top of the handrail.</p>	<ul style="list-style-type: none"> ■ Periodic inspection and maintenance of a cooling tower distribution system is fundamental to preserving maximum cooling system efficiency. All cooling towers—crossflow or counterflow—are subject to clogging to varying degrees by waterborne contaminants such as pipe scale and sediment. Therefore, safe and easy access to these components is of significant value to the operator. <p>Access can be provided in a number of ways, including portable ladders or scaffolding, but for maximum safety and convenience, a field installed Marley access platform with guardrails is available to make this task as safe and user-friendly as possible. Further, its location on the side of the tower does not add to the height of the unit, preserving architectural integrity. It also saves the owner time and money, in that maintenance personnel may devote their time to inspection rather than searching for ladders or erection of portable scaffolding.</p>
<p>Ladder Extension:</p>	
<p><u>10.2</u> Add the following to the end of paragraph 10.2: Provide a ladder extension for connection to the foot of the ladder. This extension shall be long enough to rise from the roof (grade) level to the base of the cooling tower. The installing contractor shall be responsible for cutting the ladder to length; attaching it to the foot of the cooling tower ladder; and anchoring it at its base.</p>	<ul style="list-style-type: none"> ■ Many cooling towers are installed such that the base of the unit is 2'-0" or more above the roof or grade level. This makes it difficult to get up to the foot of the attached ladder. The ladder extension alleviates this problem. Marley ladder extensions are available in standard 5'-0" and 11'-0" lengths.
<p>Ladder Safety Cage:</p>	
<p><u>10.3</u> Add the following paragraph in the Access section: A welded aluminum safety cage shall surround the ladder, extending from a point approximately 7'-0" above the foot of the ladder to the top of the handrail.</p>	
<p>Motor Davit:</p>	
<p><u>10.4</u> Add the following paragraph in the Access section: A powder coated davit crane with hot dipped galvanized mounting base shall be field installed on the motor face of the cooling tower and shall have a maximum capacity of 500 lbs that may be moved to other cells when each cell is modified with a mounting base to accept the davit.</p>	<ul style="list-style-type: none"> ■ Simplify the removal of the fan motor when required. <p>If you would prefer stainless steel construction change powder coated and hot dipped galvanized to stainless steel in the description. Available with this option is a zinc plated hand crank winch with 45'-0 of 3/16" diameter galvanized aircraft cable with swivel hook with swaged ball fitting.</p>

Specifications

Motor and Fan Davit:

10.4 Add the following paragraph in the *Access section*: A powder coated davit crane with hot dipped galvanized mounting base shall be field installed on the motor face of the cooling tower. The davit shall have maximum capacity of 500 lbs at a 5'-6" boom extension and 1000 lbs at a 3'-0" boom extension. The davit may be moved to other cells when each cell is modified with a mounting base to accept the davit.

Control Options

Fan Motor Starter Control Panel:

6.4 Add the following paragraph in the *Mechanical Equipment section*: Each cell of the cooling tower shall be equipped with a UL / CUL 508 listed control panel in a NEMA 3R or 4X outdoor enclosure capable of controlling single-speed or two-speed motors as required, and designed specifically for cooling tower applications. The panel shall include a main circuit breaker or main fused disconnect with an external operating handle, lockable in the off position for safety. Full voltage non-reversing magnetic starter shall be controlled with a thermostatic or solid-state temperature controller. Door mounted selector switches shall be provided to enable automatic or manual control and wired for 120VAC control. Control circuit to be wired out to terminal blocks for field connection to a remote vibration switch, overload trip alarms and remote temperature control devices. The temperature controller shall be adjustable for the required cold-water temperature. If a thermostatic controller is used it shall be mounted on the side of the tower with the temperature sensing bulb installed in the cold water basin using a suspension mounting bracket. If a solid-state temperature controller is used the controller will be door mounted on the control panel. The solid-state temperature controller will display two temperatures, one for outgoing water and the other for set point. Water temperature input shall be obtained using a three-wire RTD with dry well in the outlet water piping and wired back to the solid-state temperature controller in the control panel.

Specification Value

- Simplify the removal of the fan motor or fan assemble when required. If you would prefer stainless steel construction change powder coated and hot dipped galvanized to stainless steel in the description. Available with this option is a zinc plated hand crank winch with 60'-0" of 1/4" diameter galvanized aircraft cable with swivel hook and swaged ball fitting.

Also available with this options is a 115V electric winch with a 6'-0" pendant control. Includes 60'-0" of 1/4" diameter galvanized aircraft cable with swivel hook with swaged ball fitting.

- If it is your opinion that the control system for the cooling tower be part of the cooling tower manufacturer's responsibility, we are in wholehearted agreement with you. Who better to determine the most efficient mode and manner of a cooling tower's operation—and to apply a system most compatible with it—than the designer and manufacturer of the cooling tower?

Marley variable speed drives are also available for the ultimate in temperature control, energy management, and mechanical equipment longevity.



Specifications

Specification Value

Vibration Limit Switch:

6.5 *Add the following paragraph in the Mechanical Equipment section:* A single-pole, double-throw vibration limit switch in a NEMA 4 housing shall be installed on the mechanical equipment support for wiring into the owner's control panel. The purpose of this switch will be to interrupt power to the motor in the event of excessive vibration. It shall be adjustable for sensitivity, and shall require manual reset.

■ Unless specified otherwise, a Marley M-5 vibration switch will be provided. The requirement for manual reset assures that the cooling tower will be visited to determine the cause of excessive vibration.



Basin Heater:

11.2 *Add the following paragraph in the Cold Water Basin section:* Provide a system of electric immersion heaters and controls for each cell of the tower to prevent freezing of water in the collection basin during periods of shutdown. The system shall consist of one or more stainless steel electric immersion heaters installed in threaded couplings provided in the side of the basin. A NEMA 4 enclosure shall house a magnetic contactor to energize heaters; a transformer to provide 24-volt control circuit power; and a solid-state circuit board for temperature and low water cut-off. A control probe shall be located in the basin to monitor water level and temperature. The system shall be capable of maintaining 40°F water temperature at an ambient air temperature of _____ °F.

■ The Marley basin heater components described at left represent our recommendation for a reliable automatic system for the prevention of basin freezing. They are normally shipped separately for installation at the jobsite by the installing contractor. When purchased in conjunction with the enhanced Control System option, however, they are customarily factory-mounted and tested.

Submerged in basin water, in which zinc ions are present, copper immersion heaters must not be used. Insist upon stainless steel.

The ambient air temperature that you insert in the specifications should be the lowest 1% level of winter temperature prevalent at site.

Fan Motor Variable Speed Drive:

Marley All Weather ACH550 System

6.4 *Add the following paragraph in the Mechanical Equipment section when VFD is used with customers Building Management System:* A complete UL listed Variable Speed Drive system in a NEMA 1 indoor, NEMA 12 indoor or NEMA 3R outdoor enclosure shall be provided. The VFD shall use PWM technology with IGBT switching and integrated bypass design. The VFD shall catch a fan spinning in the reverse direction without tripping. The panel shall include a main disconnect with short circuit protection and external operating handle, lockable in the off position for safety. The VFD system shall receive a

■ Marley VFD drive systems are designed to combine absolute temperature control with ideal energy management. The cooling tower user selects a cold water temperature and the drive system will vary the fan speed to maintain that temperature. Precise temperature control is accomplished with far less stress to the mechanical equipment components. The improved energy management provides fast payback.

Specifications	Specification Value
<p>speed reference signal from the Building Management System monitoring the tower cold-water temperature. As an option to receiving the speed reference signal from a building management system, the drive must have the capability to receive a 4-20 ma temperature signal from an RTD transmitter. The VFD shall have an internal PI regulator to modulate fan speed maintaining set point temperature. The drive's panel display shall be able to display the set-point temperature and cold-water temperature on two separate lines. The bypass shall include a complete magnetic bypass circuit and with capability to isolate the VFD when in the bypass mode. Transfer to the bypass mode shall be manual in the event of VFD failure. Once the motor is transferred to the by-pass circuit the fan motor will run at constant full speed. The bypass circuit will not modulate ON and OFF based on cold-water temperature. The application must be able to handle very cold water while VFD is in a by-pass mode. Operator controls shall be mounted on the front of the enclosure and shall consist of start and stop control, bypass/VFD selection, Auto/Manual selections, manual speed control. To prevent heating problems in the cooling tower fan motor, the VFD system shall de energize the motor once 25% motor speed is reached and cooling is no longer required. The cooling tower manufacturer shall supply VFD start-up assistance. Tower vibration testing throughout the speed range is required to identify and lockout any natural frequency vibration levels which may exceed CTI guidelines.</p>	

Specifications

Specification Value

Marley Premium VFD System:

6.4 *Add the following paragraph in the Mechanical Equipment section when VFD is used as a stand alone system:*
 A complete UL listed Variable Speed Drive system in a NEMA 12 indoor or NEMA 3R outdoor enclosure shall be provided. The VFD shall use PWM technology with IGBT switching and integrated bypass design. The VFD shall catch a fan spinning in the reverse direction without tripping. The panel shall include a main disconnect with short circuit protection and external operating handle, lockable in the off position for safety. The system shall include a solid state, PI temperature controller to adjust frequency output of the drive in response to the tower cold-water temperature. The temperature of the cold water and set point shall be displayed on the door of the control panel. The bypass shall include a complete magnetic bypass circuit with capability to isolate the VFD when in the bypass mode. Transfer to the bypass mode shall be automatic in the event of VFD failure or for specific trip conditions allowing safe transfer of utility voltage to the motor. Automatic bypass with an earth ground condition is not allowed. The bypass contactor shall be cycled on and off while operating in bypass, to maintain the set-point temperature of the cold water. The drive design shall be operated as a stand- alone system without the need for a BMS system. Operator controls shall be mounted on the front of the enclosure and shall consist of start and stop control, bypass/VFD selector switch, Auto/Manual selector switch, manual speed control, and solid-state temperature controller. An emergency bypass selector switch internal to the panel allowing the cooling tower fan motor to be run at full speed shall be furnished. To prevent heating problems in the cooling tower fan motor, the VFD system shall de-energize the motor once 25% motor speed is reached and cooling is no longer required. The VFD shall include de-icing logic with auto canceling and adjustable time. Speed in De-Ice mode shall not exceed 50 % motor speed. The cooling tower manufac-



Specifications	Specification Value
<p>turer shall supply VFD start-up assistance. Tower vibration testing throughout the speed range is required to identify and lock-out any natural frequency vibration levels which may exceed CTI guidelines.</p> <p>Miscellaneous Options</p> <p>Equalizer Flume Weir Gates:</p> <p><u>11.2</u> <i>Add the following paragraph under Cold Water Collection Basin:</i> The interconnecting flume between cells shall be equipped with a removable cover plate to permit the shutdown of one cell for maintenance purposes, or to permit independent cell operation.</p> <p>Premium Efficiency Motor:</p> <p><u>6.3</u> <i>Replace paragraph 6.3 with the following:</i> The complete mechanical equipment assembly for each cell shall be supported by a rigid, hot-dip galvanized steel structural support that resists misalignment between the motor and sheaves (pulleys). For belt-drive towers with motors inside the airstream, motors shall be mounted on an adjustable base that swivels outside the access door for maintenance. For belt-drive towers with motors mounted outside the airstream, a protective cover shall be mounted over the motor and sheave to protect it from the weather and prevent inadvertent contact. The mechanical equipment assembly shall be warranted against any failure caused by defects in materials and workmanship for no less than five (5) years following the date of tower shipment. This warranty shall cover the fan, speed reducer, motor, drive shaft and couplings, and the mechanical equipment support. The bearing assemblies and V-belts shall be warranted for 18 months.</p>	<ul style="list-style-type: none"> ■ Where it is your intention to be able to operate both cells of the tower while the flume cover plate is installed, separate outlet connections, float valves and overflows must be provided for each cell. Likewise, this would require separate sensors and controls for basin heater systems, if installed. ■ NEMA premium efficiency motor with a five year warranty enhances the standard five year mechanical equipment warranty of the MD cooling tower.

Specifications	Specification Value
<p>Sound Control:</p> <p><u>1.2</u> <i>Add the following paragraph under Base:</i> The cooling tower shall be quiet operating, and shall produce an overall level of sound no higher than ____ dBA, measured at the critical location indicated on the plans.</p>	<ul style="list-style-type: none"> ■ Sound produced by a standard MD tower operating in an unobstructed environment will meet all but the most restrictive noise limitations—and will react favorably to natural attenuation. Where the tower has been sized to operate within an enclosure, the enclosure itself will have a damping effect on sound. Sound also declines with distance—by about 5 or 6 dB(A) each time the distance doubles. Where noise at a critical point is likely to exceed an acceptable limit, you have several options—listed below in ascending order of cost impact: <ul style="list-style-type: none"> • In many cases, noise concerns are limited to night time, when ambient noise levels are lower and neighbors are trying to sleep. You can usually resolve these situations by using two speed motors in either full / half speed or full / ⅓ speed configuration, and operating the fans at reduced speed without cycling “after hours”. (The natural night time reduction in wet-bulb temperature makes this a very feasible solution in most areas of the world, but the need to avoid cycling may cause the cold water temperature to vary significantly.) • Variable speed drives automatically minimize the tower's noise level during periods of reduced load and/or reduced ambient without sacrificing the system's ability to maintain a constant cold water temperature. This is a relatively inexpensive solution, and can pay for itself quickly in reduced energy costs. • Where noise is a concern at all times (for example, near a hospital), the best solution is to oversize the tower so it can operate continuously at reduced (⅓ or ½) motor speed even at the highest design wet-bulb temperature. Typical sound reductions are 7 dB(A) at ⅓ fan speed or 10 dB(A) at ½ fan speed, but larger reductions are often possible. • The most extreme cases may require discharge sound attenuator sections—however, the static pressure loss imposed by discharge attenuators may necessitate an increase in tower size. Your Marley sales representative will be able to help you meet you sound requirements.



COOLING TECHNOLOGIES

7401 WEST 129 STREET
 OVERLAND PARK, KANSAS 66213
 UNITED STATES
 913 664 7400
 spxcooling@spx.com
spxcooling.com

In the interest of technological progress, all products are subject to design and/or material change without notice.
 ©2010 SPX Cooling Technologies, Inc.
 Printed in USA | MD-TS-10