

/ Marley Class 800 Cooling Tower /

Seawater Service — Product Specifications



Specifications / Base

Base	4
Thermal Performance	5
Design Loading	5
Circulating Water Quality	6
Structure	7
Mechanical Equipment	8
Fill and Drift Eliminators	10
Fan Cylinders	11
Water Distribution System	11
Cell Partitions	12
Access and Safety	12
Scope of Work	13

Specifications / Options

Options to Maximize Local Scope of Supply	
Concrete Mechanical Supports	14
Bottom-Supported Fill	14
Concrete Parapets and Stairways	14
Driveshaft Material Options	
Carbon Fiber Driveshaft / 316 Stainless Steel Couplings	15
Access and Maintenance Options	
Vertical Ladder at End of Tower	15
Second Stairway at Other End of Tower	15
Cased Stairway	16
Mechanical Equipment Portable Access Catwalk	16
Mechanical Equipment Permanent Access System	16
Endwall Derrick	16
Control Options	
Control System	17
Low Oil Switch	17
Vibration Limit Switch	18
Variable Speed Drive	18
Miscellaneous Options	
Clog Resistant Fill	19
Windwalls	19
Fan Cylinder View Port	20
Low Noise Tower	20

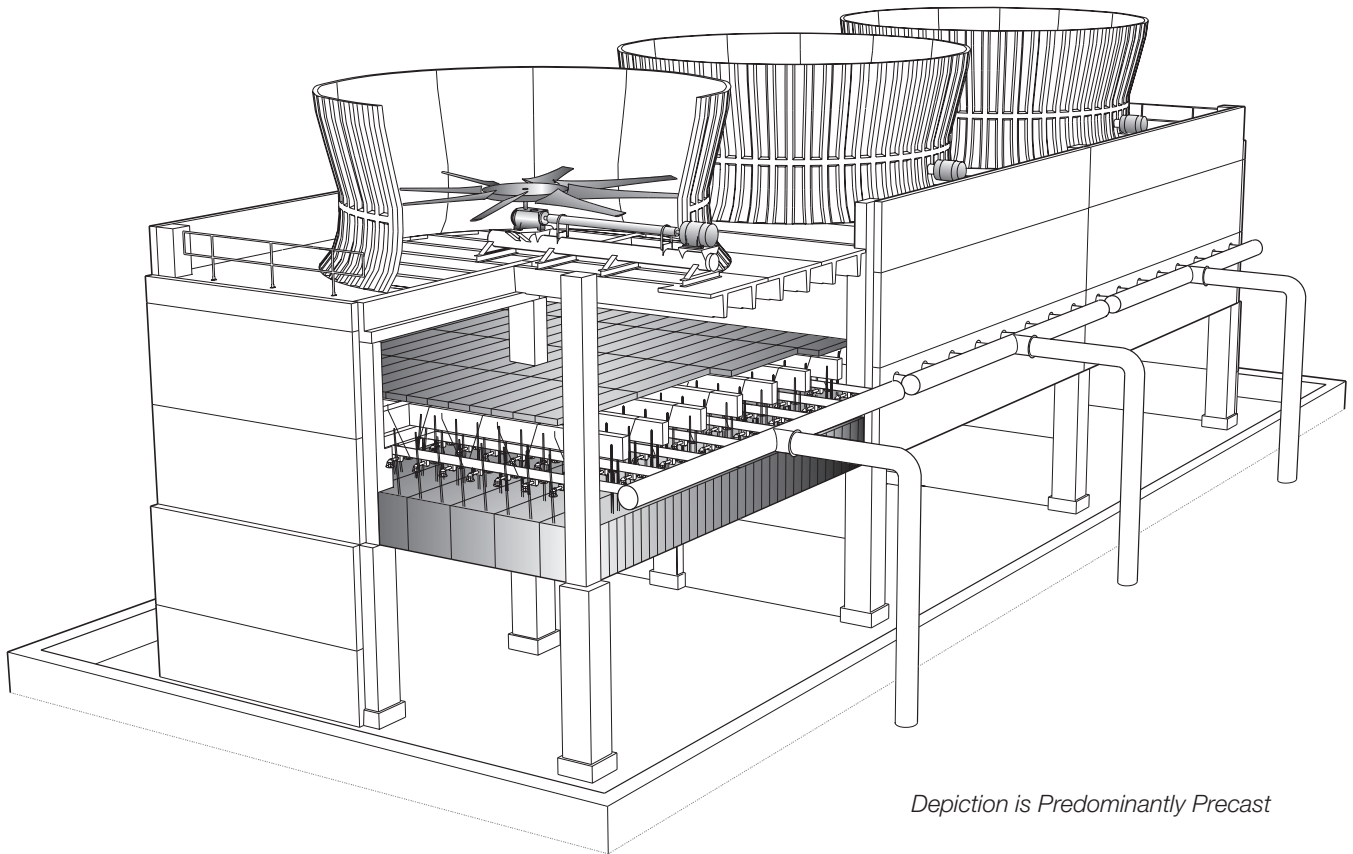

Depiction is Predominantly Precast

Class 800 cooling towers are mechanical draft, film fill, concrete counterflow cooling towers. Although designed to serve all cooling water systems, the construction described in this specification applies primarily to the rigors associated with seawater service.

Class 800 towers utilize both precast and cast-in-place construction techniques to meet the quick schedules and competitive pricing required in today's market. They incorporate the latest cooling tower technology—both in structure and components—developed by Marley in over 80 years of cooling tower experience.

This publication relates the appropriate generic language to use in describing a cooling tower of the Class 800 type. It also explains why certain items and features are important enough to specify with the intention of insisting upon compliance by all bidders. The left hand column of all pages provides suggested text for the various specification paragraphs, whereas the right hand column comments on the value to the user of the items and features described by that text.

Pages 4 through 13 indicate those paragraphs that are descriptive of a cooling tower which will not only accomplish the specified thermal performance, but which will include all normal operation and maintenance-enhancing accessories and features. It will also incorporate those standard materials which testing and experience have proven to provide best results in sea water service.

Pages 14 through 20 provide some paragraphs intended to add those features, components, and materials that will customize the tower to meet the user's requirements.

Space does not permit definition and explanation of all of the possible options that can be applied to the Class 800 tower. SPX Cooling Technologies realizes that you, the purchaser, must be satisfied with the tower's characteristics, and we are prepared to provide any enhancement that you are willing to define and purchase.

Specifications	Specification Value
<p>1.0 Base:</p> <p>1.1 Furnish and install an induced draft, counterflow-type, field erected, film fill, industrial duty, concrete cooling tower of ____ cell(s), situated as shown on the site plan. The limiting overall dimensions of the tower shall be ____ wide x ____ long x ____ high to the top of the fan cylinders. Total operating horsepower of the fans shall not exceed ____ hp. Tower design shall be approved by Factory Mutual without the need for a fire-protection sprinkler system.</p> <p>1.2 It is the intent of these specifications that the bidder shall have the option to utilize either precast techniques, formed-in-place techniques, or a reasonable combination of both in the construction of the tower. The choice of construction technique shall be based upon the bidder's ability to meet the required construction time frame outlined in the Owner's inquiry documents, and shall be subject to final agreement between the Owner and bidder. In all cases, appropriate guidelines promulgated by the American Concrete Institute (ACI) shall be strictly adhered to.</p>	<p>■ Your specification base establishes the type, configuration, material, and physical limitations of the cooling tower to be quoted. During the planning and layout stages of your project, you may have focused your attention on a cooling tower selection that fits your space allotment, and whose power usage was acceptable. Limitations on physical size and total operating horsepower avoid the introduction of disruptive influences. Even further control of this problem will result if you specify the number of cells, and the maximum fan hp/cell.</p> <p>You are specifying a counterflow tower, which is a type noted—and usually specified—for its economical use of ground space on projects where the required thermal performance is very difficult. The one you have chosen to specify utilizes film fill, which normally provides maximum cooling effect in significantly less area than would be required by a splash fill tower.</p> <p>You are also specifying materials of construction which, although premium in their costs, are capable of resisting the effects of sea water that would rapidly destroy towers constructed of more traditional materials. Long life expectancy and excellent fire resistance are typical characteristics of this tower.</p> <p>Note: If it is your intention to evaluate offerings on the basis of first cost, plus the cost of ownership and operation, please be clear in your inquiry documents regarding the parameters under consideration, as well as the value that you intend to place upon each of them. (i.e. Dollars per hp; dollars per ft. of pump head; dollars per sq. ft. of basin area; etc.) They WILL influence the sizing of the tower.</p>



Specifications	Specification Value
<p>2.0 Thermal Performance:</p> <p>2.1 The tower shall be capable of cooling _____ GPM (L/s) of water from _____ °F (°C) to _____ °F (°C) at a design entering air wet-bulb temperature of _____ °F (°C). The cooling tower manufacturer shall guarantee that the tower supplied will meet the specified performance conditions when the tower is installed according to plans.</p> <p>2.2 The purchaser will arrange for an on-site thermal performance test, to be conducted in the presence of the manufacturer and owner, and under the supervision of a qualified, disinterested third party in accordance with CTI (Cooling Technology Institute) Standard ATC-105. The test shall be performed during the first full year of operation. If the tower fails to perform within the limits of test tolerance, then the cooling tower manufacturer will install additional cells and/or make such corrections as are agreeable to the owner and shall pay for the cost of a retest. If the tower still fails to perform as specified, then the manufacturer shall make such reimbursements as are appropriate and agreeable to the owner to compensate for the performance deficiency.</p> <p>3.0 Design Loading:</p> <p>3.1 The tower and all its components shall be designed to withstand a wind load based on ASCE-7 and a seismic load based on UBC. As a minimum, a stability load of 2½% shall be applied to the structure. For non-domestic jobs, a minimum design wind load of 30 psf (1.44kPa) shall be used. Fan decks and other work levels shall be designed for a uniform load of 60 psf (2.9kPa), or a concentrated live load of 600 lbs (272kg). Allowable deflection at 60 psf (2.9kPa) uniform load shall be 1/180 of span. Fill and fill supports shall be capable of withstanding a 60 psf (2.9kPa) live load. Guardrails shall be capable of withstanding a concentrated live load in any direction.</p>	<p>■ Your reason for purchasing a cooling tower is to obtain a continuing flow of cooled water as defined in the paragraph at left. If the tower that you purchase is incapable of performing as specified, then you will not have received full value for your investment.</p> <p>Bear in mind that the size—and cost—of a cooling tower varies directly with its true thermal capability. This paragraph is intended to protect you against either intentional or inadvertent undersizing of the tower by the manufacturer. Judging the level of performance of a cooling tower on critical processes is never easy, and the potential risk of a non-performing cooling tower usually causes the requirement for a mandatory acceptance test to be very desirable.</p> <p>Your contract with the successful bidder should establish the acceptable remedies for missed performance, which might include:</p> <ul style="list-style-type: none"> • The addition of one or more cells of tower, as necessary, to bring the cooling tower to the specified level of performance. This is usually limited to the scope of work as defined in the specifications, which means that you (the owner) will have to pay for the additional basin, wiring, starters, piping, etc. • The reimbursement of a portion of the total contract price equal to the percentage deficiency in performance. <p>Under no circumstances should you allow the manufacturer to repitch the fans to increase motor brake horsepower above that shown in the proposal. That creates additional operating costs that will continue for the life of the tower—and imposes no penalty on the manufacturer.</p> <p>■ The design values indicated in paragraph 3.1 are the minimum allowables under normal design standards. If your geographic location dictates higher wind load, earthquake load, or deck loading values, please make the appropriate changes.</p>

Specifications	Specification Value	
4.0 Circulating Water Quality:		
4.1 It is anticipated that the circulating water will have the following characteristics:	<p>■ For purposes of this specification, "normal" circulating water conditions are defined as follows:</p> <ul style="list-style-type: none"> • A pH level between 6.5 and 9.0. • A chloride content below 70,000 ppm (NaCl) — or below 43,000 ppm (Cl⁻). • A sulfate content (SO₄) below 3000 ppm. (Sulfates can attack concrete, and contribute to scale.) • An ammonia (NH₃) below 10 ppm. • Calcium (CaCO₃) below 2500 ppm. • No oil, grease, fatty acid, organic solvents or free fiber content. • Silica (SiO₂) below 150 ppm. • A maximum hot water temperature of 125°F (52°C). • Aerobic Bacteria Standard Plate Count <10,000 cfu/ml. • Total suspended solids (TSS) below 50 ppm. • No significant contamination with unusual chemicals or foreign substances. • For towers of concrete construction, it is imperative that a slightly positive saturation (Langelier) index be maintained. <p>If your circulating water quality is significantly less severe than the above parameters would indicate, some reduction in the materials specifications may be allowed. Where there is any question in your mind, please provide Marley with an analysis of your makeup water, along with the number of concentrations you intend to permit in your circulating water. Better still, since the quality of the water in a cooling tower soon reflects the quality of the surrounding air, an analysis of the circulating water from another cooling tower on site, if one exists, might be very informative.</p> <p>Where the tower's incoming hot water temperature exceeds 52°C (125°F), details of thermal expansion provisions become increasingly important. Depending upon the size of the tower, and the resultant safety margins, some changes in tower assembly may be required.</p> <p>Except for those unusual operating situations where the circulating water may be so laden with suspended solids, algae, fatty acids, product fibers, active organisms reflected in BOD or bacteria count, and the like, that plugging of the fill is a probability, reasonable attention to the hardware materials and/or their coatings is all that is normally required. Please work with your local Marley sales representative.</p>	
pH range		_____to _____
Chlorides (NaCl)		_____ ppm
Sulfate (SO ₄)		_____ ppm
Sulfides		Less than 1 ppm
Ammonia (NH ₃)		_____ ppm
Calcium (CaCO ₃)		_____ ppm
Silica (SiO ₂)		_____ ppm
Organic Solvents		None
Max. water temperature		_____ °F (°C)
Bacteria Std Pl Count	_____ cfu/ml	
Saturation Index	0.0 to 1.0	
4.2 The specifications, as written, are intended to indicate those materials that will be capable of withstanding the above water quality in continuing service. They are to be regarded as minimum requirements. Where components peculiar to individual tower designs are not specified, the manufacturer shall take the above water quality into account in the selection of their materials of manufacture.		

Specifications	Specification Value
<p>5.0 Structure:</p> <p>5.1 All concrete shall provide minimum 2" (51 mm) cover over reinforcing steel per ACI 318, and shall be designed for 5000 psi (35 MPa) compressive strength at 28 days. Reinforcing bars shall be deformed and shall comply with ASTM A615 Grade 60. All concrete shall use Type II Portland Cement and shall be air entrained with air contents indicated in ACI 318. Cement mix density shall be 658 lb/yd³ (390 kg/m³) of concrete. The use of fly ash or curing agents shall be as approved by the owner.</p> <p>5.2 Structural framing connections shall be bolted as required. No field welding will be allowed. Structural framing hardware shall be silicon bronze. Bidders shall include with their quotation complete column base load tables for all specified loading conditions. Transverse and longitudinal column spacing shall not exceed 40'-0" (12.2m) on centers.</p> <p>5.3 If precast, the concrete casing shall be bolted to the columns. The casing shall provide support for internal structure and components, and shall stiffen the structure for wind and seismic loads. Structural casing hardware shall be silicon bronze. Bolt heads, threads and nuts that are exposed to flowing water shall be covered with plastic covers to prevent erosion.</p> <p>5.4 Structural support beams may be cast-in-place or precast. Precast, if used, shall rest on neoprene bearing pads to avoid abrasion and localized stresses. Prestressed members shall not be used in the wetted area of the tower. Where prestressed members are used, tendon anchorage protection shall be provided. Torch-cutting of prestressed tendons at the concrete face will not be allowed.</p> <p>5.5 Whether prestressed or cast-in-place, the fan deck shall act as a working platform for operation and maintenance personnel. It shall have a broom finish for skid resistance.</p>	<p>■ SPX Cooling Technologies designs to ACI guidelines because they are considered to be both definitive and suitably conservative. If other authorities are to govern the design, please define them clearly in your specification and/or inquiry documents.</p> <ul style="list-style-type: none"> • Required amount of entrained air depends on the severity of exposure and nominal aggregate size. Generally, if a cooling tower is constructed in an area where ice can form, the exposure is severe. • Type II cement is our recommendation for the water quality limitations indicated on page 6. High sulfate levels may dictate Type V Portland cement. Also using condensed silica fume in an amount up to 10% by weight of cement is advised. The silica fume reduces chloride ion intrusion. • The indicated mix density represents 7 bags of cement (USA) per cubic yard (.76 m³) of concrete. <p>To have structurally designed their offerings, bidders will have had to develop the loading diagrams specified. Please ask for them.</p> <p>Silicon bronze, while very resistant to corrosion in a chloride environment, is subject to erosion in high-flow areas. Therefore, plastic cups, designed for this service, are used to prevent direct water impingement on the hardware.</p>

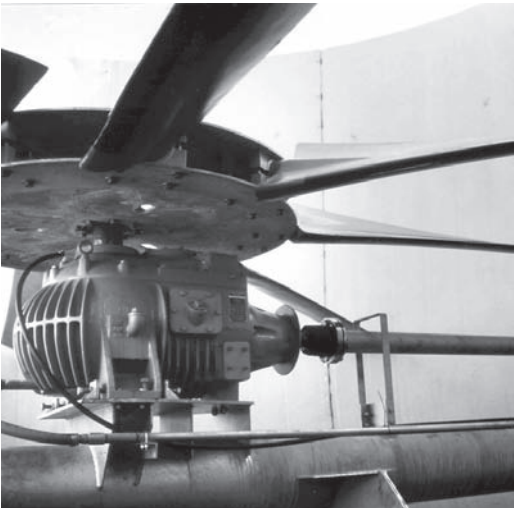
Specifications	Specification Value
<p>6.0 Mechanical Equipment:</p> <p>6.1 The primary air delivery system for each cell shall consist of an electric motor, an extended drive shaft, a geared speed-reduction unit, a multi-bladed propeller-type fan, and a rigid unitized support.</p> <p>6.2 Motors shall be ___-speed, single winding, variable torque, ___ hp maximum, TEFC, and specially insulated for cooling tower duty. Speed and electrical characteristics shall be ___ RPM, ___ phase, ___ hertz, ___ volts. If the load applied to the motors exceeds 90% of their nameplate rating, then they shall have a 1.15 service factor. The service factor beyond 1.0 shall not be considered available for load.</p> <p>6.3 Motors shall be located outside the fan cylinders and shall be connected to the speed reducers by tubular, extended, full floating, non-lubricated drive shafts. Drive shaft tubes and flanges shall be manufactured of type 316 stainless steel. Couplings shall be cast 316 stainless steel, joined to the drive shaft by flexible neoprene bushings and type 316 stainless steel inserts. Connecting hardware shall be 316 stainless steel. Drive shaft assemblies shall be dynamically balanced at the factory at full motor speed. Two galvanized steel drive shaft guards anchored to the mechanical equipment support shall surround the drive shaft for containment in the event of failure. The drive shaft guards shall be triple-epoxy-coated after galvanizing.</p> <p>6.4 Gear reduction units shall be rightangle type, utilizing helical and/or spiral bevel matched gear sets. Cases shall be triple-epoxy-coated, ASTM Class 20, gray cast iron. Bearings shall be tapered roller type. Gears and bearings shall be splash-lubricated in a bath of oil, and units shall be capable of operating in either forward or reverse with equal facility. Speed reduction units using external oil pumps will not be allowed.</p>	<ul style="list-style-type: none"> ■ Typical speed choices are "single" or "two". Two-speed motors are worthy of your consideration because of the increased controllability they offer—and because of their significantly reduced annual power requirements. • For 60 Hz power, single-speed design is 1800 RPM, and normal two-speed design is 1800/900 RPM. • For 50 Hz power, single-speed design is 1500 RPM, and normal two-speed design is 1500/750 RPM. <p>Change the motor specifications to indicate the characteristics you require—dual winding—explosion proof—1800/1200 (1500/1000) RPM—space heaters, etc.</p> <p>The drive shaft turns at the motor speed and is, therefore, most sensitive to operational imbalance. Stainless steel manufacture assures that the drive shaft will not become unbalanced as a result of corrosion.</p> <p>See page 15 for optional type 316 stainless, and carbon fiber drive shafts.</p> <p>The Geareducer® is, essentially, the heart of your fan drive system. It must support the fan, rotate the fan at the appropriate speed, and maintain critical fan positioning within the fan cylinders—and must perform these functions reliably through many long years of demanding use.</p> <p>Requiring adherence to the standards specified helps to assure that level of dependability.</p>
	

Specifications	Specification Value
<p>Gear reducers shall meet or exceed the requirements of CTI STD-111 and AGMA Std. 420.04, and service factor at applied horsepower shall not be less than 2.0. They shall be run at the vendor's factory under load to verify acceptable service, and to coat the interior surfaces with a rust-proofing oil prior to shipment.</p>	
<p>6.5 Each cell shall be equipped with an external oil level gauge and gear reducer drain line, terminating at a sight-glass and plug located outside the fan cylinder near the motor.</p>	<p>The extended oil line to an external sight-glass provides a means of checking the level of oil in the Geareducer. It also permits periodic draining of the Geareducer at a convenient location.</p> 
<p>6.6 Fans shall have a minimum of six GRE (glass reinforced epoxy) blades, with appropriate twist and taper to produce maximum airflow capability. All blades shall be fabricated with consistent moment weights to permit the change-out of individual blades without the need for total fan rebalance. Hubs shall be fabricated of hot dip galvanized steel and ductile cast iron, assembled with series 300 stainless steel hardware. Spoke-type hubs, if used, shall be equipped with an FRP hub cover to prevent recirculation of air at the plane of the fan. Hubs shall be statically balanced at the factory.</p>	<p>Many of the large fans used on cooling towers operate at tip speeds approaching 13000 ft/min (66m/s). When the blade tips encounter the occasional solid droplet of water that escapes the eliminators, erosion of the leading edge can occur on fans whose designs do not address this problem. This has, over time, contributed to several fan failures.</p>
<p>6.7 The complete mechanical equipment assembly for each cell shall be supported by a rigid, unitized, torque-tube type support designed to prevent misalignment between the motor and the gear reducer. Support shall be heavy-wall tubular steel, to which heavy plate platforms for the motor and the gear reducer have been welded. Outriggers shall provide structural stability and transmit loads into the tower structure. The assembly shall be hot-dip galvanized after fabrication, and triple-epoxy-coated.</p>	<p>Fans of the size used on large cooling towers are applied at speeds and horsepowers that generate considerable torque—and structural tubular steel resists this torque very effectively. The Marley torque-tube assures that all of the mechanical equipment remains aligned, and that the rotating fan is properly positioned within the fan cylinder. Hot-dipping after fabrication assures that all steel surfaces will be heavily coated with zinc and triple-epoxy-coated for long-term protection against corrosion.</p> 

Specifications

Specification Value

7.0 Fill and Drift Eliminators:

- 7.1** Fill shall be cellular film-type, thermoformed PVC, manufactured of 15 mil (0.38mm) or heavier stock. Fill shall be assembled into sturdy packs, the height of which is the height of the total fill requirement. If a fill height greater than the maximum height of available fill packs is required in order to accomplish the specified thermal performance, a second layer of fill packs may be added, but no more. Limiting the number of interfaces between packs minimizes restrictions that usually cause fill clogging.
- 7.2** Fill shall be supported on centers as required to accommodate operational loads, as well as the specified 60 psf (2.9 kPa) live load. The support system shall not obstruct airflow through the fill. Fill shall be suspended from the primary support beams by type 316 stainless steel structural tubes and hangers attached to glass-reinforced nylon support pins installed in holes formed in the concrete beams.
- 7.3** Drift eliminators shall be thermoformed of 17 mil (0.43mm) or heavier PVC. They shall be cellular type, triple-pass, and shall limit drift losses to no more than 0.010% of the design water flow rate. They shall be factory-assembled into easily-handled packs that nest together to form a continuous plane of drift eliminators throughout the plan area of each tower cell. Eliminators shall be supported by framing girts on no greater than 6'-0" (1.83m) centers, and shall be elevated to clear the spray nozzles by no less than 24" (610mm).

- In film-fill counterflow towers, great care is taken to assure full and even coverage of the fill with circulating water. Multiple layers of fill packs tend to defeat this effort by causing the water to redistribute itself after each layer. Also, where layers meet, normal overlap of the fill cells significantly reduces flow paths for air and water. This makes airflow (and fan horsepower) unpredictable, and can contribute to eventual plugging of the fill.

Hanging fill is unique in that excessive or unforeseen loads applied to the fill cannot bring about damage to the tower structure. The support system can be designed to accommodate ice and fouling loads far in excess of normal operating and live loads, yet reach failure well short of the yield strength of the fill support beams. This very desirable feature is not achievable with bottom supported fill. Also, hanging fill is free of the unavoidable air blockages that occur with bottom-supported fill.

Hanging fill is also very forgiving of fire. If a fire occurs, it burns through the support area and the affected portion of the fill falls into the cooling tower basin where it no longer contributes to the fire. Factory Mutual recognizes this characteristic of hanging PVC fill, and considers it non-conductive to the spread of fire. Multiple layers of fill, particularly in a bottom supported mode, exhibit the opposite characteristic. In layered design, fire spreads horizontally throughout the fill much faster than the rate at which any given portion of the fill will fall away.

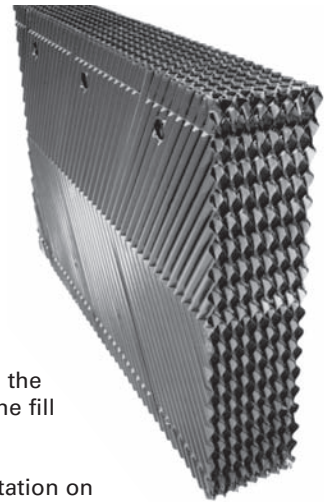

The applied water temperature limitation on normal PVC is 125°F (52°C). If your design water exceeds 125°F (52°C), or if you anticipate temperature excursions beyond that level, please discuss the use of CPVC, or other commercially available formulations, with your Marley sales representative. They are routinely applied at temperatures of 150°F (66°C), and greater.

Drift rate varies with design water loading, air rate, drift eliminator depth, density and their proximity to the spray nozzles. The indicated rate of 0.005% is easily achievable without premium cost. If a lower rate is required, please discuss with your Marley sales representative.

Specifications

Specification Value

8.0 Fan Cylinder:

8.1 Fan cylinders shall be molded FRP, no less than 6 ft (1.83 m) high, with eased inlets to promote smooth airflow at blade tips. The operating plane of the fan shall be at a level above the fan deck of at least 15% of the overall fan diameter. Fan tip clearance shall not exceed 0.5% of the fan diameter. If velocity recovery fan cylinders are used, they shall have a maximum flare angle of 12°, with a maximum assumed velocity recovery of 75% of the difference in average velocity pressure. Each fan cylinder segment shall be anchored to the fan deck. Fan cylinder connection and anchorage hardware shall be silicon bronze.

■ Fiberglass-reinforced polyester fan cylinders provide the close tip clearances and smooth airflow contour necessary for good fan performance. The inert, noncorroding nature of FRP assures that these characteristics will persist. *Marley Difference "Item A-1a"* explains the need for the specification language indicated at left.



If fire-retardant FRP is required or preferred for fan cylinders, please add the words "having a flame spread rate below 25" after "FRP".

9.0 Water Distribution System:

9.1 Hot water shall be distributed to the fill in each cell via a system of headers, laterals, branch arms, and nozzles, installed in the region above the fill and beneath the drift eliminators. Headers may be either RTR (reinforced thermosetting resin) or PVC. Laterals shall be PVC. Branch arms and nozzles shall be molded polypropylene. The joint between branch arms and nozzles shall be threaded so nozzles can be easily removed for cleaning of the branch arms. Nozzles shall be of the large orifice, low-pressure, down-spray type, having no moving parts or restrictors that will promote clogging.

■ This "side inlet" method of piping the cooling tower (see illustration on page 3) permits you to provide a header at the base of the tower, along with separate risers for each cell. Using this method, you may conveniently valve off cells on an individual basis.



In cold weather regions, you should also consider running a drain line from the riser to the cold water basin to drain the riser during shutdown in freezing weather.

Bypasses, if used, should be designed only after thorough discussion with your Marley sales representative.

9.2 The piping system shall be sized for a flow velocity that will insure relatively equal flow to all areas of the cooling tower fill. Headers shall be equipped with individual 25 psi flanged inlets, drilled to conform to Class 125 ANSI dimensions, located approximately 1'-0" (305mm) outside the tower's side-wall at or near the transverse centerline of each cell. All headers having a diameter of 24" (610mm) or larger shall be vented to atmosphere by an open standpipe at the downstream end of the header.

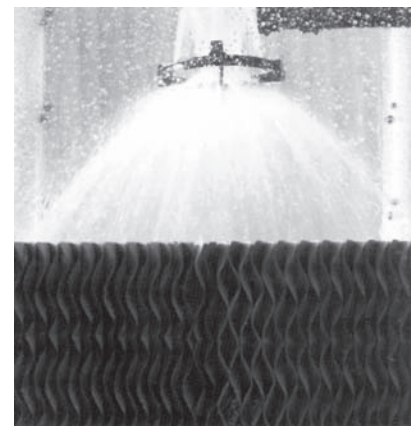
Full and even water distribution over the fill is absolutely critical to the design performance of a film-filled counterflow cooling tower.



Specifications	Specification Value
<p>10.0 Cell Partitions:</p> <p>10.1 The tower shall be partitioned such that the fan(s) of each cell can be operated and cycled independent of the remaining cells. Partitions shall extend across the tower between cells from side-wall to side-wall, and from the bottom of the fill upward to the underneath side of the fan deck floor. Partitions may be constructed of reinforced concrete or 8 oz/sq ft (2.4kg/m²) corrugated FRP sheets supported by an FRP or stainless steel framework.</p> <p>11.0 Access and Safety:</p> <p>11.1 The tower shall be designed and equipped to provide comfortable, safe access to all components requiring routine inspection and maintenance.</p> <p>11.2 The fan deck of the tower shall be surrounded by sturdy hot-dip galvanized steel handrails, kneerails and toeboards. Handrails shall be 42" (107mm) high and conform to OSHA standards.</p> <p>11.3 One endwall of the tower shall be equipped with an FRP or stainless steel stairway rising from the level of the cold water basin curb to the fan deck. Stairs shall be 45° slope, 36" (914mm) wide, with 8" rise and 8" (203mm) run. Treads shall have a nonskid surface. All stairway bolts and fasteners shall be series 300 stainless steel.</p> <p>11.4 Each cell shall have an FRP or stainless steel 30" (762mm) square lift-off access hatch in the fan deck floor, and an FRP or stainless steel ladder leading down to a landing at the drift eliminator level. Each landing shall have a lift-off hatch for entry to the top of the fill and distribution level.</p>	<p>■ Multicell towers must have air plenum partitions between cells. Otherwise, air will be induced downward through an inoperative fan, bypassing the fill of the operating cell. Without these partitions, part-load or off-season operation of the tower would be completely unsatisfactory.</p> <p>Unless complete separation between cells is required for reasons of system operation, transverse partitions below the fill area serve no useful purpose. Extending down to the bottom of the fill, however, these partitions also serve to compartmentalize the fill for possible fire containment.</p> <p>■ The rigors of normal industrial cooling tower operation require that all vital areas of the tower be readily, easily, and safely accessed.</p> <p>Be extremely wary of those manufacturers who suggest that one of your access requirements is not really necessary. Their suggestion may be evidence that such access in their design is difficult—and may very well become a focus of significant cost to you in the future.</p> <div style="text-align: right;">  </div> <div style="text-align: center; margin: 10px 0;">  </div> <p>Stairways are also available at both ends of the tower; and cased for snow and ice protection. See pages 15 and 16.</p> <p>The access doors on other towers may be unreasonably small. Specifying the size of the door will cause those bidders to take exception, alerting you to a potential maintenance headache.</p>

Specifications

Specification Value

11.5 Fan cylinders shall have removable segments of sufficient size to allow removal of all mechanical equipment components, and shall have a coupling guard, conforming to OSHA standards, to shroud that portion of the driveshaft that extends outside the fan cylinder.

See pages 16 and 17 for options related to the removal and replacement of mechanical equipment.

12.0 Scope of Work:

12.1 The cooling tower manufacturer shall be responsible for the design, fabrication, and delivery of materials to the project site, and for the erection of the tower over a concrete basin and foundation. The concrete basin and foundation will be designed and installed by others, based upon certified loads and dimensions provided by the cooling tower manufacturer. Unless otherwise specified, all supply and return piping, risers, valves, pumps, sumps and screens, anchor bolts, controls, electrical wiring, lightning protection, and water treatment equipment will be outside the tower manufacturer's scope of work.

■ Specification paragraph 12.1 at left essentially limits the manufacturer's scope of work to the tower structure and operating components above the level of the cold water basin, which is consistent with past industry practice in many areas of the world.

We suggest to you, however, that it is to your advantage to also include the foundation, concrete cold water basin, and all other cooling tower related work in the manufacturer's scope of work because:

- it assures that all mated components are compatible.
- it assures like quality throughout.
- it provides for best overall construction scheduling.
- it defines project responsibility and accountability.

Please be clear in your specifications and inquiry documents regarding the full scope of work expected. That will help assure that your bid comparisons will be made on as equal a basis as possible—and will help to avoid any misunderstandings during the execution and implementation of the contract.



Specifications	Specification Value
<p>Options to Maximize Local Scope of Supply</p>	
<p>Concrete Mechanical Supports:</p>	
<p><u>6.1</u> <i>Replace this paragraph with the following:</i> The primary air delivery system for each cell shall consist of an electric motor, an extended drive shaft, a geared speed-reduction unit, and a multi-bladed propeller type fan, all supported on a rigid, stable concrete structure.</p>	<p>■ SPX Cooling Technologies recognizes and understands the economic and political value of allowing for the maximum possible local involvement in the overall materials, manufacturing, and labor requirement. The options in this section are designed to both encourage and accommodate that need.</p>
<p><u>6.7</u> <i>Delete this paragraph in its entirety.</i></p>	
<p>Bottom-Supported Fill:</p>	
<p><u>7.2</u> <i>Replace this paragraph with the following:</i> Fill shall be supported on precast concrete beams spanning between primary support members. Neoprene bearing pads shall be placed between the fill beams and the primary support members to prevent abrasion and localized stresses. Beam design and spacing shall accommodate operational loads as well as the specified 60 psf (2.9kPa) live load, but shall not unduly obstruct airflow through the fill.</p>	<p>■ Although the torque-tube support system specified in paragraph 6.7 (page 9) is built to factory-controlled tolerances—and is therefore superior—Marley construction techniques can produce equally stable supports in both precast and cast-in-place concrete.</p> <p>■ With bottom-supported fill, it is especially important to limit the number of fill layers allowed (as specified in paragraph 7.1). This is because the supports themselves add a measure of air blockage through the fill—and provide low water velocity regions where fill clogging can begin.</p> <p style="padding-left: 20px;">If your water quality and condition indicates the possibility of fill clogging, please consider the option for clog-resistant fill indicated on page 19.</p>
<p>Concrete Parapets and Stairways:</p>	
<p><u>11.2</u> <i>Replace this paragraph with the following:</i> The fan deck of the tower shall be surrounded by a concrete parapet no less than 42" (1.067m) high, and conforming to OSHA standards. Parapets may be extensions of the tower casing.</p>	<p>■ Irrespective of the need for local supply, many customers prefer the concrete parapet over the standard handrail. It lends a more finished appearance to the tower—and provides a protective wall behind which routine maintenance materials and equipment can be stored for ready use.</p> <p style="padding-left: 20px;">Note that the change to a concrete stairway does not negate the need for a galvanized steel system of stairway guardrails.</p>
<p><u>11.3</u> <i>Replace the first sentence of this paragraph with the following:</i> One endwall of the tower shall be equipped with a concrete stairway rising from the level of the cold water basin curb to the fan deck.</p>	

Specifications

Specification Value

Drive Shaft Materials Options**Carbon Fiber Drive Shaft / Stainless Steel Couplings:**

- 6.3** *Replace this paragraph with the following:* Motors shall be located outside the fan cylinders and shall be connected to the speed reducers by tubular, extended, full floating, non-lubricated drive shafts. Drive shaft tubes shall be carbon fiber/glass/epoxy composite. Flanges shall be manufactured of type 316 stainless steel, attached to the tube by type 316 stainless steel compression rings. Couplings shall be cast 316 stainless, joined to the drive shaft by flexible neoprene bushings and type 316 stainless steel inserts. Connecting hardware shall be 316 stainless steel. Drive shaft assemblies shall be dynamically balanced at the factory at full motor speed. Two type 316 stainless steel drive shaft guards anchored to the mechanical equipment support shall surround the drive shaft for containment in the event of failure.

Access and Maintenance Options**Vertical Ladder at End of Tower:**

- 11.3** *Add the following to the paragraph:* An FRP or stainless steel vertical ladder and safety cage per OSHA recommendations shall be provided at the other end of the tower.

Second Stairway at End of Tower:

- 11.3** *Change the second sentence to read:* Both endwalls of the tower shall be equipped with an FRP or stainless steel stairway rising from the level of the cold water basin curb to the fan deck.

- Carbon fiber driveshafts are preferred by many customers on the strength of their ability to remain dimensionally unaffected by long stationary periods in direct sunlight. Steel driveshafts may go through temporary imbalance in those circumstances.

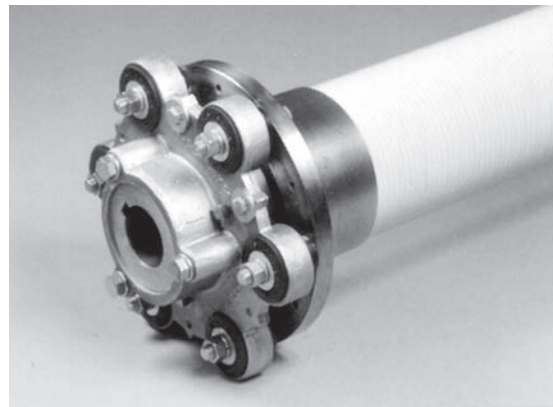

- These are sometimes referred to as "escape" ladders. They are a ready means of egress in case of emergency. They are standard equipment for towers exceeding 200 ft (61m) in length. If you want this ladder on your tower, regardless of length, please make the change indicated at left.
- On long towers, this is a very desirable option for your maintenance people.

Specifications

Specification Value

Cased Stairway:

11.3 *Add the following to this paragraph:*
 The stairway shall be roofed and cased with 16 oz./sq.ft. (2.4 kg/m²) corrugated fire-retardant FRP material to keep out snow and sleet. Roof support headroom shall be 7'-0" (2.134m) above top stairway landing. Latched doors shall be provided at the entrance and exit of the stairway. The door at the fan deck elevation shall open inward to prevent snow and ice build-up from rendering the door inoperable. Stairway side casings shall be translucent for visibility.

■ As the specification wording implies, the cased stairway is of great benefit in those geographic regions where heavy snowfalls are the norm.

Mechanical Equipment Portable Access Catwalk:

11.5 *Add the following to this paragraph:*
 Provide a 24" (610mm) mm wide portable fiberglass grating catwalk, complete with handrail and kneerail, that will extend from the fan cylinder access way to the fan hub/gear reducer/driveshaft region.

■ This catwalk spans girt lines and provides short-term access to the mechanical equipment. It precludes the need to provide temporary planking.

Mechanical Equipment Permanent Access System:

11.5 *Add the following to this paragraph:*
 Each cell shall be equipped with a 24" (610mm) wide, permanently-installed walkway extending from the fan cylinder access way to a work platform at the fan hub / gear reducer / driveshaft region. Catwalk and work platform shall be FRP, and shall be equipped with FRP handrails and kneerails.

■ This system avoids the need to install the temporary catwalk (above) every time you need to perform major maintenance. It also provides a substantial work platform, without which you will have to put down temporary decking. Please check with your Marley sales representative to determine what, if any, effect this permanent fixture in the tower airstream will have on tower performance or operating horsepower.

Endwall Derrick:

11.6 *Add the following paragraph in the Access and Safety section:* A permanent derrick shall be provided at the end of the fan deck to facilitate movement of equipment between the fan deck level and grade. Derrick shall be of a capacity sufficient to handle the motors or the gear reducers. The assembly shall be hot-dip galvanized after fabrication, and triple-epoxy-coated. Power, rigging, and cables will be provided by the owner.

■ If the fan deck level at the end of the tower is not readily accessible by the use of a small crane or "cherry picker", this derrick becomes a very useful option.

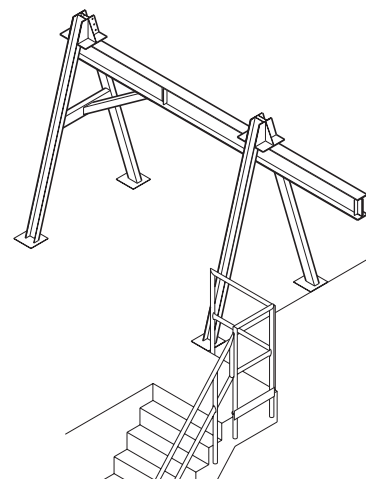

Specifications

Vibration Limit Switch:

- 6.8** *Add the following paragraph in the Mechanical Equipment section:* A single-pole, double-throw vibration limit switch in a NEMA 4 housing shall be installed on the mechanical equipment support for wiring into the owner's control panel. The purpose of this switch will be to interrupt power to the motor in the event of excessive vibration. It shall be adjustable for sensitivity, and shall require manual reset.

Variable Speed Drive:

- 6.7** *Add the following paragraph in the Mechanical Equipment section:* A complete UL listed Variable Speed Drive system in a NEMA 12 indoor or NEMA 3R outdoor enclosure shall be provided. The VFD shall use PWM technology with IGBT switching and integrated by-pass design. The panel shall include a main disconnect with short circuit protection and external operating handle, lockable in the off position for safety. The system shall include a solid state, PID temperature controller to adjust frequency output of the drive in response to the tower cold water temperature. The temperature of the cold water and set point shall be displayed on the door of the control panel. The by-pass circuit shall include a complete magnetic bypass that isolates the VFD when in the bypass mode. Transfer to the bypass mode shall be automatic in the event of VFD failure or for trip faults. The bypass contactor shall be cycled on and off while operating in bypass, to maintain the set-point temperature of the cold water. The drive design shall be operated as a stand-alone system or controlled with a building automation system. The BAS can be the normal source of control and the integrated temperature controller may be used as a backup to the building automation system.

Operator controls shall be mounted on the front of the enclosure and shall consist of start and stop control, bypass/VFD selector switch, Auto/Manual selector switch, manual speed



Specification Value

- Unless specified otherwise, a Marley M-5 vibration switch will be provided. The requirement for manual reset assures that the tower will be visited to determine the cause of excessive vibration.



- Marley VFD drive systems are designed to combine absolute temperature control with ideal energy management. The cooling tower user selects a cold water temperature and the drive system will vary the fan speed to maintain that temperature. Precise temperature control is accomplished with far less stress to the mechanical equipment components. The improved energy management provides fast payback. Indeed, many utilities offer generous rebates for users having installed VFD drives.

Specifications

control, and solid state temperature controller. An emergency bypass selector switch internal to the panel allowing the cooling tower fan motor to be run at full speed shall be furnished.

To prevent heating problems in the cooling tower fan motor and to assure proper gear reducer lubrication the VFD system shall cycle the motor on/off when the minimum allowable motor speed is reached.

The cooling tower manufacturer shall supply VFD start-up and tower vibration testing to identify and lock out any vibration levels which may exceed CTI guidelines.

Miscellaneous Options

Clog-Resistant Fill:

- 7.1** *Change the paragraph to read as follows:* Fill shall be clog-resistant, film-type, thermoformed PVC, manufactured of 15 mil (0.38 mm) or heavier stock. Fill shall be assembled into sturdy packs. Fill shall be designed to be bottom-supported with a minimum number of supports. The fill depth will be chosen to provide the proper thermal performance. To accommodate for various fill heights and/or desired duties, the fill may be installed in multiple layers. Fill can also be installed with an overlay of high-efficiency counterflow film fill, giving maximum thermal performance with minimal fouling.

Windwalls:

- 10.2** *Add the following paragraph in the Cell Partitions section:* A full-length, concrete partition shall also extend from endwall to endwall along the approximate centerline of the tower, rising from the top of the basin to the underneath side of the fill. If endwalls are open for air entry, wind walls shall extend inward at an approximate 45° angle from the corner columns of the end cells to meet the longitudinal partition. The purpose of this partition system will be to prevent falling water from being blown out the leeward face of the tower.

Specification Value

- Please understand that clog-resistant fill provides less heat transfer surface than close-spaced fill, so a somewhat larger cooling tower model than anticipated may be required. Please determine the appropriate model selection in conjunction with your Marley sales representative.

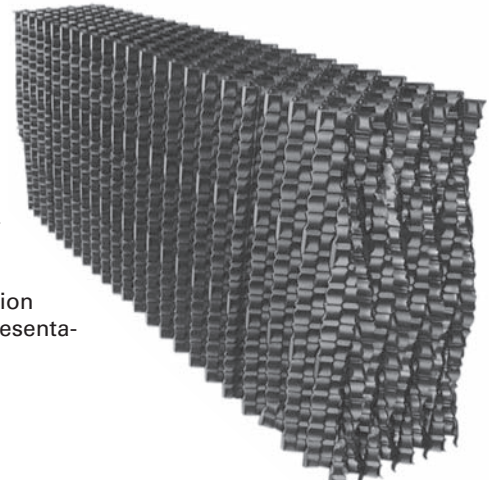

- Without these wind walls, the area surrounding counterflow towers of linear configuration might become unsightly — or in wintertime, potentially dangerous. Towers of other than linear cell configuration may not require wind walls. Please discuss their need with your Marley sales representative.

Specifications	Specification Value
<p>Fan Cylinder View Port:</p> <p><u>8.1</u> <i>Add the following to this paragraph:</i> Each fan cylinder shall include a 6" (152mm) screened view port with a removable plexiglass window.</p> <p>Low Noise Tower:</p> <p><u>1.1</u> <i>Add the following sentence to this paragraph:</i> The cooling tower shall be quiet operating, and shall produce an overall level of sound no higher than ____ dBA, measured at the critical location indicated on the Plans.</p>	<ul style="list-style-type: none"> ■ These view ports allow on-line observation of fan operation. ■ Sound produced by a Class 800 cooling tower operating in an unobstructed environment will meet all but the most restrictive noise limitations – and will react favorably to natural attenuation. Sound declines with distance – by about 5 or 6 dBA each time the distance doubles. Where noise at a critical point is likely to exceed an acceptable limit, you have several options – listed below in ascending order of cost impact: <ul style="list-style-type: none"> • Where a relatively small reduction in noise will satisfy—and the source of concern is in a particular direction—fully casing the near face of the tower may be the answer. Less sound emanates from a cased face than does from an air intake face. However, this may require an increase in the height of the tower in order to recover the lost air intake area. • In many cases, noise concerns are limited to nighttime, when ambient noise levels are lower and neighbors are trying to sleep. You can usually resolve these situations by using two-speed motors in either 1800/900 (1500/750) or 1800/1200 (1500/1000) RPM configuration; and operating the fans at reduced speed without cycling “after hours.” (The natural nighttime reduction in wet-bulb temperature makes this a very feasible solution in most areas of the world, but the need to avoid cycling may cause the cold water temperature to vary significantly.) • Variable speed drives automatically minimize the tower's noise level during periods of reduced load and/or reduced ambient without sacrificing the system's ability to maintain a constant cold water temperature. This is a relatively inexpensive solution, and can pay for itself quickly in reduced energy costs. • Where noise is a concern at all times, the best solution is to oversize the tower so it can operate continuously at reduced (1200, 1000, 900, or 750 RPM) motor speed even at the highest design wet-bulb temperature. Typical sound reductions are 7 dBA at 2/3 fan speed or 10 dBA at 1/2 fan speed, but larger reductions are often possible. • Extreme cases may require special fans or inlet and discharge sound attenuator sections; however, the static pressure loss imposed by attenuators may necessitate an increase in tower size. This is the least desirable approach because of the significant cost impact – and because of the obstruction to normal maintenance procedures. <p>Your Marley sales representative can help you meet your sound requirements.</p>



SPX[®]

COOLING TECHNOLOGIES

7401 WEST 129 STREET
OVERLAND PARK, KANSAS 66213
UNITED STATES
913 664 7400
spxcooling@spx.com
spxcooling.com

In the interest of technological progress,
all products are subject to design and/or
material change without notice.
©2010 SPX Cooling Technologies, Inc.
Printed in USA | SPEC 800MDSW-10