

More Capacity. More Value.
More of What Makes Marley® the Best.



> Marley

Marley Is Raising The Industry Bar – Again.



Sacrifice nothing

If you're looking for maximum value in a package cooling tower, look no further than the latest NC from Marley. After all, why sacrifice productivity for value when you can have both with the Marley NC cooling tower?

Highest capacity

More fully assembled, CTI-certified, deliverable tons of cooling than any other package cooling tower on the market. The NC makes it easier to cool larger applications with more value and shorter installation times.

Highest efficiency

All that capacity is achieved with even less power – lowering operation costs and energy usage – accomplishing ASHRAE 90.1 efficiencies up to six times more than required.

Smaller profile

Increasing capacity and efficiency typically means increasing size. Not with the new Marley NC. Most models are the same or smaller footprint than before. In addition, there is a one- to two-foot height reduction from previous comparable models, saving costs for architectural walls and enclosures.





With higher capacity and efficiency within a smaller footprint, this NC will reduce costs for an even wider array of applications.

More applications

The NC has the right combination of increased efficiency and reduced footprint to bring the performance of a crossflow cooling tower to more applications than ever before.

Marley reliability

As a recognized leader in product quality, the greatest value of all might just be the name on the side. Our reputation, our service and our 87-year history of excellence deliver the peace of mind that comes from knowing you've made a quality choice. Now, more than ever, value is important when looking for the best cooling solution. The new NC from Marley delivers more value than ever before.

Is the Marley NC Right for Your Application?

The best way to see if a Marley NC suits your needs is to have us run a complimentary product match analysis of your specific installation or plans. You can do it yourself or contact your local Marley sales representative.

Find out at [spxcooling.com/update](https://www.spxcooling.com/update)

Enter the key specs you're working with, and make your own selection.

The NC is redefining crossflow package cooling towers.

See increased value from the very beginning.

- Lower shipping costs and global availability. Affordable performance – delivered when you need it, wherever you need it.
- Ease of installation. 88 years in the business have taught us to streamline the installation process and to anticipate the installation needs for numerous applications.



5-year Maintenance-Free System 5 Geareducer

SofTork™ MC Coupling

Standard Low-Sound – High-Efficiency Axial Fan

Optional Easy Fit Guardrails and Safety Cage

- The System 5 Geareducer requires no oil changes for a full five years – the lowest maintenance requirements in the industry.
- SofTork MC Coupling absorbs excessive shock loads at start-up – forgives minor misalignment between the motor and Geareducer. Specifically designed for VFD applications and cooling towers.
- The standard low-sound, high-efficiency axial fan has adjustable-pitch fan blades to permit maximum utilization of rated horsepower – allowing field adjustments to optimize performance.
- Easy fit guardrail and safety cage option for quick, hassle-free field installation.

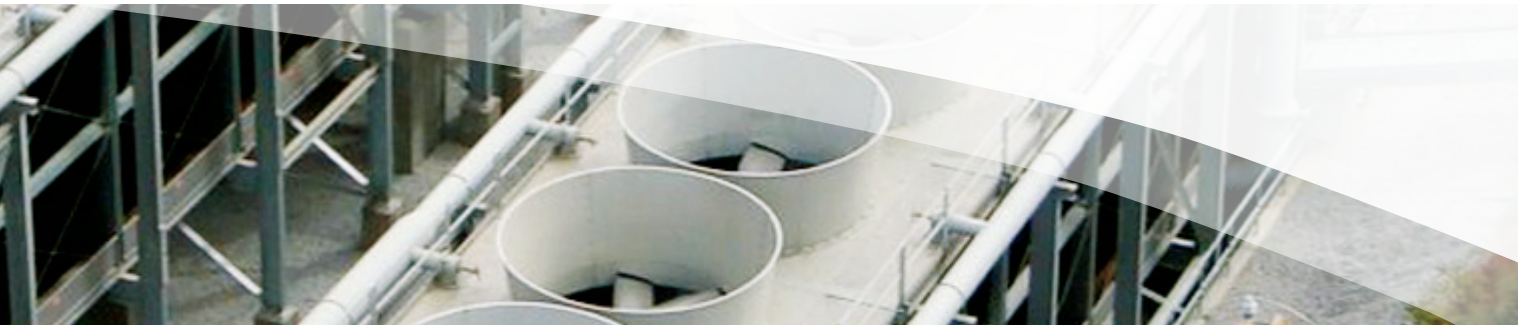

The perfect fit makes all the difference.

See how the best gets even better. There's a Marley NC that's ideal for your application.

Industry-leading features and options of the Marley NC.

- Improved efficiency and increased capacity: Unmatched performance as high as 1139 m³/hr in a single unit.
- Drift rates as low as .001% of design flow rate are available on many standard models – the lowest drift rates of any standard crossflow configuration.
- Air inlet screen horizontal orientation. By removing just the lower screen, complete access to the collection basin is available. Just one more way the new NC is easier to maintain.
- Optional belt drive – the choice is yours. Choose the belt drive for all models up to 45 kW.
- Largest selection of options and accessories. Select and customize your NC with the most optional features of any factory-assembled cooling tower.
- The most CTI-certified low-sound options, with low-sound fans standard on all NC models.

TOWER MODELS	TONS	L	W	H
NC8401	101–198	1988	3912	3105
NC8402	131–277	2559	4318	3124
NC8403	213–423	2559	5537	3638
NC8405	331–515	3016	6071	3651
NC8407	338–690	3626	6401	3651
NC8409	488–782	4235	6833	3651
NC8411*	636–1019	3626	6833	5742
NC8412*	711–1239	4235	6833	5742
NC8413*	692–1214	3726	6833	6888
NC8414*	771–1439	4235	6833	6888

*Two-story modular cells

**Velocity recovery fan cylinders required on some models in this box size

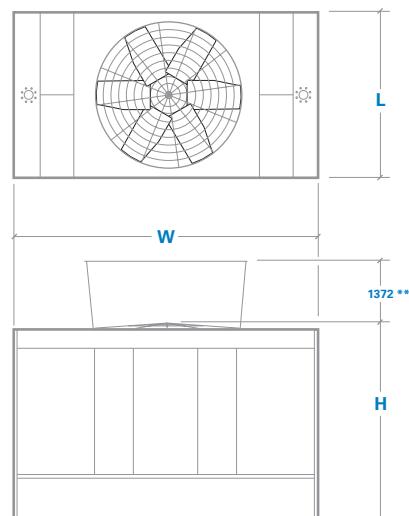

The Marley NC sets the standard on certifications and standards.



More Factory Mutual approved features than ever.

We've added more FM options than ever before, including high wind load applications. The NC will help bring more affordable operation insurance for mission-critical facilities and lower the cost for FM customers. What's more, Marley is still the only manufacturer to provide an FM-approved single-cell crossflow cooling tower.



The NC has codes and certifications covered.

CTI, ASHRAE, ASCE, OSHA, ACOP L8, IBC, FBC, FM, China GB7, Eurovent, ISO, BSI, etc. – the NC is covered with the codes you need now and for the future. Plus, we have more models meeting the China efficiency standards than ever before. And all models are ASHRAE 90.1 compliant.





COOL IS
GREEN
IS COOL™

The new NC is greener, too.

Greater energy efficiency is just the beginning of the green story. The NC employs water-saving strategies to help achieve sustainable building goals. Being green can do more than help with LEED projects – it can boost your bottom line.

Simply put, the new NC from Marley is a package crossflow cooling tower like no other.

ADDITIONAL NC COOLING TOWER PUBLICATIONS

For further information about the NC Cooling Tower – including engineering schematics, data, layout requirements and more – ask your Marley sales representative for a copy or download at spxcooling.com:



Engineering Data



Specifications

OTHER SPX COOLING TECHNOLOGIES PRODUCTS

SPX Cooling Technologies offers a full line of industry leading products – with exceptional support and innovation designed to help you get the most out of your cooling process. Take a look at these other SPX Cooling Technologies products:



Marley NC Alpha
Splash Fill
Cooling Tower



Marley MD
Cooling Tower



Marley Aquatower®
Cooling Tower



Marley AV
Cooling Tower

SPX Cooling Technologies is a world-leading full-line cooling tower and air-cooled condenser manufacturer. The company provides exceptional-quality evaporative cooling towers, fluid coolers and evaporative condensers under the Marley, Recold and Balcke brand names.

SPX®

UNIT 505, BLOCK B
PHILEO DAMANSARA 2
NO. 15 JALAN 16/11
OFF JALAN DAMANSARA
46350 PETALING JAYA, MALAYSIA
60 3 7947 7800
spxcooling.asiapacinfo@spx.com
spxcooling.com

In the interest of technological progress,
all products are subject to design and/or
material change without notice.
©2011 SPX | [sea_NC-10](#)