

/ NC[®] Alpha Steel Cooling Tower /

Engineering Data & Specifications



Engineering Data

Schematic	8
Inlet Connections	12
Outlet Connections	18
Support	20
Freeze Prevention	22
Attenuators	23
Hoisting	24

Specifications / Base

Base	25
Thermal Performance	26
Design Loading	26
Construction	27
Mechanical Equipment	27
Fill, Drift Eliminators and Louvers	28
Hot Water Distribution System	29
Casing, Fan Deck and Fan Cylinder	29
Access	30
Cold Water Collection Basin	30

Specifications / Options

Stainless Steel Options

Stainless Steel Collection Basin	31
Stainless Steel Distribution Basin	31
All Stainless Tower	31

Convenience and Safety Options

Guardrail and Ladder	32
Ladder Extension	32
Ladder Safety Cage	32
Ladder Safety Gate	32
Access Door Platform	34
Plenum Walkway	34
Interior Mechanical Equipment Access Platform	34

Specifications / Options

Control Options

Fan Motor Starter Control Panel	35
Marley TF Terminal Box	35
Vibration Limit Switch	36
Basin Heater	36
Electric Water Level Control	36
Fan Motor Variable Speed Drive	37
Marley Premium VFD System	38

Miscellaneous Options

Motor Outside of the Airstream	39
Fan Cylinder Extensions	39
Inlet Flow Control Valves	40
Equalizer Flume Weir Gate	40
Sound Control	40
Outlet Sound Attenuation	41
Quiet Fan	41
Single Hot Water Inlet Connection	41
Multicell Basin Equalizer Outlets	42
Extended Geareducer Lube Line Dipstick	42
Premium Efficiency Motor	42



NC Alpha towers are steel structure, splash fill, factory assembled, crossflow cooling towers, designed to serve all normal cooling water systems—as well those “dirty water” systems which would place the long term operation of a film fill tower in jeopardy. They evolve from a factory-assembled concept of towers pioneered by Marley some 60 years ago, and incorporate all of the design advancements that our customers have found valuable.

This booklet not only relates the language to use in describing an appropriate **NC Alpha** cooling tower—but also defines why certain items and features are important enough to specify with the intention of insisting upon compliance by all bidders. The left-hand column of pages 25 thru 42 provides appropriate text for the various specification paragraphs, whereas the right hand column comments on the meaning of the subject matter and explains its value.

Pages 25 thru 42 indicate those paragraphs which will result in the purchase of a basic cooling tower—one that accomplishes the specified thermal performance, and has operation and maintenance-enhancing accessories and features that are usually desired by those persons who are responsible for the continued operation of the system of which the tower is a part. It will also incorporate those standard materials which testing and experience has proven to provide acceptable longevity in normal operating conditions.

Pages 31 thru 42 provide paragraphs intended to add those features, components and materials that will customize the tower to meet the user's requirements.

Space does not permit definition and explanation of all of the possible options that can be applied to the **NC Alpha**. We realize that you, the purchaser, must be happy with the tower's characteristics, and we are prepared to provide—or provide for—any reasonable enhancement that you are willing to define and purchase. *Your needs will become part of the continuing evolution of this Marley product line.*

The NC–Quiet by Design

The NC is the result of extensive design studies focused on cooling tower sound control. These studies were complicated by the fact that the cooling tower market is typically driven by one of two powerful, yet often conflicting requirements. The most common is for a cooling tower that provides the required heat rejection capacity with a high level of reliability at low cost. Sound control, while important, is not the primary consideration for this application.

The other requirement, which is becoming ever more important in our crowded, fast-paced society, is driven by conditions that demand the lowest practical sound level. Energy efficiency, reliability, ease of maintenance and reasonable cost, while still extremely important, are not the highest priorities

In the first case, sound is important, while in the second case it is extremely important. To best satisfy these two competing market requirements we created a multi-tiered approach, through key mechanical equipment selections, to sound control. The result is more options than any other cooling tower on the market today.

The result is a line of towers capable of meeting all but the most restrictive noise limitations—and that will react favorably to natural attenuation. Where the tower has been sized to operate within an enclosure, the enclosure itself will have a damping effect on sound. Sound also declines with distance—by about 6 dBA each time the distance doubles.

All standard NC cooling towers are equipped with low sound fans. Where noise at a critical point is likely to exceed an acceptable limit, several other options are available—listed below in ascending order of cost impact:

- The Marley "Quiet Package" includes the affordable Quiet Fan mechanical option, optimized to achieve the lowest possible sound levels while maintaining efficiency.
- A Marley Variable Speed Drive automatically minimizes the tower's noise level during periods of reduced load and/or reduced ambient temperature without sacrificing the system's ability to maintain a constant cold water temperature. This is a relatively inexpensive solution, and can pay for itself quickly in reduced energy costs. The natural nighttime reduction in wet-bulb temperature makes this a very feasible solution in most areas of the world. It also eliminates fan cycling. In combination with a Marley Quiet Package, the Marley Variable Speed Drive is capable of meeting all but the most restrictive noise limitations.
- The most extreme cases may require discharge sound attenuator sections—however, the static pressure loss imposed by discharge attenuators may necessitate an increase in tower size. Two stages of discharge attenuators supported by the tower and designed and tested for the most stringent requirements are available as an option. See page 23.

The advantage is yours. You now have the choices you need to balance your project's performance, space and cost requirements with your sound level needs for a win-win solution to your cooling system design.

Enclosures

Occasionally, cooling towers are located inside architectural enclosures for aesthetic reasons. Although NC towers adapt well to enclosures, the designer must realize the potential impact of a poorly arranged enclosure on the tower's performance and operation. The designer must take care to provide generous air inlet paths, and the tower's fan cylinder discharge height should not be lower than the elevation of the top of the enclosure. *Marley Technical Report #H-004 "External Influences on Cooling Tower Performance"* is available at spxcooling.com or from your Marley sales representative.

As suggested in the aforementioned Technical Report, it may also be advisable to specify a design wet-bulb temperature .5°C higher than normal to compensate for potential recirculation initiated by the enclosure. You'll benefit from discussing your project with your Marley sales representative.

System Cleanliness

Cooling towers are very effective air washers. Atmospheric dust able to pass through the louver openings will enter the circulating water system. Increased concentrations can intensify system maintenance by clogging screens and strainers—and smaller particulates can coat system heat transfer surfaces. In areas of low flow velocity—such as the cold water basin—sedimentary deposits can provide a breeding ground for bacteria.

In areas prone to dust and sedimentation, you should consider installing some means for keeping the cold water basin clean. Typical devices include side stream filters and a variety of filtration media.

Water Treatment

To control the buildup of dissolved solids resulting from water evaporation, as well as airborne impurities and biological contaminants including Legionella, an effective consistent water treatment program is required. Simple blowdown may be adequate to control corrosion and scale, but biological contamination can only be controlled with biocides.

An acceptable water treatment program must be compatible with the variety of materials incorporated in a cooling tower—ideally the pH of the circulating water should fall between 6.5 and 8.0. Batch feeding of chemicals directly into the cooling tower is not a good practice since localized damage to the tower is possible. Specific startup instructions and additional water quality recommendations can be found in the **NC User Manual** which accompanies the tower and also is available from your local Marley sales representative. For complete water treatment recommendations, consult a competent, qualified water treatment supplier.

Typical Applications

Splash fill has the longest history of successful use in the cooling tower industry. Its wide spacing discourages clogging, and its stout construction will withstand repeated cleaning of deposits associated with the circulating water quality. The **NC Alpha** is an ideal cooling tower for the following applications:

- Ethylene glycol content
- Particulate carry over—often found in steel mills and cement plants.
- Pulp carry over—typical of the paper industry and food processing where vacuum pumps or barometric condensers are used.
- Geothermal, salt water, petrochemical, phosphoric acid and fluorine applications.

Alternative Selections

In addition to the NC Alpha, SPX Cooling Technologies offers a full scope of products in various designs and capacities to meet the special demands of specific applications.

spxcooling.com—visit us on the web for a complete list of products, services, publications and to find your nearest sales representative.

△ CAUTION

The cooling tower must be located at such distance and direction to avoid the possibility of contaminated discharge air being drawn into building fresh air intake ducts. The purchaser should obtain the services of a Licensed Professional Engineer or Registered Architect to certify that the location of the cooling tower is in compliance with applicable air pollution, fire and clean air codes.

NC8405 NC8409

Use this data for preliminary layouts only. Obtain current drawing from your Marley sales representative.

UPDATE web-based selection software available at spcooling.com/update provides NC Alpha model recommendations based on customer's specific design requirements.

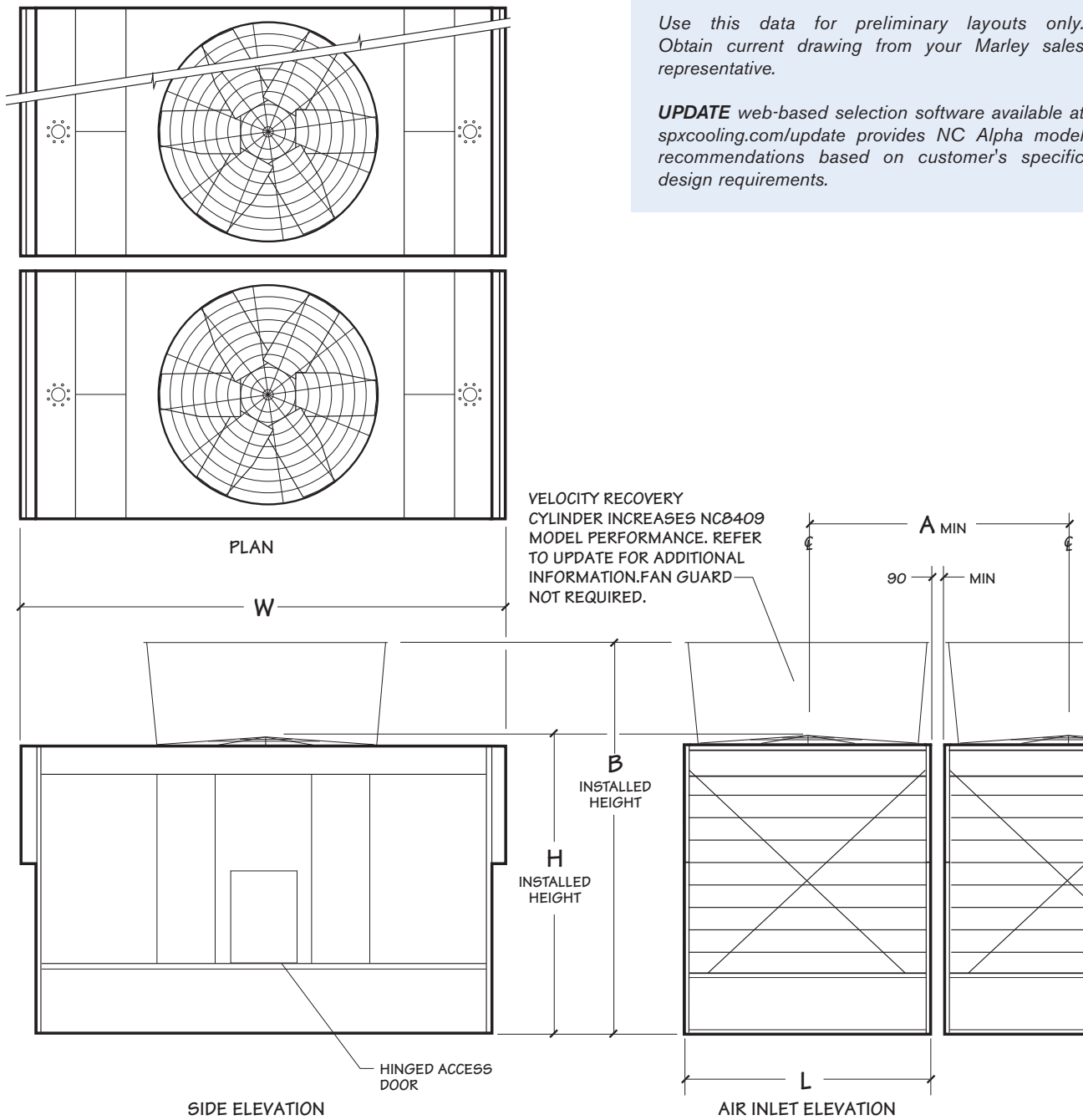

NC8405 NC8409

Model note 2	Motor kW	m ³ /hr per cell	Design Operating Weight kg	Shipping Weight kg	Dimensions				
					L	W	H	A	B
NC8405N-1	7.5	65-430	10008	5382	3016	6705	3651	3105	NA
NC8405P-1	11								
NC8405Q-1	15								
NC8405R-1	18.5								
NC8405S-1	22								
NC8405T-1	30								
NC8409P-1	11	95-615	15399	8185	4235	7468	3651	4324	5023
NC8409Q-1	15								
NC8409R-1	18.5								
NC8409S-1	22								
NC8409T-1	30								
NC8409U-1	37								
NC8409V-1	45								

A Sound dBA Approach

Various low sound options are available from 2 to 12 dB reduction. Consult **UPDATE** selection software for performance, sound levels and dimensions.

NOTE

- 1 Use this bulletin for preliminary layouts only. Obtain current drawings from your Marley sales representative. All table data is per cell.
- 2 Last numeral of model number indicates number of cells. Change as appropriate for your selection.
- 3 Standard overflow is a 4" dia. standpipe in the collection basin floor. The standpipe removes for flush-out and draining. See page 18 for side overflow option.
- 4 Outlet sizes vary according to m³/hr and arrangement. See pages 18 and 19 for outlet sizes and details.
- 5 Makeup water connection may be 1" or 2" dia., depending upon tower heat load, water pressure, and desired connections. See page 13 for additional information.

NC8411 NC8412

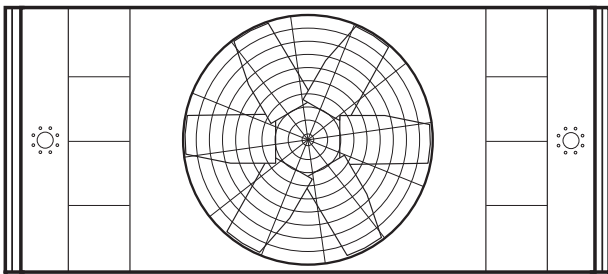
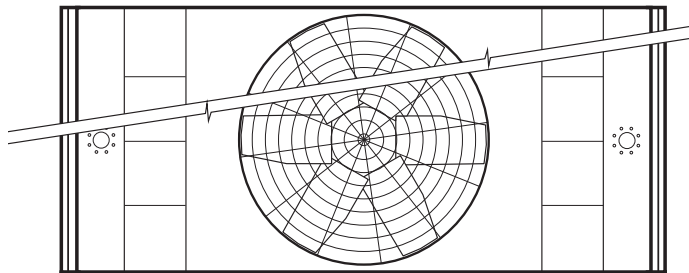

PLAN

7442

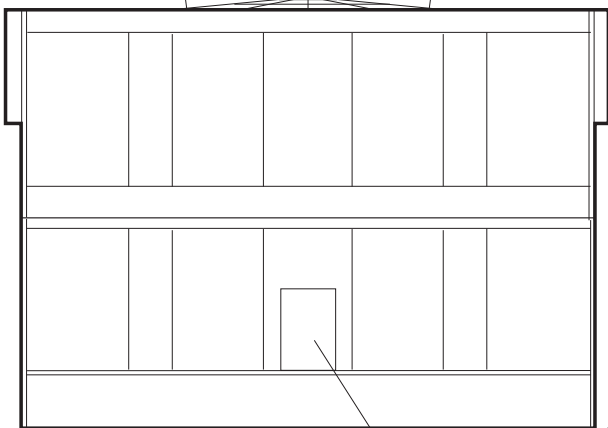

SIDE ELEVATION

HINGED ACCESS DOOR

712
INSTALLED
HEIGHT

5740
INSTALLED
HEIGHT

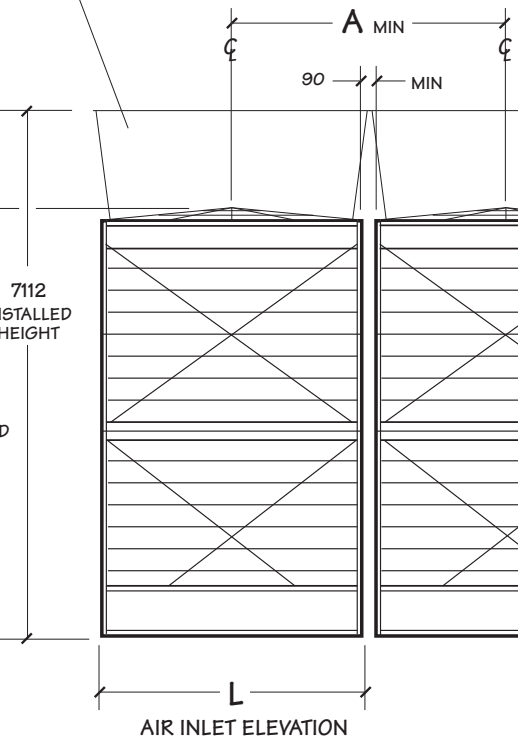

AIR INLET ELEVATION

Use this data for preliminary layouts only. Obtain current drawing from your Marley sales representative.

UPDATE web-based selection software available at spxcolling.com/update provides NC Alpha model recommendations based on customer's specific design requirements.

VELOCITY RECOVERY CYLINDER INCREASES MODEL PERFORMANCE. REFER TO UPDATE FOR ADDITIONAL INFORMATION. FAN GUARD NOT REQUIRED.

NC8411 NC8412

Model note 2	Motor kW	m ³ /hr per cell	Design Operating Weight kg	Shipping Weight kg	Dimensions	
					L	A
NC8411Q-1	15	80-522	18658	10977	3626	3715
NC8411R-1	18.5					
NC8411S-1	22					
NC8411T-1	30					
NC8411U-1	37					
NC8411V-1	45					
NC8412Q-1	15	94-613	21396	12379	4235	4324
NC8412R-1	18.5					
NC8412S-1	22					
NC8412T-1	30					
NC8412U-1	37					
NC8412V-1	45					
NC8412W-1	55					

A Sound dBA Approach

Various low sound options are available from 2 to 12 dB reduction. Consult **UPDATE** selection software for performance, sound levels and dimensions.

NOTE

- 1 Use this bulletin for preliminary layouts only. Obtain current drawings from your Marley sales representative. All table data is per cell.
- 2 Last numeral of model number indicates number of cells. Change as appropriate for your selection.
- 3 Standard overflow is a 4" dia. standpipe in the collection basin floor. The standpipe removes for flush-out and draining. See page 18 for side overflow option.
- 4 Outlet sizes vary according to m³/hr and arrangement. See pages 18 and 19 for outlet sizes and details.
- 5 Makeup water connection may be 1" or 2" dia., depending upon tower heat load, water pressure, and desired connections. See page 13 for additional information.

Tired of having to design your piping and tower layout to accommodate the standards of cooling tower manufacturers? Marley's multiple variety of piping systems accommodates your design intentions to make your layout of the NC Alpha both expedient and economical.

- Single or dual hot water inlet connections.
- Side inlet or top inlet connections.
- Side or bottom cold water outlet connections.
- A variety of makeup, overflow and drain options.

For the single inlet connection all piping to the distribution basins is part of the tower package. Installation and design costs are reduced and the need for extra piping and supports are eliminated.

Unless otherwise specified, single-cell towers normally have a cased-face outlet appropriate for the design water flow rate—see pages 18 and 19. This usually assures the lowest possible installed tower elevation. Cased-face outlet connection pipes extend approximately 75mm outside the basin, and are beveled for weld connection and also grooved for a mechanical coupling.

Outlet piping can be kept below the cold water basin level by choosing either a depressed sump or a bottom outlet connection in lieu of the cased-face outlets. Both outlet designs are available to conform to customers flange specifications. Easily removable debris screens are optional on bottom outlets and are standard on all other outlet arrangements.

Depressed sumps are made of inert fire-retardant FRP or heavy-gauge welded hot dip galvanized or stainless steel. Unless otherwise specified towers with stainless steel basins are supplied with stainless sumps and towers with galvanized steel collection basins are supplied with FRP sumps. Galvanized steel collection basins can also be supplied with hot dip galvanized sumps.

Multicell towers, intended to operate together as a common unit, are joined by steel flumes between the collection basins. These flumes equalize the operating water level between basins and also provide a flow passage from cells not equipped with outlets or makeup valves, often eliminating the need to specify an outlet and makeup valve for each cell on a multicell installation. Select the number of outlets required to maintain a maximum flow of 310 m³/hr through each flume for the NC8405 models and 500 m³/hr for NC8409 through NC8412 models. Flow values are for cased-face outlet or bottom-outlets without trash screen. Refer to NC sales drawings to obtain flow values for sumps and bottom outlets with trash screens.

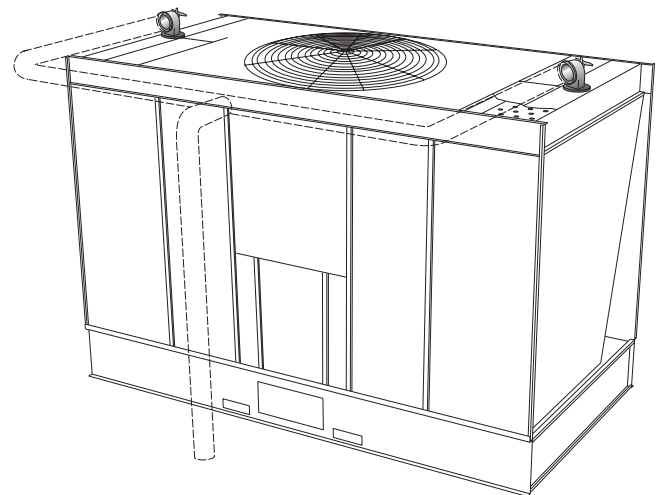
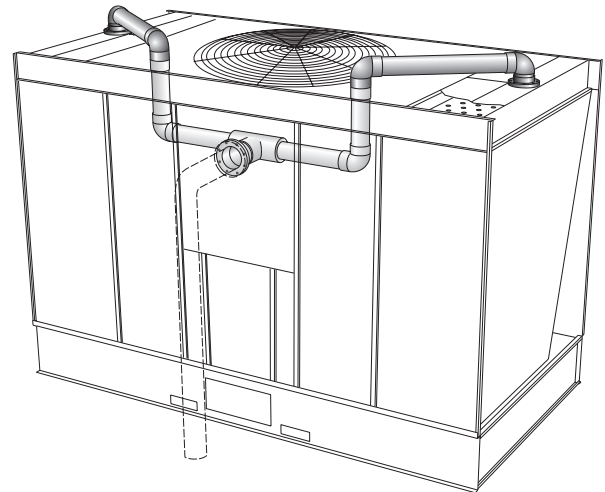

If each cell is to be equipped with an outlet, cased-face outlets can be used on end cells of multicell towers, but a cased-face outlet cannot be used on interior cells. For direct outlet from each cell on installations of three or more cells, use either the depressed sump or bottom outlet on interior cells.

The best choice for a tower used with a remote or indoor storage tank—see page 22—or on a concrete cold water basin is usually a bottom outlet.

A cased-face outlet equipped tower can be installed on a flat concrete slab if a side drain and overflow are also specified—see page 18. Consult your Marley sales representative for complete information.

Makeup

The amount of water constantly evaporated from a cooling tower varies directly with the heat load applied. In addition to evaporation, water is normally lost to the blowdown (bleed-off) necessary to maintain dissolved solids concentration at an acceptable level in the circulating water system.

The NC Alpha is equipped with one or more float-operated, mechanical makeup valves to automatically replenish this lost water. The tables on this page, calculated for a concentration of 3 times normal, indicate the rate of water loss—and the size of valve(s) required. If your installation’s cold water basin will drain by gravity to a remote storage tank—or if you plan a separate means of controlling makeup water—a price reduction is available for deleting the Marley valve(s). We also offer an optional electronic liquid-level control.

In most instances cooling towers will see the highest water usage at design heat load. Off design conditions (99% of the time) water usage will be less. For a better understanding of how much water your application will use throughout the year, consult our water usage calculator at:

spxcooling.com/watercalc

If too much water is still being consumed consult your Marley sales representative for water saving alternatives.

Makeup Water Flow Required – m ³ /hr to Maintain Three (3) Concentrations						
Tower m ³ /hr	Cooling “Range” (hot water minus cold water)					
	3°C	6°C	8°C	12°C	17°C	24°C
45	.5	.7	.9	1	2	2
91	.7	1	2	2	3	5
136	.9	2	3	3	5	7
182	1	2	3	5	7	9
227	2	3	4	6	9	11
341	2	4	7	9	13	17
454	3	6	9	11	17	23
681	4	9	13	17	26	34
908	6	11	17	23	34	45
1135	7	14	21	28	43	57
1362	9	17	26	34	51	68
1816	11	23	34	45	68	91

NOTE

If circulating water is to be maintained at 2 concentrations instead of 3, multiply table m³/hr values by 1.36 before sizing makeup valve.

Makeup Valve Flow Capacities – m ³ /hr		
Pressure at Valve Inlet while flowing–kPa	1" Diameter Valve	2" Diameter Valve
69	13	20
138	18	27
207	21	33
276	24	36
345	27	38

NOTE

- If makeup water pressure exceeds 345 kPa, use pressure reducer ahead of valve.
- For flow requirements exceeding the above limitations, use multiples of the same size valve.

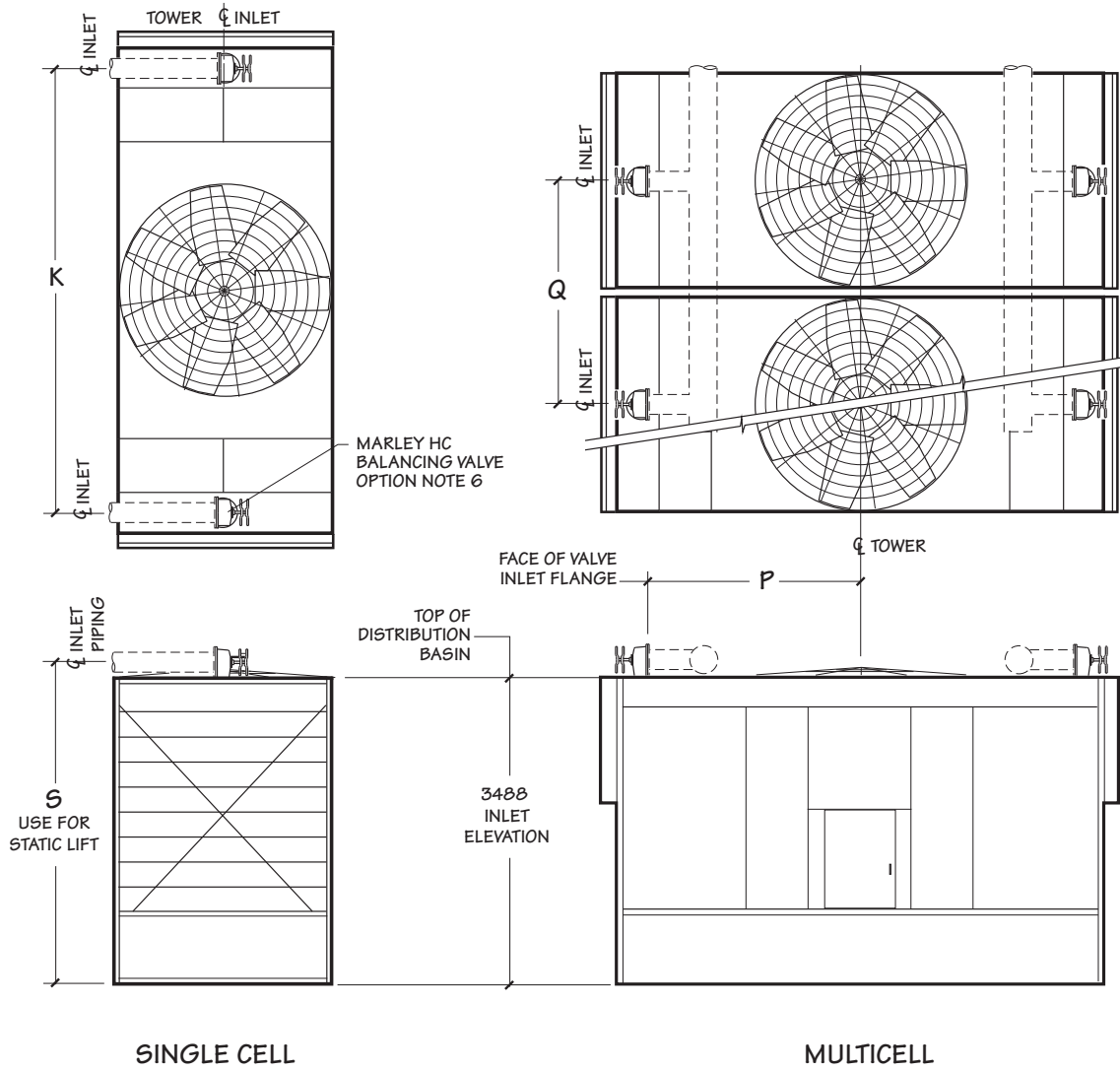

Model	Dimensions					Fan Diameter	Inlet Diameter
	J	K	S	P	Q		
NC8405	3488	5423	3720	2623	3112	108"	2 at 8"
NC8409	3488	6185	3770	2985	4324	144"	2 at 10"

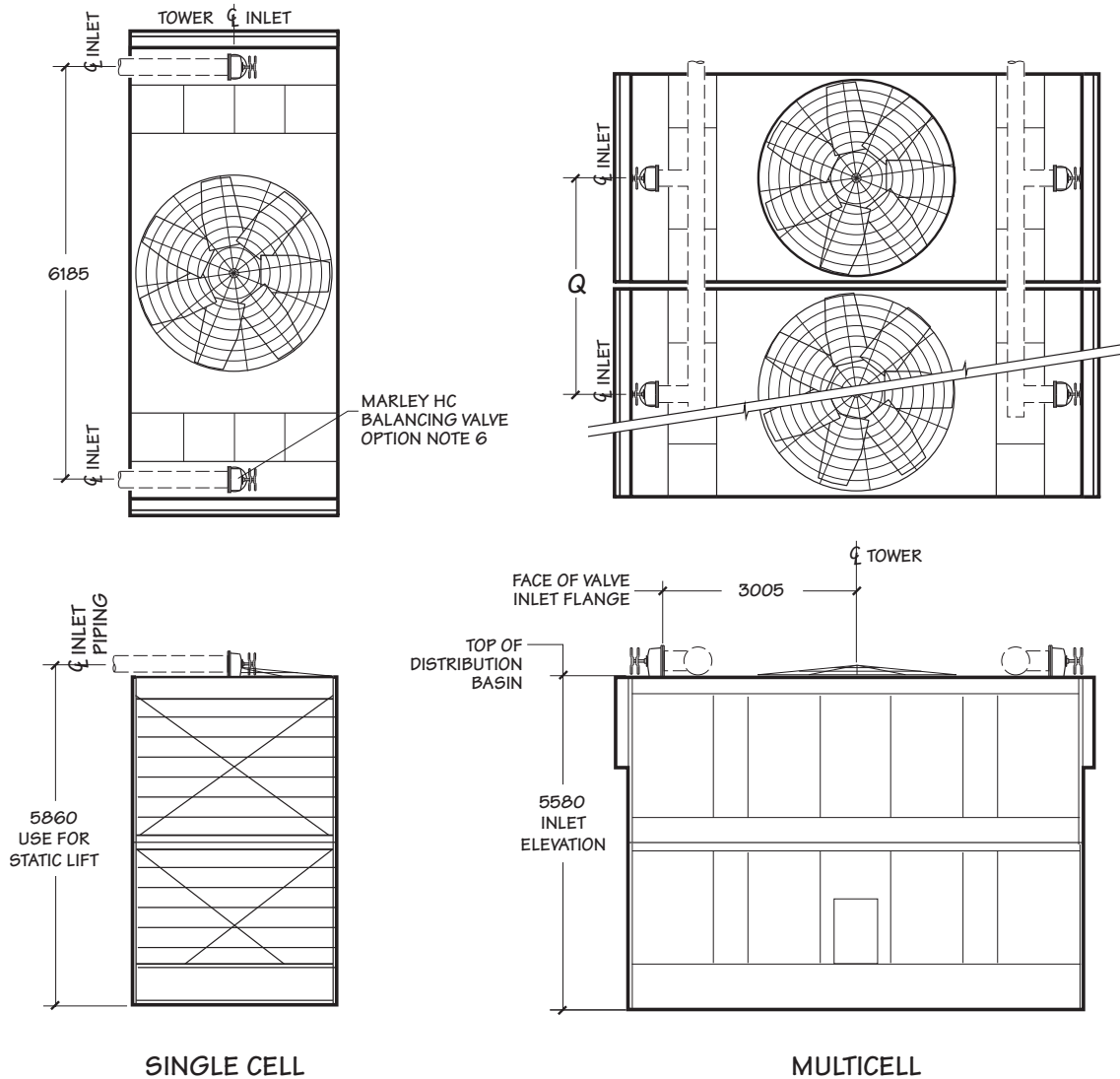

Model	Dimensions	Fan Diameter	Inlet Diameter
	Q		
NC8411	3715	132"	2 at 10"
NC8412	4324	144"	2 at 10"

NOTE

- 1 Use this bulletin for preliminary layouts only. Obtain current drawings from your Marley sales representative.
- 2 Pumping head contributed by the tower is static lift "S". Add your system dynamic pipe losses for total.
- 3 The tower will support the vertical weight of piping shown within the plan area of the tower only. All piping loads, including thrust and lateral loads of riser and horizontal piping must be supported independent of the tower. See inlet piping drawings for details.
- 4 All piping and supports—and their design—are by others.
- 5 Allow adequate clearance for entry to tower access doors and safe use of optional ladder. Refer to appropriate Marley drawings.
- 6 You may choose to use 90° short radius flanged elbows in place of HC balancing valves on single-cell towers where inlet piping is balanced for equal flow. Pipe elevation remains as shown.

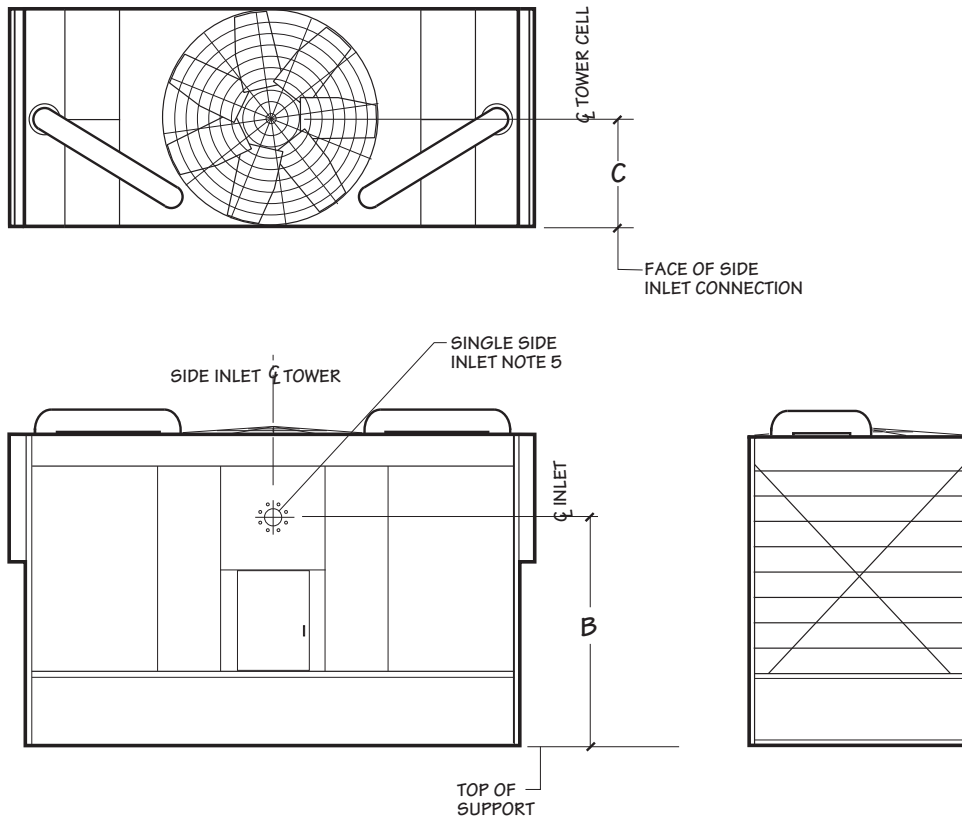

Model	Dimensions		Inlet Diameter
	B	C	
NC8405	2808	1826	10"
NC8409	2797	2438	10"

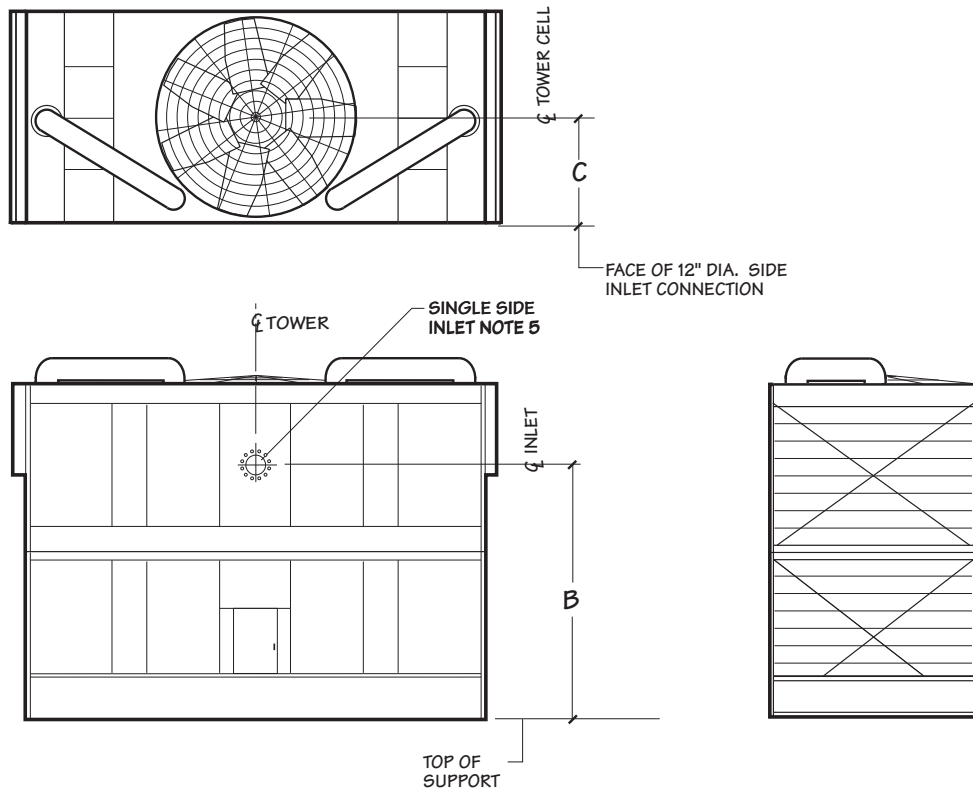

Model	Dimensions	
	B	C
NC8411	4915	2221
NC8412	4915	2502

NOTE

- 1 Use this bulletin for preliminary layouts only. Obtain current drawings from your Marley sales representative.
- 2 All external piping loads, including weight, thrust and lateral loads of riser and horizontal piping plus the weight of water in the internal riser must be supported independent of the tower. Internal riser adds additional vertical operating loads to external piping at the bottom inlet flange.
- 3 All piping and supports beyond the inlet connection—and their design—are by others.
- 4 Allow adequate clearance for entry to tower access doors and safe use of optional ladder. Refer to appropriate Marley drawings.
- 5 Contact your Marley sales representative for the required pump head for single-inlet applications.
6. Weight of internal piping must be added to tower weights. Contact your Marley sales representative for combined tower weight information.

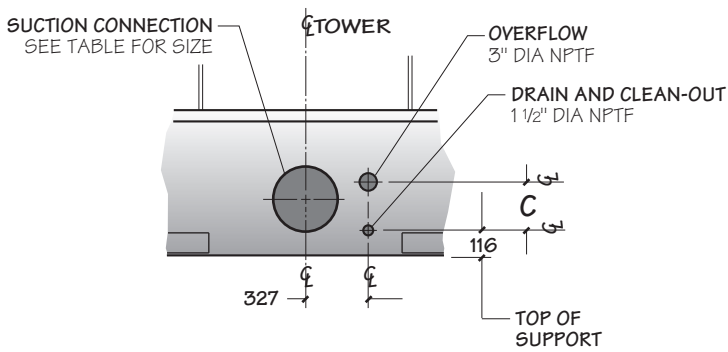

Model	Dimensions		
	A	B	C
NC8405	286	1534	259
NC8409	286	2143	259
NC8411	286	1838	303
NC8412	286	2143	303

DRAIN AND OVERFLOW CONNECTION
OPTION

NOTE
Standard overflow is a 4" dia. standpipe in the collection basin floor.
The standpipe removes for flush-out and draining.

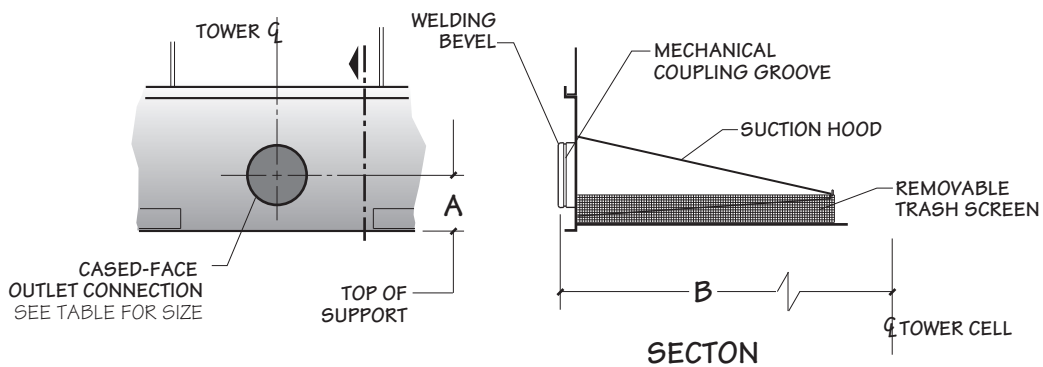

CASED-FACE OUTLET CONNECTION

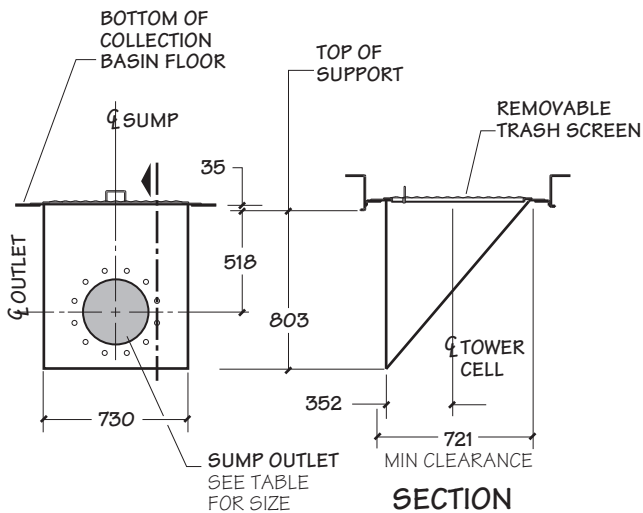

**DEPRESSED SIDE-OUTLET
SUMP CONNECTION**
STAINLESS STEEL OR FRP

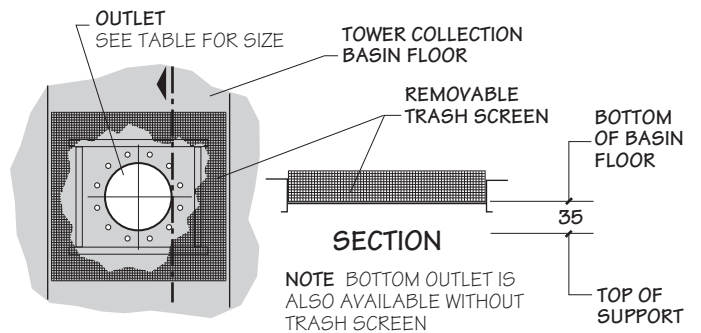

BOTTOM OUTLET CONNECTION

Maximum Flow Per Outlet Diameter												
m ³ /hr												
Outlet Type	Flow Type	Model	Outlet Diameter									
			4"	6"	8"	10"	12"	14"	16"	18"	20"	24"
Bottom	pump flow w/ anti-vortex plate or gravity flow w/ or w/o anti-vortex plate	NC8405	36	81	143	226	321	393	519	570	755	913
		NC8409 thru NC8412	38	86	153	241	343	420	555	719	870	1112
	pump flow w/o anti-vortex plate	NC8405 thru NC8412	16	37	65	103	146	179	237	306	381	553
Sump	pump flow w/ anti-vortex plate or gravity flow w/ or w/o anti-vortex plate	NC8405		204	362	571	813	973				
		NC8409 thru NC8412		204	362	571	813	995				
	pump flow w/o anti-vortex plate	NC8405 thru NC8412		143	254	400	569	696				
Cased-Face Outlet	pump flow only	NC8405		204	362	571	813					
		NC8409 thru NC8412		204	362	571	813	995				

NOTE

- Flow rate may be limited by the maximum m³/hr for unit size.
- For gravity-flow situations (as to an indoor tank), use bottom outlet or depressed side outlet sump. Cased-face outlet is not recommended for gravity flow.
- m³/hr limits are the outlet capacities per outlet based on the design operating water level—216mm above the top of support on NC8405 models—241mm on NC8409 thru NC8412.

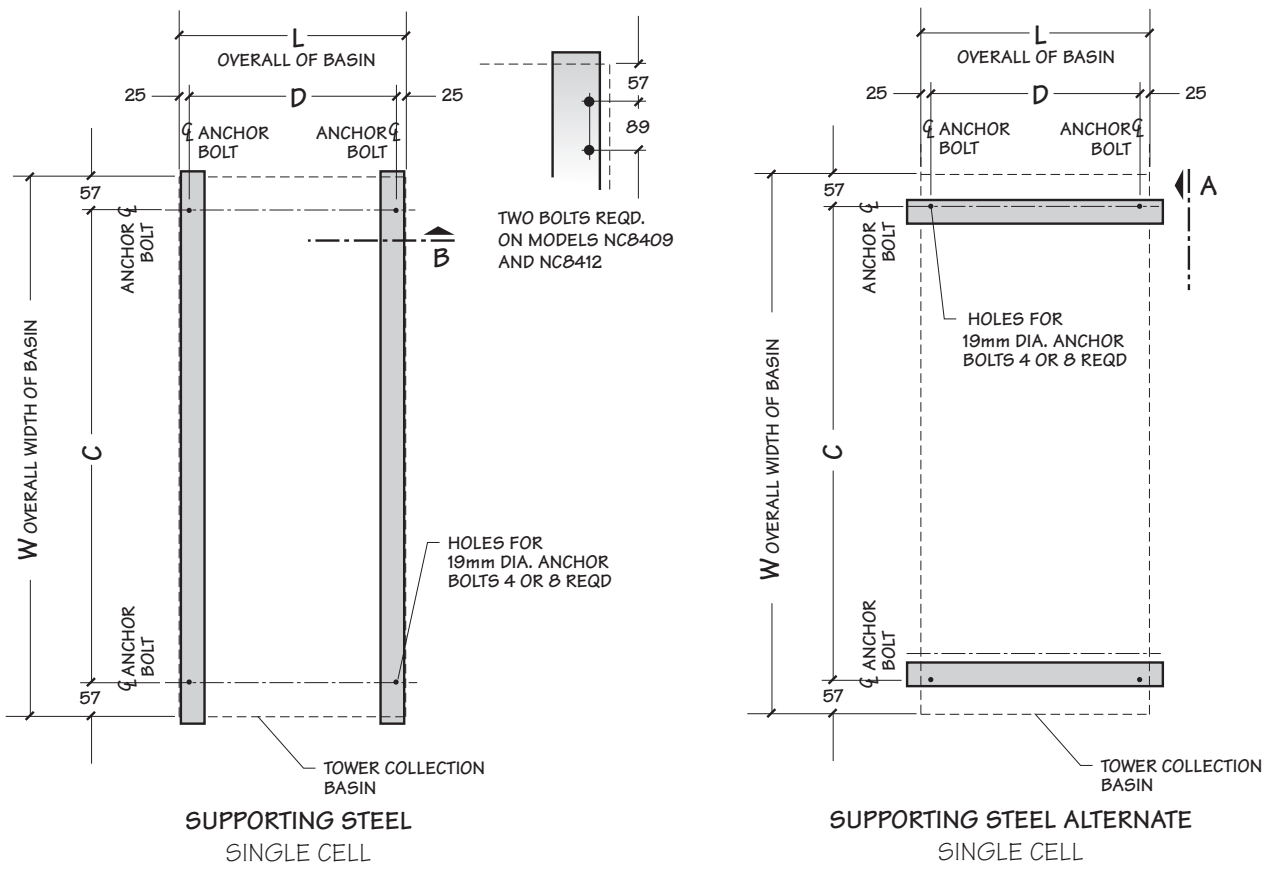

Model	Dimensions				Maximum Shutdown Weight/Cell kg	Design Operating Load at Anchor kg	Wind p and Seismic g Loads kgf note 4			
	W	L	C	D			Max Vertical Reaction at Anchor		Max Horizontal Reaction at Anchor	
NC8405	6071	3016	5956	2965	10708	2677	6.92 x P	2878 x G	5.87 x P	2676 x G
NC8409	6833	4235	6718	4185	16466	4116	5.46 x P	2722 x G	6.54 x P	4115 x G
NC8411	6833	3626	6718	3575	20660	5165	16.33 x P	7329 x G	10.44 x P	5164 x G
NC8412	6833	4235	6718	4185	23641	5910	13.95 x P	7151 x G	10.44 x P	5909 x G
NC Models with Velocity Recovery Cylinder										
NC8409	6833	4235	6718	4185	16600	4150	6.88 x P	2821 x G	7.23 x P	4149 x G
NC8411	6833	3626	6718	3575	20677	5169	18.60 x P	7398 x G	11.08 x P	5168 x G
NC8412	6833	4235	6718	4185	23775	5944	16.06 x P	7235 x G	11.14 x P	5942 x G

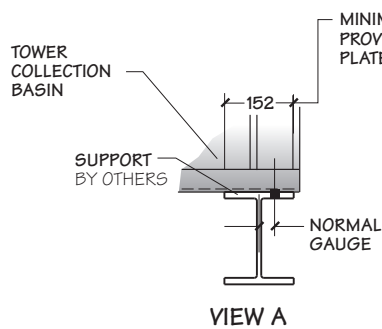
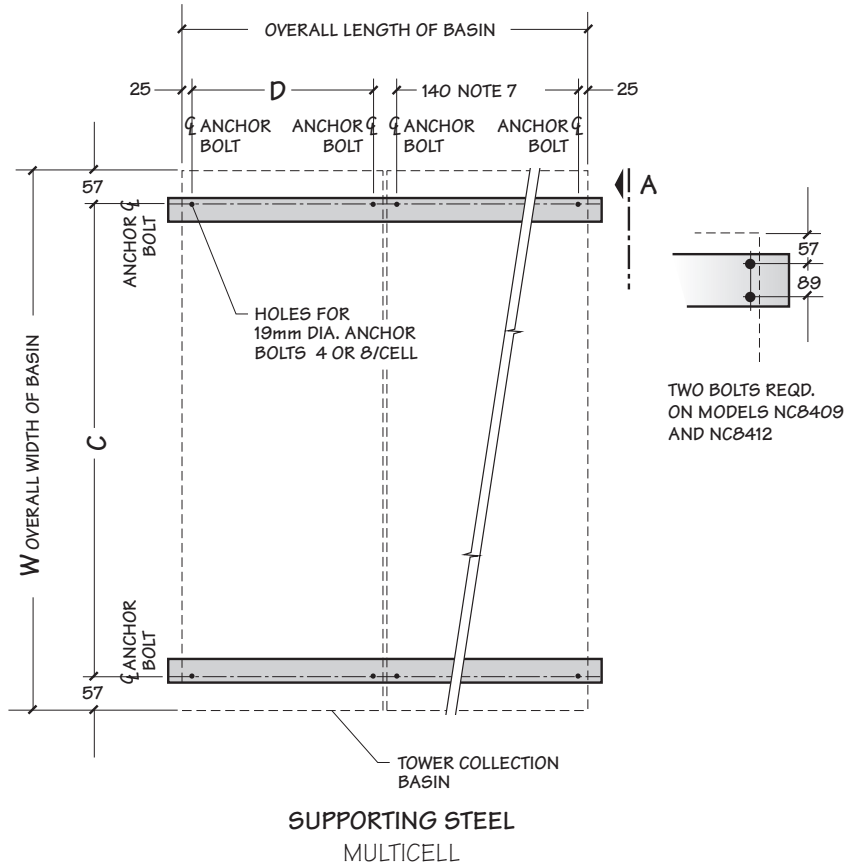

MINIMUM BEARING WIDTH MUST BE PROVIDED BY BEAM FLANGE OR BEARING PLATE AT EACH ANCHOR BOLT LOCATION.

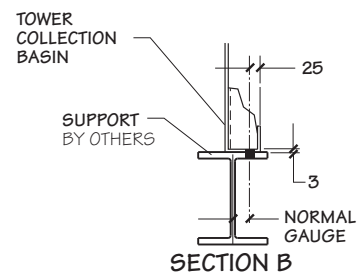

NOTE

- 1 Use this bulletin for preliminary layouts only. Obtain current drawings from your Marley sales representative for final design.
- 2 Purchaser to provide tower support complete with holes and anchor bolts. Do not use studs! Anchor points must be framed flush and level at top.
- 3 Design operating weight occurs with collection basin full to overflow level. Actual operating weight varies with m^3/hr and piping scheme.
- 4 Wind reactions can be calculated by multiplying by p , which is the wind pressure in psf. Seismic reactions can be calculated by design g . Wind loads are additive to operating loads.
- 5 Tower may be placed on a flat concrete slab. Side outlet and optional side drain and overflow must be specified. See pages 13 and 18 and consult your Marley sales representative.
- 6 Tower may be supported from piers at each anchor bolt location, as a support alternative.
7. Dimensions between anchor bolts may vary depending on the number of cells and options. Dimensions shown are for a standard two cell arrangement. Obtain current drawings from your Marley sales representative for final dimension.

When the ambient air temperature falls below 0°C, the water in a cooling tower can freeze. *Marley Technical Report #H-003 “Operating Cooling Towers in Freezing Weather”* describes how to prevent freezing during operation. Available at spxcooling.com or ask your Marley sales representative for a copy.

During shutdown, water collects in the cold water basin and may freeze solid. You can prevent freezing by adding heat to the water left in the tower—or, you can drain the tower and all exposed pipework at shutdown.

Electric Basin Heaters

An automatic basin water heater system is available consisting of the following components:

- Stainless steel electric immersion heater(s).
 - Threaded couplings are provided in the side of the collection basin.
 - IP56 enclosure containing:
 - Magnetic contactor to energize heater.
 - Transformer to convert power supply to 24 volts for control circuit.
 - Solid state circuit board for temperature and low-water cutoff.
- Enclosure may be mounted on the side of the tower.
- Control probe in the collection basin to monitor water temperature and level.

Heater components are normally shipped separately for installation by others.

Note: any exposed piping that is still filled with water at shutdown—including the makeup water line—should be electrically traced and insulated (by others).

Steam Jet Basin Heaters

Penberthy Houdaille bronze steam jet heaters (6mm to 19mm) are available for freeze protection (installation by others). Injectors install in a coupling provided in the side of the collection basin. Live steam, as required, is injected directly into the water. Condensed steam adds water to the basin, and the excess will exit the overflow of the tower.

Indoor Storage Tank

With this type of system, water flows from an indoor tank, through the load system, and back to the tower, where it is cooled. The cooled water flows by gravity from the tower to the tank located in a heated space. At shutdown, all exposed water drains into the tank, where it is safe from freezing.

The table on page 22 lists typical drain-down capacities for all NC tower models. Although we do not produce tanks, many of our representatives offer tanks supplied by reputable manufacturers.

The amount of water needed to successfully operate the system depends on the tower size and m³/hr and on the volume of water contained in the piping system to and from the tower. You must select a tank large enough to contain those combined volumes—plus a level sufficient to maintain a flooded suction on your pump. Control makeup water according to the level where the tank stabilizes during operation.

NC Drain-Down Capacity					
Model	Range of Tower Design m ³ /hr	Drain Down Maximum Liters	Model	Range of Tower Design m ³ /hr	Drain Down Maximum Liters
NC8405	66-139	2941	NC8411	80-168	5152
	141-213	3407		170-259	5954
	216-288	4005		261-350	6189
	291-363	4221		352-441	6609
	366-432	4315		443-522	7696
NC8409	94-195	5243	NC8412	94-195	6007
	198-300	5890		198-300	6931
	302-404	5966		302-404	7200
	407-509	6197		407-509	7650
	511-613	7226		511-613	9036

NOTE

Volumes shown are maximums for the m³/hr ranges indicated. Actual volumes will usually be less. Contact your Marley sales representative for more specific information.

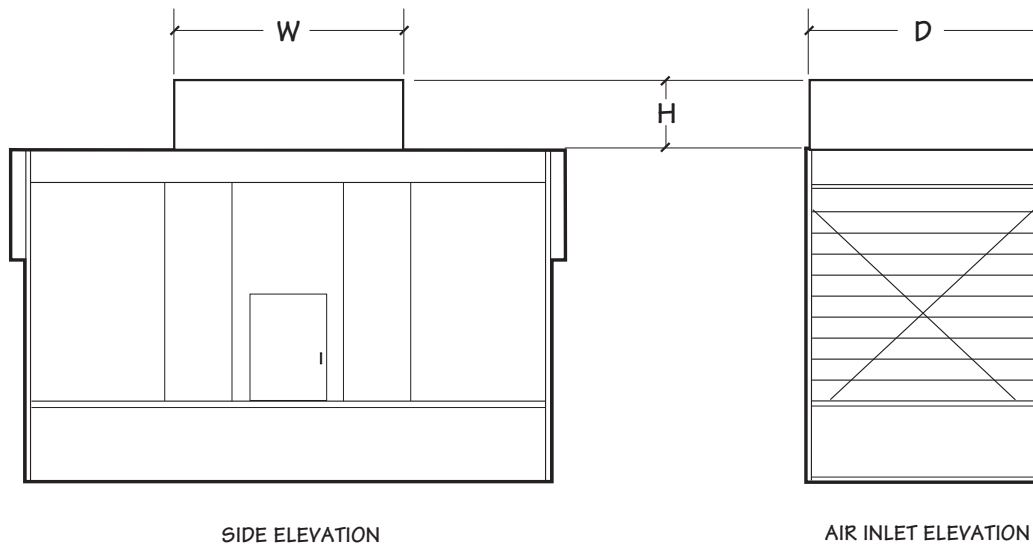

Model	Dimensions			Add To Design Operating Weight kg
	W	D	H	
NC8405	2972	2896	686	477
	2972	2896	1372	953
NC8409	3896	4115	686	733
	3896	4115	1372	1466
NC8411	3578	3505	686	709
	3578	3505	1372	1419
NC8412	3896	4115	686	733
	3896	4115	1372	1466

NOTE

- 1 **Use this bulletin for preliminary layouts only.** Obtain current drawings from your Marley sales representative. All table data is per cell.
- 2 Attenuators are field installed by others with hardware provided by Marley
- 3 Attenuators are supported by the tower. Additional support not required.
- 4 Discharge attenuators are not available for NC models with velocity recovery cylinders.

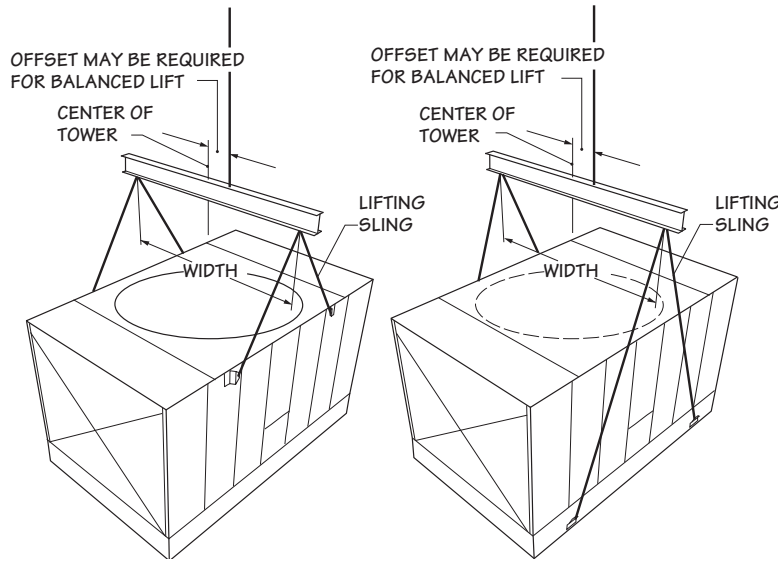

Model	Width	Minimum Sling Length
NC8405	3048	2438
NC8409	4267	5486
NC8411 Top	3658	2743
NC8411 Bottom	3658	5486
NC8412 Top	4267	2743
NC8412 Bottom	4267	5486

NOTE

- All hoisting clip holes are 32mm.
- On multicell tower installations, overall length of shackle pins should not exceed 133mm.
- For overhead lifts or where additional safety is required, add slings beneath the tower unit.

Specifications	Specification Value
<p>1.0 Base:</p> <p>1.1 Provide an induced draft, crossflow type, factory assembled, splash fill, industrial duty, galvanized steel cooling tower situated as shown on the plans. The limiting overall dimensions of the tower shall be _____ wide, _____ long, and _____ high. Total operating horsepower of all fans shall not exceed _____ kW, consisting of _____ @ _____ kW motor(s). Tower shall be similar and equal in all respects to Marley Model _____.</p>	<p>■ Your specification base establishes the type, configuration, base material, and physical limitations of the cooling tower to be quoted. During the planning and layout stages of your project, you will have focused your attention on a cooling tower selection that fits your space allotment, and whose power usage is acceptable. Limitations on physical size and total operating horsepower avoid the introduction of unforeseen operational and site-related influences. Specifying the number of cells, and the maximum fan kW/cell will work to your advantage.</p> <p>Crossflow towers are noted for the accessibility and maintainability of all operating components. The spacious interior provides easy access to fill, drift eliminators, all basin accessories—and is one of two primary access ways to the fan, Geareducer[®], and other mechanical components.</p> <p>At the fan deck level, the hot water distribution basins are easily inspected and cleaned—while the tower is operating, if you wish.</p> <p>Except for the cold water basin, no counterflow tower component requiring routine maintenance is as easily accessed. The confined areas that typify counterflow designs can make difficult work for maintenance personnel!</p> <p>The NC Alpha is also available unassembled for on-site assembly.</p>



Specifications	Specification Value
<p>2.0 Thermal Performance and Efficiency:</p> <p>2.1 The tower shall be capable of cooling _____ m³/hr of water from _____ °C to _____ °C at a design entering air wet-bulb temperature of _____ °C. The cooling tower manufacturer shall guarantee that the tower supplied will meet the specified performance conditions when the tower is installed according to plans. If, because of a suspected thermal performance deficiency, the owner chooses to conduct an on-site thermal performance test in the presence of the manufacturer, and under the supervision of a qualified, disinterested third party in accordance with CTI (Cooling Tower Institute) test code ATC-105 standards during the first year of operation; and if the tower fails to perform within the limits of test tolerance; then the cooling tower manufacturer shall make alterations as it deems necessary to overcome indicated deficiency. Should alterations prove to be inadequate, the owner, at the cooling tower manufacturer's option, shall be compensated by either (or a combination of both) of the following: (a) Installation of additional cooling tower capacity; (b) A refund of a percentage of the contract price proportional to the deficiency as established.</p> <p>4.0 Design Loading:</p> <p>4.1 The tower structure, anchorage and all its components shall be designed by licensed structural engineers per the International Building Code to withstand a wind load of 146.5 kg/m², as well as a .3g seismic load. The fan deck and hot water basin covers shall be designed for 2.4kPa live load or a 91kg concentrated load. Guardrails, where specified, shall be capable of withstanding a 890N concentrated live load in any direction, and shall be designed in accordance with OSHA guidelines.</p>	<p>■ Some manufacturers resist the need to guarantee the capability of their offering because of blanket certification of their product line by the Cooling Tower Institute. However, CTI certification of a tower's thermal performance is insufficient to assure you that the tower will perform satisfactorily in your situation. Certification is established under relatively controlled conditions, and towers seldom operate under such ideal circumstances. They are affected by nearby structures, machinery, enclosures, effluent from other towers, etc. Responsible and knowledgeable bidders will take such site-specific effects into consideration in selecting the tower—but the specifier must insist by the written specification that the designer/manufacturer guarantee this "real world" performance. <i>Any reluctance on the part of the bidder should cause you some concern.</i></p> <p>■ It is important to understand the distinction between structure and anchorage. Specifying that only the anchorage meet these requirements means the tower can become non-functional, even fall down, yet remain attached to the foundation. Specifying structure will require the tower to remain operational. The indicated design values are the minimums allowed under accepted design standards. They give you assurance that the tower can be shipped, handled, hoisted—and ultimately operated in a normal cooling tower environment. Most NC Alpha models will withstand significantly higher wind and seismic loads. If your geographic location dictates higher wind load or seismic load values, please make the appropriate changes, after discussion with your Marley sales representative.</p> <p>Some countries and states, like Florida, require structure and anchorage to meet a given loading. Check with your local officials.</p> <p>146.5 kg/m² windload, .3g seismic load—applicable for most applications but consult the local code official for actual requirements. 2.4kPa live load, 890N concentrated load—ensures the tower can be safely accessed for routine maintenance when a guardrail is installed as well ensuring the end user complies with government safety laws.</p>

Specifications	Specification Value
<p>5.0 Construction:</p> <p>5.1 Except where otherwise specified, all components of the cooling tower shall be fabricated of heavy-gauge steel, protected against corrosion by G-235 galvanizing. The tower shall be capable of withstanding water having a pH of 6.5 to 8.0; a chloride content (NaCl) up to 300 mg/L; a sulfate content (SO₄) up to 250 mg/L; a calcium content (CaCO₃) up to 500 mg/L; silica (SiO₂) up to 150 mg/L; and design hot water temperatures up to 52°C.</p> <p>5.2 The specifications, as written, are intended to indicate those materials that will be capable of withstanding the above water quality in continuing service, as well as the loads described in paragraph 4.1. They are to be regarded as minimum requirements. Where component materials peculiar to individual tower designs are not specified, the manufacturers shall take the above water quality and load carrying capabilities into account in the selection of their materials of manufacture.</p> <p>6.0 Mechanical Equipment:</p> <p>6.1 Fan(s) shall be propeller-type, incorporating wide-chord aluminum alloy blades and galvanized hubs. Blades shall be individually adjustable. Maximum fan tip speed shall be 66 m/s Fan(s) shall be driven through a right angle, industrial duty, oil lubricated, geared speed reducer that requires no oil changes for the first five (5) years of operation. The gearbox bearings shall be rated at an L_{10A} service life of 100,000 hours or greater.</p> <p>6.1 (alternate)* Fan(s) shall be propeller-type, incorporating wide-chord aluminum alloy blades and galvanized hubs. Blades shall be individually adjustable. Fan(s) shall be driven through a one-piece multi-groove, solid back V-type belt, pulleys and tapered roller bearings. Bearings shall be rated at an L_{10A} service life of 40,000 hours or greater. *Currently available on NC Alpha models up to 45kW.</p>	<p>■ In the history of cooling towers, no other coating for carbon steel has exhibited the success and longevity of galvanization in exposure to the normal cooling tower water quality defined at left. No paints, electrostatically-applied coatings or rubberized compounds, however exotic they may be, can approach galvanization's history of success.</p> <p>Except for those unusual operating situations where the circulating water may be so laden with suspended solids, algae, fatty acids, product fibers, active organisms reflected in BOD, and the like that plugging of the fill is a probability, reasonable attention to the construction materials and/or their coatings is all that is normally required.</p> <p>If extended longevity of the tower is required—or unusually harsh operating conditions are expected—consider specifying stainless steel as either the base construction material, or the material utilized for specific components of your choice. See Stainless Steel Options on page 31.</p> <p>■ Propeller-type fans require only half the operating kW of blower-type fans. However, they should be readily adjustable to permit compensation for job-site conditions.</p> <p>With NC Alpha, the choice is yours. The exclusive Marley System5 Geareducer® requires no oil changes for five years, offering you unmatched reliability and low maintenance. Ideal for owners concerned about downtime or maintenance costs. Currently available on NC Alpha models up to 45kW, the Marley Power Belt drive system features all-aluminum sheaves, power band belts and long-life bearings for dependable service.</p> <p>TEFC motors offer additional benefits over TEAO motors whose only source of cooling is the flow of air produced by the cooling tower fan. This air rate is not always ideal due to motor position, blockage, etc. TEFC ensures the motor will always be cooled properly.</p> <p>Unless otherwise specified, motor speed will be 1800 RPM in 60 Hertz areas and 1500 RPM in 50 Hertz areas on standard models. Low sound models will use motor speeds appropriate for the specific model. If you prefer the operating flexibility of two-speed operation, please specify two-speed, single-winding or double-winding motors which offer full and half speeds for maximum energy savings. Incidentally, two speed, double-winding motors are a better choice than separate “pony” motors which simply double the problems indicated above and induce parasitic loads during operation for lower than nameplate efficiency.</p>

Specifications

Specification Value

6.2 Motor(s) shall be ____ kW maximum, TEFC, 1.15 service factor, variable torque, and specially insulated for cooling tower duty. Speed and electrical characteristics shall be _____ RPM, single-winding, ____ phase, ____ hertz, ____ volts. Motor shall operate in the shaft-horizontal position, and nameplate horsepower shall not be exceeded at design operation.

The value of a 5 year mechanical equipment warranty speaks for itself. Except for the motor, virtually all of the mechanical equipment on a Marley tower is designed and manufactured by SPX Cooling Technologies. Cooling tower vendors who purchase commercial fans, gear reducers, driveshafts, etc. may require that you deal directly with those commercial suppliers for warranty satisfaction.

6.3 The complete mechanical equipment assembly for each cell shall be supported by a rigid steel structural support that resists misalignment between the motor and the gear reducer. The mechanical equipment assembly shall be warranted against any failure caused by defects in materials and workmanship for no less than five (5) years following the date of tower shipment. This warranty shall cover the fan, speed reducer, drive shaft and couplings, and the mechanical equipment support. The electric motor shall carry a manufacturer's warranty of at least one year.

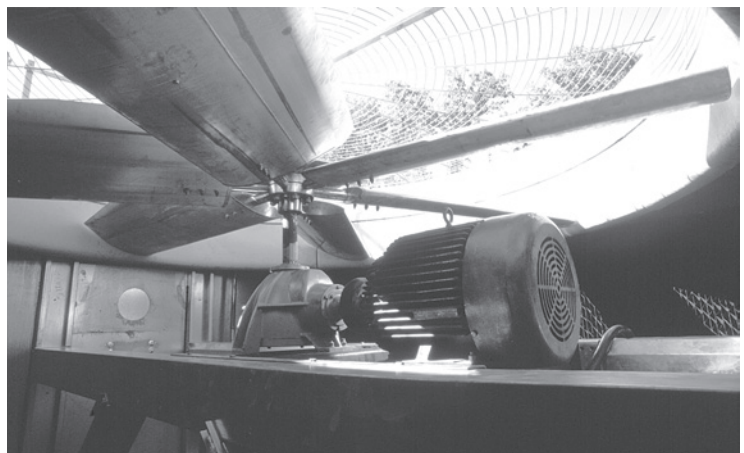

7.0 Fill, Drift Eliminators and Louvers:

7.1 Fill shall be a splash-type, non-clogging design. Splash bars shall be hollow, extruded, structural bars of PVC, a minimum of 19mm thick x 41mm wide. They shall be installed in a horizontal position, perpendicular to the airflow, supported by heavy-gauge HMG steel panels. Fill shall be capable of withstanding a hot water temperature of 54°C.

■ Splash fill has the longest history of successful use in the cooling tower industry. Its wide spacing discourages clogging, and its stout construction will withstand repeated cleaning of deposits associated with the circulating water quality.

7.2 Drift eliminators, installed inboard of the fill, shall be cellular type, triple-pass, manufactured of PVC. They shall be removable and replaceable, and shall limit drift to 0.010% of the circulating water flow. The final pass of the eliminators shall direct airflow toward the fan.

Fill options are available for hot water temperatures up to 66°C.



Drift rate varies with design water loading and air rate, as well as drift eliminator depth and number of directional changes. A drift rate of 0.001% is readily available on many standard models. If a lower rate is required, please discuss with your Marley sales representative.

7.3 The air intake faces of the tower shall be louvered full length, full height. Louvers shall be corrugated FRP. They shall be slip-fit into slotted sheet metal louver columns. Louvers shall be sloped to shed water inward to the tower, and shall be "sight-tight" at horizontal view.

Keep in mind...

- Drift for towers with three-pass high efficiency eliminators constitute a small percentage of water usage.
- Unlike thermal performance, drift rates are not certified and field drift tests are cost prohibitive for most applications.
- Drift rates below 0.001 are difficult to measure in the field.
- Certain water treatment chemicals can impact the drift rate.

Specifications

Specification Value

8.0 Hot Water Distribution System:

8.1 Two open basins (one above each bank of fill) shall receive hot water piped to each cell of the tower. These basins shall be installed and sealed at the factory, and shall be equipped with removable, galvanized steel covers capable of withstanding the loads described in paragraph 4.1. The water distribution system shall be accessible and maintainable during tower fan and water operation.

8.2 Each basin shall include an inlet hole and bolt circle to accept a 125# flange connection per ANSI B16.1. Removable, interchangeable long-stem polypropylene nozzles installed in the floor of these basins shall provide full coverage of the fill by gravity flow.

8.3 The water distribution system shall be accessible and maintainable while tower is operating.

9.0 Casing, Fan Deck and Fan Guard:

9.1 The casing and fan deck shall be heavy-gauge galvanized steel, and shall be capable of withstanding the loads described in paragraph 4.1. The top of the fan cylinder shall be equipped with a conical, non-sagging, removable fan guard, fabricated of welded 8mm and 7 gauge rods, and hot dip galvanized after fabrication. Fan cylinders 1.5m in height and over shall not be required to have a fan guard.

■ Gravity-flow distribution basins are a feature of crossflow type towers, resulting in operating pump heads of 3 to 6 meters less than that encountered in counterflow towers with pressurized spray systems. Also, these basins are located where they can be easily inspected—even maintained—while the tower is in operation.

Some manufacturers require shutting down the tower to clean the distribution system. Can you afford to do that?

■ Materials other than heavy-gauge steel for fan decks may be unable to meet your specified loading requirements. See remarks Guardrail and Ladder on page 32.

In addition steel is excellent at resisting damage, cracking, UV and fire.



Specifications

Specification Value

10.0 Access:

10.1 A large galvanized, rectangular access door shall be located on both end panels for entry into the cold water basin. Doors shall provide access to the fan plenum area to facilitate inspection and allow maintenance to the fan drive system.

11.0 Cold Water Collection Basin:

11.1 The collection basin shall be heavy-gauge galvanized steel and shall include the number and type of suction connections required to accommodate the out-flow piping system shown on the plans. Suction connections shall be equipped with debris screens. A factory installed, float operated, mechanical make-up valve shall be included. An overflow and drain connection shall be provided in each cell of the cooling tower. The basin floor shall slope toward the drain to allow complete flush out of debris and silt which may accumulate. Towers of more than one cell shall include steel flumes for flow and equalization between cells. The basin shall be accessible and maintainable while water is circulating.

- The access doors 76cm wide by 122cm high. Small access doors are prohibitive and discourage maintenance, which in turn can impact your operation. Specifying the size of the door will cause some bidders to take exception, alerting you to a potential maintenance headache. Two doors are standard on all NC towers—one in each endwall.



- The NC Alpha tower design offers side-suctions, side-outlet sumps, and bottom outlets to accommodate a significant variety of piping schemes. Unless so specified, the tower you may be asked to approve may only be available with one type of suction connection, requiring you to redesign your piping layout.

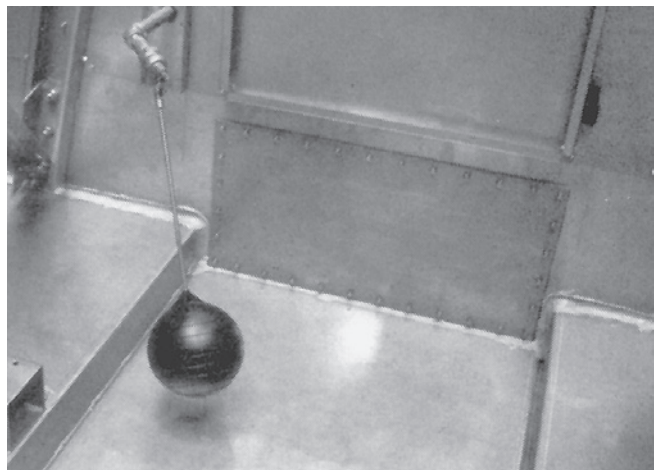

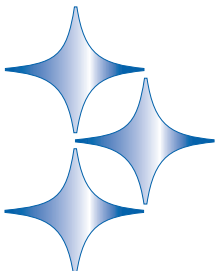
Specifications	Specification Value
<p>Stainless Steel Options</p>	
<p>Stainless Steel Collection Basin:</p>	
<p><u>11.1:</u> <i>Replace paragraph 11.1 with the following:</i> The collection basin shall be heavy-gauge S300 stainless steel, and shall include the number and type of suction connections required to accommodate the outflow piping system shown on the plans. Suction connections shall be equipped with stainless steel debris screens. A factory-installed, float-operated, mechanical make-up valve shall be included. An overflow and drain connection shall be provided in each cell of the cooling tower. The basin floor shall slope toward the drain to allow complete flush out of debris and silt which may accumulate. Towers of more than one cell shall include stainless steel flumes for flow and equalization between cells. The basin shall be accessible and maintainable while water is circulating. All steel items which project into the basin (columns, diagonals, anchor clips, etc.) shall also be made of stainless steel.</p>	<p>■ The collection basin is the only part of the tower that is subject to periods of stagnant water, concentrated with treatment chemicals and customary contaminants. It is also the most expensive and difficult part of any tower to repair or replace. For these reasons, many customers—particularly those who are replacing older towers—choose to specify stainless steel cold water basins.</p> <p>Also, see the notes on page 30 regarding the standard Cold Water Collection Basin. They apply equally well to the stainless steel basin.</p> 
<p>Stainless Steel Distribution Basin:</p>	
<p><u>8.1:</u> <i>Replace paragraph 8.1 with the following:</i> Two S300 stainless steel open basins (one above each bank of fill) shall receive hot water piped to each cell of the tower. These basins shall be installed and sealed at the factory, and shall be equipped with removable, stainless steel covers capable of withstanding the loads described in paragraph 4.1. All components of these basins, with the exception of the nozzles, shall be stainless steel.</p>	<p>■ The 316 alloy was designed to increase resistance to chlorides. Generally, cooling towers in HVAC service utilize water sources, which do not approach the limits of 300 series stainless, even up to several cycles of concentration. Industrial cooling towers, generally circulating more aggressive water, use 300 series stainless as standard metallurgy, upgrading to 316 for situations such as estuary water or other significant source of chlorides. The vast majority of cooling tower water sources result in an acceptable environment for 300 series stainless steel, with HVAC systems typically being on the mild end of the spectrum. If you have one of the rare instances where water quality exceeds 900 mg/L Cl then talk to you Marley sales representative about 316SS.</p>
<p>All Stainless Tower:</p>	
<p><u>5.1:</u> <i>Replace paragraph 6.1 with the following:</i> Except where otherwise specified, all components of the cooling tower shall be fabricated of heavy-gauge, series 300 stainless steel. The tower shall be capable of withstanding water having a chloride content (NaCl) up to 750 mg/L; a sulfate content (SO4) up to 1200 mg/L; a calcium content (CaCO3) up to 800 mg/L; silica (SiO2) up to 150 mg/L; and design hot water temperatures up to 52°C.</p>	<p>■ The corrosion potential of contaminated water increases with temperature—and these basins see the hottest water in the tower. If your design hot water temperature is over 52°C, or if your operating system can produce excursions beyond that point, you would be well advised to consider this option.</p> <p>■ For pure resistance to corrosion—coupled with the capability to meet stringent fire and building codes—there is no substitute for stainless steel. No paints or electrostatically-applied coating, however exotic they may be, can match stainless steel's ability to withstand adverse operating conditions.</p>

Specifications	Specification Value
<p>Convenience and Safety Options</p>	
<p>Guardrail and Ladder:</p>	
<p>10.2 <i>Add the following paragraph in the Access section:</i> The top of the tower shall be equipped with a sturdy guardrail, complete with kneerail and toeboard, designed according to OSHA guidelines and factory welded into subassemblies for ease of field installation. Posts, top rails and kneerails shall be 38mm square tubing. The guardrail assembly shall be hot dipped galvanized after welding and capable of withstanding a 890N concentrated live load in any direction. Posts shall be spaced on centers of 2.4m or less. A 46cm wide aluminum ladder with 76mm I-beam side rails and 32mm diameter rungs shall be permanently attached to the endwall casing of the tower, rising from the base of the tower to the top of the guardrail.</p>	<p>■ The NC Alpha cooling tower has been designed to minimize the need for maintenance personnel to get on top of the tower to perform maintenance and inspections.</p>
<p>10.2 <i>Add the following to the end of the above paragraph:</i> Provide a ladder extension for connection to the foot of the ladder attached to the tower casing. This extension shall be long enough to rise from the roof (grade) level to the base of the tower. The installing contractor shall be responsible for cutting the ladder to length; attaching it to the foot of the tower ladder; and anchoring it at its base.</p>	<p>For the comfort and safety of your operating personnel, we recommend that you specify a ladder and guardrail—and that you require it of all bidders! Although not required for safe operation by OSHA many user's own safety rules may dictate these options.</p>
<p>Ladder Extension:</p>	
<p>10.2 <i>Add the following to the end of the above paragraph:</i> Provide a ladder extension for connection to the foot of the ladder attached to the tower casing. This extension shall be long enough to rise from the roof (grade) level to the base of the tower. The installing contractor shall be responsible for cutting the ladder to length; attaching it to the foot of the tower ladder; and anchoring it at its base.</p>	<p>■ Many towers are installed such that the base of the tower is 61 cm or more above the roof or grade level. This makes it difficult to get up to the foot of the attached ladder. The ladder extension alleviates this problem. Marley ladder extensions are available in standard 1.5m and 3.3m lengths.</p>
<p>Ladder Safety Cage:</p>	
<p>10.3 <i>Add the following paragraph in the Access section:</i> A heavy gauge aluminum safety cage shall surround the ladder, extending from a point approximately 2m above the foot of the ladder to the top of the guardrail.</p>	<p>■ To meet OSHA guidelines, towers whose fan decks are 6m or more above roof or grade, and which are equipped with ladders, should have safety cages surrounding the ladders, but with approximately 2m clear headroom.</p>
<p>Ladder Safety Gate:</p>	
<p>10.3 <i>Add the following paragraph in the Access section:</i> A galvanized steel, self-closing gate shall be provided at the guardrail level of the ladder.</p>	<p>■ A galvanized self-closing gate located at the guardrail level of the fan deck, exterior motor access platform and access door platform. Stainless steel is available with the stainless guardrail option.</p>



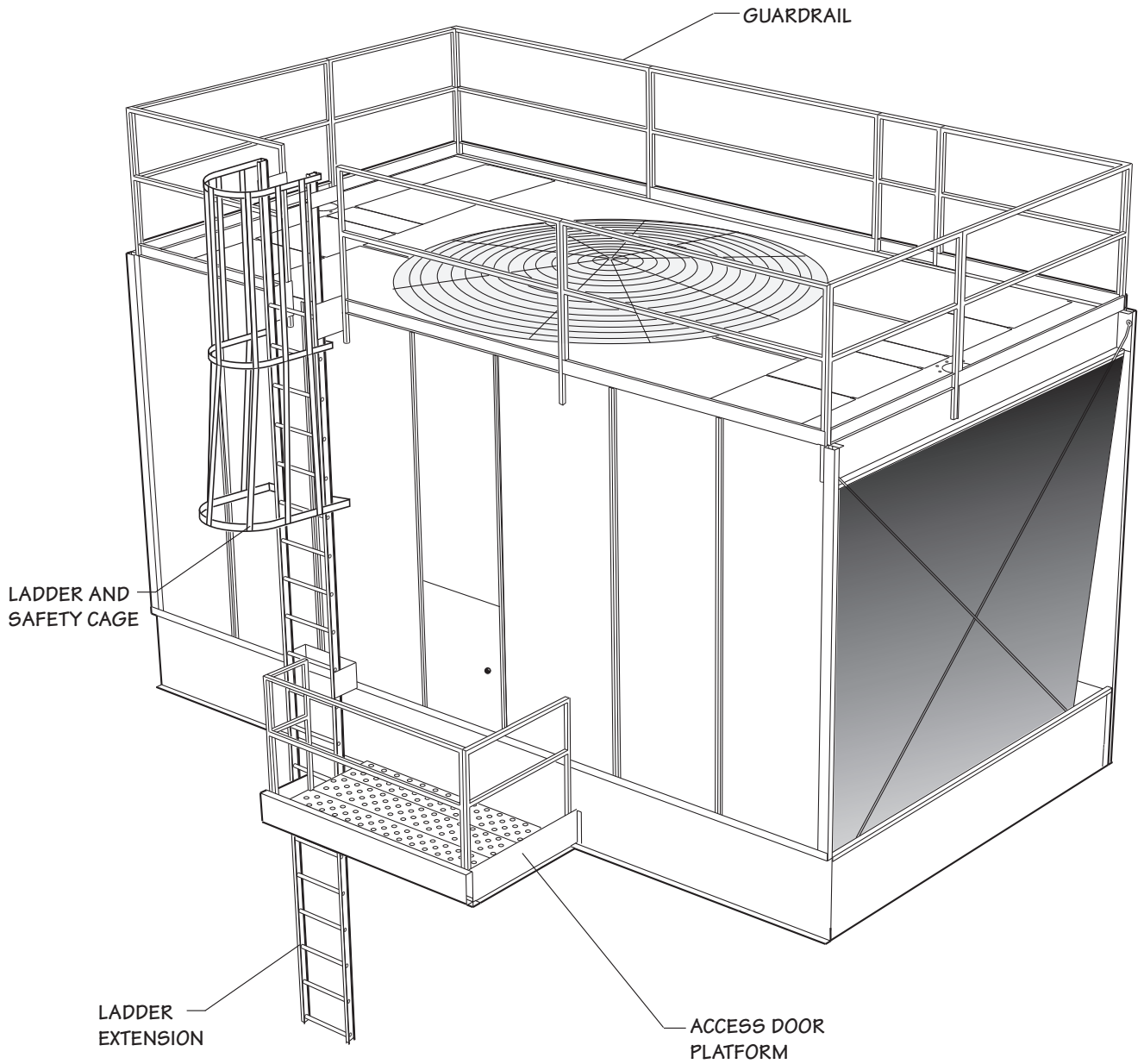

NOTE: NC FILM FILL TOWER SHOWN

Specifications

Access Door Platform:

10.2 *Add the following paragraph in the Access section:* There shall be an access platform at the base of the tower extending from the vertical ladder to the endwall access door. The platform shall be surrounded by a guardrail, kneerail, and toeboard.

Plenum Walkway:

10.2 *Add the following paragraph in the Access section:* Provide a factory-installed, walkway extending from one endwall access door to the other endwall. This walkway shall be supported by a steel framework, and the top of the walkway shall be at or above the cold water basin overflow level. Walkway and framework to be equivalent material to tower basin.

Interior Mechanical Equipment

Access Platform: NC8411 and NC8412

10.2 *Add the following paragraph in the Access section:* A factory-installed, elevated platform convenient to the care and maintenance of the tower's mechanical equipment shall be provided. Walkway and framework to be equivalent material to tower basin.

Interior Mechanical Equipment

Access Platform: NC8411 and NC8412

10.2 *Add the following paragraph in the Access section:* An internal ladder shall extend upward from the plenum walkway to an elevated fiberglass bar grating platform convenient to the care and maintenance of the tower's mechanical equipment. The platform shall be surrounded by a sturdy guardrail and kneerail system.

Specification Value

■ Where towers are installed on an elevated grillage or piers, it is often difficult to get to—and through—the access door conveniently. This platform provides easy, safe and comfortable access to that door. It also extends beyond the door to provide ready access to the optional Control System. See drawing on page 33

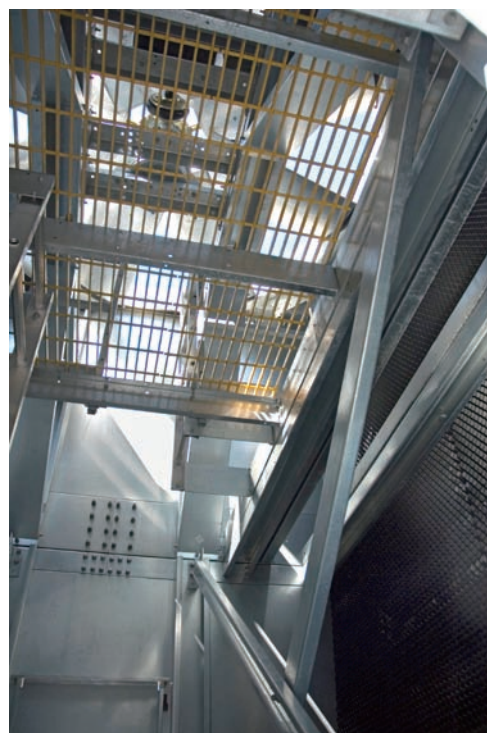

NOTE

OSHA and other concerned authorities are in the process of developing guidelines regarding the safety procedures and protective equipment that should be provided maintenance personnel who are required to go inside cooling towers. We feel it advisable to provide for as much maintenance as possible from outside the cooling tower and, to that end, offer such options as Guardrail and Ladder—pg 13, Ladder Extension—pg 13, Ladder Safety Cage—pg 13, Access Door Platform—pg 14, and Motor Out of the Airstream—pg 19. Such interior convenience options as Plenum Walkway—pg 14, that are offered are not meant as an invitation to perform inside maintenance. They are intended solely to maximize the comfort and safety of maintenance personnel during the performance of any inside work may become necessary.

Specifications

Specification Value

Control Options

Fan Motor Starter Control Panel:

6.4 *Add the following paragraph in the Mechanical Equipment section:* Each cell of the cooling tower shall be equipped with a UL listed control system in a IP14 or IP56 outdoor enclosure capable of controlling single-speed or two-speed motors as required, and designed specifically for cooling tower applications. The panel shall include a main fused disconnect or main circuit breaker with an external operating handle, lockable in the off position for safety. Across-the-line magnetic starters or solid-state soft-start starters as required shall be controlled with a thermostatic or solid-state temperature controller. Door mounted selector switches shall be provided to enable automatic or manual control and wired for 120VAC control. Control circuit to be wired out to terminal blocks for field connection to a remote vibration switch, overload trip alarms and remote temperature control devices. The temperature controller shall be adjustable for the required cold-water temperature. If a thermostatic controller is used it shall be mounted on the side of the tower with the temperature sensing bulb installed in the cold water basin using a suspension mounting bracket. If a solid-state temperature controller is used the controller will be door mounted on the control panel. The temperature controller will display two temperatures, one for outgoing water and the other for set point. Water temperature input shall be obtained using a three-wire RTD with dry well in the outlet water piping and wired back to the solid-state temperature controller in the control panel.

Marley TF Terminal Box:

6.4 *Add the following paragraph in the Mechanical Equipment section:* An externally mounted and wired terminal box shall be provided for each cell providing a single access location to the internal wiring. Terminate wiring for fan motor and options such as vibration switch, oil level switch and water level probes to the terminal box. The terminal box shall be built to UL508 standards and all terminal

■ If it is your opinion that the control system for the cooling tower be part of the tower manufacturer's responsibility, we are in wholehearted agreement with you. Who better to determine the most efficient mode and manner of a cooling tower's operation—and to apply a system most compatible with it—than the designer and manufacturer of the cooling tower?

Marley variable speed drives are also available for the ultimate in temperature control, energy management and mechanical equipment longevity. See specifications on page 37.



■ The Marley TF Terminal Box simplifies all electrical connections to the cooling tower motor and optional control accessories.

- Eliminates motor wiring errors in the field
- Reduces field wiring labor and materials
- Provides an external single access point to cooling tower wiring
- IP56 fiberglass enclosure suitable for corrosive applications
- Terminal points are well identified
- UL 508 assembly
- Optional disconnect for motor wiring and terminal box for control wiring

Specifications

points marked for ease of connection in the field. The enclosure shall be IP56 fiberglass. Entry points shall be into and out of the bottom of the enclosure preventing water collection in the enclosure.

Vibration Limit Switch:

6.5 *Add the following paragraph in the Mechanical Equipment section:* A single-pole, double-throw vibration limit switch in a IP56 housing shall be installed on the mechanical equipment support for wiring into the owner's control panel. The purpose of this switch will be to interrupt power to the motor in the event of excessive vibration. It shall be adjustable for sensitivity, and shall require manual reset.

Basin Heater:

11.2 *Add the following paragraph in the Cold Water Basin section:* Provide a system of electric immersion heaters and controls for each cell of the tower to prevent freezing of water in the collection basin during periods of shutdown. The system shall consist of one or more stainless steel electric immersion heaters installed in threaded couplings provided in the side of the basin. A IP56 enclosure shall house a magnetic contactor to energize heaters; a transformer to provide 24-volt control circuit power; and a solid-state circuit board for temperature and low water cut-off. A control probe shall be located in the basin to monitor water level and temperature. The system shall be capable of maintaining 4°C water temperature at an ambient air temperature of _____ °C.

Electric Water Level Control:

11.1 *Replace this paragraph with the following:* The collection basin shall be heavy-gauge galvanized steel and shall include the number and type of suction connections required to accommodate the out-flow piping system shown on the plans. Suction connections shall be equipped with debris screens. A solid-state water level control system to monitor the water level with a multi-relay control panel pre-wired and mounted in a IP56 nonmetallic enclosure shall be provided. The system shall consist of water level sensing and control units in quantities and locations

Specification Value

■ Unless specified otherwise, a Marley M-5 vibration switch will be provided. The requirement for manual reset assures that the cooling tower will be visited to determine the cause of excessive vibration.



■ The Marley basin heater components described at left represent our recommendation for a reliable automatic system for the prevention of basin freezing. They are normally shipped separately for installation at the jobsite by the installing contractor. When purchased in conjunction with the enhanced Control System option, however, they are customarily factory-mounted and tested.

Submerged in basin water, in which zinc ions are present, copper immersion heaters must not be used. Insist upon stainless steel.

The ambient air temperature that you insert in the specifications should be the lowest 1% level of winter temperature prevalent at site.



■ Solid-state liquid level controls provide you with state of the art systems to control and monitor the water level in your cooling tower collection basin. Relays operating in conjunction with suspended stainless steel electrode probes monitor basin water levels, providing simple solenoid-valve water makeup or discrete on/off signals to more sophisticated automation controls. Optional configurations might include makeup along with high and low water level alarm and cutoff, or pump cutoff. Packaged systems including any of these variations are available. Consult you Marley sales representative or download a copy of ACC-NC-9D from spxcooling.com for additional information.

Specifications	Specification Value
<p>as indicated on the drawings. An overflow and drain connection shall be provided in each cell of the cooling tower. The basin floor shall slope toward the drain to allow complete flush out of debris and silt which may accumulate. Towers of more than one cell shall include steel flumes for flow and equalization between cells. The basin shall be accessible and maintainable while water is circulating.</p> <p>Fan Motor Variable Speed Drive:</p> <p>Marley All Weather ACH550 System</p> <p>6.4 <i>Add the following paragraph in the Mechanical Equipment section when VFD is used with customers Building Management System:</i> A complete UL listed Variable Speed Drive system in a IP10 indoor, IP52 indoor or IP14 outdoor enclosure shall be provided. The VFD shall use PWM technology with IGBT switching and integrated bypass design. VFD out put switching shall not cause mechanical issues with gearbox teeth or drive shafts. The VFD shall catch a fan spinning in the reverse direction without tripping. The panel shall include a main disconnect with short circuit protection and external operating handle, lockable in the off position for safety. The VFD system shall receive a speed reference signal from the Building Management System monitoring the tower cold-water temperature. As an option to receiving the speed reference signal from a building management system, the drive must have the capability to receive a 4-20 ma temperature signal from an RTD transmitter. The VFD shall have an internal PI regulator to modulate fan speed maintaining set point temperature. The drive's panel display shall be able to display the set-point temperature and cold-water temperature on two separate lines. The bypass shall include a complete magnetic bypass circuit and with capability to isolate the VFD when in the bypass mode. Transfer to the bypass mode shall be manual in the event of VFD failure. Once the motor is transferred to the by-pass circuit the fan motor will run at constant full speed. The bypass circuit will not modulate ON and OFF based on cold-water temperature. The application must be able to handle very cold water while VFD is in a by-pass</p>	<ul style="list-style-type: none"> ■ Marley Variable Speed Drive systems are designed to combine absolute temperature control with ideal energy management. The cooling tower user selects a cold water temperature and the drive system will vary the fan speed to maintain that temperature. Precise temperature control is accomplished with far less stress to the mechanical equipment components. The improved energy management provides fast payback to the user.

Specifications	Specification Value
----------------	---------------------

mode. Operator controls shall be mounted on the front of the enclosure and shall consist of start and stop control, bypass/VFD selection, Auto/Manual selections, manual speed control. To prevent heating problems in the cooling tower fan motor the VFD system shall de energize the motor once 25% motor speed is reached and cooling is no longer required. The cooling tower manufacturer shall supply VFD start-up assistance. Tower vibration testing throughout the speed range is required to identify and lockout any natural frequency vibration levels which may exceed CTI guidelines.

Marley Premium VFD System:

6.4 *Add the following paragraph in the Mechanical Equipment section when VFD is used as a stand alone system: A complete UL listed Variable Speed Drive system in a IP52 indoor or IP14 outdoor enclosure shall be provided. The VFD shall use PWM technology with IGBT switching and integrated bypass design. VFD output switching shall not cause mechanical issues with gearbox teeth or drive shafts. The VFD shall catch a fan spinning in the reverse direction without tripping. The panel shall include a main disconnect with short circuit protection and external operating handle, lockable in the off position for safety. The system shall include a solid state, PI temperature controller to adjust frequency output of the drive in response to the tower cold-water temperature. The temperature of the cold water and set point shall be displayed on the door of the control panel. The bypass shall include a complete magnetic bypass circuit with capability to isolate the VFD when in the bypass mode. Transfer to the bypass mode shall be automatic in the event of VFD failure or for specific trip conditions allowing safe transfer of utility voltage to the motor. Automatic bypass with an earth ground condition is not allowed. The bypass contactor shall be cycled on and off while operating in bypass, to maintain the set-point temperature of the cold water. The drive design shall be operated as a stand-alone system without the need for a BMS system. Operator controls shall be mounted on the front of the enclosure and shall consist of start and stop con-*



Specifications	Specification Value
<p>trol, bypass/VFD selector switch, Auto/Manual selector switch, manual speed control, and solid-state temperature controller. An emergency bypass selector switch internal to the panel allowing the cooling tower fan motor to be run at full speed shall be furnished. To prevent heating problems in the cooling tower fan motor the VFD system shall de energize the motor once 25% motor speed is reached and cooling is no longer required. The VFD shall include de-icing logic with auto canceling and adjustable time. Speed in De-Ice mode shall not exceed 50 % motor speed. The cooling tower manufacturer shall supply VFD start-up assistance. Tower vibration testing throughout the speed range is required to identify and lockout any natural frequency vibration levels which may exceed CTI guidelines.</p>	<ul style="list-style-type: none"> ■ For many years, a feature of Marley cooling towers was that the electric motors were located outside the fan cylinders, where they were easily accessible, and where they were not subjected to the constant humidity that exists inside the tower plenum.
<p>Miscellaneous Options</p>	
<p>Motor Outside of the Airstream:</p>	<p>Although improved motor designs (insulation, bearings, seals, and lubricants) have now made it feasible for us to locate the motor inside the tower in close-coupled proximity to the Geareducer® (page 28), many users still prefer the motor to be located outside the humid airstream. If you are among those users—or are among those who see the wisdom of their thinking—please specify this option. If you do, however, please require it of all bidders.</p>
<p><u>6.1</u> <i>Add the following to the end of this paragraph:</i> The motor shall be mounted outside the casing of the tower, and shall be connected to the gear reducer by a dynamically-balanced, stainless steel tube and flange driveshaft.</p>	<ul style="list-style-type: none"> ■ Extensions are available in 305mm increments to a maximum height equal to the diameter of the fan. Such extensions may be considered necessary in order to elevate the discharge beyond the bounds of an enclosure. Discuss applicability with your local Marley sales representative.
<p>Fan Cylinder Extensions:</p>	
<p><u>9.1</u> <i>Insert the following after the first sentence:</i> Fan cylinder extensions shall be provided to elevate the fan discharge to a height of ___ ft above the fan deck level.</p>	

Specifications

Inlet Flow Control Valves:

8.2: Add the following to the end of the paragraph: Heavy-duty flow-regulator valves shall be provided at the hot water inlet connections. These valves shall be disc-type, with cast iron bodies and stainless steel operating stems. There shall be a locking handle to maintain the valve setting in any position. Valves shall be right-angle configuration, precluding the need for inlet elbows.

Equalizer Flume Weir Gates:

11.2: Add the following paragraph under Cold Water Collection Basin: The interconnecting flume between cells shall be equipped with a removable cover plate to permit the shutdown of one cell for maintenance purposes, or to permit independent cell operation.

Sound Control:

1.2 Add the following paragraph under Base: The cooling tower shall be quiet operation, and shall produce an overall level of sound not higher than _____ dB(A) measured at _____ ft from the locations in the table below.

Location	63	125	250	500	1000
Discharge					
Air Inlet					
Cased Face					

Location	2000	4000	8000	Overall dB(A)
Discharge				
Air Inlet				
Cased Face				

Specification Value

■ Marley flow-control valves have been a favorite of users since the 1950s. They remain serviceable for the life of the tower and provide a continuing means of flow-regulation between hot water basins—and between cells of multicell towers as well.



■ Where it is your intention to be able to operate both cells of the tower while the flume cover plate is installed, separate outlet connections, float valves and overflows must be provided for each cell. Likewise, this would require separate sensors and controls for basin heater systems, if installed.

■ Sound produced by a standard NC Alpha cooling tower operating in an unobstructed environment will meet all but the most restrictive noise limitations—and will react favorably to natural attenuation. Where the cooling tower has been sized to operate within an enclosure, the enclosure itself will have a damping effect on sound. Sound also declines with distance—by about 5 or 6 dB(A) each time the distance doubles. Where noise at a critical point is likely to exceed an acceptable limit, you have several options—listed below in ascending order of cost impact:

- Where only a slight reduction in noise will satisfy—and the source of concern is in a particular direction—merely turning the cooling tower may be the answer. Less sound emanates from the cased face of the cooling tower than does from the air intake face.
- In many cases, noise concerns are limited to nighttime, when ambient noise levels are lower and neighbors are trying to sleep. You can usually resolve these situations by using two-speed motors—operating the fans at reduced speed without cycling “after hours”. The natural nighttime reduction in wet-bulb temperature makes this a very feasible solution in most areas of the world, but the need to avoid cycling may cause the cold water temperature to vary significantly.
- A Marley Variable Speed Drive automatically minimize the tower’s noise level during periods of reduced load and/or reduced ambient temperature without sacrificing the system’s ability to maintain a constant cold water temperature. This is a relatively inexpensive solution, and can pay for itself quickly in reduced energy costs.
- The most extreme cases may require discharge sound attenuator sections—however, the static pressure loss imposed by discharge attenuators may necessitate an increase in tower size. Two stages of discharge attenuators supported by the tower and designed and tested for the most stringent requirements are available as an option.

Specifications	Specification Value
<p>Outlet Sound Attenuation:</p> <p>1.4 <i>Add the following paragraph under Base:</i> The cooling tower shall be equipped with outlet sound attenuation baffles positioned and spaced horizontally across the entire fan opening. The baffles will be constructed of perforated sheet metal and contained within a steel box which is self supporting.</p>	
<p>Quiet Fan:</p> <p>6.1 <i>Replace paragraph 6.1 with the following:</i> Fan(s) shall be propeller-type, incorporating a minimum of seven wide-chord aluminum alloy blades and galvanized hubs. Blades shall be individually adjustable. Maximum fan tip speed shall be 56 m/s. Fan(s) shall be driven through a right angle, industrial duty, oil lubricated, geared speed reducer that requires no oil changes for the first five (5) years of operation. The gearbox bearings shall be rated at an L10A service life of 100,000 hours or greater.</p> <p>6.1 (alternate)* Fan(s) shall be propeller-type, incorporating a minimum of seven wide-chord aluminum alloy blades and galvanized hubs. Blades shall be individually adjustable. Fan(s) shall be driven through a one-piece multi-groove, solid back V-type belt, pulleys, and tapered roller bearings. Bearings shall be rated at an L10A service life of 40,000 hours or greater. *Currently available on all models 45kW or less.</p> <p>Single Hot Water Inlet Connection per Cell:</p> <p>8.2 <i>Replace this paragraph with the following:</i> Each cell of the tower shall include a single hot water inlet connection located as shown on the plans. An internal system of piping shall deliver water equally to the distribution basins without the need for balancing valves. This internal piping system shall require no scheduled maintenance, and shall be located such that it does not interfere with normal maintenance access. The internal piping must extend to the tower exterior. Removable, interchangeable polypropylene nozzles installed in the floor of these basins shall provide full coverage of the fill by gravity flow.</p>	<ul style="list-style-type: none"> ■ The Marley "Quiet Package" includes the affordable Quiet Fan mechanical option, optimized to achieve the lowest possible sound levels while maintaining efficiency. In combination with a Marley Variable Speed Drive, this package is capable of meeting all but the most restrictive noise limitations. ■ Tip Speed—unlike thermal performance, no certification program exists for sound. While Marley conducts actual sound tests on all its configurations there are only a few ways for the client to ensure they get a quiet tower. <ul style="list-style-type: none"> • One is to conduct a field sound test after installation. On-site testing after installation can however be inaccurate depending on the environment. • Another is to conduct a sound test at the factory. However both can be cost prohibitive for smaller applications. • Specifying fan blade tip speed is one way to physically force the tower selection to be quiet. Tip speed is easily checked by multiplying the fan rpm by the fan circumference at the blade tip (π fan dia). Over 61 m/s is considered high by most people. 51-61 is considered typical and expected. 41-51 would be considered low noise. Below 41 is difficult to hear above the water noise. ■ This option reduces what might otherwise be a complex hot water piping layout to a simple, single connection per cell. It also avoids an unsightly (perhaps unsafe) maze of pipe exposed above the top deck of the tower. <p style="margin-left: 20px;">The single inlet connection is located in the tower's endwall casing</p> <p style="margin-left: 20px;">Be sure to specify that the internal pipe extends to the tower exterior casing panel. Some manufacturers require the contractor to complete the internal piping adding to your cost.</p>

Specifications	Specification Value
<p>Multicell Basin Equalizer Outlets:</p> <p>11.1 <i>Add the following paragraph in the Access section:</i> A hole and bolt circle shall be provided in the depressed section of the basin for equalizer piping between cells. A full-face, .6mm thick, 50 durometer gasket shall be provided at each equalizer location.</p> <p>Extended Geareducer Lube Line with Dipstick:</p> <p>6.1 <i>Add the following paragraph in the Mechanical Equipment section:</i> An external oil level dipstick shall be located adjacent to the motor at the fan deck surface and shall be accessible from a portable maintenance ladder.</p> <p>Premium Efficiency Motor:</p> <p>6.3 <i>Replace paragraph 6.3 with the following:</i> The complete mechanical equipment assembly for each cell shall be supported by a rigid steel structural support that resists misalignment between the motor and the gear reducer. The mechanical equipment assembly shall be warranted against any failure caused by defects in materials and workmanship for no less than five (5) years following the date of tower shipment. This warranty shall cover the fan, speed reducer, motor, drive shaft and couplings, and the mechanical equipment support.</p>	<ul style="list-style-type: none"> ■ Used as water level equalizers between multicell towers. Not intended for water migration. Piping and attachment hardware by others. Flat faced flange required. ■ The dipstick option is accessible from a portable maintenance ladder on one and two cell towers only. Maintenance considerations recommends this option be combined with the ladder and guardrail option on installations of three or more cells since the dipstick cannot be reached without accessing the fan deck. ■ IEC premium efficiency motor with a five year warranty enhances the standard five year mechanical equipment warranty of the NC Alpha cooling tower.



COOLING TECHNOLOGIES

UNIT 505, BLOCK B
PHILEO DAMANSARA 2
NO. 15 JALAN 16/11
OFF JALAN DAMANSARA
46350 PETALING JAYA, MALAYSIA
60 3 7947 7800
spxcooling.asiapacinfo@spx.com
spxcooling.com

In the interest of technological progress,
all products are subject to design and/or
material change without notice.
©2010 SPX Cooling Technologies
sea_NCA-TS-10B