

Marley® NC Fiberglass Cooling Tower



**Introducing the latest
generation NC® Fiberglass
Cooling Tower**

Marley Is Raising The Industry Bar – Again.



Sacrifice nothing

If you're looking for maximum value in a package cooling tower, look no further than the latest NC Fiberglass from Marley. After all, why sacrifice productivity for value when you can have both with the Marley NC cooling tower?



Highest efficiency

All that capacity is achieved with even less power – lowering operation costs and energy usage – with more models meeting ASHRAE90.1 and China efficiencies than any other manufacturer.

Smaller profile

Increasing capacity and efficiency typically means increasing size. Not with the new Marley NC Fiberglass. Many models are the same or smaller footprint than before. In addition, there is a 100 to 400mm height reduction from previous comparable models, saving costs for architectural walls and enclosures.



With higher capacity and efficiency per cell within a smaller footprint, this NC will reduce costs for an even wider array of applications.

More applications

The NC has the right combination of increased efficiency and reduced footprint to bring the performance of a crossflow cooling tower to more applications than ever before.

Marley reliability

As a recognized leader in product quality, the greatest value of all might just be the name on the side. Our reputation, our service and our 87-year history of excellence deliver the peace of mind that comes from knowing you've made a quality choice. Now, more than ever, value is important when looking for the best cooling solution. The latest generation NC Fiberglass from Marley delivers more value than ever before.

Is the Marley NC Right for Your Application?

The best way to see if a Marley NC Fiberglass suits your needs is to have us run a complimentary product match analysis of your specific installation or plans. You can do it yourself or contact your local Marley sales representative.

[Find out at spxcooling.com/update](https://www.spxcooling.com/update)

Enter the key specs you're working with, and make your own selection.

The NC is redefining crossflow cooling towers.





The perfect fit makes all the difference.

See how the best gets even better. There's a Marley NC that's ideal for your application.

Industry-leading features and options of the Marley NC.

- Drift rates as low as .001% of design flow rate are available on many standard models – the lowest drift rates of any standard crossflow configuration.
- Marley horizontal control inlet valves. Provides a continuing means of flow-regulation between hot water basins – and between cells of multicell towers as well.
- Optional gear drive – the Marley Geareducer® is now available on all models.
- Largest selection of options and accessories. Select and customize your NC with a large selection of optional features.
- The most CTI-certified low-sound options, with low-sound fans standard on all NC models.

TOWER MODELS	CAPACITY kW	L	W	H
NC8401	444–870	1988	3912	3105
NC8402	576–1218	2559	4318	3124
NC8403	936–1860	2559	5537	3638
NC8405	1455–2264	3016	6071	3639
NC8407	1486–3033	3626	6401	3651
NC8409	2145–3438	4235	6833	3651
NC8411*	2796–4480	3626	6833	5742
NC8412*	3126–5447	4235	6833	5742
NC8413*	3042–5337	3326	6833	6888
NC8414*	3389–6326	4235	6833	6888

*Two-story modular cells

**Velocity recovery fan cylinders required on some models in this box size

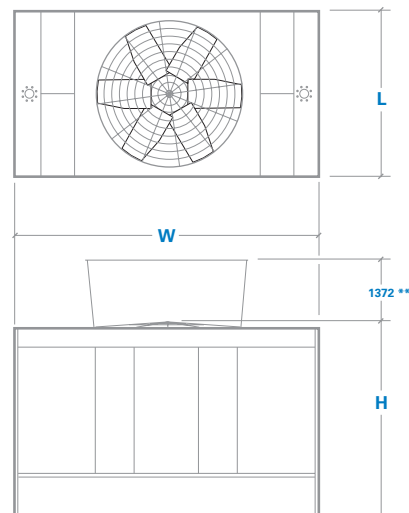

The Marley NC sets the standard on certifications and standards.



The NC has codes and certifications covered.

CTI, ASHRAE, ASCE, OSHA, ACOP L8, China GB7, Eurovent, ISO, BSI, etc. – the NC is covered with the codes you need now and for the future. Plus, we have more models meeting the China efficiency standards than ever before. And all models are ASHRAE 90.1 compliant.

See increased value from the very beginning.

- Affordable performance – delivered when you need it, wherever you need it.
- Ease of installation. 87 years in the business have taught us to streamline the installation process and to anticipate the installation needs for numerous applications.



**COOL IS
GREEN
IS COOL™**

The NC is greener, too.

Greater energy efficiency is just the beginning of the green story. The NC employs water-saving strategies to help achieve sustainable building goals. Being green can do more than help with projects – it can boost your bottom line.

Simply put, the latest generation NC Fiberglass from Marley is a crossflow cooling tower like no other.



ADDITIONAL NC COOLING TOWER PUBLICATIONS

For further information about the NC Cooling Tower – including engineering schematics, data, layout requirements and more – ask your Marley sales representative for a copy or download at spxcooling.com:



NC Fiberglass
Engineering Data
and Specifications



NC Steel
Engineering Data



NC Steel
Specifications

OTHER SPX COOLING TECHNOLOGIES PRODUCTS

SPX Cooling Technologies offers a full line of industry leading products – with exceptional support and innovation designed to help you get the most out of your cooling process. Take a look at these other SPX Cooling Technologies products:



Marley MD Class
Cooling Tower



Marley Aquatower®
Cooling Tower



Marley AV Series
Cooling Tower

SPX Cooling Technologies is a world-leading full-line cooling tower and air-cooled condenser manufacturer. The company provides exceptional-quality evaporative cooling towers, fluid coolers and evaporative condensers under the Marley, Recold and Balcke brand names.

SPX[®]

COOLING TECHNOLOGIES

3 KNIGHTSBRIDGE PARK
WAINWRIGHT ROAD
WORCESTER WR4 9FA
UNITED KINGDOM
44 (0) 1905 750 270
info.uk@spx.com
spxcooling.com

In the interest of technological progress, all products are subject to design and/or material change without notice.
©2010 SPX Cooling Technologies
uk_NCF-10