

WaterGard™ model WG002-WG004-WG007-WG009

INSTALLATION - OPERATION - MAINTENANCE

10000022002_A ISSUED 9/2024

READ AND UNDERSTAND THIS MANUAL PRIOR TO OPERATING OR SERVICING THIS PRODUCT.

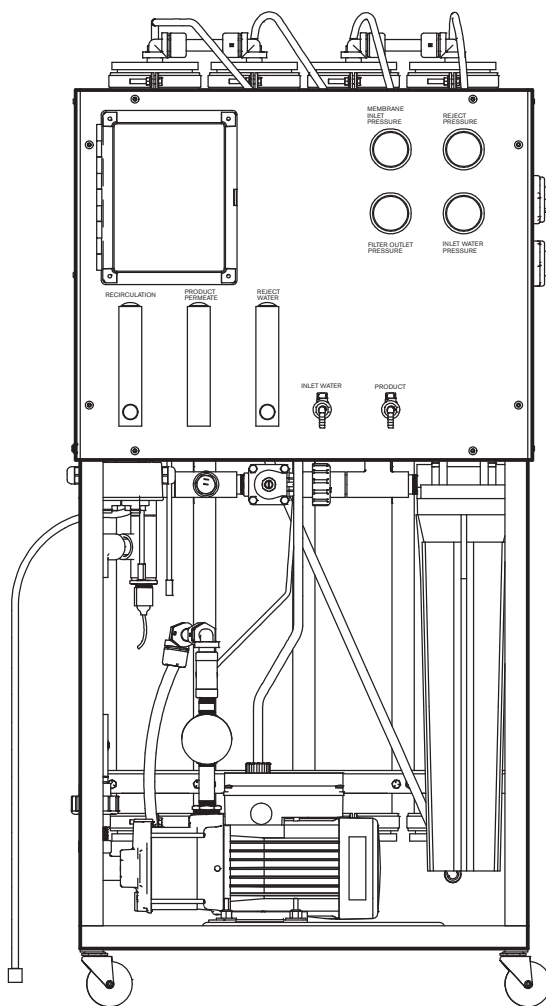

contents

Note

This manual contains vital information for the proper installation and operation of the Marley WaterGard system. Carefully read the manual before installation or operation and follow all instructions. Save this manual for future reference.

Technical Information.....	4
System Requirements.....	5
Schematics and Components	6
Rigging	8
Physical System Requirements	8
Electrical Requirements.....	9
Piping Connections.....	9
Startup and Operation.....	10
System Shutdown.....	12
Automatic System Standby and Restart	12
WaterGard Controls.....	13
Operating Status Messages	14
Fault Condition Display.....	16
Controller Adjustment.....	18
Conductivity Calibration	19
Standard Setpoints	21
Troubleshooting.....	22
Maintenance.....	24
Parts List	28
System Log	29

overview

This User Manual as well as those offered separately on other components, etc., are intended to assure that the WaterGard system serves you properly for the maximum possible time. Since product warrantability may well depend upon your actions, please read this User Manual thoroughly prior to operation.

This User Manual provides information regarding general installation and operation. Any deviation from, change or modification to, the User Manual, the original design conditions or the original intended use of the equipment may result in improper installation and/or operation.

Any such deviation, change or modification shall be the responsibility of the party or parties making such deviation, change or modification. SPX Cooling Tech expressly disclaims all liability for any such deviation, change or modification. The equipment shall be warranted in accordance with the applicable SPX Cooling Tech Certification of Limited Warranty.

The following defined terms are used throughout this manual to bring attention to the presence of hazards of various risk levels, or to important information concerning the life of the product.

⚠ Warning

Indicates presence of a hazard which can cause severe personal injury, death or substantial property damage if ignored.

⚠ Caution

Indicates presence of a hazard which will or can cause personal injury or property damage if ignored.

Note

Indicates special instructions on installation, operation or maintenance which are important but not related to personal injury hazards.

overview

Technical Data

Table 1

Specifications				
Model	WG002	WG004	WG007	WG009
Performance				
Nominal Rejection	91%			
Rated Product Flow – gpm*	2.2	4.4	7.3	9.0
Recovery	85-90%			
Membranes				
Size	4" x 40"	4" x 40"	4" x 40"	4" x 40"
Quantity	2	4	6	18
Type	Low fouling spiral-wound composite			
Inlet Pressure Range - psig	30-80			

* Product flow rate varies with temperature. All models are rated at 60°F (15.5°C).
Permeate flow for individual elements may vary -20 +25%.

Table 2

Maximum and Minimum Flow					
Model	Flow - gpm			Reject Minimum gpm	Reject Maximum gpm
	Minimum 50°F	Minimum 60°F	Maximum 50°F		
WG002	2	2.2	2.75	.22	.61
WG004	4	4.4	5	.44	1.21
WG007	6	7.3	8	.73	2.01
WG009	8	9.0	10.5	.9	2.48

Table 3

Feedwater Requirements	
Maximum Chlorine Concentration	< 0.1 ppm
Maximum Operating Temperature	113° F
Maximum Feedwater Turbidity	1.0 NTU
Maximum Feedwater SDI	5.0
Oil and Grease	Max 0.1 mg/L
Operating pH Range	2-10
Cleaning pH Range	1-12
Sediment Filtration	5 microns

overview

System Requirements

For WaterGard to function correctly these items are required:

- Two dry contacts from a generic water level controller. One signal for turning the unit on (Makeup On) and one for switching the unit into bypass operation (Low Level Alarm). SPX Cooling offers multiple WaterGard Ready options for liquid level control including the Marley LLC (liquid level control) probe style) and the Marley LLC+u (ultrasonic) water level control system.
- Municipal potable water is required, however other sources are possible please consult SPX for more information.
- Municipal potable water will have residual chlorine levels that are too high for WaterGard, therefore, a method of removal is required when any water source has a free residual chlorine level above the requirements shown in the Feedwater Requirements **Table 3**. This can either be done by purchasing a carbon tank through SPX Cooling or using liquid chemical chlorine destruct from a chemical water treater.
- A conductivity blowdown controller is required to monitor the water saving WaterGard offers. This can be purchased with the WaterGard system.

WaterGard can remove up to 91% of an individual ion. How much of an individual ion is removed depends on the ion. In some cases, the incoming water in a galvanized evaporative product may have too low of a calcium value (<50 ppm as CaCO₃) or pH may be too low (<6.5) making the water corrosive after WaterGard treatment. In these situations, it is recommended to initially fill the system with unfiltered feed water. If the system level is low enough, the internal bypass will automatically fill with unfiltered water. Otherwise, if the system level isn't low enough the external bypass will need to be engaged by jumping the low-level alarm. For LLC applications, once the system level is above the low-level alarm a delay timer will continue to fill the unit for 20 seconds, then WaterGard will start and operated normally. For Opti FC/LLC+u controls application, once the water level is above low-level alarm, the unit will keep bypass open until water level reaches the "makeup ON" setpoint. For additional information on soft water and its impact on tower metallurgy consult you Marley sales representative.

WaterGard operates by rejecting ions down a small, concentrated waste stream. This is typically 10-15% of the feedwater stream. Due to this, water savings are not possible when the evaporative system operates at higher cycles of concentration (COC). Any evaporative system's starting COC at 7 or higher can result in increased water usage, not water savings.

overview

Schematics and Components

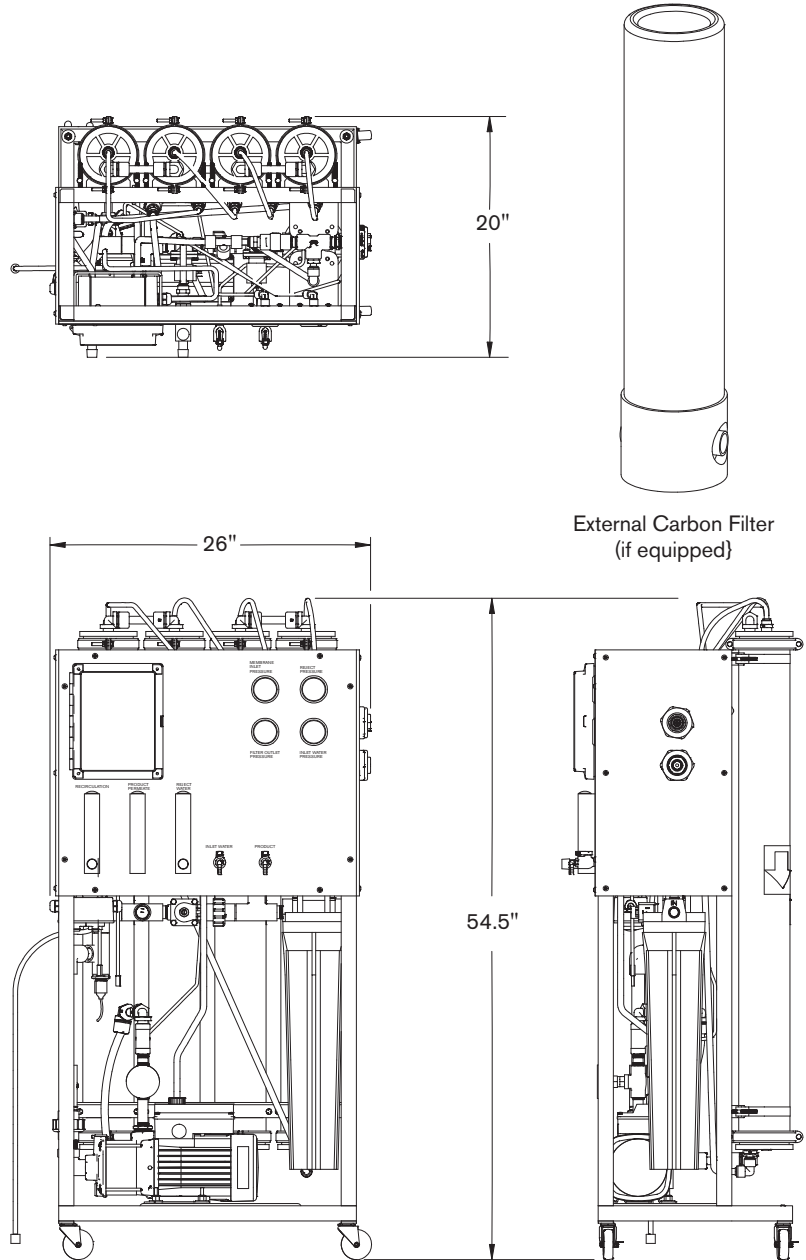

Figure 1

WG002 and WG004 Component Dimensions (WG004 shown)

overview

Schematics and Components

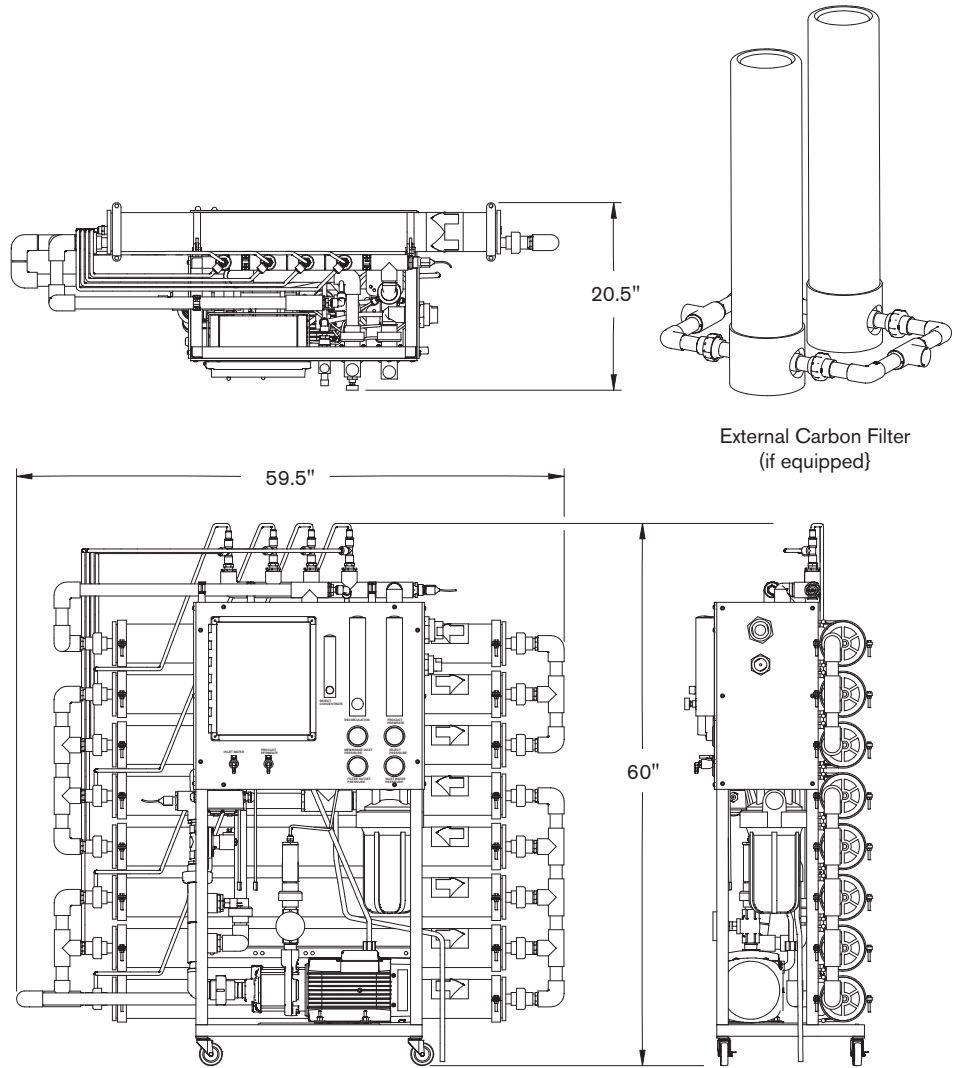

Figure 2

WG007 and WG009 Component Dimensions (WG009 shown)

installation

Rigging

The WaterGard unit should be lifted and moved by a forklift. If the WaterGard unit is lifted by a crane it should be lifted from the bottom using a platform. The unit should be secure to the platform using the anchor locations. A test lift should be done in order to determine the weight centerline.

Do not allow rigging straps to contact system components.

Caution

Physical System Requirements

- WaterGard is for indoor use **only**. If the end user desires the unit to be placed outdoors it is the sole responsibility of the end user to protect the unit from freezing and inclement weather conditions.
- Ideally WaterGard should be located out of direct sunlight. If this is not possible some components may experience discoloration from direct UV rays due to sunlight. This is mainly an aesthetic issue and won't adversely impact performance.
- WaterGard should be located on a level floor or housekeeping pad.
- Floor load rating must be sufficient to accept WaterGard weight.
- The location must be dry and frost-free.
- Normally, inlet water temperature should not exceed 77°F. Water temperatures from 77°F to 113°F will negatively impact the quality of the water. Anything above 113°F may impact the integrity of the membrane.
- Feedwater to the WaterGard unit must not contain chlorine or oil. For more information refer to **Table 3**.
- A floor drain close to the unit is required that can carry away the reject flow from the WaterGard system. See **Table 2** for reject flow requirements.
- The water pressure at the WaterGard inlet when in operation, must be a minimum of 30 psi, and must not exceed a maximum of 80 psi. If the pressure exceeds the maximum stated pressure, or if it fluctuates to pressures exceeding 80 psi, install a pressure-reducing valve at the inlet.
- The flow of inlet water supplied to the WaterGard unit shall be an uninterrupted flow at 30 psi minimum, and at a minimum flow rate of twice the rated product water flow of the WaterGard unit purchased. See **Table 2** for minimum flow rates.
- WaterGard should be additionally secured in areas where necessary using seismic and wind rated anchor bolts and straps. All applicable local codes shall be followed.

installation

Electrical Requirements

⚠ Warning

WaterGard's provided cord serves as the ground. Conduit and water pipes are NOT an acceptable ground.

- All wiring must be properly sized, rated, and connected in accordance with local, state, and national electrical codes. The system is pre-wired and tested at the factory. See provided sales drawing for additional details.
- The WaterGard unit should be on a dedicated circuit originating at a service disconnect panel. Refer to unit nameplate for correct voltage information.
- The electrical voltage and phase must match and be verified to the WaterGard unit that was purchased.

⚠ Caution

Do not operate pump dry. Damage to pump seal and shaft may occur.

Piping Connections

- All piping, valves, etc. for the product permeate water outlet of the WaterGard unit must be made of PVC, PP, PEX, or corrosion resistant stainless steel. Local plumbing codes must be observed and followed.
- The carbon filter (if present) must be installed upstream from the WaterGard unit. This is designed to remove any residual chlorine present in the feedwater stream. For information on pipe sizes for each unit reference the installation and/or sales drawing
- In cases where it is not desired to fill the evaporative product's collection basin during startup, a section of piping can be added downstream of the WaterGard unit to send the product water to the drain, in order to startup WaterGard.

⚠ Caution

Properly secure all pipe runs. Pipe movement may cause damage to WaterGard and/or pipe. Ensure waste drain line is adequately sized and free flowing to handle the reject flow. Reject flow rates can be



operation

found in Table 2.

The drain for the WaterGard unit must be designed and constructed to provide for connection to the sanitary waste system through an air gap of two pipe diameters or 1" whichever is larger.

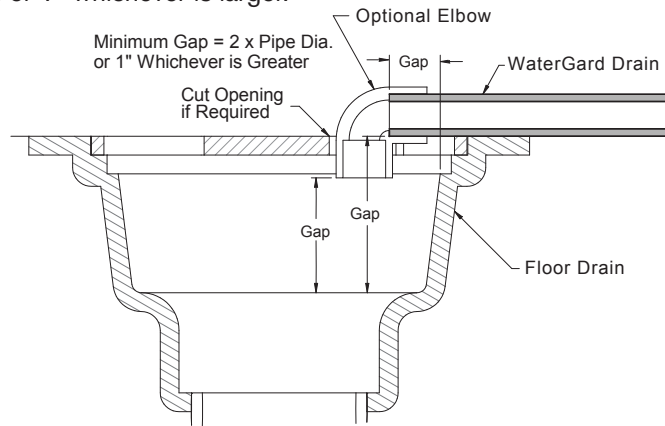

Figure 3

Startup and Operation

Note

WaterGard membranes cannot be used immediately, they must be filled with feed water and allowed to soak for a minimum of 30 minutes, see step 13.

⚠ Caution

Never completely close the waste stream, recirculating or pump discharge valve while the unit is running. Closing these valves beyond the minimum flowrates will cause irreparable damage to the membranes.

- 1 WaterGard and evaporative product arrangements should have been setup during the initial quoting. Refer to the Marley controls literature kit for configuration drawings and user manuals for laying out piping and electrical connections.
- 2 Connect the carbon filter (if present) to your potable water supply. The carbon filter will need to be flushed for 30 minutes before being piped into WaterGard.
- 3 If liquid chemical chlorine destruct is being used, setup the system upstream of WaterGard and plug in the chemical pump into the provided electrical receptacle on the WaterGard unit. See the installation drawing in the WaterGard literature kit for additional information.
- 4 Connect WaterGard to your potable water supply downstream from the carbon tank or chlorine destruct. If blending both warm and cold water to improve product flow rate, do not exceed 77°F.
- 5 Verify the installation of the sediment filter cartridge(s) inside its housing.

operation

- 6 The reject to drain connection coming out of the WaterGard system is for reject water. The water from this will go directly to the drain.
- 7 Connect the WaterGard product permeate line to the evaporative product's makeup line. In the case of a single WaterGard unit to a single evaporative product/makeup supply point, no additional external makeup valve is needed. All other configurations require a makeup solenoid valve to be installed at the evaporative product and connected to a Marley control panel. See configuration drawings in the literature kit for more information.
- 8 Connect WaterGard to a dedicated electrical power supply. Refer to unit nameplate for voltage information.
- 9 Connect the WaterGard LLC controls makeup and low-level alarm into the appropriate lead suspended from the WaterGard LLC control panel. If local code prevents the use of these leads refer to the configuration drawings within the literature kit for terminal block locations.
- 10 In cases where it is not desired to fill the evaporative unit's collection basin, a jumper will need to be added to the low-level alarm contact in either the LLC control panel or the WaterGard control panel.
- 11 Open the WaterGard feedwater inlet valve.
- 12 Turn on power at the disconnect on WaterGard control panel.
- 13 Press the WaterGard control button to the ON position. Then immediately press the "Manual Run/Flush" button twice to activate the flushing operation. Continue this until water flows stabilizes in the flow meters. Once this occurs turn the WaterGard off by pressing and holding the system On/Off button. Let the membranes soak for a minimum of 30 minutes.
- 14 Press the WaterGard control button to the ON position. A 10 second pump delay will occur before the pump starts and normal operation occurs.
- 15 Once the pump has started, membrane inlet (pump) pressure should never exceed 135 psi. Use the valve on the discharge side of the pump to adjust the pressure to 105 psi. If pressures over 135 psi are observed it could be an indication of membrane fouling. Refer to the **Membrane Replacement** section in this manual.
- 16 Allow WaterGard to run for 30 minutes to allow components to fill with water, purge trapped air and to rinse the membranes of preservatives.
- 17 While purging, adjust the reject throttle valve and adjust to a 50:50 ratio flow through the reject flowmeter compared to the product permeate flowmeter. See **Figure 4**. 

operation

- 18 Once WaterGard has stabilized and all impurities and preservatives have been flushed, the water will have to stabilize. Set the product permeate water quality alarm value at the desired limit (Refer to the **Controller Adjustments** section) and adjust the reject throttle to maximize water savings. Ensure the flowrate doesn't pass the stated minimum flowrate on the WaterGard nameplate.
- 19 When WaterGard is running stable and within desired water quality limits, the product permeate hose or piping can be connected to the process system's piping or evaporative product's collection basin. During the initial fill of the system, the low-level alarm will be activated, this is by design. This allows for a rapid fill of the system. During this phase, unfiltered feedwater will be added to the system until the LLC signals WaterGard to turn off.
- 20 Record initial operating conditions on the System Log sheet in this manual and then periodically afterwards as determined by your Quality Department or Facilities Manager.
- 21 Use the provided valve locks to ensure valve positions don't change

Note

The operating conditions should be recorded at least once each day WaterGard is operated.

System Shutdown

Less than 30 days. Press and hold the SYSTEM ON/OFF key (the display will show POWER OFF).

More than 30 days. Drain the system of as much water as possible by breaking unions or removing tubes. On startup, follow **Startup** procedure.

Automatic System Standby and Restart

System will automatically go into standby during the following conditions:

- Collection basin full
- Low inlet pressure

Once the collection basin water level drops below its actuation point WaterGard will restart.

operation

Bypass

System will automatically go into bypass during the following conditions:

- When WaterGard is in a shutdown condition
 - Low inlet pressure and has faulted 5 times or more
 - Pretreat fault has been active for more than 2 seconds
- When the LLC low level alarm has been activated

WaterGard Controls



Figure 4

1 - Controller	7 - Membrane Inlet Pressure psi
2 - Product Permeate Flow Meter	8 - Reject Pressure psi
3 - Reject Flow Meter	9 - Sediment Filter Inlet Pressure psi
4 - Recirculation Flowmeter	10 - Sediment Filter Outlet Pressure psi
5 - Inlet Feedwater Sample Port	11 - Reject Flow Control Knob
6 - Product Permeate Water Sample Port	12 - Recirculation Flow Control Knob
Item 10 – Item 9 = Differential Pressure	

operation

Controller Operation

The unit has two modes of operation, a power off mode and an operating mode that are controlled by the SYSTEM ON/OFF key. In the power off mode, the unit is effectively off. All outputs are turned off and the display shows POWER OFF. In the operating mode, the unit operates automatically. All inputs are monitored, and the outputs are controlled accordingly. Pressing and holding the power key will toggle the unit from the operating to power off or from power off to operating. If power is removed from the unit, when power is reapplied, the unit will restart in the mode in which the power was removed.

Operating Status Messages

The main operating status of the unit is shown on the top line of the display:

POWER OFF: The unit is off.

RO RUNNING: WaterGard unit is operating.

RO STARTING: WaterGard unit is starting up.

TANK FULL: The unit is shut down due to a collection basin full condition.

PRETREAT: The Unit is shut down due to a pretreat lockout condition.

PRESS FAULT: The unit is shut down to a low-pressure fault condition.

The secondary operating status is shown on the second line of the display.

SYSTEM FLUSHING: WaterGard flush is active. The number is the minutes remaining in the flush cycle.

PUMP DELAY: The unit is in the WaterGard start delay. The number is the seconds remaining before the WaterGard pump starts.

Temperature—The current permeate water temperature is shown on the second line. If equipped, the line will alternate with feed temperature.

Conductivity—The permeate conductivity is shown on the second line. If equipped, the third line will show feed conductivity. These values will alternate with water temperature on second line and percent rejection on third line.

WaterGard Runtime—The current operating hours are shown on the bottom line. See **Figure 5**.

operation

Figure 5

```
RO Running
Permeate Cond 87µS
Feed Cond 436µS
RO Runtime 00037 HRS
```

Figure 6

```
RO Running
Water Temp 72°F
Percent Reject 75%
RO Runtime 00037 HRS
```

Warning Messages—Warning messages are also shown on the second line. If any warnings are active, the active warnings will alternate with normal displays for the bottom line.

Tank Full Operation—The unit can be operated with either the hanging probe Marley LLC or ultrasonic Marley LLC+u water level controls. Refer to the WaterGard LLC water level control User Manual for more information. When the water level sensor has been active for 5 seconds, the unit will shut down on tank full. TANK FULL will show on the display. When the tank full condition clears, the unit will come out of standby. The number is the tank full restart time and the unit will restart when this delay times out.

Pressure Fault—If the pressure fault input becomes active (opens) and stays active for the number of faults programmed (see **Standard Setpoints** on page 21 for default settings), the unit will shut down for a pressure fault with internal bypass activated. The display will show SERVICE FAULT – LOW FEED PRESSURE, and the audible alarm will sound.

Low Pressure Auto Reset—If a pressure fault shut down occurs and the Auto Reset Setpoint is programmed to 0, the unit will remain shut down until manually reset. If the Auto Reset Setpoint (see **Standard Setpoints** on page 21 for default settings) is programmed to a value greater than 0, the unit will automatically clear the pressure fault and attempt to restart after this delay times out. If the number of consecutive pressure faults that occur is more than the allowed number, full shutdown of the unit will occur, and the internal bypass will be activated.

Pretreat—If the pretreat input becomes active (closes) and stays active for 2 seconds, the unit will shut down in a pretreat lockout condition. PRETREAT will show on the display and the unit will remain shut down with the internal bypass activated as long as the pretreat input is active.



operation

Product Water High Conductivity—If the conductivity reading exceeds the limit programmed COND limit setpoint for the delay programmed in the conductivity product water setpoint, the HI COND warning message will show on the display. This warning will clear when the conductivity drops below the setpoint. This should be set at 35% of the incoming water conductivity. Follow instructions in **Controller Adjustments** on page 18 to change the permeate alarm value if necessary.

When the High Conductivity warning message is active, the WaterGard alarm will be active until the product water conductivity goes back into the acceptance quality range.

Alarm Output—The board Divert/Alarm has been programmed to operate as **Standard Setpoints** on page 21 shows, the relay will energize whenever a shutdown condition occurs. The relay will remain energized if the shutdown condition is active. S1 should be left as a powered output for the bypass feature to function.

Cross Reference Terms on Controller Screen

Tank—Refers to the water collection basin in the tower

Permeate—The water after having gone through the WaterGard membranes

RO—References WaterGard

Fault Condition Display

High Pressure Fault: Occurs when High Pressure Switch Closes

Line 1—Service Fault

Line 2—High System Pressure

Line 3—

Line 4—To Reset Push OFF/ON

Low Pressure Fault: System is responding to low pressure condition per system settings

Line 1—Service Fault

Line 2—Low Feed Pressure

Line 3—

Line 4—Restart in MM:S”

operation

Pre Treat Fault: Pretreat Switch is closed indicating problem with the pretreat system

Line 1–Service Fault

Line 2–Pretreat

Line 3–

Line 4–Check Pretreat Sys

Permeate Conductivity Fault: Permeate conductivity is higher than the alarm setpoint

Line 1–Service Fault

Line 2–Permeate TDS xxx ppm or Permeate Cond xxx μ S

Line 3–Alarm SP xxx ppm or Alarm SP xxx μ S

Line 4–To Reset Push OFF/ON

Conductivity Probe Error messages:

Line 2 –Over-range

Measurement is out of range for the circuit, probe may also be shorted

Line 2–Probe shorted

Short circuit detected on temperature sensor in probe

Line 2–Probe not detected

Open circuit detected on temperature sensor in probe

Line 2–Probe Startup 1

Internal reference voltage too high to make valid measurement

Line 2–Probe Startup 2

Internal reference voltage too low to make valid measurement

Line 2–Probe Startup 3

Internal excitation voltage too high to make valid measurement

Line 2–Probe Startup 4

Internal excitation voltage too low to make valid measurement

operation

Controller Adjustment

With the system ON, press and hold the UP and DOWN arrows and then press System On/Off. **Figure 7** shows the settings that can be changed at the controller. ▶▶▶▶▶

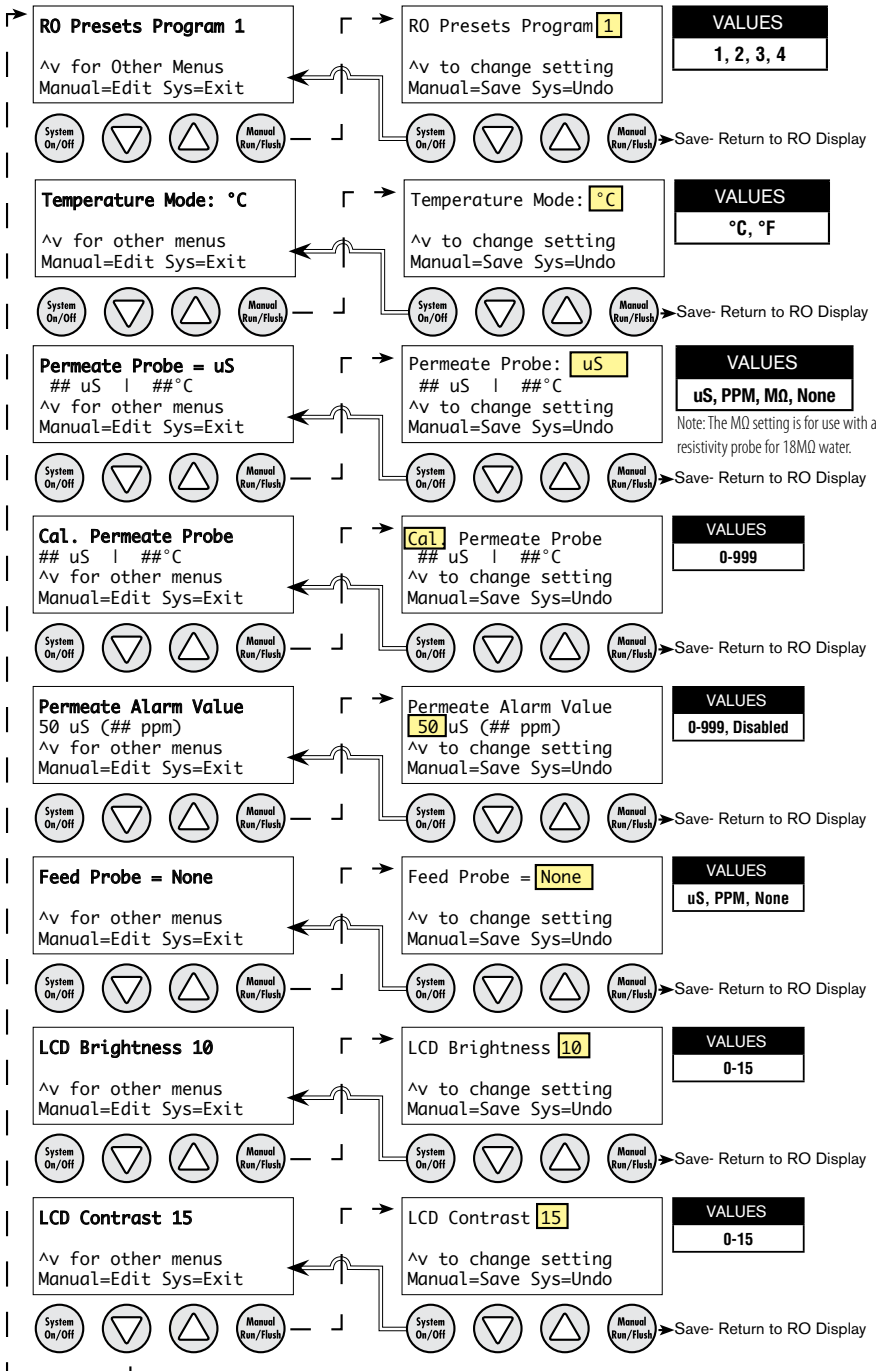

Figure 7

operation

WaterGard Presets Program—Change program to number of program desired. Setpoints are shown in **Standard Setpoints** on page 21.

Temperature Mode—Select temperature unit desired.

Conductivity Calibration

The controller has been calibrated prior to shipment. It may be necessary to periodically calibrate the conductivity. If the controller should require calibration, follow the instruction below. Please contact your local Marley sales representative, if you have any questions regarding the procedure.

Because the conductivity measurement is affected by the physical environment in which it operates, it is best to calibrate while installed in the system and operating under normal conditions. This requires an accurate external conductivity measurement device to serve as a reference.

- 1 Operate WaterGard long enough for the membranes, operating temperature and product permeate conductivity reading to stabilize, ideally at least 10 minutes.
- 2 Take a sample of the product permeate and measure it with the reference meter.
- 3 With the system ON, press and hold the UP and DOWN arrows. With the UP and DOWN arrows depressed, press the System On/Off button.
- 4 Enter the Permeate Calibration menu using the down arrow. Once at the menu, follow the on screen directions and use the UP or Down arrow until the value on the controller matches the value obtained on the reference meter.
- 5 Exit and save the calibration.
- 6 The same procedure applies to the Feed Probe calibration.

operation

Note

The probe calibration must be performed using solutions with conductivity of less than 900 ppm or μS . The conductivity calibration circuit will behave erratically if you attempt to calibrate using a higher value. When using a standard calibration solution, the NaCl ppm value can be used in place of the μS value if desired.

TDS to μS Conversions

Multiply	by	To Obtain
μS	1.9	TDS
TDS	.526	μS

Permeate Alarm Value—Select desired value to have permeate alarm at.

Display Adjustment—Change LCD brightness and LCD contrast to adjust for the application's best viewing experience.

operation

Standard Setpoints

Parameter	Value	Program 1	Program 2	Program 3	Program 4
Timed Manual Run	Minutes	5	5	5	5
Collection Basin Level Switch delay (actuation and de actuation)	Seconds	2	2	2	2
Pressure Switch delay (actuation and de actuation)	Seconds	2	2	2	2
Pretreat Switch delay (actuation and de actuation)	Seconds	2	2	2	2
Pump start delay	Seconds	10	10	10	10
Pump start retry interval (restart delay after LP fault)	Seconds	10	10	10	10
Inlet Solenoid stop delay	Seconds	1	1	1	1
Low pressure fault shutdown, number of faults	Faults	5	5	5	5
Low pressure fault shutdown, time to count faults	Minutes	10	10	10	10
Low pressure fault shutdown, reset after shutdown	Minutes	60	60	60	60
Low pressure timeout fault	Seconds	60	60	60	60
Flush Behavior		Low Pressure Flush	Low Pressure Flush	Low Pressure Flush	Low Pressure Flush
Startup Flush: Minutes from last flush	Minutes	0	0	0	0
Startup Flush: Duration	Seconds	0	0	0	0
Periodic Flush: Interval	Minutes	-	-	-	-
Periodic Flush: Duration	Seconds	-	-	-	-
Shutdown Flush: Time from last flush	Minutes	0	0	0	0
Shutdown Flush: Minimum operation	Minutes	0	0	0	0
Shutdown Flush: Duration	Seconds	60	120	180	240
Idle Flush: Interval	Minutes	0	0	0	0
Idle Flush: Duration	Seconds	0	0	0	0
Timed Manual Flush	Seconds	600	600	600	600
Alarm/Divert Relay*		Alarm	Alarm	Alarm	Alarm
WQ/Conductivity Shutdown Timer (0 = No Shutdown)		0	0	0	0

*Can be changed from controller. All other parameters require software changes. Contact your local Marley sales representative for assistance.

troubleshooting

⚠ Caution

Only those persons who have read the complete user manual or who have received authorization from the facility director should attempt to troubleshoot and/or repair the WaterGard system.

Trouble	Cause	Remedy
WaterGard will not start	WaterGard not supplied power	Reestablish power.
	Circuit breaker tripped	Reset the breaker.
System has power but no water flow	WaterGard in a FAULT condition	Check the WaterGard controller display for FAULT condition and correct the FAULT.
	Feed source not open	Open Incoming water valve.
	Feed pressure < 5 psi	Increase pressure to ≥ 30 psi.
Pump making excessive noise	Sediment filter clogged	Check the sediment filter gauges for pressure drop. Replace the sediment filter if the pressure drop is 10 psi.
	Feed solenoid is not operating	Test the solenoid. Replace the coil or valve if it is defective.
Pump making excessive noise	Low pressure or flow rate feeding WaterGard	Check the sediment filter outlet gauge psi (must be ≥ 20 psi), and verify that the product flow (flowmeter) is within range.
	Pump motor or impeller failing	Check membrane psi gauge to verify that it is within operating parameters. Replace the pump assembly if necessary.
Poor quality product water	High chlorine levels	Replace membranes. Verify carbon or pretreatment is removing all chlorine.
	Fouled membrane	Replace membranes.
	Conductivity cell out of calibration	Verify the conductivity cell accuracy with a known good meter. Follow the Conductivity Calibration procedures on page 19 or replace cell if necessary.
	Reject flow rate too low	Insure reject flowrate is above the minimum requirements as shown in Table 2 .
Low product flow rate	Low pressure feeding membrane	Verify that the incoming tap water supply is fully open.
	Low pump psi	Pump should be operating at 70-120 psi.
	Reject gpm flow rate too high	Turn reject flow to equal product flow with the throttle valve.
	Excessive PRODUCT line back pressure	Check for restrictions in the PRODUCT line.
	Low temperature incoming tap water	Consult temperature correction chart in Table 2 to determine if the flow rate is normal in relation to the feed water temperature.
	Sediment filter clogged	Check the sediment filter gauges for pressure drop. Replace the sediment filter cartridge if the pressure drop is ≥ 10 PSI.
	Fouled membrane	Clean or replace membranes.

controls troubleshooting

⚠ Warning

Hazardous voltages are present when power is applied to the unit. Care should be taken when troubleshooting any of the input power or output circuits. When disconnecting or connecting any board or accessory, verify that power is off.

Before contacting SPX Cooling for technical help, verify the programming of all setpoints, check the display and the status of all lights and indicators. The more information available when you contact us, the easier it will be to determine the source of the problem.

Trouble	Cause	Remedy
System Inoperative	Verify power is applied to the power terminals L1 and L2.	If yes, check/replace the main fuse with Littelfuse 0234006P and check/replace CPU fuse with Littelfuse 0218.250P. If no, ensure WaterGard is plugged in.
Display Blank	Is system operational?	If no, refer to above. If yes, check ribbon cable and adjust display contrast and brightness.
Inlet Valve will not operate	Is the system in power off? Is the inlet LED lit?	Power on system. If yes, verify power at inlet terminals. If no, replace board.
WaterGard pump will not operate	Is the system in power off? Are any shut down conditions active?	If no, check power at pump. If yes, power on. If no, check power at pump. If yes, correct fault.
No or incorrect conductivity reading	Is sensor wired correctly?	If no, correct wiring.

maintenance

Note

⚠ Warning

Servicing

If any component of the water treatment system is changed or replaced, the user should conduct appropriate tests to ensure that the revised system meets all standards to which it was initially tested.

Always remove WaterGard from the power source and turn off the water prior to any maintenance activities!

- 1 A daily/weekly **System Log** for the WaterGard system must be filled out completely each time the system is used. See page 29.
- 2 The membranes, carbon and sediment filter are non-durable components and will need to be exchanged periodically.
 - a. The membranes will need to be cleaned or replaced when the flow of product water decreases more than 15-20% assuming the water temperature remains constant, and no other issue is the root cause.
 - b. The 5-micron sediment filter will need to be replaced whenever the differential pressure on the outlet is 10 psi or greater than the pressure on the inlet of the filter housing.
- 3 The accuracy of the conductivity display should be verified with a calibrated, hand-held meter at least annually. If the conductivity display is not within 5% of the hand-held meter readings, the controller should be calibrated in accordance with the procedures in **Controller Adjustments** on page 18.

System Preparation for Maintenance

- 1 Press the SYSTEM ON/OFF key (the display will show POWER OFF).
- 2 Turn off the main power switch to the system.
- 3 Unplug WaterGard line cord.
- 4 Turn off the potable feed water supply to WaterGard.
- 5 Relieve the pressure from the system by opening the sample port on the front of the WaterGard unit.

maintenance

Typical Service Intervals		
Task	Frequency	Estimated Replacement Time
Membrane replacement	Yearly or as quality degrades to be more than 35% of incoming conductivity, whichever comes first.	15 minutes per membrane
Sediment filter replacement	Quarterly or when ΔP across Sediment filter is ≥ 10 psi.	5 minutes
Carbon filter replacement	Yearly or as chlorine starts to pass through. Refer to feedwater requirements for acceptable level.	5 minutes

Membrane Replacement

- 1 Shut off feedwater supply and drain unit of water by using the product and inlet sample ports. Check to ensure 0 psi on the sediment filter gauges.
- 2 Remove stainless steel clamps by loosening the two bolts using 14mm wrenches or sockets.



Figure 8

- 3 Remove end cap. It may be tightly sealed and require some force to remove. Use a flat object and carefully pry up around the cap. For models where the cap has a crossover tube to another membrane, it is best to remove both end caps at the same time.



maintenance

- 4 Apply plumbers silicone grease to all O-rings on end caps.
- 5 Lift old membrane out of housing.
- 6 Apply plumbers silicone grease to the brine seal O-ring on the new membrane. This is the large O-ring on the feed end.

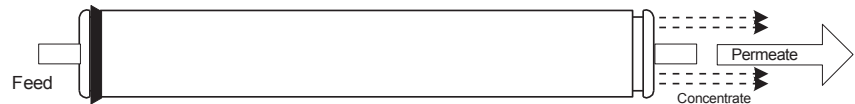

Figure 9

- 7 Match the flow direction arrow on the membrane with the flow direction arrow on the membrane housing and insert until seated.
- 8 Reattach end cap, tighten bolts, turn feedwater back on.
- 9 Soak the membranes for 30 minutes before use, see **Startup and Operation** on page 10 for more info.
- 10 Return to normal operation and ensure membrane inlet pressure is set to 105 psi.

Sediment Filter Replacement

- 1 Shut off feedwater supply and relieve pressure on the sediment filter housing by opening the inlet sample port. Check to ensure 0 psi on the sediment filter gauges.
- 2 Using the provided wrench, twist the sediment filter housing to the left to remove.
- 3 Lift old filter out of the housing.
- 4 Insert new filter.
- 5 Reinstall the filter housing, taking care to ensure the filter is vertical. If it feels like you are forcing the housing into place, the filter is not vertical and seating in the top cap.
- 6 Turn feedwater back on, and return to normal operation.

maintenance

Carbon Filter Replacement

- 1 Turn off the feedwater supply to the system by shutting off the inlet and outlet valves.
- 2 Press the red pressure relief valve and unseat the snap ring.



- 3 Remove snap ring.
- 4 Lift top cap.



Figure 10

- 5 Lift old cartridge from housing
- 6 Place new cartridge in housing.
- 7 Reinstall top cap and snap ring.
- 8 Turn feedwater back on flush carbon for 30 minutes, see Item 1 in **Startup and Operation** on page 10 more info.
- 9 Return to normal operation.

parts list

Note

Contact your Marley Sales Representative or SPX Cooling for pricing.

Part Number	Description
WaterGard Membrane	
2800054	Replacement Membrane 4" x 40"
2800055	End Cap O-Rings
2800056	Permeate Port O-Ring
2800057	Stainless Steel Clamp with 14mm bolts
2800058	Plumbers Silicone Grease
2800059	WG002 and WG004 End Cap
2800060	WG007 and WG009 End Cap
2800064	Crossover Tubing
2800061	Permeate Fitting
2800062	WG002 and WG004 Feed fitting, 0.5" MPT x 0.625" tube
2800063	WG002 and WG004 Feed fitting, 0.625" tube x tube
2800065	Test Strips for Measuring Residual Chlorine
Sediment Filter	
2800066	WG002 and WG004 5-micron Sediment Filter Cartridge
2800067	WG002 and WG004 Sediment Filter Housing
2800068	WG002 and WG004 Sediment Filter Housing Wrench
2800081	WG007 and WG009 5-micron Sediment Filter cartridge
2800082	WG007 and WG009 Sediment Filter Housing
2800083	WG007 and WG009 Sediment Filter Housing Wrench
Carbon Filter (option)	
2800069	Carbon Filter Cartridge
2800070	Snap Ring
2800071	Filter Cap
2800072	O-Rings
Miscellaneous	
2800076	WG002 and WG004 Pump
2800084	WG007 and WG009 Pump
2800077	Main Fuse
2800078	CPU Fuse
2800079	Terminal Board (TB-5)
2800080	Board with Screen (CPU-4)
Replacement Kits	
2800102	WG002 Membrane Replacement Kit (annual kit)
2800103	WG004 Membrane Replacement Kit (annual kit)
2800104	WG007 Membrane Replacement Kit (annual kit)
2800105	WG009 Membrane Replacement Kit (annual kit)
2800115	WG002 and WG004 Carbon Replacement Kit (annual kit)
2800116	WG007 and WG009 Carbon Replacement Kit (annual kit)
2800120	WG002 and WG004 Sediment Replacement Kit (6 month kit)
2800121	WG007 and WG009 Sediment Replacement Kit (6 month kit)

WaterGard

USER MANUAL

SPX COOLING TECH, LLC

7401 WEST 129 STREET
OVERLAND PARK, KS 66213 USA
913 664 7400 | spxcooling@spx.com
spxcooling.com

10000022002_A | ISSUED 9/2024

©2023-2024 SPX COOLING TECH, LLC | ALL RIGHTS RESERVED

In the interest of technological progress, all products are subject to design and/or material change without notice.

