

OlympusV™ adiabatic cooling system

TWO-FAN-WIDE MODELS

INSTALLATION - OPERATION - MAINTENANCE

10000033768E ISSUED 5/2026

READ AND UNDERSTAND THIS MANUAL PRIOR TO OPERATING OR SERVICING THIS PRODUCT

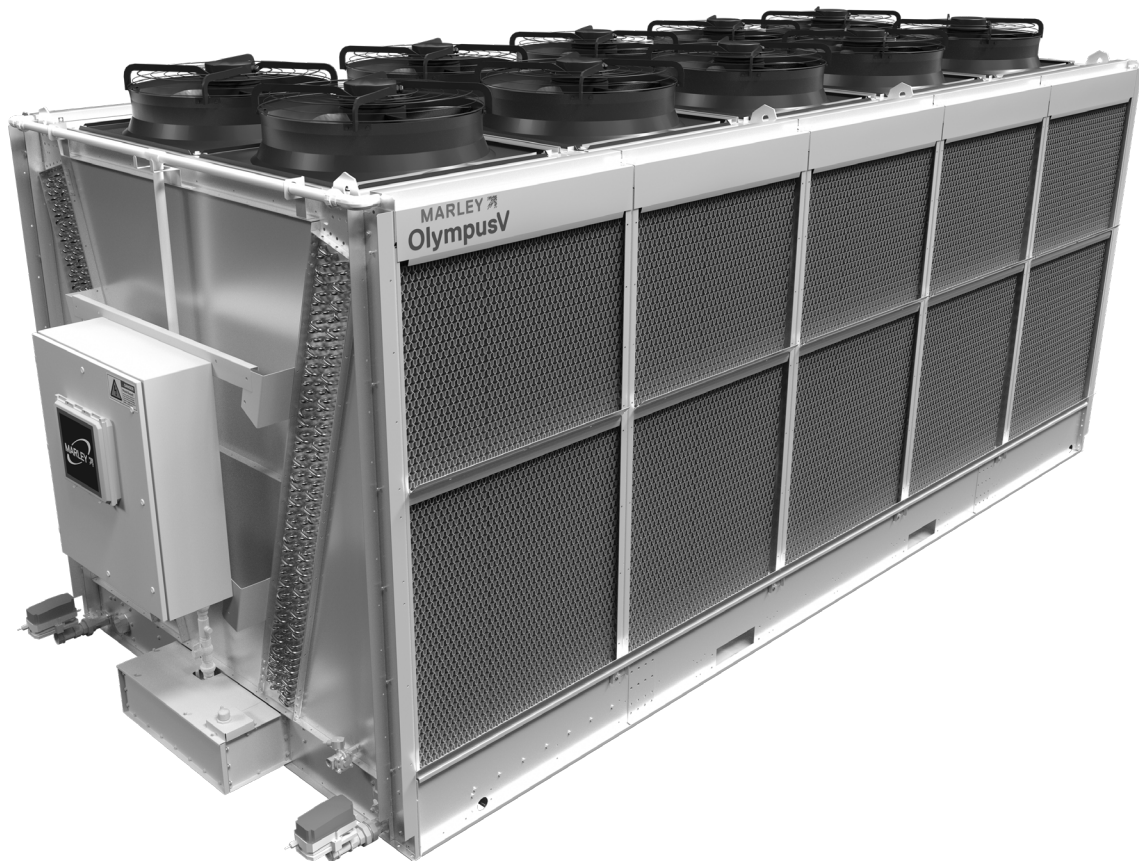

contents

Note

This manual contains vital information for the proper installation and operation of the OlympusV adiabatic cooling unit. Carefully read the manual before installation or operation of this unit and follow all instructions. Save this manual for future reference.

Unit Location.....	4
Receiving and Inspection.....	4
Coil Charge.....	5
Hoisting.....	5
Installation.....	6
Coil Connection.....	8
Operation.....	10
Water System.....	10
Maintenance.....	14
Interior Inspection.....	14
Pad Maintenance and Replacement.....	14
Distribution Basin and Spray Pipe Inspection.....	17
Distribution Pipe Cleaning.....	18
Pump Screen Cleaning.....	19
Recirculation Pump Removal.....	20
Overriding Drain Valve During Power Loss.....	21
Coil and Collection Basin Inspection and Cleaning.....	23
Maintenance Schedule.....	24
Seasonal Shutdown Instructions.....	25

Note

The following defined terms are used throughout this manual to bring attention to the presence of hazards of various risk levels, or to important information concerning the life of the product. Also, please observe all Caution and Warning labels on the unit.

Warning

Indicates presence of a hazard which can cause severe personal injury, death or substantial property damage if ignored.

Caution

Indicates presence of a hazard which will or can cause personal injury or property damage if ignored.

Note

Indicates special instructions on installation, operation or maintenance which are important but not related to personal injury hazards.

overview

This User Manual as well as those offered separately on fans, valves, pumps, sensors and the control panel are intended to assure that this OlympusV™ Adiabatic Series cooling unit operates properly for the maximum possible time. Since product warrantability may well depend upon your actions, please read this User Manual thoroughly prior to operation.

Note

Use this manual in conjunction with the CoolBoost OptiAD Adiabatic Controls User Manual, SPX Cooling Tech document 1000027010.

This User Manual provides information regarding general cooling unit installation and operation. Any deviation from, change or modification to the User Manual, the original design conditions or the original intended use of the equipment may result in improper installation and/or operation of the unit.

Any such deviation, change or modification shall be the responsibility of the party or parties making such deviation, change or modification. SPX Cooling Tech expressly disclaims all liability for any such deviation, change or modification. The equipment shall be warranted in accordance with the applicable SPX Cooling Tech Certification of Limited Warranty.

Note

The maximum installed altitude for this cooling unit is 14,000 ft (4250m) above sea level.

If you have questions about the operation and/or maintenance of this cooling unit, and you don't find the answers in this manual, please contact your sales representative. When writing for information, or when ordering parts, please include the serial number shown on the cooling unit nameplate.

Safety First

The location and orientation of the cooling unit can affect the safety of those responsible for installing, operating, or maintaining the unit. However, since SPX Cooling Tech does not determine the location or orientation of the unit, we cannot be responsible for addressing those safety issues that are affected by the unit's location or orientation.

The following safety issues should be considered by those responsible for designing the unit installation.

- Access to the fans located at the top of the unit
- Access to and from the maintenance access door
- The possible need for portable or fixed ladders to gain access to the fans or the maintenance access door
- The possible need for handrails or fall protection
- The possible need for external access platforms
- Access issues due to obstructions surrounding the unit



receiving

- Lockout of mechanical equipment
- The possible need for safety cages around ladders

Note

It is not intended nor assumed that access to the top surface of the unit is needed or necessary for maintenance of the unit.

This is only one of the safety issues that may arise in the design and placement process for the cooling unit. SPX strongly recommends that you consult a safety engineer to be sure that all safety considerations have been addressed.

Location

Space available around the unit should be as generous as possible to promote ease of maintenance and to permit freedom of airflow into and through the unit. Reference general arrangement instructions for guidance on minimum recommendations for clearances. Contact your sales representative for guidance and questions about the adequacy of the available space and the intended configuration of the unit.

Prepare a stable, level support foundation for the unit utilizing the weight, wind, seismic and dimensional information provided on the OlympusV™ Adiabatic Series drawings and instructions. Support must be level per the requirements of the submittal drawings to insure proper operation of the unit.

⚠ Caution

The cooling unit is not intended for operation by persons (including children) with reduced physical, sensory or mental capabilities, or lack of experience and knowledge, unless they have been given supervision or instruction concerning the use of this cooling unit by a person responsible for their safety. Children should be supervised to ensure that they do not play around this cooling unit.

⚠ Warning

The cooling unit must be located at such distance and direction to avoid the possibility of contaminated unit discharge air being drawn into building fresh air intake ducts. The purchaser should obtain the services of a Licensed Professional Engineer or Registered Architect to certify that the location of the unit complies with applicable air pollution, fire, and clean air codes.

⚠ Warning

Adiabatic units should be located away from areas exposed to sparks, welding or other “hot work” due to cellulose pad flammability.

Receiving and Inspection

Unless otherwise specified, OlympusV units ship by truck (on flat bed trailers), which allows the end user to receive, hoist, and install the unit in one continuous operation. Responsibility for the condition of the unit upon its

receiving

arrival belongs to the trucking company—as does the coordination of multiple shipments, if required.

Prior to unloading the cooling unit from the delivering carrier, inspect the shipment for evidence of damage in transit. If damage is apparent, note the freight bill accordingly. This information will need to be recorded to support any future recovery claim.

Coil Charge

Prior to shipment, the coils were charged with nitrogen gas at the factory to a value of 20 psig. This charge verifies that the coil is in good condition and has no leaks. Inspect the pressure gauge shipped on each coil header before the unit is removed from the truck.

Due to temperature changes, the pressure may be above or below the original 20 psig charge pressure. Once the coil pressure has been observed use the following table below to determine your actions:

Coil Pressure Reading	Action
15 psig	Coil good. Unload cooling unit.
0 psig on either coil	Coil has lost pressure. Do not unload the unit. Contact your sales representative to obtain clearance to return the unit to the factory
Pressure between 0 psig and 15 psig on either coil	Contact your sales representative for guidance.

Locate and remove the literature kit (installation instructions, drawings and bills of material) located in a plastic bag inside the unit. This information should be kept for future reference and maintenance purposes.

Hoisting

Hoisting instructions must be followed. Failure to follow the hoisting instructions may result in injury or death. For overhead lifts or where additional safety is required, safety slings should also be placed under the cooling unit.

The OlympusV unit has hoisting clips at the fan deck level for overhead lifting and handling. Hoisting clips are located at each endwall of the unit and every two fan-pairs maximum between the endwalls, incorporating a pair of clips. **All hoisting clips must be utilized during a lift.** Hoisting requirements and weight information can be found in two locations:

- A decal/label located on the unit endwall access door illustrates spreader bar length requirement, hoisting strap quantity, attachment points, and minimum hoisting strap length.



Warning

receiving

- A drawing with unit weights is also provided in the literature kit. Also reference the shipping information to obtain unit weight.
- Review all provided hoisting information prior to hoisting the unit. Remove the OlympusV unit from the carrier and hoist into place according to the instructions on the label and drawings.

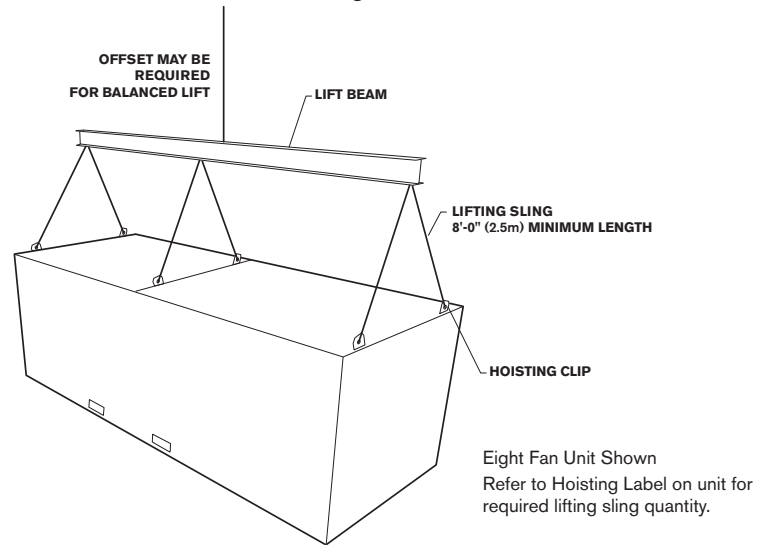

OlympusV units up to 21'-0 (6.4m) in length are also equipped with forklift slots for moving the unit. The forklift must have the appropriate lift capacity and fork spread which varies with unit length. The forks must extend 8'-0 (2.4m) into the fork openings. Insufficient inserted length of the fork may damage the unit. Units longer than 21'-0 do not have forklift openings and cannot be fork lifted.

⚠ Caution

Due to the potential length of the OlympusV, use of a fork truck should be limited to movement on smooth, level surfaces at slow speeds. Failure to follow this limitation may result in damage to the unit.

Installation

Note

Installation instructions are intended to help prepare the site before OlympusV cooling unit arrives. If discrepancies exist between these instructions and those shipped with the unit, the instructions shipped with the unit will govern.

- 1 Prior to placement of the unit, confirm that the supporting structure is level and that the anchor bolt holes are correctly located in accordance with the Supporting Steel Detail drawing instructions.

installation

- 2 Place the unit on the prepared support structure aligning bolt holes with those in the supporting steel. Verify that the unit orientation agrees with the intended piping arrangement. Attach the cooling unit to the supporting structure with customer supplied 1/2" diameter (M12) bolts and flat washers as per the Supporting Steel Detail drawing. Position the flat washers between the bolt head and the unit bottom frame flange. The quantity of bolts required will vary with the size of the unit.
- 3 Remove plywood/steel shipping panels from air inlet side of the unit and discard.
- 4 Open the access door by removing the plastic knobs and lifting the door out of the opening.



- 5 Remove all of the shipping wires between the interior X-bracing. Cut and discard. Re-install access door when complete. 

Shipping Wire



installation

- 6 Control Panel End of Unit—Connect piping to the 3" NPT overflow piping connection. Reference the provided Schematic Details drawing instructions for location of the connection.
- 7 Control Panel End of Unit—Connect piping to the 1¼" NPT make-up solenoid valve. Reference the provided Schematic Details drawing instructions for location of the connection.
- 8 Control Panel End of Unit—Connect piping to the (2) 2" NPT drain valves. Reference the provided Schematic Details drawing instructions for location of the connections.
- 9 Control Panel End of Unit—Wire the control panel. Refer to the provided *CoolBoost Opti AD Adiabatic Controls* User Manual.
- 10 Coil Connection End of Unit—Connect piping to coil connections. Details vary by configuration.

Coil Connection Configuration 1—Low-pressure

- 1 Configuration 1 supports the installation of a Victaulic coupling with a square groove supplied in the outside wall of the inlet and outlet pipe stubs.
- 2 Configuration 1 also supports welding supply and discharge piping directly to the coil inlet and outlet. A V-groove is supplied in the outside wall of the inlet and outlet pipe stubs to support direct welding.
- 3 Clip the Schrader valve off of the inlet and outlet pipe stubs and allow the nitrogen charge gas to discharge.

Warning

Adiabatic cellulose pads are flammable. When performing grinding or other "hot work" on adiabatic units steps should be taken to protect the adiabatic pads from accidental ignition from "hot work."

- 4 At the V-groove in each inlet and outlet stub pipe, use a grinding wheel or other cutting device to remove the capped end of the pipe.
- 5 Victaulic Coupling—Install the Victaulic flange using the square groove in the inlet and outlet pipe stubs per the manufacturer's instructions. Connect

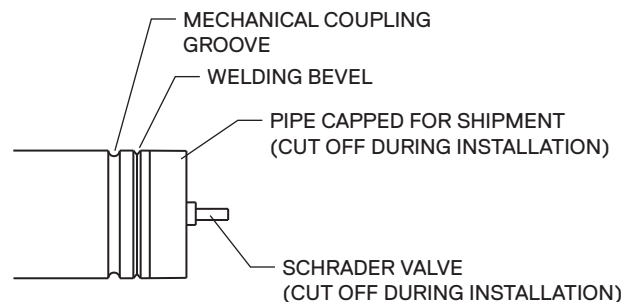

installation

supply and discharge piping.

- 6 Direct Weld—Design and size of the weld is the responsibility of others. Prepare the inlet and outlet coil pipe stubs and the customer supply and discharge piping as required and weld the piping directly to the beveled ends of coil stubs.
- 7 Do not support supply and discharge piping loads on the unit. All customer supplied piping must be supported independently.

Coil Connection Configuration 2—High-pressure

- 1 For the high-pressure application, the only acceptable method of coil connection is welding.
- 2 Clip the Schrader valve off of the inlet and outlet pipe stubs and allow the nitrogen charge gas to discharge.

⚠ Warning

Adiabatic cellulose pads are flammable. When performing grinding or other “hot work” on adiabatic units steps should be taken to protect the adiabatic pads from accidental ignition from “hot work.”

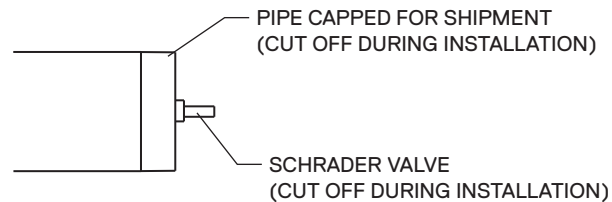

- 3 Using a grinder or other tool, cut the pipe to remove the capped end of the pipe.
- 4 Design and size of the weld is the responsibility of others.
- 5 Prep the inlet and outlet coil pipe stubs and the customer supply and discharge piping as required by the weld design and weld the piping directly to the coil stubs.
- 6 Do not support supply and discharge piping loads on the unit. All customer supplied piping must be supported independently.

operation

General Principal of Operation

The OlympusV Adiabatic Series cooling unit uses water evaporation to depress the dry-bulb temperature of the incoming air to achieve higher cooling capacity than air cooled products. Proper sizing of units is critical to minimize water/energy usage.

The OlympusV controls the process fluid outlet temperature/pressure by modulating fan speed and enabling adiabatic operation.

Stage 1 cooling is defined as fans-only operation.

Stage 2 cooling is defined as the addition of recirculating water over the adiabatic pads for dry bulb suppression. The unit is intended to be run in one of two possible automatic operating modes which prioritize either water or energy savings.

Water System

OlympusV controls are configured to periodically drain the water system negating the need for water treatment. The following features have been designed to mitigate the risk of uninhibited biological growth within the adiabatic product:

- Complete drain down of all water distribution piping after each adiabatic cycle
- Complete drying of the precooling media after each adiabatic cycle
- Complete drain down of the sump and piping daily, adjustable for varying site conditions
- Spray-free operation
- Potable supply water

Note

Maintain supply water temperatures at 68°F (20°C) or less to keep Legionella dormant. To minimize the presence of waterborne microorganisms, including Legionella, follow the water management plan for your facility and perform all regularly scheduled inspections and maintenance.

⚠ Warning

Microorganisms including Legionella bacteria can exist in premise plumbing including OlympusV cooling unit. The development of an effective water management plan (WMP) and implementation of maintenance procedures are essential to prevent the presence, dissemination and amplification of Legionella bacteria and other waterborne contaminants throughout premise plumbing. Establish and follow an appropriate water management plan and maintenance procedures before operating the adiabatic product.

The nightly drain cycle in the automatic modes for Stage 2 cooling is required and is essential to support a good water management plan.

operation

Concentrations of dissolved solids in the recirculating water are managed with an adjustable-setpoint conductivity-based blowdown control. To reduce the risk of scale and corrosion, maintain recirculating water quality parameters within recommended limits.

Circulating Water Condition Guideline			
Constituent	Units	Value	Contributes To
pH		6.0 - 9.2	Scale and Corrosion
Conductivity	µS/cm	< 3,300	Scale and Corrosion
TDS	ppm	< 2,050	Scale and Corrosion
M-Alkalinity	ppm as CaCO ₃	0 - 600	Scale
Calcium Hardness	ppm as CaCO ₃	50 - 750	Scale and Corrosion
Chlorides	ppm as Cl	0 - 300	Corrosion
Sulfates	ppm as SO ₄	0 - 250	Scale
Silica	ppm as SiO ₂	0 - 150	Scale
Iron	ppm as Fe	0 - 1	Scale
Manganese	ppm as Mn	0 - 0.1	Scale
(SiO ₂) x (Mg)	ppm	< 8400	Scale
TSS	ppm	0 - 25	Fouling

For a more detailed description of the control and operation of the OlympusV Adiabatic cooling unit please refer to *CoolBoost Opti AD Adiabatic Controls User Manual*.

Factors Affecting Operation

The fluid outlet temperate/pressure will vary with the following influences:

- **Heat load:** In Stage 1 and Stage 2 operation, if the heat load increases, the fluid outlet temperature/pressure will also rise.
- **Air dry-bulb temperature:** In Stage 1 and Stage 2 operation, if the ambient dry bulb temperature increases, the incoming air temperature will be higher resulting in a higher fluid outlet temperature/pressure.
- **Air wet-bulb temperature:** In Stage 2 adiabatic mode, if the ambient wet bulb temperature increases, the depression of the dry-bulb of the incoming air will be less, resulting in a higher fluid outlet temperature/pressure.
- **Air flow rate:** In Stage 1 and Stage 2 operation, reducing air flow through the unit will result in a higher fluid outlet temperature/ pressure.

operation

Freezing Weather Operation

⚠ Caution

The OlympusV Adiabatic unit and the recirculating piping should not contain water in the presence of freezing temperatures. Damage to the unit may result if recirculating water is allowed to freeze.

All customer supply and drain lines connected to the OlympusV that could contain water in the presence of freezing temperatures should have heat tracing. The design and construction of supply and drain piping is the responsibility of the owner and installing contractor.

The OlympusV Adiabatic unit should use only Stage 1 operation during freezing temperatures. The use of Stage 2 operation during freezing temperatures may damage the unit if the recirculating water in the piping, basins and adiabatic pads is allowed to freeze. When the controls system is in automatic operation modes, the system monitors the ambient air temperature and prevents the unit from Stage 2 operation and the use of recirculation water. Manual mode operation of the controls system when freezing temperatures are present may result in damage to the unit.

Coil Type	Min Fluid Pressure water/brine	Max Fluid Pressure water/brine
Low Pressure Coil—3" Nominal Header	0 MPa (0 psig)	2.76 MPa (400 psig)
Low Pressure Coil—4" Nominal Header	0 MPa (0 psig)	2.76 MPa (400 psig)
Low Pressure Coil—D Shape Header	0 MPa (0 psig)	1.72 MPa (250 psig)

Coil Fluid Type	Min Fluid Temperature	Max Fluid Temperature
Water	0°C (32°F)	93.3°C (200°F)
Brine/Glycol Mixture	Check specific fluid freezing point	93.3°C (200°F)

Coil Freeze Protection

Note

This section applies only to fluid coolers. Not applicable to refrigerant condensers or CO₂ coolers.

Coils are the most expensive components in the unit and must be protected from freezing and bursting. Industry best practice and SPX Cooling recommends using an industrial inhibited glycol process fluid of appropriate concentration to provide freeze protection. The two most common fluids used are Propylene Glycol (PG) and Ethylene Glycol (EG). PG has higher viscosity and thus has a larger efficiency penalty than EG, but PG's lower toxicity makes it preferable for most HVAC applications. Reference the glycol manufacturers' data sheet to determine the appropriate concentration for freeze protection (different

operation

than burst protection) at the lowest ambient temperature (including a safety factor) expected at the installation location—typically 20- 60% concentration. Higher glycol concentrations penalize the heat transfer efficiency and pumping energy more than lower concentrations. Be sure to consider concentration when making cooling unit and process-fluid pump selections. Below are some tips for dealing with glycol solutions:

- Glycol protection is needed in freezing climates from the time the system is filled to the time it is drained and/or retired. Even 24-hour operations are recommended to have glycol protection to prevent freezing during down times.
- Do not simply displace partial system volume with the required amount of glycol. Proper mixing and circulation is needed to distribute glycol evenly throughout the process fluid. Use quality water and mix according to glycol manufacturer instructions.
- Only use inhibited industrial glycols, do not use automotive or other-grade anti-freeze. Note the minimum concentration for inhibitor effectiveness. Do not mix glycol from multiple manufacturers.
- Check system glycol concentration regularly, especially before cold weather. If an industrial inhibited glycol solution of appropriate concentration is not in place, sufficient flow rate (minimum tube fluid velocity greater than 1 ft/s) and sufficient heat load (minimum coil exit temperature of 45° - 50°F) must be **always maintained during freezing conditions**. This possibly includes weekends, holidays, power outages, planned or unplanned shutdowns, or any other inconvenient time.

Though some operators may choose to drain cooling unit coils as a method to prevent freezing, SPX Cooling does not typically recommend draining as a standard operating procedure for freeze protection due to higher risk of complications. When conducting seasonal or periodic draining, proper system modifications must be in place to ensure quick, complete, and safe draining. Avoid draining (or re-filling) during freezing conditions. Stainless steel and copper coils can typically be drained without accelerating corrosion.

maintenance

Interior Inspection

⚠ Warning

Before entering the unit, ensure that power to the fans has been turned off and the power supply has been locked out. Failure to lock-out the fan power supply may result in serious injury or death.

The access door is located on the coil header end of the unit, opposite the control panel. The access door provides access to the unit interior allowing inspection and cleaning of the interior of the unit.

To open the access door:

- 1 Loosen and remove the two plastic knobs at the top of the door.
- 2 Using the provided handles, lift the door to clear the door bottom flange from inside of the opening.
- 3 To reinstall reverse these steps.



Air Inlet Pad Maintenance and Replacement

⚠ Caution

Pads can be easily damaged by rough handling.

The water-flow over the adiabatic pads at the unit air inlet should prevent significant scaling, but debris could gather on the pads requiring cleaning. With the fans off, a light brushing action may be used to remove leaves, etc. It is also possible to use the controls system to reverse the fans to assist in removing debris. If needed, the pads can be removed for cleaning. A light rinse with water can help remove debris. Avoid pressurized streams or jets of water that may damage the pads. Damaged or clogged pads should be replaced. When pads are new, water may bubble and drip from the face of the pads upon initial startup of the circulating water system. After an initial run-in period of wet operation, pads will achieve their normal water control characteristics.

maintenance

Warning

Adiabatic cellulose pads are flammable. When performing grinding or other "hot work" on adiabatic units steps should be taken to protect the adiabatic pads from accidental ignition from "hot work."

Air Inlet Pad Removal Steps

- 1 Upper pads are retained by the distribution basin cover attached with two black knobs. Unscrew both knobs counterclockwise.
- 2 The distribution basin cover can now be removed and allows access for the top pads to be removed. Remove one of the interior pads first.

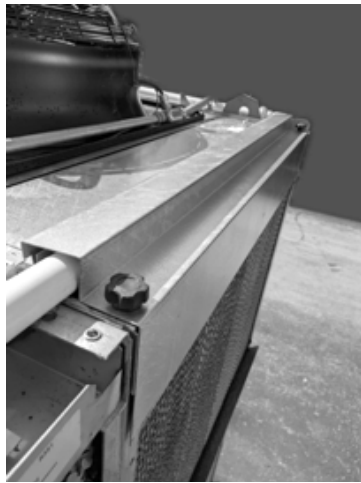

- 3 Lift and remove the interior pads from the mid-level distribution tray.

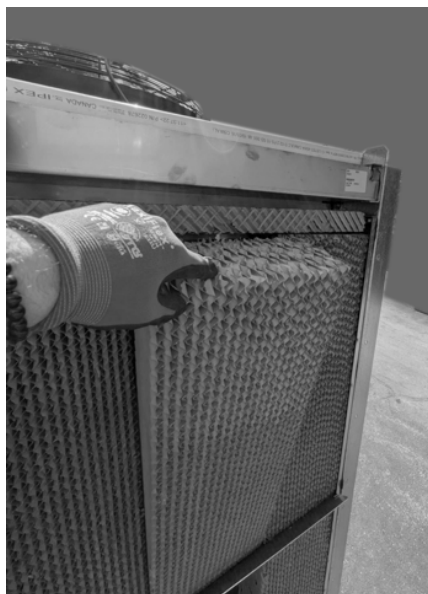

maintenance

- 4 End pads will need to be shifted inward to clear the end retaining channel.

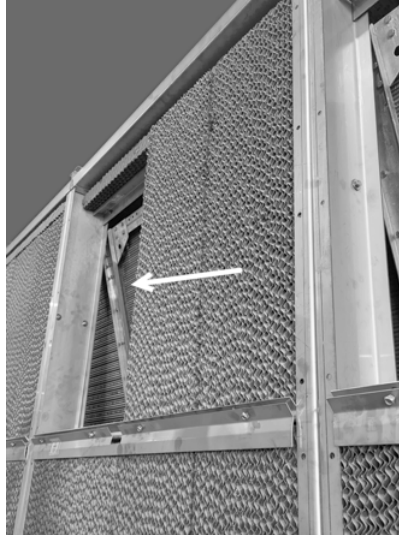

- 5 Lower pads are retained by a mid-level distribution tray and pad retainer. Remove two wing nuts and bolts to release the pad retainer.

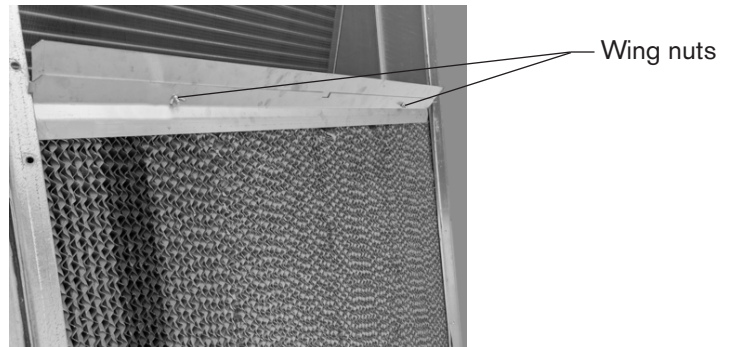

maintenance

- 6 Remove the pad retainer. Lower pads may now be removed in a similar fashion as in steps 3 and 4. To reinstall the pads or to install new pads, follow these steps in reverse.



Distribution Basin and Spray Pipe Inspection

Periodically it is necessary to ensure that the distribution pipe is free of debris.

- 1 Remove the distribution pipe cover by unscrewing the black knobs. 

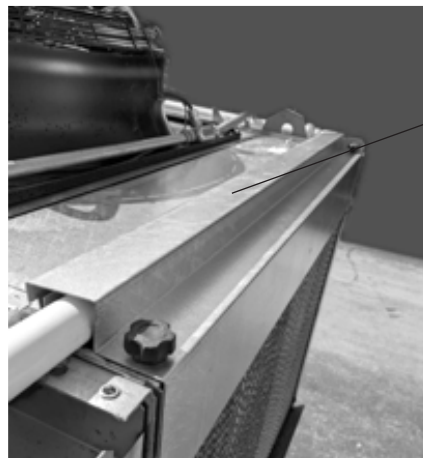

Distribution Pipe Cover

maintenance

- 2 With the recirculation pump operating, inspect the three spray pipe holes to ensure that each hole is free-flowing water into each basin.

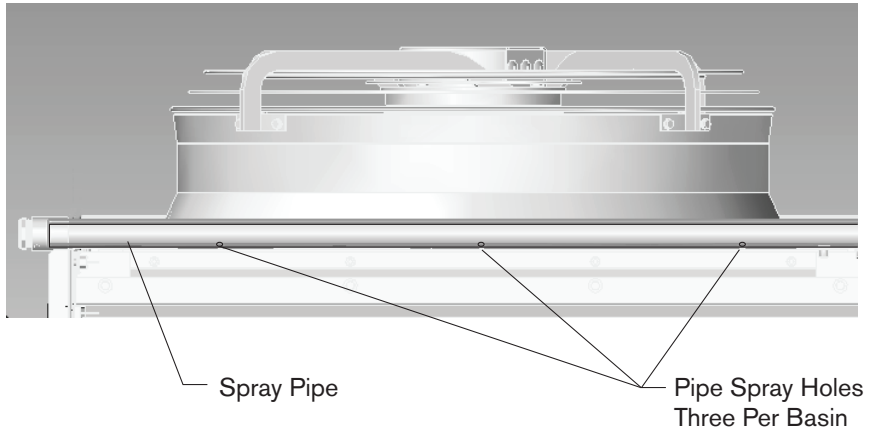

- 3 Also inspect the holes in the basin floor to be sure they are free from debris. Remove the upper pads in order to inspect the holes in the mid-level basin floor. Reinstall the basin covers when inspection is complete.

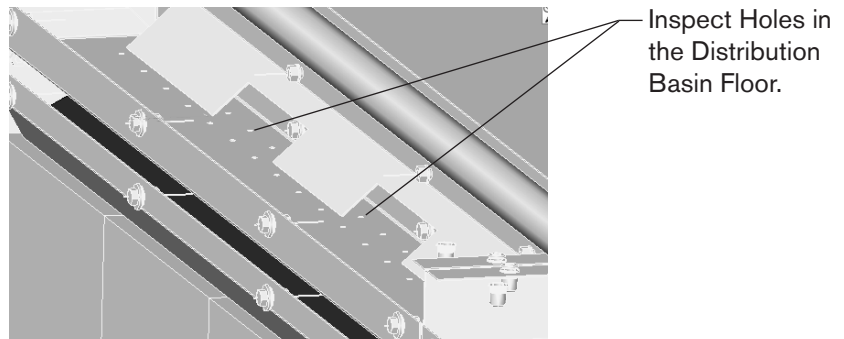

Distribution Pipe Cleaning

The vertical riser pipe contains a hose connection point to allow the distribution piping to be flushed with water.

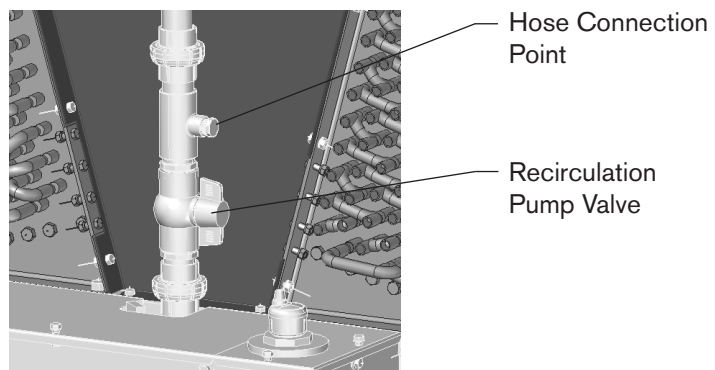

maintenance

- 1 Shut down the recirculation water system. Refer to the *CoolBoost Opti AD Adiabatic Controls* User Manual for instructions.
- 2 Close the recirculation pump valve by rotating the valve clockwise.
- 3 Remove the piping end-caps on the opposite end of the unit.

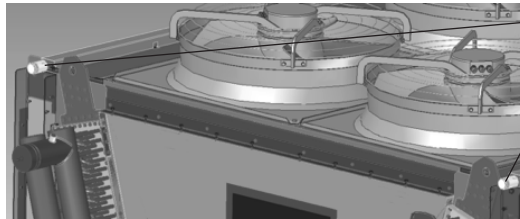

Distribution Piping
End Caps

- 4 Attach a hose or other water source to the hose connection point.
- 5 Flush the system to clear any debris in the piping system.
- 6 After completion, reinstall piping end caps and hose connection plug. Rotate and open the recirculation pump valve.

Pump Screen Cleaning

Always wear gloves when handling sheet metal. Failure to wear proper protective equipment can result in injury.

The recirculating pump is surrounded by a screen that must be periodically cleaned.

- 1 Shut down the recirculation water system. Refer to the *CoolBoost Opti AD Adiabatic Controls* User Manual for instructions.
- 2 Remove pump box cover bolts and remove the pump box lid.

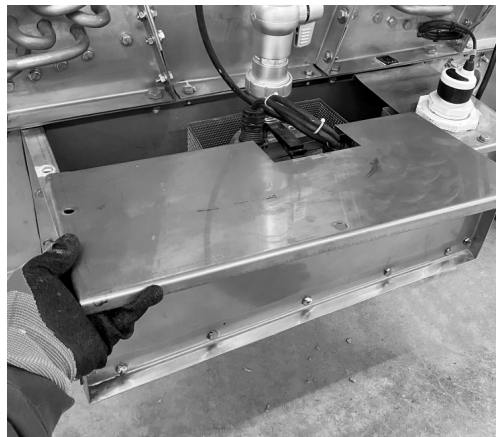

⚠ Caution

maintenance

- 3 Once the lid is removed the screen is accessible for cleaning. In most cases the screen will not need to be removed to clean.
- 4 To completely remove the screen, remove the bolts joining the screen halves together.

Screen joining bolts



Recirculation Pump Removal

To access the recirculation pump for cleaning or replacement.

- 1 Shut down the recirculation water system. Refer to the *CoolBoost Opti AD Adiabatic Controls* User Manual for instructions.
- 2 If the pump is to be completely removed from the unit, disconnect power to the unit control panel and lock and tag out the power supply. After power has been disconnected to the pump, wiring can be removed from the control panel.

⚠ Warning

Before disconnecting the pump, ensure that power to the control panel has been turned off and that the power supply has been locked out. Failure to lock out the control panel power supply may result in serious injury or death.

- 3 Remove pump box cover bolts and remove the pump box lid.
- 4 Remove the retaining bar bolts and remove the retaining bar. The screen does not need to be removed.

Retaining Bar Bolts

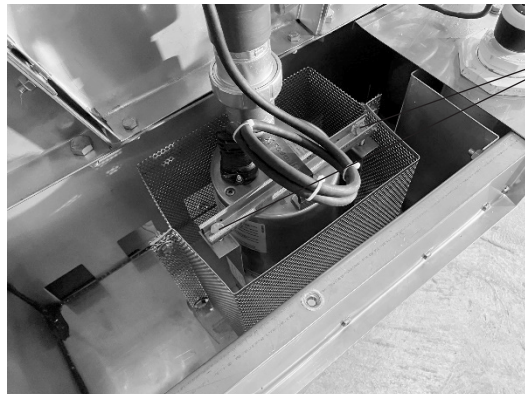

maintenance

- 5 Loosen the pipe union above the pump and remove the pump.



Overriding Drain Valve During Power Loss

The actuator on the drain valve(s) are fail-in-place. Manually closing the valve may be required if power is lost. Follow these steps to disengage the actuator and manually operate the valve.

- 1 Using a screwdriver or similar device, depress the manual override button on the top of the cover. This disengages the actuator.
- 2 Insert a second screwdriver into one of the holes in the black plastic casting located under the housing, above the valve. **The manual override button must be depressed.** The manual override button can be locked in the depressed position by rotating the screwdriver clockwise.



maintenance

⚠ Caution

Do not rotate the plastic casting without the manual override button depressed. Damage to the actuator can result.

- 3 Keeping the manual override button depressed, rotate the black plastic casting to the desired position using the screwdriver for leverage.

The valve closes with clockwise rotation when viewed from above.

Note



- 4 Verify that the manual override button pops up flush with the top of the cover after work is complete. It may be necessary to rotate the button counterclockwise using the screwdriver to free the button from the locked position.



Manual Override Button
Must be Flush with Top of
Cover

⚠ Caution

Failure to free the manual override button will prevent the actuator and the controls system from operating the valve. Damage to the unit may result.

maintenance

Coil and Water Collection Basin Inspection and Cleaning

Coils should be inspected periodically to ensure good airflow. The primary concern for coils would be debris clogging the fins on the air intake side of the coils and the development of any corrosion due to environmental conditions.

To inspect the fins, remove the adiabatic pads as outlined in the **Pad Maintenance and Replacement** section.

Caution

The aluminum fins are sharp. Injury may result if fins are touched. The aluminum fins are also easily damaged. Avoid touching the fins with your hands or other hard objects.

Once the pads are removed the aluminum fins on the coil should be inspected for debris. The openings between the fins should be open and regular in pattern. To remove debris, use a soft bristle brush with a light action moving with a vertical action parallel to the fins. Scrubbing the fins in a horizontal direction may cause the fins to be damaged.

Debris that has gathered in the water basin of the unit between the pads and the coil should be removed by hand or with a vacuum. Once debris is removed wipe down the floor and basin surfaces.

Warning

Before entering the unit, ensure that power to the fans has been turned off and that the power supply has been locked out. Failure to lock out the fan power supply may result in serious injury or death.

Remove the access door and inspect the interior of the coils and the interior floor and basin. To aid coil cleaning, it is acceptable to gently spray water from the unit interior onto the coil fins to loosen debris on the air inlet surface. Do not use high pressure hose or a pressure washer. Spray water only in the horizontal direction. Failure to do this may result in fin damage.

Damaged fins may be straightened using a fin comb. The coil has a 10 fins per inch (0.1" or 2.5mm fin spacing). Be sure to use a fin comb appropriate for this spacing.

If there appears to be significant scaling on the fins, consult your sales representative for assistance.

Remove any debris from the interior floor and basin of the unit by hand or with a vacuum. Once debris is removed wipe down the floor and basin surfaces.

Reinstall the access door and pads after coil and unit maintenance is complete.

maintenance

Maintenance Schedule

The maintenance intervals for the components can vary. While the coil may be used throughout the year, it is possible that the recirculation system and the fan may only be used during a portion of the year for cooling.

In the Maintenance Service Table the intervals listed should be interpreted as follows:

Monthly—If this component in the table is in regular use, the maintenance service listed should be conducted every month. If the component is not being used for a period longer than 60 days it is not necessary to conduct the monthly maintenance service.

Semi-annual—This maintenance service should be conducted two times per year at approximately six-month intervals.

Annual—If the component listed is in continual use through the year, the maintenance service described should be conducted once per year.

Seasonal Startup—If the component listed is not used for a 60 day or greater period, then the service described should be conducted prior to or during the startup process for the component.

Maintenance Service	Monthly	Semi-annually	Seasonal Startup	Annually
Inspect General Condition and Operation	x		x	
Observe Operation of:				
Fans—Inspect wiring connections and observe that fans are in operation when appropriate and is operating in correct direction by observing airflow direction. Fans operate in Stage 1 cooling and Stage 2 cooling.	x		x	
Recirculation Pump—Inspect wiring connections and observe that the pump is in operation when appropriate. Note—the pump only operates for Stage 2 cooling.	x		x	
Water Makeup Valve—Inspect wiring connections and observe that the makeup valve is in operation during Stage 2 cooling. This valve supplies water into the unit and removal of pads is required to inspect operation.	x		x	
Drain Valve—Inspect wiring connections and observe that the drain valves are operating properly during Stage 2 cooling. This valve removes recirculating water from the unit.	x		x	
Inspect for Unusual Noise or Vibration	x		x	
Inspect and Clean:				
Air inlet pads	x		x	
Coils		x	x	
Distribution basin and spray pipe		x	x	
Water collection basin		x	x	
Recirculation pump screen and pump exterior	x		x	
Fan:				
Check for loose fasteners between the fan and the unit. Tighten as required		x	x	
Check for loose fasteners on the fan and motor. Tighten as required		x	x	
Check fan blade tip clearance			x	
Unit Structure:				
Inspect/tighten all fasteners		x	x	
Inspect and touch-up all metal surfaces				x
Controls:				
Inspect condition of exterior surfaces of the control panel enclosure. Address any deterioration and touch up all metal surfaces				x
Inspect wiring connections following all appropriate safety procedures			x	x
Refer to the CoolBoost <i>Opti Ad Adiabatic Controls</i> User Manual (part number 10000027010) for additional control panel maintenance requirements			x	x

maintenance

Seasonal Shutdown

Water System: When the cooling unit is to be shut down for an extended period of time, it is recommended that the cooling unit basin and piping be drained. Drain line valves should be open so rainwater or snow melt may drain from the unit. Operating the controls system in automatic mode with an ambient adiabatic shutoff temperature setting above 45°F (default controls setting) ensures that the unit is drained for freezing temperatures. It is recommended that users visually verify that the unit is drained at seasonal shutdown.

Coil: See Coil Freeze Protection section.

Air Inlet Pads: Inspect for damage or excessive scaling. Replace pads in poor condition with new pads.

Structure: Inspect metal surfaces for evidence of damage or corrosion. Apply local touch-up coating as needed for damaged galvanized coatings. Excessively damaged or corroded parts should be replaced.

Galvanized steel (zinc coating) requires a zinc-rich paint for touch-up. Contact the manufacturer of the coating you intend to use for instructions.

Check structural bolted connections and tighten as required.

Fan and Motor Assembly: Check fan assembly hardware and tighten as required.

Prolonged Shutdown: If the shutdown period is longer than seasonal, contact your sales representative for additional information.

OlympusV

USER MANUAL

SPX COOLING TECH, LLC
7401 WEST 129 STREET
OVERLAND PARK, KS 66213 USA
913 664 7400 | spxcooling@spx.com
spxcooling.com

10000033768 E | ISSUED 5/2026
©2025-2026 SPX COOLING TECH, LLC | ALL RIGHTS RESERVED
In the interest of technological progress, all products are subject to design
and/or material change without notice.

