

OlympusMAX™ adiabatic/dry cooler

INSTALLATION - OPERATION - MAINTENANCE

10000034965 G ISSUED 5/2026

READ AND UNDERSTAND THIS MANUAL PRIOR TO OPERATING OR SERVICING THIS PRODUCT

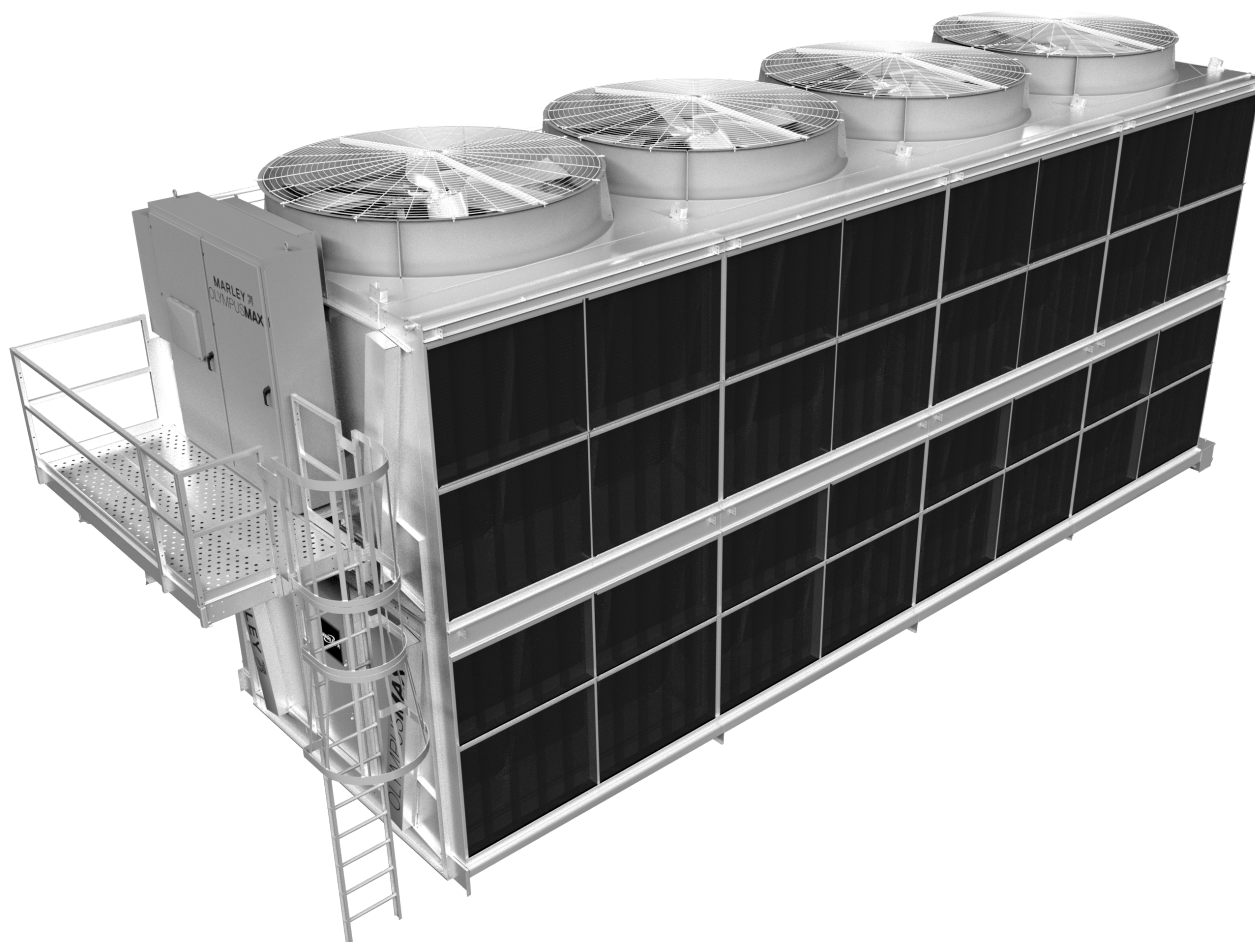

contents

Note

This manual contains vital information for the proper installation and operation of the OlympusMAX Adiabatic/Dry cooling unit. Carefully read the manual before installation or operation of this unit and follow all instructions. Save this manual for future reference.

| | |
|--|----|
| Unit Location | 4 |
| Receiving and Inspection | 5 |
| Coil Charge | 5 |
| Hoisting | 5 |
| Installation | 6 |
| Coil Connection | 8 |
| Mechanical Equipment | 9 |
| Operation | 10 |
| Maintenance and Interior Access—General | 10 |
| Coil Inspection and Cleaning—General | 14 |
| Mechanical Equipment Maintenance | 15 |
| Adiabatic Pad Maintenance and Replacement | 14 |
| Adiabatic Distribution Basin and Spray Pipe Inspection | 19 |
| Adiabatic Distribution Pipe Cleaning | 20 |
| Adiabatic Pump Screen Cleaning | 21 |
| Adiabatic Recirculation Pump Removal | 22 |
| Adiabatic Y-Strainer Cleaning | 23 |
| Overriding Adiabatic Drain Valve During Power Loss | 24 |
| Maintenance Schedule | 27 |
| Seasonal Shutdown Instructions | 28 |
| Long Term Storage | 28 |
| Troubleshooting | 34 |

Note

The following defined terms are used throughout this manual to bring attention to the presence of hazards of various risk levels, or to important information concerning the life of the product. Also, please observe all Caution and Warning labels on the unit.

Warning

Indicates presence of a hazard which can cause severe personal injury, death or substantial property damage if ignored.

Caution

Indicates presence of a hazard which will or can cause personal injury or property damage if ignored.

Note

Indicates special instructions on installation, operation or maintenance which are important but not related to personal injury hazards.

overview

This User Manual as well as those offered separately on fans, valves, pumps, sensors and the control panel are intended to assure that this OlympusMAX Adiabatic/Dry cooling unit operates properly for the maximum possible time. Since product warrantability may well depend upon your actions, please read this User Manual thoroughly prior to operation.

Note

Use this manual in conjunction with the OlympusMAX Field Wiring Instructions, SPX Cooling Tech document 10000036572.

This User Manual provides information regarding general cooling unit installation and operation. Any deviation from, change or modification to the User Manual, the original design conditions, or the original intended use of the equipment may result in improper installation and/or operation of the unit. Any such deviation, change or modification shall be the responsibility of the party or parties making such deviation, change or modification. SPX Cooling Tech expressly disclaims all liability for any such deviation, change or modification. The equipment shall be warranted in accordance with the applicable SPX Cooling Tech Certification of Limited Warranty.

Note

The maximum installed altitude for this cooling unit is 14,000 ft (4250m) above sea level.

If you have questions about the operation and/or maintenance of this cooling unit, and you don't find the answers in this manual, please contact your sales representative. When writing for information, or when ordering parts, please include the serial number shown on the cooling unit nameplate.

Safety First

The location and orientation of the cooling unit can affect the safety of those responsible for installing, operating, or maintaining the unit. However, since SPX Cooling Tech does not determine the location or orientation of the unit, we cannot be responsible for addressing those safety issues that are affected by the unit's location or orientation.

The following safety issues should be considered by those responsible for designing the unit installation.

- Access to the fans located at the top of the unit
- Access to and from the maintenance access door
- The possible need for portable or fixed ladders to gain access to the fans or the maintenance access door
- The possible need for fall protection
- The possible need for external access platforms



receiving

- Access issues due to obstructions surrounding the unit
- Lockout of mechanical equipment
- The possible need for safety cages around ladders

Note

It is not intended nor assumed that access to the top surface of the unit is needed or necessary for maintenance of the unit.

This is only one of the safety issues that may arise in the design and placement process for the cooling unit. SPX strongly recommends that you consult a safety engineer to be sure that all safety considerations have been addressed.

Unit Location

Space available around the unit should be as generous as possible to promote ease of maintenance and to permit freedom of airflow into and through the unit. Reference general arrangement instructions for guidance on minimum recommendations for clearances. Contact your sales representative for guidance and questions about the adequacy of the available space and the intended configuration of the unit.

Prepare a stable, level support foundation for the unit utilizing the weight, wind, seismic and dimensional information provided in the OlympusMAX™ drawings and instructions. Support must be level per the requirements of the submittal drawings to insure proper operation of the unit.

⚠ Caution

The cooling unit is not intended for operation by persons (including children) with reduced physical, sensory or mental capabilities, or lack of experience and knowledge, unless they have been given supervision or instruction concerning the use of this cooling unit by a person responsible for their safety. Children should be supervised to ensure that they do not play around this cooling unit.

⚠ Warning

The cooling unit must be located at such distance and direction to avoid the possibility of contaminated unit discharge air being drawn into building fresh air intake ducts. The purchaser should obtain the services of a Licensed Professional Engineer or Registered Architect to certify that the location of the unit complies with applicable air pollution, fire, and clean air codes.

⚠ Warning

Adiabatic units should be located away from areas exposed to sparks, welding or other “hot work” due to cellulose pad flammability.

receiving

Receiving and Inspection

Unless otherwise specified, OlympusMAX units ship by truck (or special Marley trailers), which allows the installer to receive, hoist, and install the unit in one continuous operation. Responsibility for the condition of the unit upon its arrival belongs to the trucking company—as does the coordination of multiple shipments, if required.

Prior to unloading the cooling unit from the delivering carrier, inspect the shipment for evidence of damage in transit. If damage is apparent, note the freight bill accordingly. This information will need to be recorded to support any future recovery claim.

Coil Charge

Prior to shipment, the coils are charged with nitrogen gas at the factory to a pressure of 20 psig. This charge verifies that the coil is in good condition and has no leaks. Inspect the pressure gauge shipped on each coil header before the unit is removed from the truck.

Due to temperature changes, the pressure may be above or below the original 20 psig charge pressure. Once the coil pressure has been observed use the following table below to determine your action:

| Coil Pressure Reading | Action |
|--|--|
| 15 psig or greater | Coil good. Unload cooling unit. |
| 0 psig on either coil | Coil has lost pressure. Do not unload the unit. Contact your sales representative to obtain clearance to return the unit to the factory. |
| Pressure between 0 psig and 15 psig on either coil | Contact your sales representative for guidance. |

Locate and remove the literature kit (installation instructions, drawings and bills of material) located in a plastic bag inside the unit. This information should be kept for future reference and maintenance purposes.

Hoisting

Warning

Hoisting instructions must be followed. Failure to follow the hoisting instructions may result in injury or death. For overhead lifts or where additional safety is required, safety slings should also be placed under the cooling unit.

The OlympusMAX module sections have hoisting clips near the top of the modules for overhead lifting and handling. A pair of hoisting clips are located at each endwall of each module and between every fan cell. **All hoisting clips must be utilized during a lift.** Hoisting requirements and weight information can be found in two locations:



receiving

- A decal/label located on the unit endwall access door illustrates spreader bar length requirement, hoisting strap quantity, attachment points, and minimum hoisting strap length.
- An installation drawing with unit weights is provided in the literature kit. Also reference the shipping information to obtain unit weight.
- Review all provided hoisting information prior to hoisting the unit. Remove the OlympusMAX unit from the carrier and hoist into place according to the instructions on the hoisting label and installation drawings.

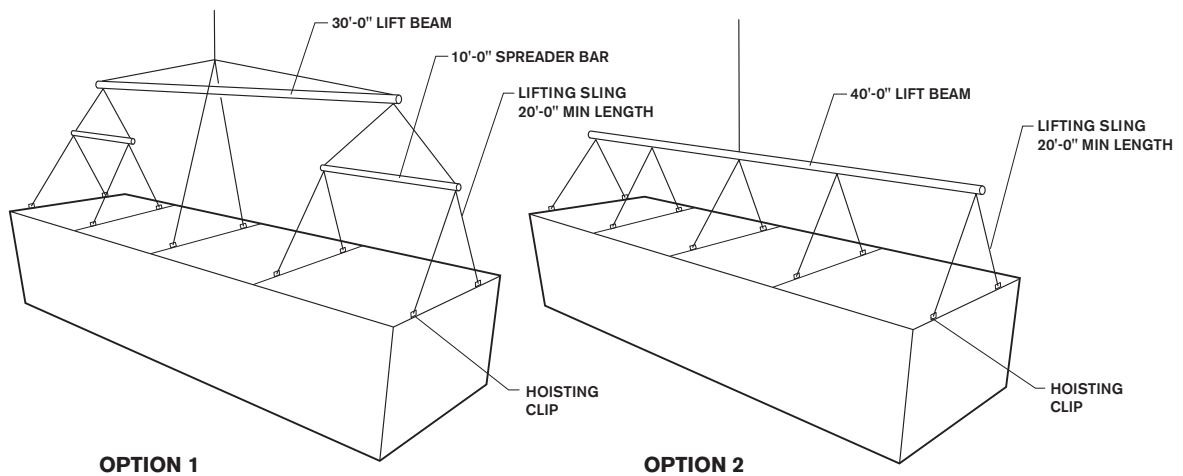

Refer to Hoisting Label on unit
for additional details and instructions

Installation

Note

Installation instructions are intended to help prepare the site before OlympusMAX cooling unit arrives. If discrepancies exist between these instructions and those shipped with the unit, the instructions shipped with the unit will govern.

- 1 Prior to placement of the unit, confirm that the supporting structure is level and that the anchor bolt holes are correctly located in accordance with the *Supporting Steel Detail* drawing instructions.
- 2 Remove steel shipping covers from the adiabatic pad sections. Shipping covers may be removed at any time, but removing the shipping covers prior to placement may be advantageous, particularly for the top module.
- 3 Place the bottom module of the unit on the prepared support structure aligning bolt holes with those in the supporting steel. Verify that the unit module orientation agrees with the intended piping arrangement. Attach

installation

the unit to the supporting structure with user supplied $\frac{3}{4}$ " (M20) diameter bolts and flat washers as per the *Supporting Steel Detail* drawing. Position the flat washers between the bolt head and the unit bottom frame flange.

- 4 Before setting and placing the top unit module on the bottom module, clean any debris from the underside of the top module coil section, skid and beams and the top of the bottom module. Place the top module on the top peripheral bearing surface of bottom module, aligning mating holes as it is set in place. Verify that the module orientation agrees with the intended piping arrangement. Attach with the fasteners provided according to OlympusMax field installation assembly instructions.

Note

Installation steps 5 through 9 are required for Adiabatic units only. Skip to step 10 if installing a Dry unit.

- 5 Connect the 2 $\frac{1}{2}$ " vertical PVC riser pipe on the bottom module to the 2 $\frac{1}{2}$ " vertical PVC riser on the top module using the flexible coupling provided.
- 6 Adiabatic Pump End of Unit—Connect the 4" NPT overflow piping to the drain piping. Reference the provided *Schematic Detail* drawing instructions for location of the connection.
- 7 Adiabatic Pump End of Unit—Connect water supply piping to the 2" NPT makeup solenoid valve. Reference the provided *Schematic Detail* drawing instructions for the location of the connection.
- 8 Adiabatic Pump End of Unit—Connect drain piping to two 2" NPT drain valves. Reference the provided *Schematic Detail* drawing instructions for location of the connections.
- 9 Control Panel End of Unit—Connect pump power wiring (pigtail located in the bottom module) to the control panel. Refer to the provided *CoolBoost Opti AD Adiabatic/Dry Controls* User Manual for OlympusMAX.
- 10 Control Panel End of Unit—Connect control sensor communication cable (pigtail located in the bottom module) to the control panel. Refer to the provided *CoolBoost Opti AD Adiabatic/Dry Controls* User Manual for OlympusMAX.
- 11 Control Panel End of Unit—Wire the control panel for customer power, communication. Refer to the provided *CoolBoost Opti AD Adiabatic/Dry Controls* User Manual for OlympusMAX.
- 12 Coil Connection End of Unit—Connect piping to coil connections. Details vary by configuration.



installation

Coil Connection

- 1 The coil connection supports the installation of a Victaulic coupling with a square groove supplied in the outside wall of the inlet and outlet pipe stubs.
- 2 The coil connection also supports welding supply and discharge piping directly to the coil inlet and outlet. A V-groove is supplied in the outside wall of the inlet and outlet pipe stubs to support direct welding.
- 3 On the outlet nozzle, remove the ball valve and pressure gauge and allow the nitrogen charge gas to discharge. Install the provided threaded 1/4" plug with thread seal provided in the field-fastener kit.

Warning

Adiabatic cellulose pads are flammable. When performing grinding or other "hot work" on adiabatic units steps should be taken to protect the adiabatic pads from accidental ignition from "hot work."

- 4 At the V-groove in each inlet and outlet stub pipe, use a grinding wheel or other cutting device to remove the capped end of the pipe.
- 5 Victaulic Coupling—Install the Victaulic flange using the square groove in the inlet and outlet pipe stubs per the manufacturer's instructions. Connect supply and discharge piping.

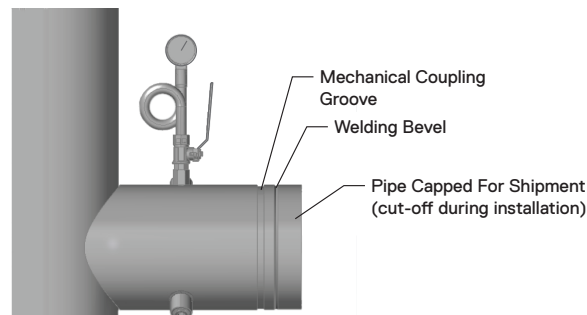

- 6 Direct Weld—Design and size of the weld is the responsibility of others. Prepare the inlet and outlet coil pipe stubs and the customer supply and discharge piping as required and weld the piping directly to the beveled ends of coil stubs.
- 7 Do not support supply and discharge piping loads on the unit. All customer supplied piping must be supported independently.

installation

Mechanical Equipment

⚠ Warning

Always shut off electrical power to the fan motor prior to performing any maintenance. Any electrical switches should be locked out and tagged out to prevent others from turning the power back on.

- 1 Check the Geareducer oil level in accordance with the *Geareducer User Manual*. Although the Geareducer is filled to the proper level at the factory, tipping during shipment and hoisting may have caused some loss of oil. If oil is required, add oil to the proper level with approved lubricant. Refer to the *Geareducer User Manual*.
- 2 Check that the fan guards are installed properly and ensure all fan guard hardware is secure and tightened. Units with Ultra Quiet fans will require field installation of the fan, fan cylinder, and fan guard. Refer to the *OlympusMax Field Installation Guide* for instructions.

⚠ Warning

Improper installation of the fan guard will destroy the structural integrity of the fan guard. Fan guard installation failure could allow operating or maintenance personnel to fall into a rotating fan.

- 3 Spin the fan manually to assure that all fan blades properly clear the inside of the fan cylinder. Observe the action of the coupling to be sure that the motor and Geareducer are properly aligned. If necessary, correct the alignment in accordance with the included User Manuals.

⚠ Caution

*It is essential that the fan guard be installed in accordance with the *OlympusMAX Field Installation Manual* shipped with the unit.*

- 4 Momentarily bump (energize) the fan motor and observe the rotation of the fan. The fan should rotate in a counterclockwise direction when viewed from below. If fan rotation is backwards, shut off the fan motor, lock-out the power supply and reverse two of the three primary fan motor leads at the control panel.
5. Run the motor and observe the operation of the mechanical equipment. Operation should be stable, and there should be no evidence of Geareducer oil leakage.

Note

If the water supply system is not being operated—or if there is no heat load on the system—motor amps read at this time may indicate an apparent overload of as much as 10–20%. This is because of the increased density of unheated air flowing through the fan. Determination of an accurate motor load should await the application of the design heat load.

operation

General Principal of Operation

Dry Cooling

OlympusMAX dry cooling units operate by circulating process fluid through heat transfer coils while ambient air is drawn across the coils removing heat and rejecting it to the atmosphere.

Process fluid outlet temperature is controlled by modulating the fan speed.

Dry units only operate in Stage 1 cooling, defined as fans-only operation.

Adiabatic Cooling

OlympusMAX Adiabatic Series cooling units use water evaporation to depress the dry-bulb temperature of the incoming air to achieve higher cooling capacity than dry air-cooled products. Proper sizing of units is critical to minimize water/energy usage.

The OlympusMAX controls the process fluid outlet temperature/pressure by modulating fan speed and enabling adiabatic operation.

Stage 1 cooling is defined as fans-only operation.

Stage 2 cooling is defined as the addition of recirculating water over the adiabatic pads for dry-bulb suppression. The unit is intended to be run in one of two possible automatic operating modes which prioritize either water or energy savings.

Adiabatic Water System

OlympusMAX controls are configured to periodically drain the water system negating the need for water treatment. The following features have been designed to mitigate the risk of uninhibited biological growth within the adiabatic product:

- Complete drain down of all water distribution piping after each adiabatic cycle
- Complete drying of the precooling media after each adiabatic cycle
- Complete drain down of the sump and piping daily, adjustable for varying site conditions
- Spray-free operation
- Potable supply water

Note

Maintain supply water temperatures at 68°F (20°C) or less to keep Legionella dormant. To minimize the presence of waterborne microorganisms, including Legionella, follow the water management plan for your facility and perform all regularly scheduled inspections and maintenance.

operation

⚠ Warning

Microorganisms including Legionella bacteria can exist in premise plumbing including OlympusMAX cooling unit. The development of an effective water management plan (WMP) and implementation of maintenance procedures are essential to prevent the presence, dissemination and amplification of Legionella bacteria and other waterborne contaminants throughout premise plumbing. Establish and follow an appropriate water management plan and maintenance procedures before operating the adiabatic product.

The nightly drain cycle in the automatic modes for Stage 2 cooling is required and is essential to support a good water management plan.

If the OlympusMAX automatic operating mode controls are not used, it is the operator's responsibility to ensure the adiabatic system is drained at least every 24 hours.

Concentrations of dissolved solids in the recirculating water are managed with an adjustable-setpoint conductivity-based blowdown control. To reduce the risk of scale and corrosion, maintain recirculating water quality parameters within recommended limits.

| Circulating Water Condition Guideline | | | |
|---------------------------------------|--------------------------|-----------|---------------------|
| Constituent | Units | Value | Contributes To |
| pH | | 6.0 - 9.2 | Scale and Corrosion |
| Conductivity | µS/cm | < 3,300 | Scale and Corrosion |
| TDS | ppm | < 2,050 | Scale and Corrosion |
| M-Alkalinity | ppm as CaCO ₃ | 0 - 600 | Scale |
| Calcium Hardness | ppm as CaCO ₃ | 50 - 750 | Scale and Corrosion |
| Chlorides | ppm as Cl | 0 - 300 | Corrosion |
| Sulfates | ppm as SO ₄ | 0 - 250 | Scale |
| Silica | ppm as SiO ₂ | 0 - 150 | Scale |
| Iron | ppm as Fe | 0 - 1 | Scale |
| Manganese | ppm as Mn | 0 - 0.1 | Scale |
| (SiO ₂) x (Mg) | ppm | < 8400 | Scale |
| TSS | ppm | 0 - 25 | Fouling |

For a more detailed description of the control and operation of the Olympus-MAX Adiabatic cooling unit please refer to *CoolBoost Opti AD Adiabatic/Dry Controls* User Manual.

operation

Factors Affecting Operation

The fluid outlet temperature/pressure will vary with the following influences:

- **Heat load:** In Stage 1 and Stage 2 operation, if the heat load increases, the fluid outlet temperature/pressure will also rise.
- **Air dry-bulb temperature:** In Stage 1 and Stage 2 operation, if the ambient dry-bulb temperature increases, the incoming air temperature will be higher resulting in a higher fluid outlet temperature/pressure.
- **Air wet-bulb temperature:** In Stage 2 adiabatic mode, if the ambient wet-bulb temperature increases, the depression of the dry-bulb of the incoming air will be less, resulting in a higher fluid outlet temperature/pressure.
- **Air flow rate:** In Stage 1 and Stage 2 operation, reducing air flow through the unit will result in a higher fluid outlet temperature/pressure.

Freezing Weather Adiabatic Operation

⚠ Caution

The OlympusMAX Adiabatic unit and the recirculating piping should not contain water in the presence of freezing temperatures. Damage to the unit may result if recirculating water is allowed to freeze.

All customer supply and drain lines connected to the OlympusMAX that could contain water in the presence of freezing temperatures should have heat tracing. The design and construction of supply and drain piping is the responsibility of the owner and installing contractor.

The OlympusMAX Adiabatic unit should use only Stage 1 operation during freezing temperatures. The use of Stage 2 operation during freezing temperatures may damage the unit if the recirculating water in the piping, basins and adiabatic pads is allowed to freeze. When the controls system is in automatic operation modes, the system monitors the ambient air temperature and prevents the unit from Stage 2 operation and the use of recirculation water. Manual mode operation of the controls system when freezing temperatures are present may result in damage to the unit.

| Coil Type | Min Fluid Pressure water/brine | Max Fluid Pressure water/brine |
|----------------------------------|-----------------------------------|-----------------------------------|
| Low Pressure Coil—D Shape Header | 0 MPa (0 psig) | 1.72 MPa (250 psig) |

| Coil Fluid Type | Min Fluid Temperature | Max Fluid Temperature |
|----------------------|--|-----------------------|
| Water | 0°C (32°F) | 93.3°C (200°F) |
| Brine/Glycol Mixture | Check specific fluid freezing point | 93.3°C (200°F) |

operation

Coil Freeze Protection

Note

This section applies only to fluid coolers. Not applicable to refrigerant condensers or CO₂ coolers.

Coils are the most expensive components in the unit and must be protected from freezing and bursting. Industry best practice and SPX Cooling recommends using an industrial inhibited glycol process fluid of appropriate concentration to provide freeze protection. The two most common fluids used are Propylene Glycol (PG) and Ethylene Glycol (EG). PG has higher viscosity and thus has a larger efficiency penalty than EG, but PG's lower toxicity makes it preferable for most HVAC applications. Reference the glycol manufacturers' data sheet to determine the appropriate concentration for freeze protection (different than burst protection) at the lowest ambient temperature (including a safety factor) expected at the installation location—typically 20 to 60% concentration. Higher glycol concentrations penalize the heat transfer efficiency and pumping energy more than lower concentrations. Be sure to consider concentration when making cooling unit and process-fluid pump selections. Below are some tips for dealing with glycol solutions:

- Glycol protection is needed in freezing climates from the time the system is filled to the time it is drained and/or retired. Glycol protection is recommended for all systems, including those running continuously, to prevent freezing during any shutdown or idle periods.
- Do not simply displace partial system volume with the required amount of glycol. Proper mixing and circulation is needed to distribute glycol evenly throughout the process fluid. Use quality water and mix according to glycol manufacturer instructions.
- Only use inhibited industrial glycols, do not use automotive or other-grade anti-freeze. Note the minimum concentration for inhibitor effectiveness. Do not mix glycol from multiple manufacturers.
- Check system glycol concentration regularly, especially before cold weather. If an industrial inhibited glycol solution of appropriate concentration is not in place, sufficient flow rate (minimum tube fluid velocity greater than 1 ft/s) and sufficient heat load (minimum coil exit temperature of 45° - 50°F) must be **always maintained during freezing conditions**. This possibly includes weekends, holidays, power outages, planned or unplanned shutdowns, or any other inconvenient time.

Though some operators may choose to drain cooling unit coils as a method to prevent freezing, SPX Cooling does not typically recommend draining as a standard operating procedure for freeze protection due to higher risk of complications. When conducting seasonal or periodic draining, proper system modifications must be in place to ensure quick, complete, and safe draining. Avoid draining (or re-filling) during freezing conditions. Stainless steel and copper coils can typically be drained without accelerating corrosion.

maintenance

Maintenance Procedure

Included with the instruction packet are separate User Manuals for each major operating component of the unit, and it is recommended that you read them thoroughly. Where discrepancies may exist, the separate component user manuals will take precedence.

Interior Inspection

Some maintenance procedures may require maintenance personnel to enter the unit. Before entering the unit, ensure that power to the fans has been turned off and the power supply has been locked out. Failure to lock-out the fan power supply may result in serious injury or death.

Access doors are located on both ends of the unit. Access doors provide access to the unit interior allowing inspection and cleaning of the interior of the unit. Mechanical equipment can be accessed via internal ladder and platform.

⚠ Warning

The purchaser or owner is responsible for providing a safe method for entering or exiting the access door.

⚠ Warning

Coil Inspection and Cleaning

Coils should be inspected periodically to ensure good airflow. The primary concern for coils would be debris clogging the fins on the air intake side of the coils and the development of any corrosion due to environmental conditions.

To inspect the fins on adiabatic units, remove the adiabatic pads as outlined in the **Pad Maintenance and Replacement** section.

⚠ Caution

Aluminum fins are sharp. Injury may result if fins are touched. The aluminum fins are also easily damaged. Avoid touching the fins with your hands or other hard objects.

Once the pads are removed the aluminum fins on the coil should be inspected for debris. The openings between the fins should be open and regular in pattern. To remove debris, use a soft bristle brush with a light action moving with a vertical action parallel to the fins. Scrubbing the fins in a horizontal direction may cause the fins to be damaged.

maintenance

Warning

Before entering the unit, ensure that power to the fans has been turned off and that the power supply has been locked out. Failure to lock out the fan power supply may result in serious injury or death.

Enter through the access door and inspect the interior of the coils and the interior floor. To aid coil cleaning, it is acceptable to gently spray water from the unit interior onto the coil fins to loosen debris on the air inlet surface. Do not use high pressure hose or a pressure washer. Spray water only in the horizontal direction. Failure to do this may result in fin damage.

Damaged fins may be straightened using a fin comb. The coil has a 10 fins per inch (0.1" or 2.5mm fin spacing). Be sure to use a fin comb appropriate for this spacing.

If there appears to be significant scaling on the fins, consult your sales representative for assistance.

Remove any debris from the interior floor of the unit by hand or with a vacuum. Once debris is removed wipe down the floor surfaces.

Mechanical Equipment

Monthly (Weekly at start up) Observe, touch, and listen to the unit. Become accustomed to its normal appearance, sound, and level of vibration. Abnormal aspects relating to the rotating equipment should be considered reason to shut down the unit until the problem can be located and corrected. Observe operation of the motor, coupling, Geareducer and fan. Become familiar with the normal operating temperature of the motor, as well as the sight and sound of all components as a whole.

Check for Geareducer oil leaks.

Semi-Annually

Check the Geareducer oil level. Shut down the unit and allow five minutes for the oil level to stabilize before checking. Add oil if required.

Note

Geareducers are designed for 5-year oil change intervals. To maintain five-year change intervals, use only oil designed specifically for these Geareducers. If, after five years, turbine-type mineral oil is used, the oil must be changed semiannually. Refer to the Geareducer Manual for oil recommendations and further instructions.

Annually: Lubricate motor according to the manufacturer's instructions.



maintenance

Note

If the motor has sealed bearings, additional lubrication is not required. Refer to the motor nameplate to determine if grease type and amount are specified.

Check to see that all bolts are tight in the fan and mechanical equipment region, including the fan cylinder and fan guard. Refer to Component User Manuals for torque values.

Every 5 Years Change Geareducer oil. Refer to the Geareducer User Manual for instructions.

Adiabatic Air Inlet Pad Maintenance and Replacement

Pads can be easily damaged by rough handling.

The water-flow over the adiabatic pads at the unit air-inlet should prevent significant scaling, but debris could still gather on the pads requiring cleaning. With the fans off, a light brushing action may be used to remove leaves, etc. It is also possible to use the control system to reverse the fans to assist in removing debris. If needed, the pads can be removed for cleaning. A light rinse with water can help remove debris. Avoid pressurized streams or jets of water that may damage the pads. Damaged or clogged pads should be replaced. When pads are new, water may bubble and drip from the face of the pads upon initial startup of the circulating water system. After an initial run-in period of wet operation, pads will achieve their normal water control characteristics.

Adiabatic cellulose pads are flammable. When performing grinding or other "hot work" on adiabatic units steps should be taken to protect the adiabatic pads from accidental ignition from "hot work."

⚠ Caution

⚠ Warning

Air Inlet Pad Removal Steps

- 1 Remove upper pad retainer by removing wing-nuts and bolts.



maintenance

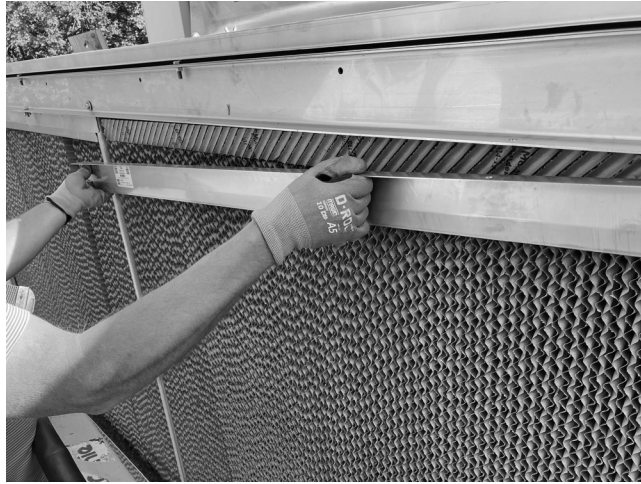

2 Remove upper distribution pad.

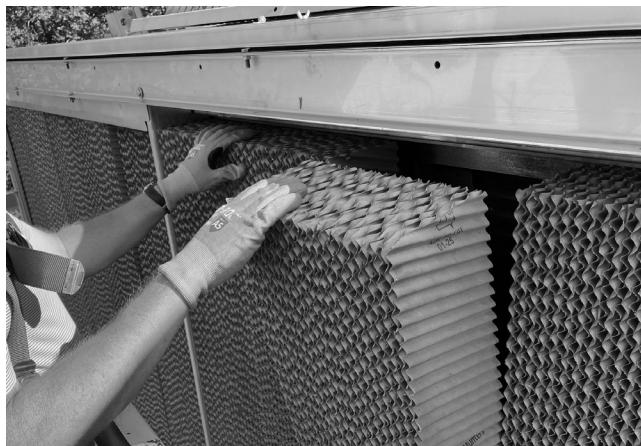
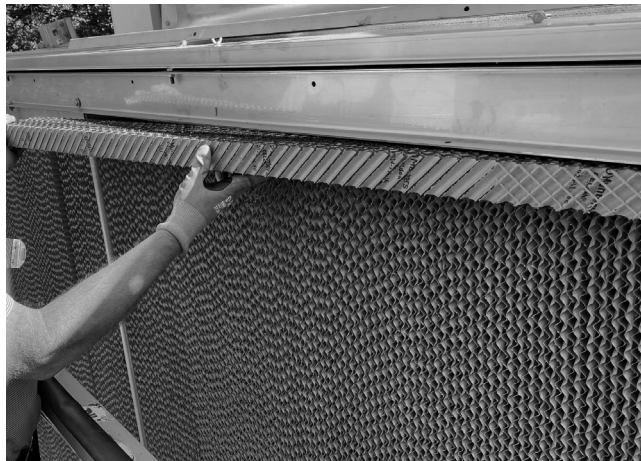

maintenance

- 3 Remove adiabatic pads starting with center pad.

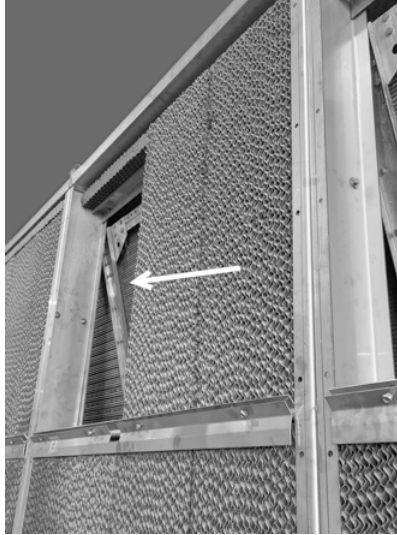

- 4 End pads will need to be shifted inward to clear the end retaining channel.
- 5 Lower pads are retained by a mid-level distribution tray and pad retainer. Remove two wing-nuts and bolts to release the pad retainer.

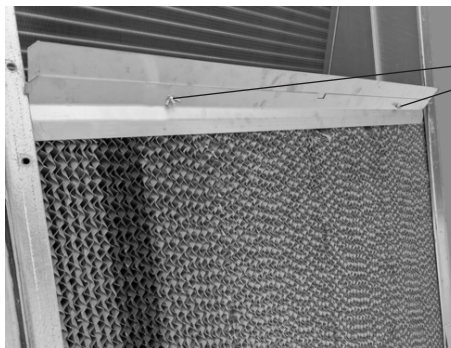

Wing Nuts



maintenance

- 6 Remove the pad retainer. Lower pads can now be removed in a similar fashion as in steps 3 and 4. To reinstall the pads or to install new pads, follow these steps in reverse.



Adiabatic Distribution Basin and Spray Pipe Inspection

Periodically it is necessary to ensure that the distribution pipe is free of debris.

- 1 Open top basin lid by removing wing-nut and bolts.



maintenance

- 2 Open lid to access the distribution basin and piping.



- 3 With the recirculation pipe operating, inspect the eight spray pipe holes to ensure that each hole is free-flowing water onto the sheet metal deflector. Holes are on the underside of the pipe as shown.

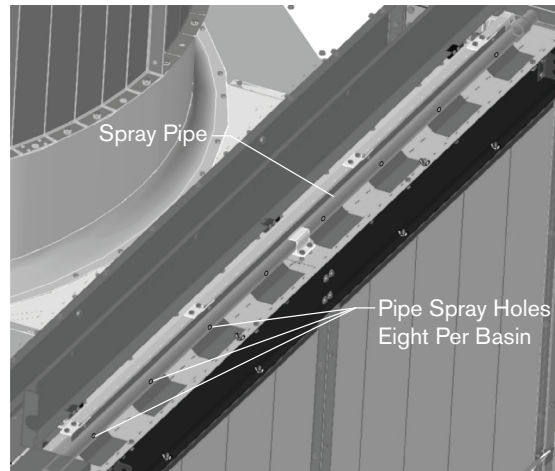

- 4 Also inspect the holes in the basin floor to be sure they are free from debris. Remove the upper pads in order to inspect the holes in the mid-level basin floor. Reinstall the basin covers when inspection is complete.

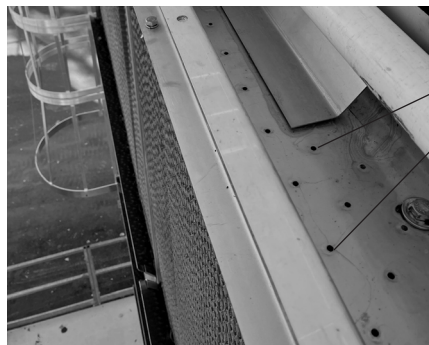

maintenance

Adiabatic Distribution Pipe Cleaning

To flush the distribution piping of any debris, the recirculation pump will need to be engaged to pump water into the distribution piping at the top of the unit and freely discharge water from open pipe ends. If open discharge of water is not permitted, a temporary system to catch and manage the water must be utilized.

- 1 Shut down the recirculation water system and drain the existing recirculating water. Refer to the *CoolBoost Opti AD Adiabatic/Dry Controls User Manual* for instructions.
- 2 Fill the distribution system with fresh water using the start-up procedure. Refer to the *CoolBoost Opti AD Adiabatic/Dry Controls User Manual* for instructions.
- 3 Remove the distribution piping end-caps at the control panel end of the unit.

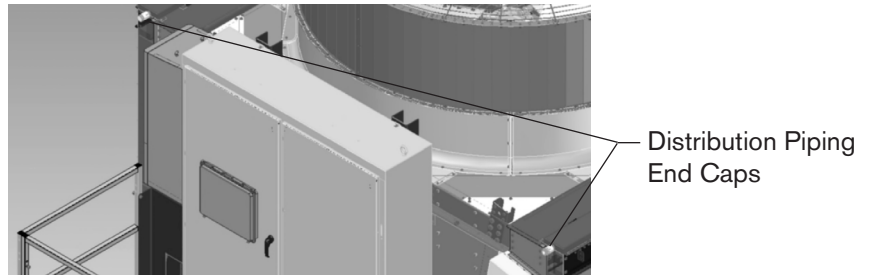

- 4 Start the recirculation pump. Refer to the *CoolBoost Opti AD Adiabatic/Dry Controls User Manual* for instructions. Take care not to run the pump dry as water is expelled from the system.
- 5 After water has been flushed through the pipes, shut down the recirculation pump and inspect the distribution piping and distribution pipe outlet holes to ensure debris has been removed.
- 6 After completion, reinstall piping end-caps.
- 7 If desired, restart the recirculation system according the instructions in the *CoolBoost Opti AD Adiabatic/Dry Controls User Manual*.

Adiabatic Pump Screen Cleaning

Always wear gloves when handling sheet metal. Failure to wear proper protective equipment may result in injury.

The recirculating pump water inlets are provided with screens that must be periodically cleaned. The screens are located within the covered water flume on either side of the pump.

- 1 Shut down the recirculation water system. Refer to the *CoolBoost Opti AD Adiabatic/Dry Controls User Manual* for instructions.



Caution

maintenance

- 2 Remove the water flume covers on either side of the pump by removing wing-nuts securing the cover.

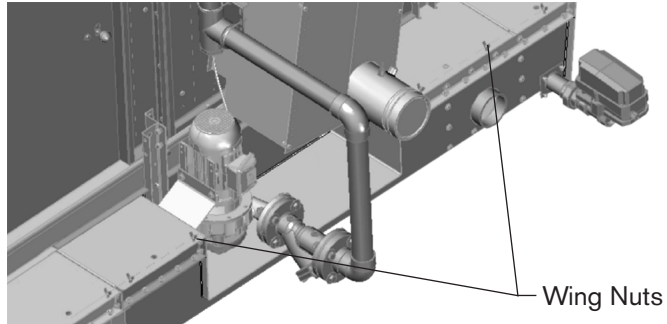

- 3 Once the lid is removed the screen is accessible for cleaning. In most cases the screen will not need to be removed to clean.

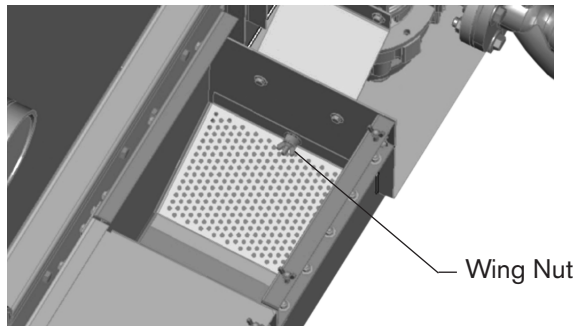

- 4 To remove the screen, remove the wing nut and spacer attaching the screen to the flume.

Adiabatic Recirculation Pump Removal

To access the recirculation pump for cleaning or replacement.

- 1 Shut down and drain the recirculation water system. Refer to the *Cool-Boost Opti AD Adiabatic/Dry Controls* User Manual for instructions.
- 2 If the pump is to be completely removed from the unit, disconnect power to the unit control panel and lock and tag out the power supply. After power has been disconnected to the pump, wiring can be removed from the control panel.

⚠ Warning

Before disconnecting the pump, ensure that power to the control panel has been turned off and that the power supply has been locked out. Failure to lock out the control panel power supply may result in serious injury or death.

maintenance

- 3 Remove the Y-strainer by first removing Y-strainer flange bolts.

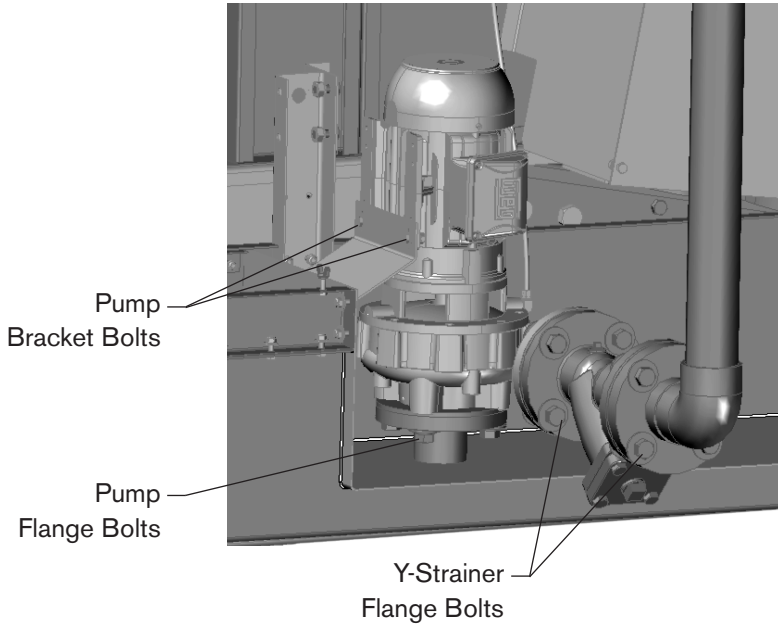

- 4 Loosen and remove the pump bracket bolts.
- 5 Remove the pump flange bolts and remove the pump.

Adiabatic Y-Strainer Cleaning

The Y-strainer must periodically be cleaned.

- 1 Shut down and drain the recirculation water system. Refer to the *Cool-Boost Opti AD Adiabatic/Dry Controls* User Manual for instructions.
- 2 Loosen and remove four flange bolts
- 3 Remove the flange and flange gasket. 

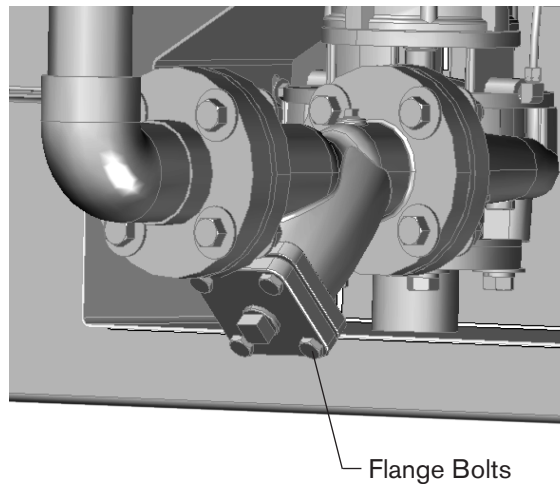

maintenance

- 4 Remove the strainer.
- 5 Clean the strainer using a brush and water.
- 6 Reinstall the strainer making sure it is properly seated.
- 7 Reinstall the flange and flange bolts and tighten in a criss-cross pattern making sure flange seats properly on the strainer and gasket.
- 8 Refill the recirculation system check for leaks.

Overriding Adiabatic Drain Valve During Power Loss

The actuator on the drain valve(s) are fail-in-place. Manually operating the valve may be required if power is lost. Follow these steps to disengage the actuator and manually operate the valve.

- 1 Using a screwdriver or similar device, depress the manual override button on the top of the cover. This disengages the actuator.
- 2 Insert a second screwdriver into one of the holes in the black plastic casting located under the housing, above the valve. **The manual override button must be depressed.** The manual override button can be locked in the depressed position by rotating the screwdriver clockwise.



⚠ Caution

Do not rotate the plastic casting without the manual override button depressed. Damage to the actuator may result.

- 3 Keeping the manual override button depressed, rotate the black plastic casting to the desired position using the screwdriver for leverage.

maintenance

Note

The valve closes with clockwise rotation when viewed from above.



- 4 Verify that the manual override button pops up flush with the top of the cover after work is complete. It may be necessary to rotate the button counterclockwise using the screwdriver to free the button from the locked position.



Manual Override Button
Must be Flush with Top of
Cover

⚠ Caution

Failure to free the manual override button will prevent the actuator and the controls system from operating the valve. Damage to the unit may result.

maintenance

Maintenance Schedule

The maintenance intervals for the components can vary. While the coil may be used throughout the year, it is possible that the adiabatic recirculation system and the air movement mechanical equipment system may only be used during a portion of the year for cooling.

In the Maintenance Service Table the intervals listed should be interpreted as follows:

Monthly—If this component in the table is in regular use, the maintenance service listed should be conducted every month. If the component is not being used for a period longer than 60 days it is not necessary to conduct the monthly maintenance service.

Semi-annual—This maintenance service should be conducted two times per year at approximately six-month intervals.

Annual—If the component listed is in continual use through the year, the maintenance service described should be conducted once per year.

Seasonal Startup—If the component listed is not used for a 60 day or greater period, then the service described should be conducted prior to or during the startup process for the component.

maintenance

| Maintenance Service | Monthly | Semi-annually | Seasonal Startup | Annually |
|---|---------------|---------------|------------------|----------|
| Inspect General Condition and Operation | x | | x | |
| Observe Operation of: | | | | |
| Fans—Inspect wiring connections and observe that fans are in operation when appropriate and is operating in correct direction by observing airflow direction. Fans operate in Stage 1 cooling and Stage 2 cooling. | x | | x | |
| Recirculation Pump—Inspect wiring connections and observe that the pump is in operation when appropriate. Note—the pump only operates for Stage 2 cooling. | x | | x | |
| Water Makeup Valve—Inspect wiring connections and observe that the makeup valve is in operation during Stage 2 cooling. This valve supplies water into the unit and removal of pads is required to inspect operation. | x | | x | |
| Drain Valve—Inspect wiring connections and observe that the drain valves are operating properly during Stage 2 cooling. This valve removes recirculating water from the unit. | x | | x | |
| Inspect for Unusual Noise or Vibration | x | | x | |
| Inspect and Clean: | | | | |
| Air inlet pads | x | | x | |
| Coils | | x | x | |
| Distribution basin, pad support trays and spray pipe | | x | x | |
| Water collection basin | | x | x | |
| Recirculation pump screen and pump exterior | x | | x | |
| Y-strainer | x | | | |
| Fan: | | | | |
| Check and tighten blade and hub fasteners | | R | x | |
| Check fan blade pitch and tip clearance | | | x | |
| Check fan cylinder for loose fasteners | | R | x | |
| Motor: | | | | |
| Lubricate (if required) | | | R | R |
| Check mounting bolts for tightness | | | x | x |
| Operate at least | 3 hours/month | 3 hours/month | 3 hours/month | |
| Gearreducer Drive: | | | | |
| Check for loose fasteners including oil drain plug | | | x | x |
| Check for / repair oil leaks | x | | x | x |
| Check oil level | x | | x | x |
| Make sure vent is open | | x | x | x |
| Check coupling alignment | | | x | x |
| Check for loose coupling fasteners | | | x | x |
| Check coupling bushings for unusual wear | | x | x | x |
| Unit Structure: | | | | |
| Inspect/tighten all fasteners | | x | x | |
| Inspect and touch-up all metal surfaces | | | | x |
| Controls: | | | | |
| Inspect condition of exterior surfaces of the control panel enclosure. Address any deterioration and touch up all metal surfaces | | | | x |
| Inspect wiring connections following all appropriate safety procedures | | | x | x |
| Refer to the CoolBoost <i>OptiAd Adiabatic Controls</i> User Manual (part number 10000027010) for additional control panel maintenance requirements | | | x | x |

R — Refer to Component User Manual

Note: It is recommended at least weekly, that the general operation and condition be observed. Pay attention to any changes in sound or vibration that may signify a need for closer inspection.

maintenance

Seasonal Shutdown

Adiabatic Water System: When the cooling unit is to be shut down for an extended period of time, it is recommended that the cooling unit basin and piping is drained. Drain-line valves should remain open so rainwater or snow melt will drain from the unit. Operating the control system in automatic mode with an ambient adiabatic shutoff temperature setting above 45°F (default controls setting) ensures that the unit is drained for freezing temperatures. It is recommended that users visually verify that the unit is drained at seasonal shutdown.

Coil: See Coil Freeze Protection section.

Adiabatic Air Inlet Pads: Inspect for damage or excessive scaling. Replace pads in poor condition with new pads.

Structure: Inspect metal surfaces for evidence of damage or corrosion. Apply touch-up coating as needed for damaged galvanized coatings. Excessively damaged or corroded parts should be replaced.

Galvanized steel (zinc coating) requires a zinc-rich paint for touch-up. Contact the manufacturer of the coating you intend to use for instructions.

Check structural bolted connections and tighten as required.

Fans: Check fan assembly fastener hardware and tighten as required. Use torque values prescribed in the *Fan User Manual*.

Fan motors: Clean and lubricate motor (if required) at close of each operating season (refer to motor manufacturer's recommendations.) Does not apply to motors with sealed bearings. Check motor anchor bolts and tighten as required.

Prolonged Shutdown: If the shutdown period is longer than seasonal, contact your sales representative for additional information.

Long Term Storage

When placing an OlympusMAX cooling unit into long term storage (generally considered one month or longer) there are some basic but critical maintenance steps required to ensure the unit will be ready to perform as designed when unit operation is needed.

Long term storage guidelines apply not only to units that are stored prior to installation, but to any units that have been installed and operated but taken out of operation and are non-operational for over 30 days.

maintenance

Ground Storage

If the OlympusMAX top and bottom modules are to be stored in a yard at grade prior to installation, steps should be taken to keep the bottom frame of the module units from sinking into soft ground. If sufficient compacted gravel with adequate drainage is not available, the units should be placed on blocking as shown below.

Timber frame size is based on poor soil with limited bearing capacity, smaller timbers may be used for improved soils. Individual blocks in lieu of full length timbers may also be used with improved soil at the discretion of the engineer, but the unit must be supported at the five locations indicated.

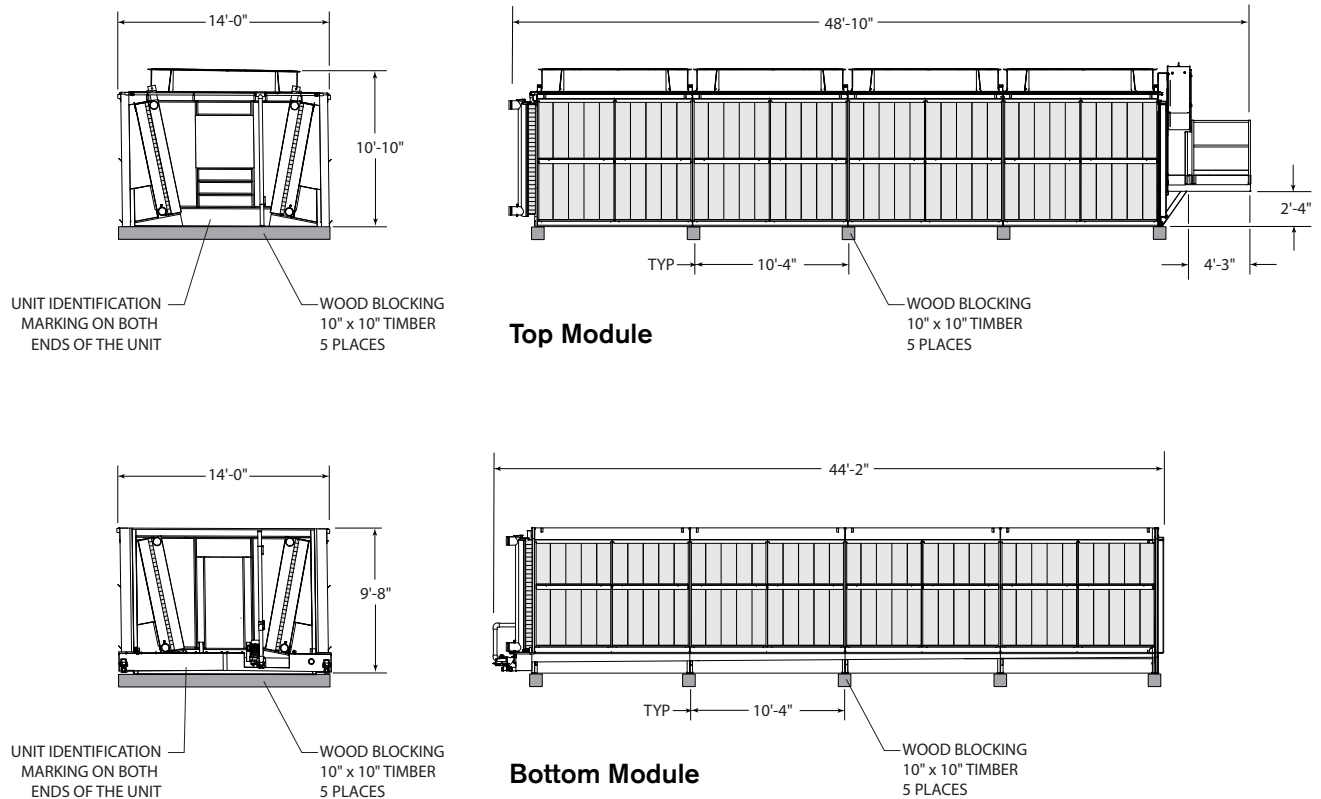

Unit Identification

Top and bottom modules are matched under one unit serial number. For material tracking purposes do not mix top and bottom modules with different identification numbers.



maintenance

Top Module Interior Access

The OlympusMAX top module is not supplied with an access door. For units that have not been stacked and assembled and set on grade, access to the interior will require disassembly of some casing panels on the coil header end of the top module.

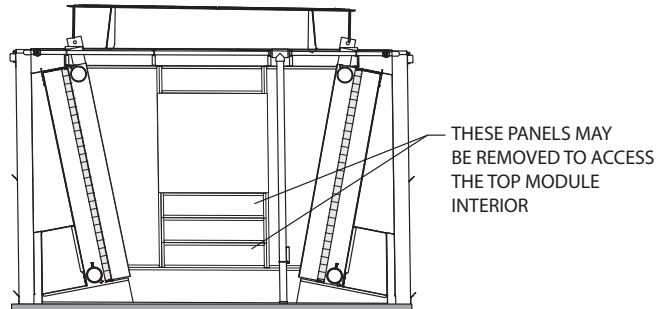

Panels are assembled with sixteen (16) M8 bolts around the perimeter of each panel that will have to be removed. Use 13mm or 1/2" sockets and wrenches for removal. To reinstall, use the turn-of-the-nut method with a 1/4 turn past snug tight. Fasteners may be reused provided they're not damaged.

⚠ Warning

Always shut off electrical power prior to performing any maintenance. Any electrical switches should be locked out and tagged out to prevent others from turning the power back on.

Storage Maintenance—Module Units Not Connected to Power

General Inspection—Top and bottom modules, once per month.

Perform a general inspection for the following items:

- Check for dents or other damage to the sheet metal. Check for damage to other components, including piping and sensors.
- Verify hardware, bolts and screws remain installed and tight.
- Verify no corrosion has developed.
- Verify no Geareducer oil leaks.
- Inspect coil pressure gauge to ensure coils remains pressurized.

Maintenance/Inspection Required—Geareducer, once per month.

Geareducer gears require lubrication every month. To lubricate the gears, enter the interior of the top module as outlined above. Using an appropriate ladder, access the Geareducer and coupling assembly and lubricate the gearbox by rotating the coupling by hand a minimum of ten (10) revolutions. Repeat for all four Geareducer/fan assemblies.

maintenance

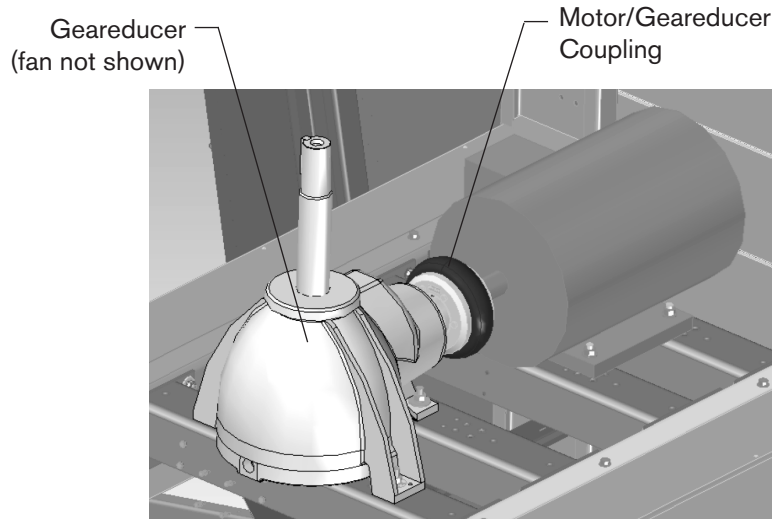

Maintenance/Inspection Required—Pump, once per month.

On the bottom module at the coil header end, remove the pump motor fan cover by removing three screws around the cover perimeter. Once removed the motor and impeller should be manually rotated by turning the exposed fan a minimum of ten (10) revolutions every month. When complete reinstall the fan cover using the turn-of-the-nut method turning $\frac{1}{4}$ turn past snug tight.

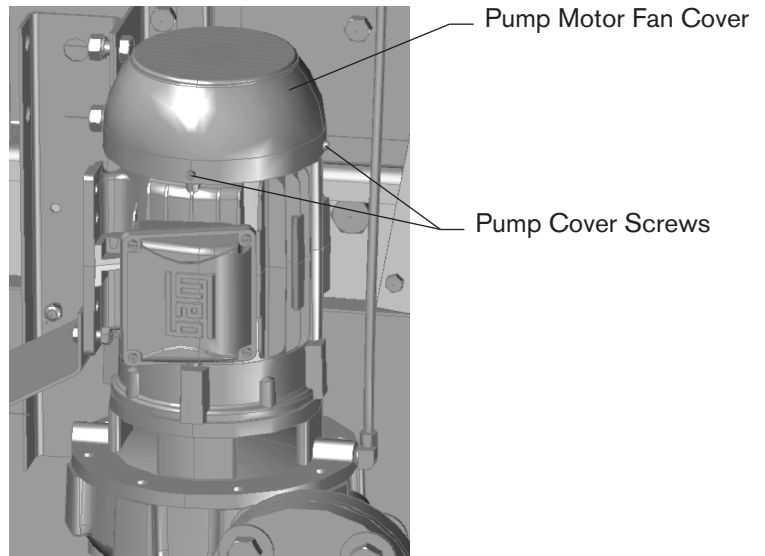

Maintenance/Inspection Required—Interior debris removal, once per month.

Enter the interior of the modules using the bottom module access door or the top module interior using prior access instructions. Remove any debris from the bottom module floor or top module grating panels.



maintenance

Maintenance/Inspection Required—Adiabatic pad inspection, once per month.

On the bottom module inspect the top of adiabatic pad openings along the entire length of the module and remove any debris that has collected in the area above the adiabatic pads.

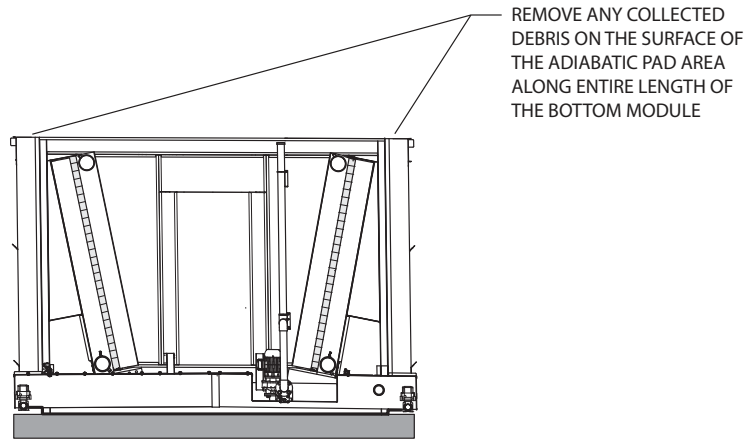

Maintenance/Inspection Required—Drain valves, once per month.

On the bottom module verify that both drain valves are open and free of debris and water is not collecting in the recirculation system.

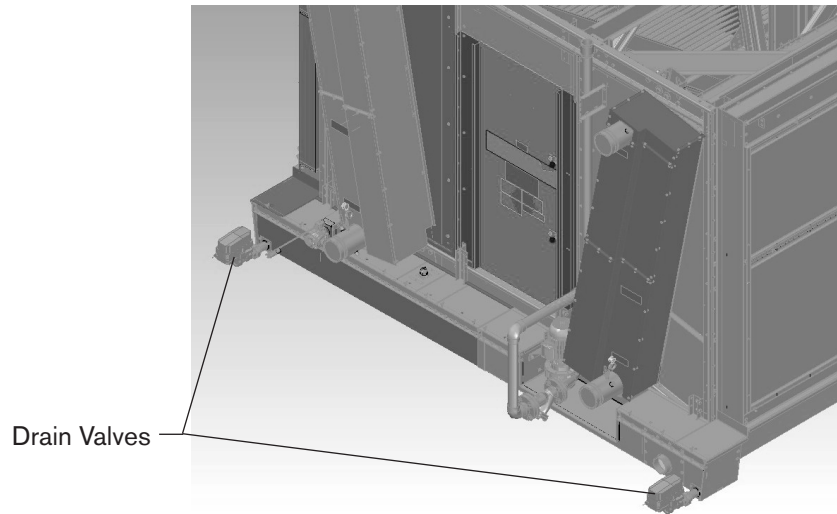

maintenance

Maintenance/Inspection Required—Motor windings.

If storage period exceeds six months, prior to entering or returning to service, perform an insulation test on the motor windings of the fan motors on the top module and the pump motor on the bottom module.

Maintenance/Inspection Required—Control panel condensate drains.

On the top module on the platform end there will be one or two control panels. Every three months check and clean the condensate drains on the control panels if modules are stored in a dusty area. Clean the condensate drain using compressed air to blow out dust or dirt that may have accumulated or clogged any drain openings.

Maintenance/Inspection Required—Control panel air conditioning unit.

Every three months inspect the air conditioner condenser coil. If the condenser coil requires cleaning, use compressed air or a vacuum cleaner with a brush attachment to clean the heat exchanger fins and condenser fan. Do not use water jet or other fluid cleaners. For additional details on servicing the control panel air conditioner please contact your Marley sales representative.

Storage Maintenance—Assembled Units Connected to Power

For units that are assembled and connected to power, but have not been operated for over a month or longer, the following maintenance inspection steps are required:

- Once a month operate the fan motors to ensure the Geareducer gears remains adequately lubricated.
- Once a month inspect the drain valves to verify are they are open and free of debris and water has not collected in the recirculation system.
- Once a month manually turn the pump motor shaft as outlined in the previous section.
- Inspect the control panel drains as outlined in the previous section.
- Inspect the control panel air conditioner as outlined in the previous section.

troubleshooting

| Trouble | Cause | Remedy |
|----------------------|---|---|
| Motor will not start | | Check power at starter. Correct any bad connections between the control apparatus and the motor. |
| | Power not available at motor terminals | Check starter contacts and control circuit. Reset overloads, close contacts, reset tripped switches or replace failed control switches. If power is not on all leads at starter, make sure overload and short circuit devices are in proper condition. |
| | Wrong connections | Check motor and control connections against wiring diagrams. |
| | Low voltage | Check nameplate voltage against power supply. Check voltage at motor terminals. |
| | Open circuit in motor winding | Check stator windings for open circuits. |
| Unusual motor noise | Fan drive stuck | Disconnect motor from load and check motor and Geareducer for cause of problem. |
| | Rotor defective | Look for broken bars or rings. |
| | Motor running single-phase | Stop motor and attempt to start it. Motor will not start if single phased. Check wiring, controls and motor. |
| | Motor leads connected incorrectly | Check motor connections against wiring diagram on motor. |
| | Bad bearings | Check lubrication. Replace bad bearings. |
| | Electrical unbalance | Check voltages and currents of all three lines. Correct if required. |
| | Air gap not uniform | Check and correct bracket fits or bearing. |
| Motor runs hot | Rotor unbalance | Rebalance. |
| | Cooling fan hitting end bell-guard | Reinstall or replace fan |
| | Wrong voltage or unbalanced voltage | Check voltage and current of all three lines against nameplate values. |
| | Overload | Check fan blade pitch. See Fan User Manual. Check for drag in fan drivetrain as from damaged bearings. |
| | Wrong motor RPM | Check nameplate against power supply. Check RPM of motor and gear ratio. |
| | Bearings over greased | Remove grease reliefs. Run motor up to speed to purge excessive grease. Does not apply to motors with sealed bearings. |
| | Wrong lubrication in bearings | Change to proper lubricant. See motor manufacturer's instructions. |
| | One phase open | Stop motor and attempt to start it. Motor will not start if single phased. Check wiring controls and motor |
| | Poor ventilation | Clean motor and check ventilation openings. Allow ample ventilation around motor. |
| | Winding fault | Check with Ohmmeter. |
| | Bent motor shaft | Straighten or replace shaft. |
| Motor runs hot | Insufficient grease | Remove plugs and regrease bearings. Does not apply to motors with sealed bearings. |
| | Too frequent starting or speed changes | Limit cumulative acceleration time to a total of 30 seconds per hour. Set on/off or speed change set-points farther apart. Consider installing a Marley VFD for fine temperature control. |
| | Deterioration of grease or foreign material in grease | Flush bearings and relubricate. Does not apply to motors with sealed bearings. |
| | Bearings damaged | Replace bearings. |

troubleshooting

| Trouble | Cause | Remedy |
|---------------------------------|---|---|
| Motor does not come up to speed | Voltage too low at motor terminals because of line drop | Check transformer and setting of taps. Use higher voltage on transformer terminals or reduce loads. Increase wire size or reduce inertia. |
| | Broken rotor bars | Look for cracks near the rings. A new rotor may be required. Have motor service person check motor. |
| Wrong motor rotation | Wrong sequence of phases | Switch any two of the three motor leads at the control panel. |
| Geareducer noise | Geareducer bearings | If new, see if noise disappears after one week of operation. Drain, flush and refill Geareducer oil. See Geareducer User Manual. If still noisy, replace. |
| | Gears | Correct tooth engagement. Replace badly worn gears. Replace gears with broken or damaged teeth |
| Unusual fan drive vibration | Loose bolts and cap screws | Tighten all bolts and cap screws on all mechanical equipment and supports. |
| | Unbalanced driveshaft or worn couplings | Make sure motor and Geareducer shafts are in proper alignment and "match marks" properly matched. Repair or replace worn couplings. Rebalance driveshaft by adding or removing weights from balancing cap screws. See Driveshaft User Manual. |
| | Fan | Make certain all blades are as far from center of fan as safety devices permit. All blades must be pitched the same. See Fan User Manual. Clean off deposit build-up on blades |
| | Worn Geareducer bearings | Check fan and pinion shaft endplay. Replace bearings as necessary. |
| Fan noise | Unbalanced motor | Disconnect load and operate motor. If motor still vibrates, rebalance motor. |
| | Bent Geareducer shaft | Check fan and pinion shaft with dial indicator. Replace if necessary. |
| | Blade rubbing inside of fan cylinder | Adjust cylinder to provide blade tip clearance. |
| | Loose bolts in blade clamps | Check and tighten if necessary |
| Pump not circulating water | Pump motor not operating | Verify pump has power and is rotating in the right direction |
| | Insufficient starting water | Fill end basin with water to overflow to prime pump. |
| | Vent line clogged | Disconnect copper vent line and clear any obstruction so vent line can purge entrapped air. |
| Poor pad wetting | Y-strain filter is clogged | Remove Y-strain filter, clean and reinstall. |
| | Distribution pipe clogged | Remove distribution pipe threaded end caps and flush pipes with recirculation water. |
| | Distribution pipe holes clogged | Open top basin covers and inspect PVC pipe holes for obstructions. |
| | Holes in top basin clogged | Open top basin covers and inspect basin for debris. Remove filter mat and clean. Clear any obstructed basin holes. |
| | Intermediate pad supporting tray clogged | Remove pads and inspect supporting trays under pads. Clear any obstructed basin holes. |

OlympusMAX

USER MANUAL

SPX COOLING TECH, LLC

7401 WEST 129 STREET
OVERLAND PARK, KS 66213 USA
913 664 7400 | spxcooling@spx.com
spxcooling.com

10000034965 G | ISSUED 5/2026

©2025-2026 SPX COOLING TECH, LLC | ALL RIGHTS RESERVED

In the interest of technological progress, all products are subject to design and/or material change without notice.

