

## Pipe Tap Requirements for Measurement of Water Quantity by Pitot Tube Traverse for Pipes less than 48" Diameter

Each connection or tap consists of a 1" min. diameter pipe coupling, a 1" min. diameter pipe nipple and a 1" min. diameter valve as shown on this sketch. This valve must be fully ported with a minimum opening of 1", In the case of steel pipe, the coupling is welded to the pipe. External fittings should be held to a minimum length. Special instructions are required when taps are to be installed on reinforced concrete or FRP pipe.

These connections should be located on the return pipe to the cooling tower. They may be installed on a horizontal or vertical section of pipe providing an adequate straight run. The most desirable run of pipe for connections should be as long an unobstructed section of straight pipe as is available and easily accessible. The taps should be located at positions a minimum of 8-10 pipe diameters from any upstream interference and 4-5 pipe diameters from any downstream interference. Interference, in this context, refers to valves, elbows, tees, changes in area, etc. The longer the run of straight pipe, the more reliable the results; the critical run of pipe is upstream of the connections.

Due to the difficulty of manipulating the instrument, a large stable working platform such as scaffolding is required if the tap is more than 6 ft. above grade. Ladders are not suitable for working with Pitot tubes.

**NOTE:** As the opening in the pipe and through all fittings must be 1 inch minimum, fittings larger than 1" nominal size may be required. This is frequently the case when it is necessary to hot-tap the hole in the pipe or high pressure valves are utilized.

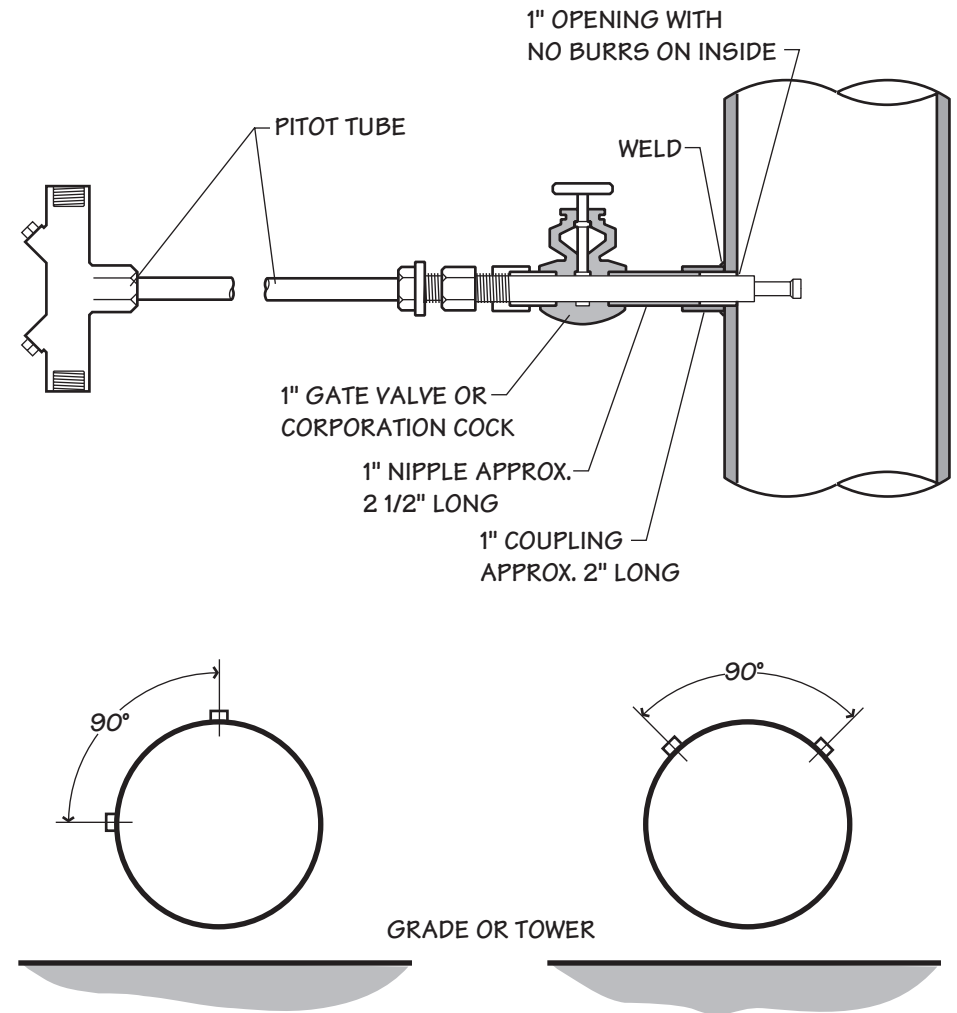

Two connections per pipe are required. These connections are located 90° apart in the same plane. Connections must be located so that ample radial clearance outside the pipe is maintained. A 4 ft. minimum clearance will suffice for smaller pipes up to 24" diameter and 6 ft. minimum clearance for larger pipes.