

# Cooling Tower Fundamentals



# Cooling Tower Fundamentals

Compiled from the knowledge and experience  
of the entire SPX Cooling Technologies staff.

Edited by  
John C. Hensley

SECOND EDITION

Published by  
SPX Cooling Technologies, Inc.  
Overland Park, Kansas USA



Copyright© 2009  
by

**SPX Cooling Technologies, Inc.**  
All Rights Reserved

This book or any part thereof must not be reproduced  
in any form without written permission of the publisher.

Printed in the United States of America

## Foreword

Although the world's total fresh water supply is abundant, some areas have water usage demands that are heavily out of balance with natural replenishment. Conservation and efficient reuse of this precious and versatile resource are mandatory if such areas are to achieve proper development. And, the need for water conservation does not limit itself only to arid regions. Recognition of the detrimental environmental impact of high temperature water discharge into an estuary, whose inhabitants are accustomed to more moderate temperature levels, makes one realize that the re-cooling and reuse of water, however abundant, conserves not just that important natural resource—it conserves nature as well. One helpful means to that end is the water cooling tower.

Those responsible for the specifications, purchasing and operation of plant, station, or building cooling systems must consider many aspects beyond the primary requirement of dissipating unwanted heat. The following text is devoted to identifying the primary and peripheral considerations and offering approaches refined by some eighty years of experience in the cooling tower industry. The goal is to assure the implementation of water cooling systems which will satisfy all design and environmental requirements with sound engineering and responsible cost.

This manual is not intended to be all-encompassing and thoroughly definitive. The entire scope of cooling towers is too broad, and the technology far too advanced, to permit complete coverage in a single publication. Separate brochures by SPX Cooling Technologies, either existing or planned, cover individual topics in depth. The intent herein is to provide a level of basic knowledge which will facilitate dialogue, and understanding, between user and manufacturer.

# Contents

FOREWORD .....	3
<b>SECTION I COOLING TOWER BASICS</b>	
A. Background.....	7
B. Types of Towers.....	8
C. Nomenclature.....	14
D. The Psychrometrics of Evaporation .....	17
E. Factors Affecting Cooling Tower Performance .....	19
F. Materials of Construction .....	29
G. Maintaining Water Quality.....	30
H. Operation in Freezing Weather.....	33
<b>SECTION II STRUCTURAL COMPONENTS</b>	
A. General.....	37
B. Cold Water Basin .....	37
C. Tower Framework.....	41
D. Water Distribution System.....	43
E. Fan Deck.....	47
F. Fan Cylinders .....	47
G. Mechanical Equipment Supports .....	48
H. Fill (heat transfer surface).....	48
I. Drift Eliminators .....	50
J. Casing .....	51
K. Louvers.....	51
L. Access and Safety Considerations .....	52
<b>SECTION III MECHANICAL COMPONENTS</b>	
A. General.....	53
B. Fans.....	53
C. Speed Reducers .....	56
D. Drive Shafts.....	58
E. Valves.....	59
F. Safety Considerations .....	60
<b>SECTION IV ELECTRICAL COMPONENTS</b>	
A. Motors.....	61
B. Motor Controls.....	62
C. Wiring System Design .....	63
D. Cycling of Motors.....	64
<b>SECTION V SPECIALIZED TOWER USAGE AND MODIFICATIONS</b>	
A. General.....	65
B. Water Conservation.....	65
C. Visual Impact and Plume Control .....	68
D. Adiabatic Air Precooling.....	71
E. Energy Reduction .....	72
F. Energy Management and Temperature Control.....	72
G. Noise Control.....	74
H. Drift Reduction.....	76
I. Abnormal Operating Conditions.....	76
J. Vibration Isolation.....	81
K. Free Cooling.....	83
L. Helper Towers.....	86

SECTION VI	AUXILIARY COMPONENTS	
	A. General.....	87
	B. Extended Oil Fill and Gauge Lines.....	87
	C. Mechanical Equipment Removal Devices .....	88
	D. Prevention of Basin Freezing.....	89
	E. Filtering Systems.....	93
	F. Fan Brakes and Backstops.....	94
	G. Air Inlet Screens .....	94
	H. Distribution Basin Covers .....	94
	I. Vibration Limit Switch.....	94
	J. Fire Protection, Prevention and Control.....	95
SECTION VII	THERMAL PERFORMANCE TESTING	
	A. General.....	97
	B. Tower Preparation for Test .....	97
	C. Instrumentation for Test .....	97
	D. Operating Conditions During Test .....	99
	E. Conducting the Test .....	99
	F. Evaluation of Test Data .....	99
SECTION VIII	OWNER RESPONSIBILITIES	
	A. General.....	103
	B. Covering Specification.....	103
	C. Tower Orientation and Site Services.....	104
	D. Economic Evaluation Parameters.....	104
	E. Contractual Information .....	105
	F. Comparing Capability of Proposed Towers .....	106
	G. Cleaning and Biological Control.....	106
SECTION IX	TABLES.....	107
SECTION X	INDEX .....	114

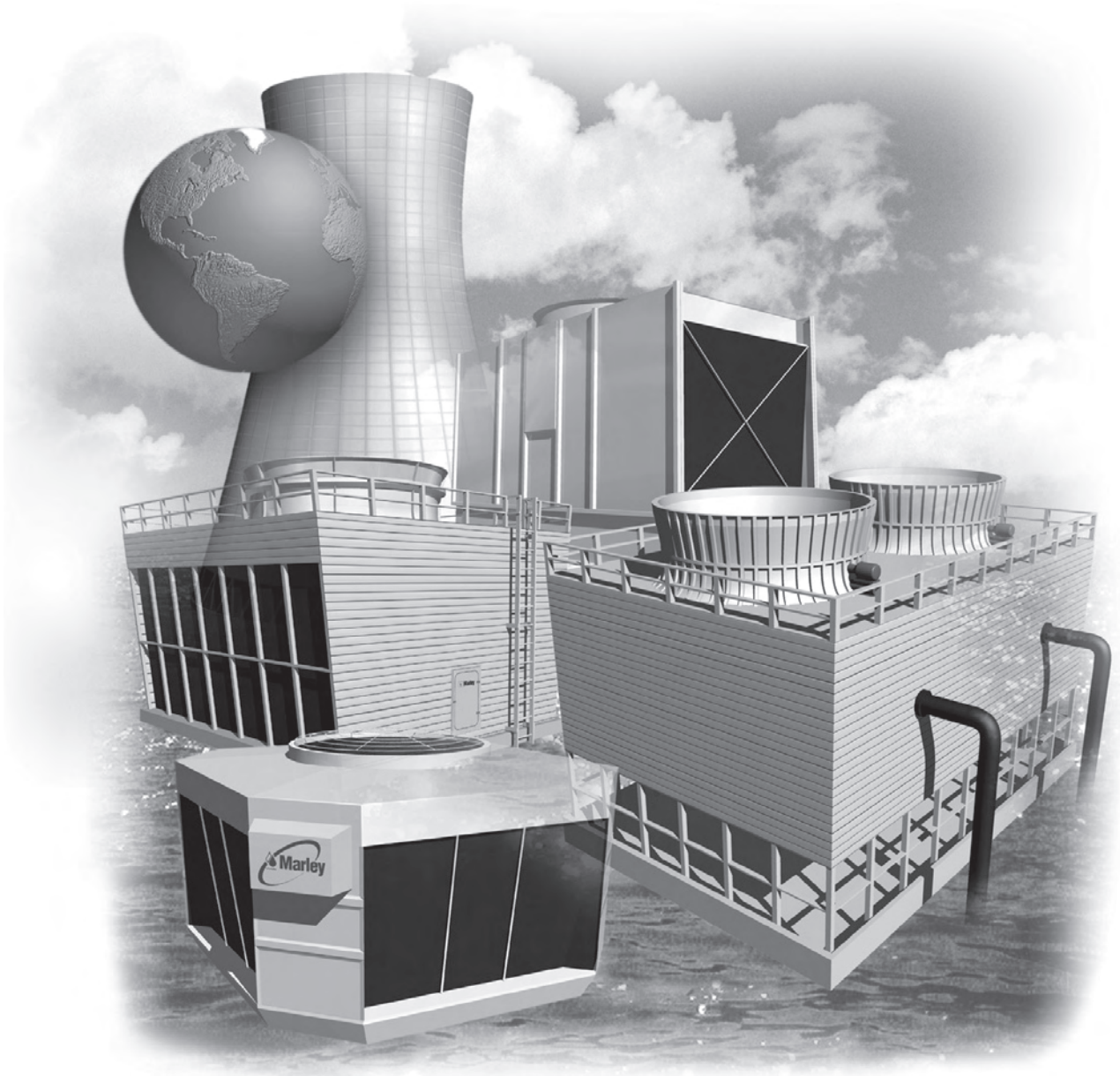

## Cooling Tower Basics

### A. BACKGROUND

The machines and processes of industry, as well as those devoted to human comfort and well-being, generate tremendous amounts of heat which must be continuously dissipated if those machines and processes are to continue to operate efficiently. Although this heat is usually transferred to a cool, flowing volume of water, final rejection is always to the atmosphere and, invariably, is accomplished by some form of heat exchanger. Many of those terminal heat exchangers are not easily recognized as such because they are better known as “creeks”, “rivers”, “lakes”, etc.

The natural process of evaporation makes them very effective heat transfer mediums, although somewhat inefficient due to their limited surface

area and their total dependence upon random winds.

Although the happy man depicted in Figure 1 may not completely understand the principle of evaporation, he is intuitively making use of this most ancient form of natural cooling. Primeval, perspiring mankind depended upon natural breezes to accelerate this evaporation process, and was grateful when they came. At some point in that distant past, however, hands began to manipulate broad leaves to create an artificial breeze – and the basic concept of a cooling tower was unknowingly founded. Eons later, the advanced technology which allows Mr. Figure 1 to revel in a mechanically-produced flow of air made finite development of the cooling tower practicable.

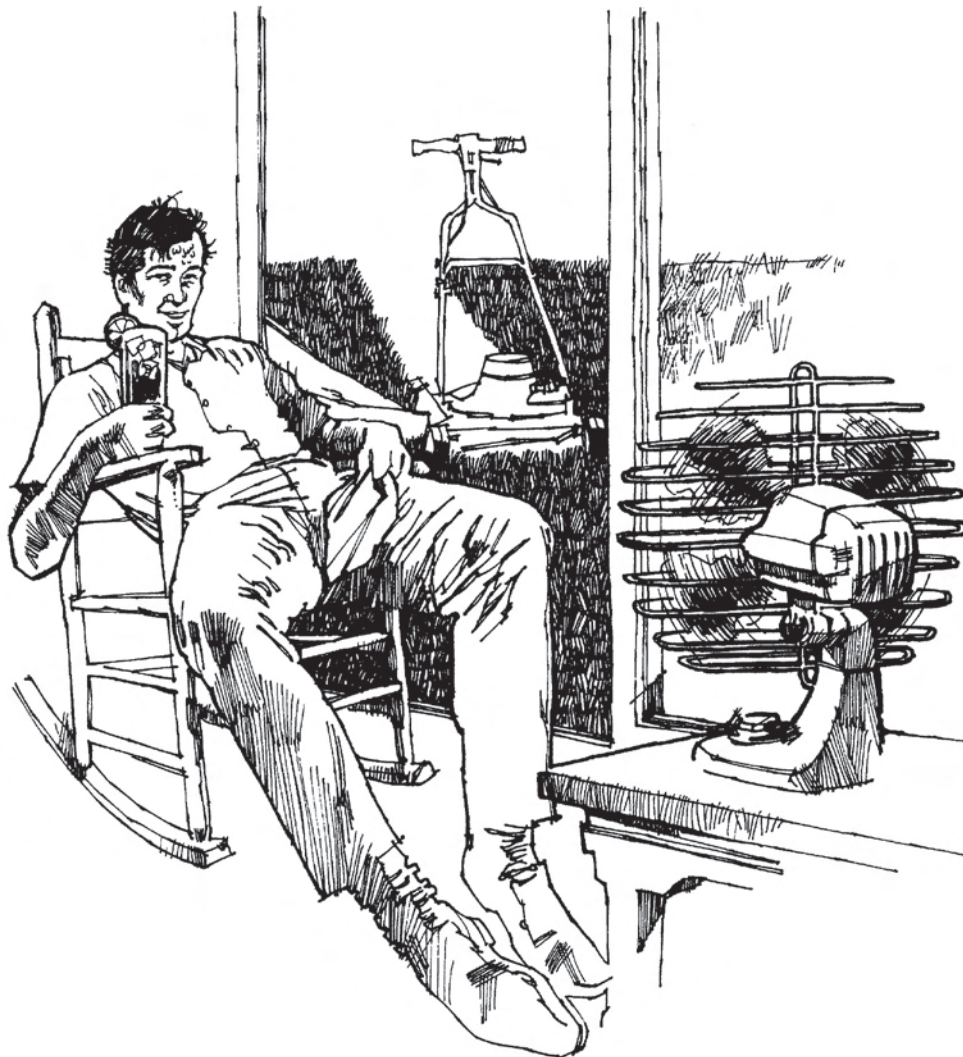

Figure 1 — The principle of cooling by evaporation.



## B. TYPES OF TOWERS

Cooling towers are designed and manufactured in several types, with numerous sizes (models) available in each type. Not all types are suitable for application to every heat load configuration. Understanding the various types, along with their advantages and limitations, can be of vital importance to the prospective user, and is essential to the full understanding of this text.

1. **Atmospheric** towers utilize no mechanical device (fan) to create air flow through the tower. The small atmospheric tower depicted in Figure 2 derives its airflow from the natural induction (aspiration) provided by a pressure-spray type water distribution system. Although relatively inexpensive, they are usually applied only in very small sizes, and are far more affected by adverse wind conditions than are other types. Their use on processes requiring accurate, dependable cold water temperatures is not recommended and as such has become rarely used.

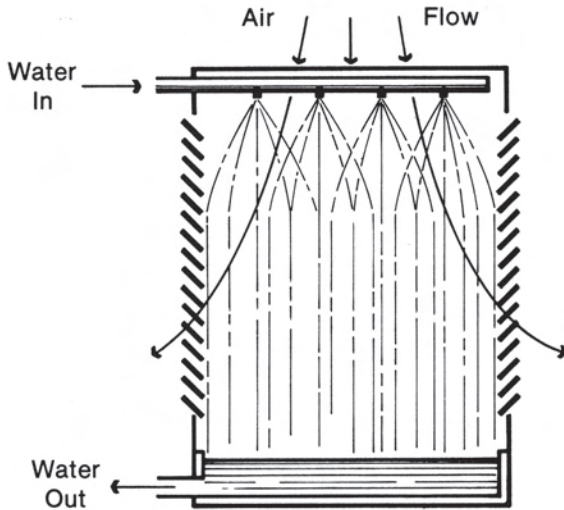

Figure 2 — Atmospheric spray tower.

Conversely, the atmospheric type known as the **hyperbolic natural draft** tower (Figs. 3a & 3b) is extremely dependable and predictable in its thermal performance. Air flow through this tower is produced by the density differential that exists between the heated (less dense) air inside the stack and the relatively cool (more dense) ambient air outside the tower. Typically, these towers tend to be quite large (250,000 gpm and greater), and occasionally in excess of 500 feet in height. Their name, of course, derives from the geometric shape of the shell.

Although hyperbolic towers are more expensive than other normal tower types, they are used extensively in the field of electric power generation, where large unified heat loads exist, and where long amortization periods allow sufficient time for the absence of fan power (and mechanical equipment maintenance costs) to recoup the differential cost of the tower. The synfuels industry also potentially generates heat

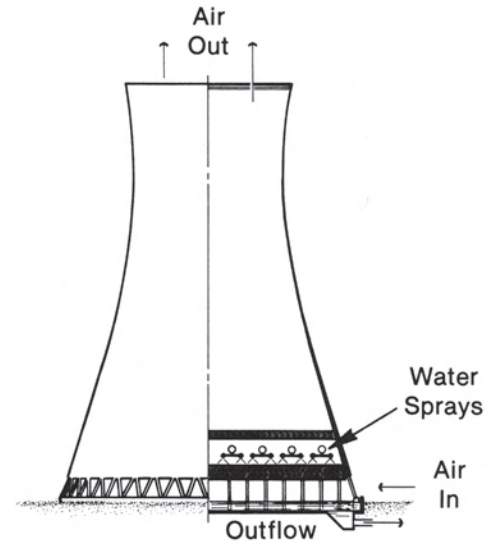

Figure 3a — Counterflow natural draft tower.

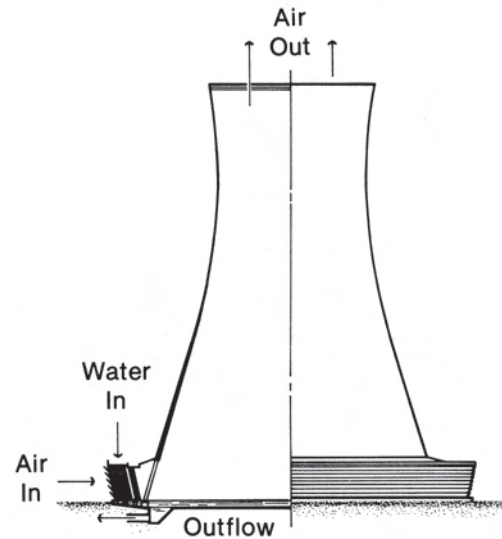

Figure 3b — Crossflow natural draft tower.

loads warranting consideration of the use of hyperbolic towers. However, because natural draft towers operate most effectively in areas of higher relative humidity, many such plants located in arid and/or higher altitude regions find mechanical draft towers more applicable

2. **Mechanical draft** towers use either single or multiple fans to provide flow of a known volume of air through the tower. Thus their thermal performance tends toward greater stability, and is affected by fewer psychrometric variables, than that of the atmospheric towers. The presence of fans also provides a means of regulating air flow, to compensate for changing atmospheric and load conditions, by fan capacity manipulation and/or cycling. (Section V-F)

Mechanical draft towers are categorized as either **forced draft** (Fig. 4), on which the fan is located in the ambient air stream entering the

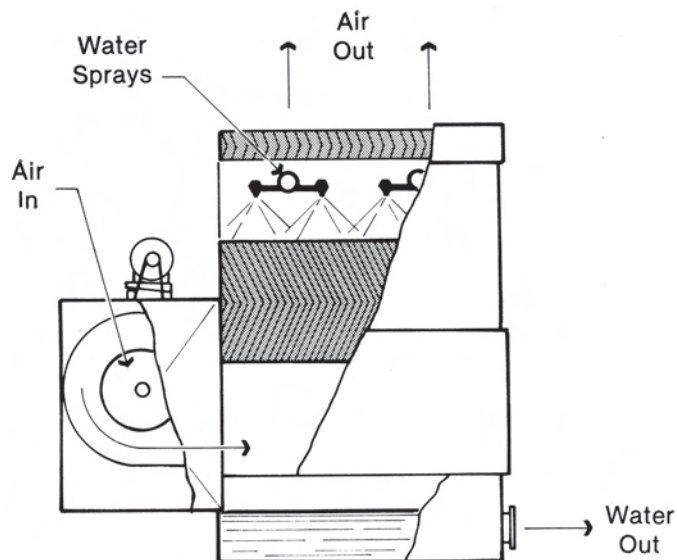

Figure 4 — Forced draft, counterflow, blower fan tower.

tower, and the air is blown through; or **induced draft** (Fig. 5) wherein a fan located in the exiting air stream draws air through the tower.

**Forced draft** towers are characterized by high air entrance velocities and low exit velocities. Accordingly, they are extremely susceptible to recirculation (Sect. I-E-6-(c)) and are therefore

considered to have less performance stability than the induced draft. Furthermore, located in the cold entering ambient air stream, forced draft fans can become subject to severe icing (with resultant imbalance) when moving air laden with either natural or recirculated moisture.

Usually, forced draft towers are equipped with centrifugal blower type fans which, although requiring considerably more horsepower than propeller type fans, have the advantage of being able to operate against the high static pressures associated with ductwork. Therefore, they can either be installed indoors (space permitting), or within a specially designed enclosure that provides significant separation between intake and discharge locations to minimize recirculation.

**Induced draft** towers have an air discharge velocity of from 3 to 4 times higher than their air entrance velocity, with the entrance velocity approximating that of a 5 mph wind. Therefore, there is little or no tendency for a reduced pressure zone to be created at the air inlets by the action of the fan alone. The potential for recirculation on an induced draft tower is not self-initiating and, therefore, can be more easily quantified purely on the basis of ambient wind conditions. Location of the fan within the warm air stream provides excellent protection against the formation of ice on the mechanical components. Widespread acceptance of induced draft towers is evidenced by their existence on installations as small as 15 gpm and as large as 700,000 gpm.

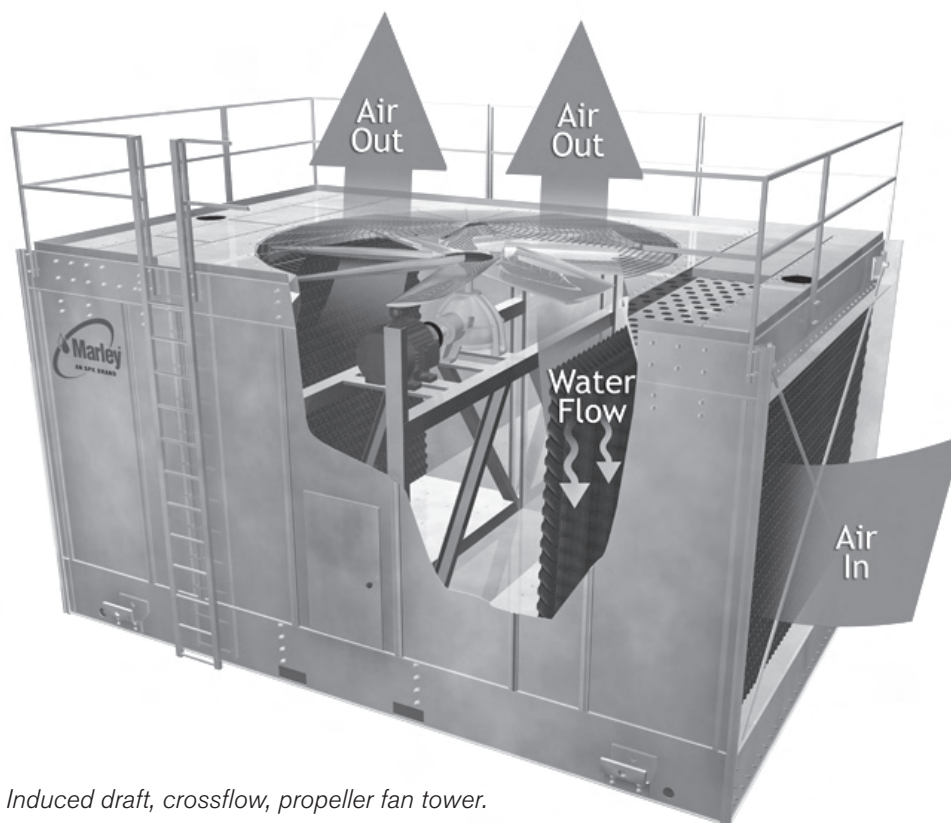

Figure 5 — Induced draft, crossflow, propeller fan tower.



Figure 6 — Fan-assisted natural draft tower.

3. **Hybrid draft** towers (Fig. 6) can give the outward appearance of being natural draft towers with relatively short stacks. Internal inspection, however (Fig. 7), reveals that they are also equipped with mechanical draft fans to augment air flow. Consequently, they are also referred to as **fan-assisted natural draft** towers. The intent of their design is to minimize the horsepower required for air movement, but to do so with the least possible stack cost impact. Properly designed, the fans may need to be operated only during periods of high ambient and peak loads. In localities where a low level discharge of the tower plume may prove to be unacceptable, the elevated discharge of a fan-assisted natural draft tower can become sufficient justification for its use.

#### 4. **Characterization by Air Flow:**

Cooling towers are also “typed” by the relative flow relationship of air and water within the tower, as follows:

In **counterflow** towers (Fig. 8), air moves vertically upward through the fill, counter to the downward fall of water. Because of the need for extended intake and discharge plenums; the use of high-pressure spray systems; and the typically higher air pressure losses, some of the smaller counterflow towers are physically higher; require more pump head; and utilize more fan power than their crossflow counterparts. In larger counterflow towers, however, the use of low-pressure, gravity-related distribution systems, plus the availability of generous intake areas and plenum spaces for air management, is tending to equalize, or even reverse, this situation. The enclosed nature of a counterflow tower also restricts exposure of the water to direct sunlight, thereby retarding the growth of algae. (Sect. I-G-4)

**Crossflow** towers (Fig. 9) have a fill configuration through which the air flows horizontally, across the downward fall of water. Water to be cooled is delivered to hot water inlet basins lo-



Figure 7 — Inside of a fan-assisted natural draft tower.

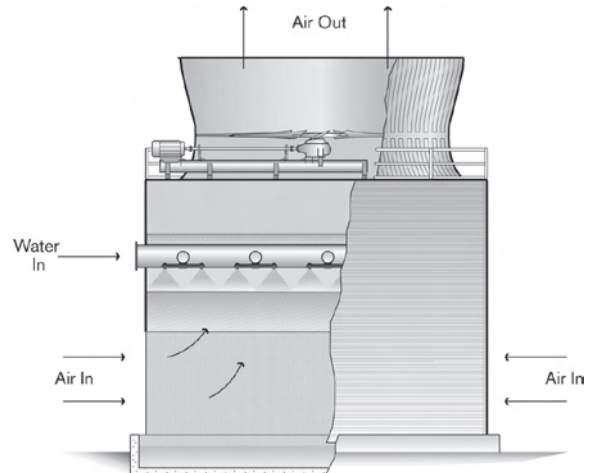

Figure 8 — Induced draft counterflow tower.

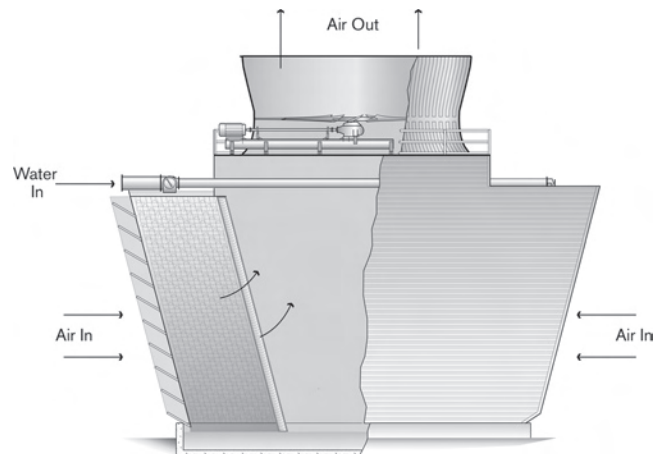

Figure 9 — Induced draft, double-flow, crossflow tower.

cated atop the fill areas, and is distributed to the fill by gravity through metering orifices in the floor of those basins. This obviates the need for a pressure-spray distribution system, and places the resultant gravity system in full view for ease of maintenance. By the proper utilization of flow-control valves (Sect. III-E-2), routine cleaning and maintenance of a crossflow tower's distribution system can be accomplished sectionally, while the tower continues to operate.

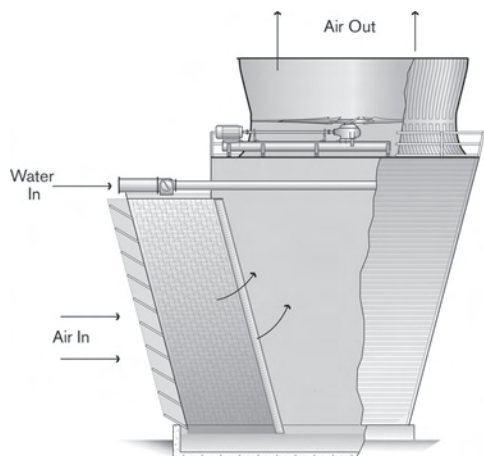

Figure 10 — Induced draft, single-flow, crossflow tower.

Crossflow towers are also sub-classified by the number of fill “banks” and air inlets that are served by each fan. The tower indicated in Figure 9 is a **double-flow** tower because the fan is inducing air through two inlets and across two banks of fill. Figure 10 depicts a **single-flow** tower having only one air inlet and one fill bank, the remaining three sides of the tower being cased. Single-flow towers are customarily used in locations where an unrestricted air path to the tower is available from only one direction. They are also useful in areas having a dependable prevailing wind direction, where consistent process temperatures are critical. The tower can be sited with the air inlet facing the prevailing wind, and any potential for recirculation (Sect. I-E-7-(b)) is negated by the downwind side of the tower being a cased face.

5. **Spray-fill** towers have no heat transfer (fill) surface, depending only upon the water break-up afforded by the distribution system to promote maximum water-to-air contact. The atmospheric tower seen in Figure 2 is a spray-fill tower, as is the tower shown in Figure 16. Removing the fill from the tower in Figure 8 would also make it “spray-fill”. The use of such towers is normally limited to those processes where higher water temperatures are permissible. They are also utilized in those situations where excessive contaminants or solids in the circulating water would jeopardize a normal heat transfer surface. (Sect. V-I-2)

## 6. Characterization by Construction

**Field-erected** towers are those on which the primary construction activity takes place at the site of ultimate use. All large towers, and many of the smaller towers, are prefabricated, piece-marked, and shipped to the site for final assembly. Labor and/or supervision for final assembly is usually provided by the cooling tower manufacturer.

**Factory-assembled** towers undergo virtually complete assembly at their point of manufacture, whereupon they are shipped to the site in as few sections as the mode of transportation will permit. The relatively small tower indicated in Figure 11 would ship essentially intact. Larger, multi-cell towers (Fig 12) are assembled as “cells” or “modules” (see Nomenclature) at the factory, and are shipped with appropriate hardware for ultimate joining by the user. Factory-assembled towers are also known as “packaged” or “unitary” towers.



Figure 11 — Small factory-assembled tower.



Figure 12 — Multi-cell factory-assembled tower.

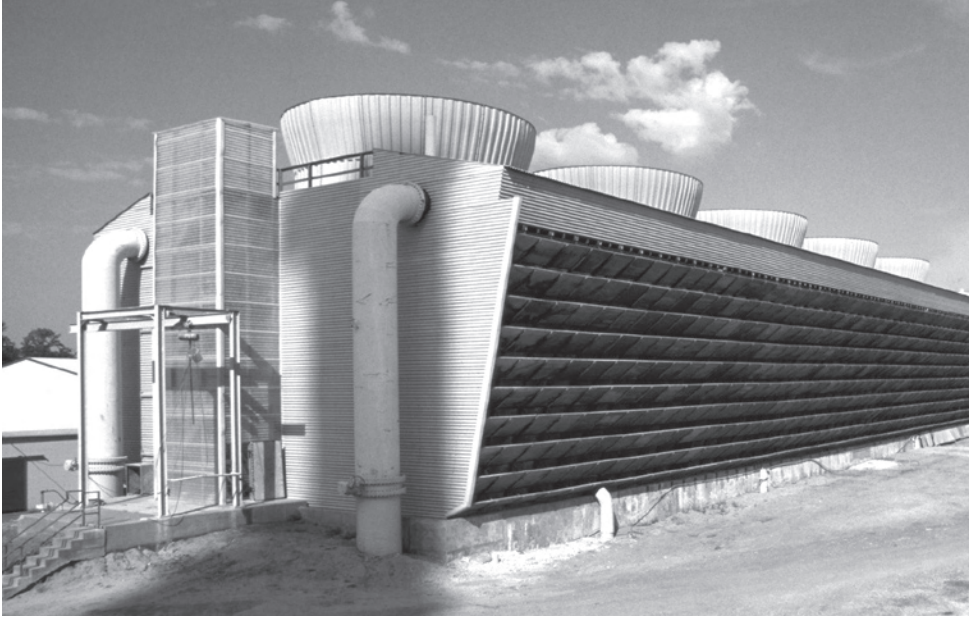

Figure 13 — Multi-cell, field-erected, crossflow cooling tower with enclosed stairway and extended fan deck to enclose piping and hot water basins.

#### 7. Characterization by Shape

**Rectilinear** towers (Fig. 13) are constructed in cellular fashion, increasing linearly to the length and number of cells necessary to accomplish a specified thermal performance.

**Round Mechanical Draft** (“RMD”) towers (Figs. 14 & 32), as the name implies are essentially round in plan configuration, with fans clustered as close as practicable around the centerpoint of the tower. Multi-faceted towers, such as the

Octagonal Mechanical Draft (“OMD”) depicted in Figure 15, also fall into the general classification of “round” towers. Such towers can handle enormous heat loads with considerably less site area impact than that required by multiple rectilinear towers. (Sect. I-E-7-(d), Fig. 39) In addition to which, they are significantly less affected by recirculation. (Sect. I-E-6-(a), Fig. 32)

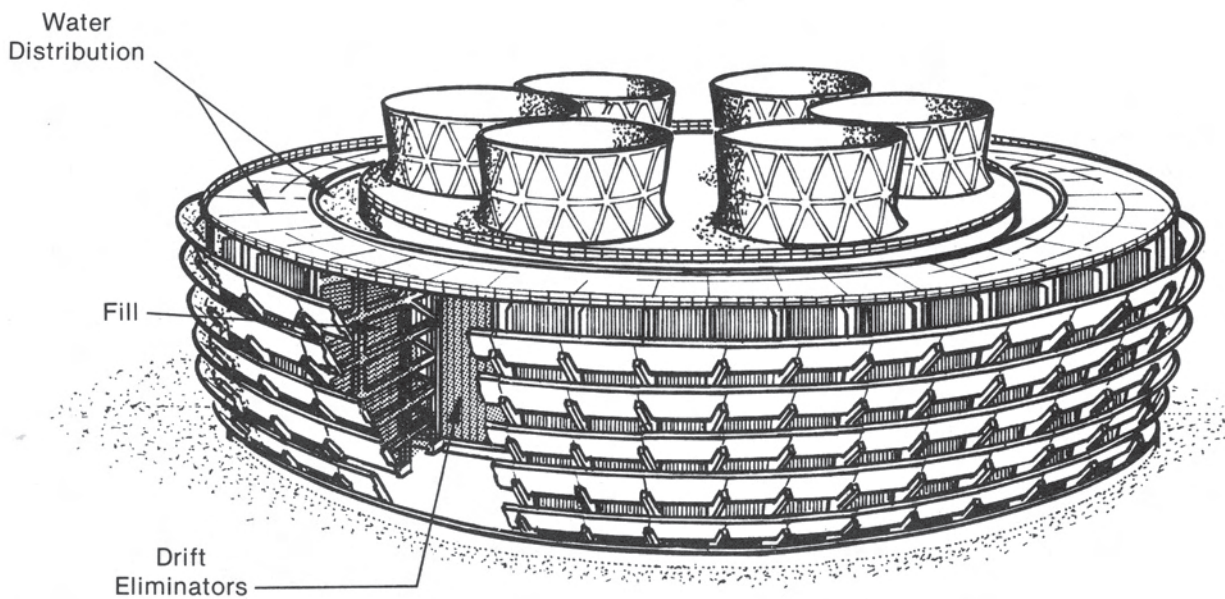

Figure 14 — Round Mechanical Draft (RMD), crossflow cooling tower.

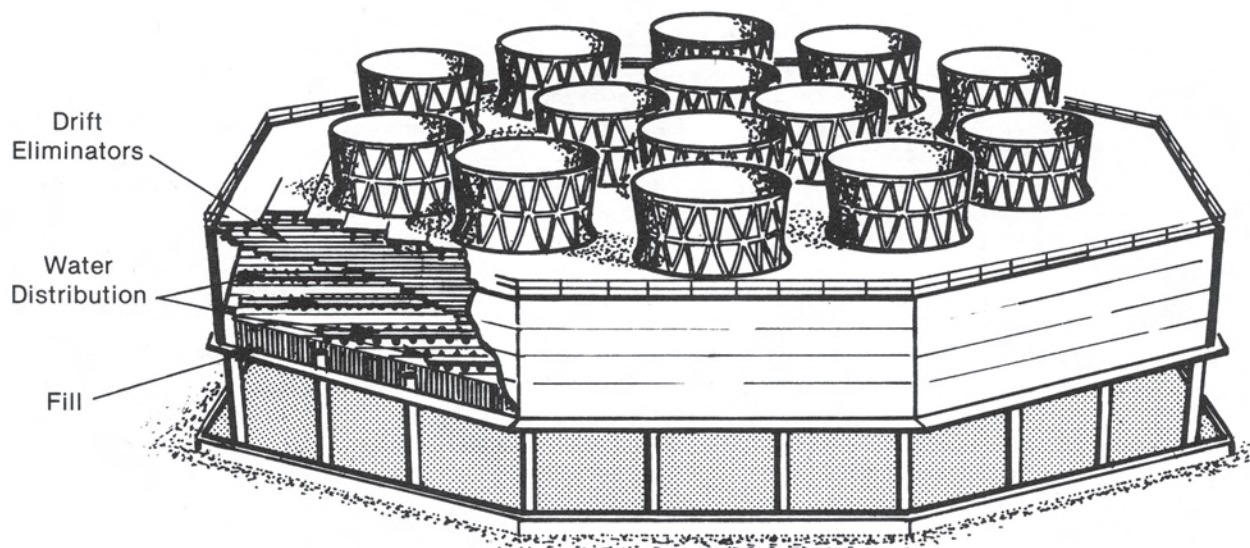

Figure 15 — Octagonal Mechanical Draft, counterflow cooling tower.

#### 8. Characterization by Method of Heat Transfer

All of the cooling towers heretofore described are *evaporative* type towers, in that they derive their primary cooling effect from the evaporation that takes place when air and water are brought into direct contact. At the other end of the spectrum is the *Dry tower* (Sect. V-B, Figs. 98 & 99) where, by full utilization of dry surface coil sections, no direct contact (and no evaporation) occurs between air and water. Hence the water is cooled totally by sensible heat transfer.

In between these extremes are the *Plume Abatement* (Sect. V-C, Fig. 103) and *Water Conservation* (Sect. V-B, Figs 96 & 97) towers, wherein progressively greater portions of dry surface coil sections are introduced into the overall heat transfer system to alleviate specific problems, or to accomplish specific requirements. Dry towers, Plume Abatement, and Water Conservation towers will be discussed in greater depth in Section V of this manual.



**C. NOMENCLATURE**

The following terms are commonly used in cooling tower science, many of which are unique to the cooling tower industry:

**ACFM** – The actual volumetric flow rate of air-vapor mixture. Unit: cu ft per min.

**Air Horsepower** – The power output developed by a fan in moving a given air rate against a given resistance. Unit: hp. Symbol: ahp.

**Air Inlet** – Opening in a cooling tower through which air enters. Sometimes referred to as the louvered face on induced draft towers.

**Air Rate** – Mass flow of dry air per square foot of cross-sectional area in the tower's heat transfer region per hour. Unit: lb per sq ft per hr. Symbol: G'. (See Total Air Rate).

**Air Travel** – Distance which air travels in its passage through the fill. Measured vertically on counterflow towers and horizontally on crossflow towers. Unit: ft.

**Air Velocity** – Velocity of air-vapor mixture through a specific region of the tower (i.e. the fan). Unit: ft per min. Symbol: V.

**Ambient Wet-Bulb Temperature** – The wet-bulb temperature of the air encompassing a cooling tower, not including any temperature contribution by the tower itself. Generally measured upwind of a tower, in a number of locations sufficient to account for all extraneous sources of heat. Unit: °F. Symbol: AWB.

**Approach** – Difference between the cold water temperature and either the ambient or entering wet-bulb temperature. Unit: °F.

**Atmospheric** – Refers to the movement of air through a cooling tower purely by natural means, or by the aspirating effect of water flow.

**Automatic Variable-Pitch Fan** – A propeller type fan whose hub incorporates a mechanism which enables the fan blades to be re-pitched simultaneously and automatically. They are used on cooling towers and air-cooled heat exchangers to trim capacity and/or conserve energy.

**Basin** – See "Collection Basin" and "Distribution Basin"

**Basin Curb** – Top level of the cold water basin retaining wall; usually the datum from which pumping head and various elevations of the tower are measured.

**Bay** – The area between adjacent transverse and longitudinal framing bents.

**Bent** – A transverse or longitudinal line of structural framework composed of columns, girts, ties, and diagonal bracing members.

**Bleed-Off** – See "Blowdown".

**Blowdown** – Water discharged from the system to control concentrations of salts and other impurities in the circulating water. Units: % of circulating water rate or gpm.

**Blower** – A squirrel-cage (centrifugal) type fan; usually applied for operation at higher-than-normal static pressures.

**Blowout** – See "Windage".

**Brake Horsepower** – The actual power output of a motor, turbine, or engine. Unit: hp. Symbol: bhp.

**Btu (British Thermal Unit)** – The amount of heat gain (or loss) required to raise (or lower) the temperature of one pound of water 1°F.

**Capacity** – The amount of water (gpm) that a cooling tower will cool through a specified range, at a specified approach and wet-bulb temperature. Unit: gpm.

**Casing** – Exterior enclosing wall of a tower, exclusive of the louvers.

**Cell** – Smallest tower subdivision which can function as an independent unit with regard to air and water flow; it is bounded by either exterior walls or partition walls. Each cell may have one or more fans and one or more distribution systems.

**Chimney** – See "Shell".

**Circulating Water Rate** – Quantity of hot water entering the cooling tower. Unit: gpm.

**Cold Water Temperature** – Temperature of the water leaving the collection basin, exclusive of any temperature effects incurred by the addition of make-up and/or the removal of blowdown. Unit: °F. Symbol: CW.

**Collection Basin** – Vessel below and integral with the tower where water is transiently collected and directed to the sump or pump suction line.

**Counterflow** – Air flow direction through the fill is counter-current to that of the falling water.

**Crossflow** – Air flow direction through the fill is essentially perpendicular to that of the falling water.

**Distribution Basin** – Shallow pan-type elevated basin used to distribute hot water over the tower fill by means of orifices in the basin floor. Application is normally limited to crossflow towers.

**Distribution System** – Those parts of a tower, beginning with the inlet connection, which distribute the hot circulating water within the tower to the points where it contacts the air for effective cooling. May include headers, laterals, branch arms, nozzles, distribution basins and flow-regulating devices.

**Double-Flow** – A crossflow cooling tower where two opposed fill banks are served by a common air plenum.

**Drift** – Circulating water lost from the tower as liquid droplets entrained in the exhaust air stream. Units: % of circulating water rate or gpm. (For more precise work, an L/G parameter is used, and drift becomes pounds of water per million pounds of exhaust air. Unit: ppm.)

**Drift Eliminators** – An assembly of baffles or labyrinth passages through which the air passes prior to its exit from the tower, for the purpose of removing entrained water droplets from the exhaust air.

**Driver** – Primary drive for the fan drive assembly. Although electric motors predominate, it may also be a gas engine, steam turbine, hydraulic motor or other power source.

**Dry-Bulb Temperature** – The temperature of the entering or ambient air adjacent to the cooling tower as measured with a dry-bulb thermometer. Unit: °F. Symbol: DB.

- Entering Wet-Bulb Temperature – The wet-bulb temperature of the air actually entering the tower, including any effects of recirculation. In testing, the average of multiple readings taken at the air inlets to establish a true entering wet-bulb temperature. Unit: °F. Symbol: EWB.
- Evaluation – A determination of the total cost of owning a cooling tower for a specific period of time. Includes first cost of tower and attendant devices, cost of operation, cost of maintenance and/or repair, cost of land use, cost of financing, etc., all normalized to a specific point in time.
- Evaporation Loss – Water evaporated from the circulating water into the air stream in the cooling process. Units: % of circulating water rate or gpm.
- Exhaust (Exit) Wet-Bulb Temperature – See “Leaving Wet-Bulb Temperature”.
- Fan Cylinder – Cylindrical or venturi-shaped structure in which a propeller fan operates. Sometimes referred to as a fan “stack” on larger towers.
- Fan Deck – Surface enclosing the top structure of an induced draft cooling tower, exclusive of the distribution basins on a crossflow tower.
- Fan Pitch – The angle which the blades of a propeller fan make with the plane of rotation, measured at a prescribed point on each blade. Unit: degrees.
- Fan Scroll – Convolute housing in which a centrifugal (blower) fan operates.
- Fill – That portion of a cooling tower which constitutes its primary heat transfer surface. Sometimes referred to as “packing”.
- Fill Cube – (1) Counterflow: The amount of fill required in a volume one bay long by one bay wide by an air travel high. Unit: cu ft.  
(2) Crossflow: The amount of fill required in a volume one bay long by an air travel wide by one story high. Unit: cu ft.
- Fill Deck – One of a succession of horizontal layers of splash bars utilized in a splash-fill cooling tower. The number of fill decks constituting overall fill height, as well as the number of splash bars incorporated within each fill deck, establishes the effective primary heat transfer surface.
- Fill Sheet – One of a succession of vertically-arranged, closely-spaced panels over which flowing water spreads to offer maximum surface exposure to the air in a film-fill cooling tower. Sheets may be flat, requiring spacers for consistent separation; or they may be formed into corrugated, chevron, and other patterns whose protrusions provide proper spacing, and whose convolutions provide increased heat transfer capability.
- Film-Fill – Descriptive of a cooling tower in which film-type fill is utilized for the primary heat-transfer surface.
- Float Valve – A valve which is mechanically actuated by a float. Utilized on many cooling towers to control make-up water supply.
- Flow-Control Valves – Manually controlled valves which are used to balance flow of incoming water to all sections of the tower.
- Flume – A trough which may be either totally enclosed, or open at the top. Flumes are sometimes used in cooling towers for primary supply of water to various sections of the distribution system. Flumes are also used to conduct water from the cold water basins of multiple towers to a common pumping area or pump pit.
- Fogging – A reference to the visibility and path of the effluent air stream after having exited the cooling tower. If visible and close to the ground, it is referred to as “fog”. If elevated, it is normally called the “plume”.
- Forced Draft – Refers to the movement of air under pressure through a cooling tower. Fans of forced draft towers are located at the air inlets to “force” air through the tower.
- Geareducer<sup>®</sup> – See “Speed Reducer”.
- Heat Load – Total heat to be removed from the circulating water by the cooling tower per unit time. Units: Btu per min. or Btu per hr.
- Height – On cooling towers erected over a concrete basin, height is measured from the elevation of the basin curb. “Nominal” heights are usually measured to the fan deck elevation, not including the height of the fan cylinder. Heights for towers on which a wood, steel, or plastic basin is included within the manufacturer’s scope of supply are generally measured from the lowermost point of the basin, and are usually overall of the tower. Unit: ft.
- Hot Water Temperature – Temperature of circulating water entering the cooling tower’s distribution system. Unit: °F. Symbol: HW.
- Hydrogen Ion Concentration – See “pH”.
- Induced Draft – Refers to the movement of air through a cooling tower by means of an induced partial vacuum. Fans of induced draft towers are located at the air discharges to “draw” air through the tower.
- Inlet Wet-Bulb Temperature – See “Entering Wet-Bulb Temperature”.
- Interference – The thermal contamination of a tower’s inlet air by an external heat source. (i.e. the discharge plume of another cooling tower.)
- Leaving Wet-Bulb Temperature – Wet-bulb temperature of the air discharged from a cooling tower. Unit: °F. Symbol: LWB.
- Length – For crossflow towers, length is always perpendicular to the direction of air flow through the fill (air travel), or from casing to casing. For counterflow towers, length is always parallel to the long dimension of a multi-cell tower, and parallel to the intended direction of cellular extension on single-cell towers. Unit: ft.
- Liquid-to-Gas Ratio – A ratio of the total mass flows of water and dry air in a cooling tower. (See Total Air Rate & Total Water Rate) Unit: lb per lb. Symbol: L/G.
- Longitudinal – Pertaining to occurrences in the direction of tower length.



## SECTION I

- Louvers** – Blade or passage type assemblies installed at the air inlet face of a cooling tower to control water splashout and/or promote uniform air flow through the fill. In the case of film-type crossflow fill, they may be integrally molded to the fill sheets.
- Make-Up** – Water added to the circulating water system to replace water lost by evaporation, drift, windage, blowdown, and leakage. Units: % of circulating water rate or gpm.
- Mechanical Draft** – Refers to the movement of air through a cooling tower by means of a fan or other mechanical device.
- Module** – A preassembled portion or section of a cooling tower cell. On larger factory-assembled towers, two or more shipping modules may require joining to make a cell.
- Natural Draft** – Refers to the movement of air through a cooling tower purely by natural means. Typically, by the driving force of a density differential.
- Net Effective Volume** – That portion of the total structural volume within which the circulating water is in intimate contact with the flowing air. Unit: cu ft.
- Nozzle** – A device used for controlled distribution of water in a cooling tower. Nozzles are designed to deliver water in a spray pattern either by pressure or by gravity flow.
- Packing** – See “Fill”.
- Partition** – An interior wall subdividing the tower into cells or into separate fan plenum chambers. Partitions may also be selectively installed to reduce windage water loss.
- Performance** – See “Capacity”.
- pH** – A scale for expressing acidity or alkalinity of the circulating or make-up water. A pH below 7.0 indicates acidity and above 7.0 indicates alkalinity. A pH of 7.0 indicates neutral water.
- Pitot Tube** – An instrument that operates on the principle of differential pressures. Its primary use on a cooling tower is in the measurement of circulating water flow.
- Plenum Chamber** – The enclosed space between the drift eliminators and the fan in induced draft towers, or the enclosed space between the fan and the fill in forced draft towers.
- Plume** – The effluent mixture of heated air and water vapor (usually visible) discharged from a cooling tower.
- Psychrometer** – An instrument incorporating both a dry-bulb and a wet-bulb thermometer, by which simultaneous dry-bulb and wet-bulb temperature readings can be taken.
- Pump Head** – See “Tower Pumping Head”.
- Range** – Difference between the hot water temperature and the cold water temperature (HW-CW). Unit: °F.
- Recirculation** – Describes a condition in which a portion of the tower’s discharge air re-enters the air inlets along with the fresh air. Its effect is an elevation of the average entering wet-bulb temperature compared to the ambient.
- Riser** – Piping which connects the circulating water supply line, from the level of the base of the tower or the supply header, to the tower’s distribution system.
- Shell** – The chimney-like structure, usually hyperbolic in cross-section, utilized to induce air flow through a natural draft tower. Sometimes referred to as a “stack” or “veil”.
- Speed Reducer** – A mechanical device, incorporated between the driver and the fan of a mechanical draft tower, designed to reduce the speed of the driver to an optimum speed for the fan. The use of geared reduction units predominates in the cooling tower industry, although smaller towers will utilize differential pulleys and V-belts for the transmission of relatively low power.
- Splash Bar** – One of a succession of equally-spaced horizontal bars comprising the splash surface of a fill deck in a splash-filled cooling tower. Splash bars may be flat, or may be formed into a shaped cross-section for improved structural rigidity and/or improved heat transfer capability. When flat, they are sometimes referred to as “slats” or “lath”.
- Splash-Fill** – Descriptive of a cooling tower in which splash type fill is used for the primary heat transfer surface.
- Spray-Fill** – Descriptive of a cooling tower which has no fill, with water-to-air contact depending entirely upon the water break-up and pattern afforded by pressure spray nozzles.
- Stack** – An extended fan cylinder whose primary purpose is to achieve elevation of the discharge plume. Also see “Fan Cylinder” and “Shell”.
- Stack Effect** – Descriptive of the capability of a tower shell or extended fan cylinder to induce air (or aid in its induction) through a cooling tower.
- Standard Air** – Air having a density of 0.075 lb per cu ft. Essentially equivalent to 70°F dry air at 29.92 in Hg barometric pressure.
- Story** – The vertical dimension between successive levels of horizontal framework ties, girts, joists, or beams. Story dimensions vary depending upon the size and strength characteristics of the framework material used. Unit: ft.
- Sump** – A depressed chamber either below or alongside (but contiguous to) the collection basin, into which the water flows to facilitate pump suction. Sumps may also be designed as collection points for silt and sludge to aid in cleaning.
- Total Air Rate** – Total mass flow of dry air per hour through the tower. Unit: lb per hr. Symbol: G.
- Total Water Rate** – Total mass flow of water per hour through the tower. Unit: lb per hr. Symbol: L.
- Tower Pumping Head** – The static lift from the elevation of the basin curb to the centerline elevation of the distribution system inlet; plus the total pressure (converted to ft of water) necessary at that point to effect proper distribution of the water to its point of contact with the air. Unit: ft of water.

Transverse – Pertaining to occurrences in the direction of tower width.

Velocity Recovery Fan Cylinder – A fan cylinder on which the discharge portion is extended in height and outwardly flared. Its effect is to decrease the total head differential across the fan, resulting in either an increase in air rate at constant horsepower, or a decrease in horsepower at constant air rate.

Water Loading – Circulating water rate per horizontal square foot of fill plan area of the cooling tower. Unit: gpm per sq ft.

Water Rate – Mass flow of water per square foot of fill plan area of the cooling tower per hour. Unit: lb per sq ft per hr. Symbol:  $L'$ .

Wet-Bulb Temperature – The temperature of the entering or ambient air adjacent to the cooling tower as measured with a wet-bulb thermometer. Unit: °F. Symbol: WB.

Wet-Bulb Thermometer – A thermometer whose bulb is encased within a wetted wick.

Windage – Water lost from the tower because of the effects of wind. Sometimes called “blowout”.

Wind Load – The load imposed upon a structure by a wind blowing against its surface. Unit: lb per sq ft.

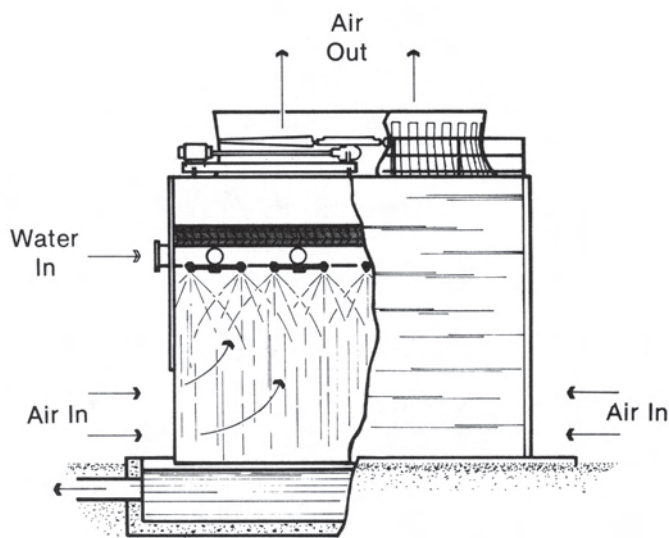

Figure 16 – Spray-fill, counterflow cooling tower.

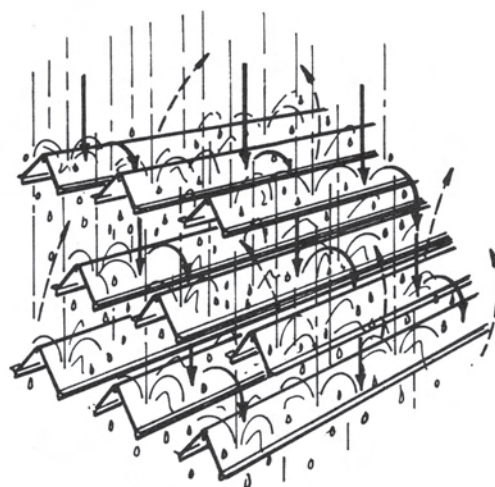

Figure 17 – Typical splash-type fill.

## D. THE PSYCHROMETRICS OF EVAPORATION

Evaporation as a means of cooling water is utilized to its fullest extent in cooling towers, which are designed to expose the maximum transient water surface to the maximum flow of air – for the longest possible period of time.

The spray-fill, counterflow tower shown in Figure 16 attempts to accomplish this basic function by spraying the water into fine droplets, and in containing those droplets to fall through a mechanically-induced, upward-moving stream of air.

It is rather obvious that the overall cooling effect would be improved by increasing the height of the tower, thereby increasing the distance of water fall and maximizing the total time of contact between air and water. In utilizing that method, however, structural and economic limitations would soon be reached.

A significantly better way to increase contact time is by the installation of “fill” within the tower to impede the progress of the falling water. Although the various types of fills, and their configurations, will be discussed in Section II, the basic purpose and action of a splash-type fill is depicted in Figure 17. Placed in the horizontal area of the tower below the sprays – and above the air inlet level, in staggered rows, these splash bars retard the falling water and increase the surface area exposed to the air, thereby promoting the process of evaporation.

*Primary knowledge of how to achieve effective air and water contact notwithstanding, given the problem of cooling water from 85°F to 70°F, how can one hope to do so when the sensible air temperature is 78°F at a 50 percent relative humidity?*

Utilizing only sensible heat transfer (as in an air-cooled heat exchanger) the problem would be

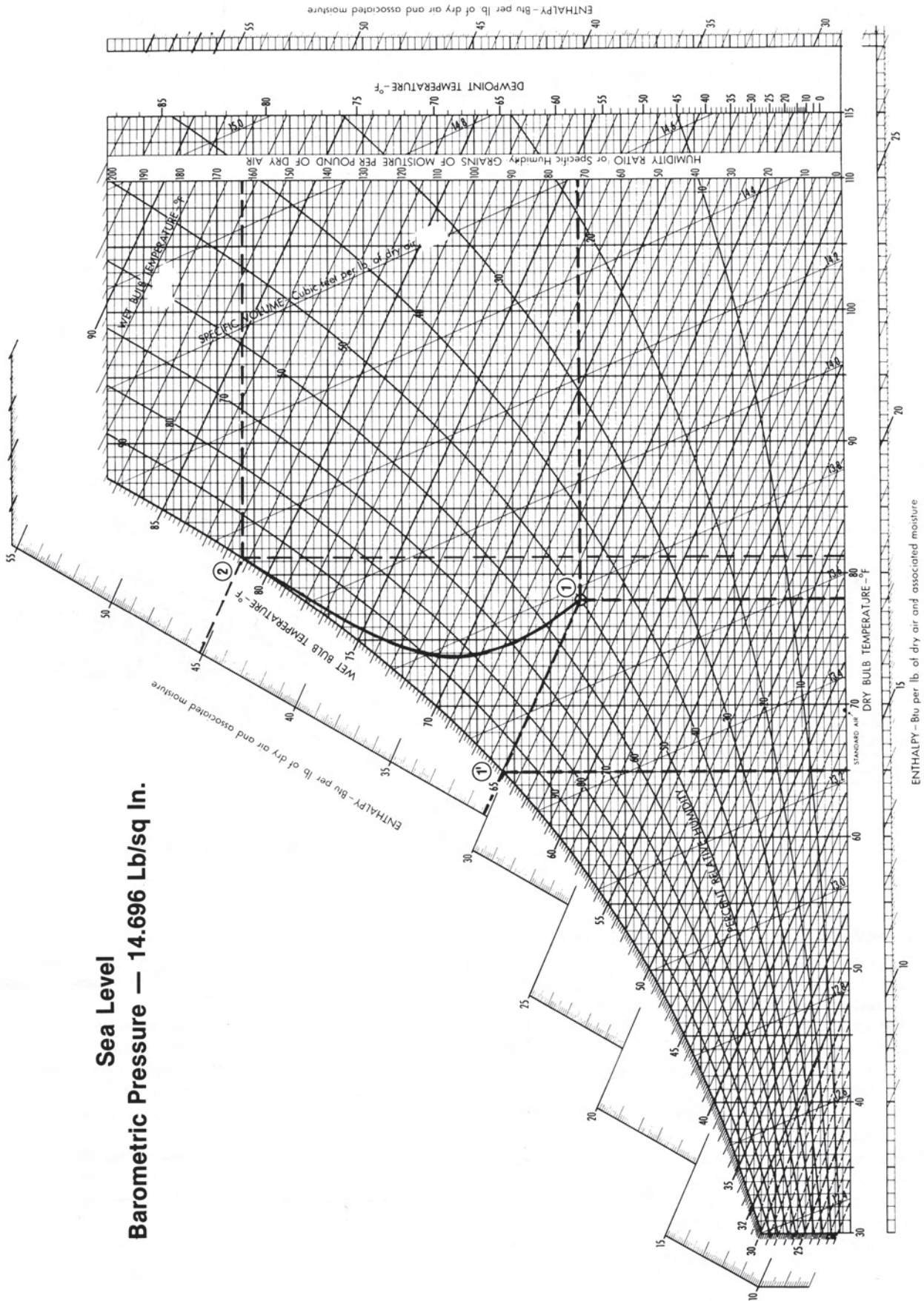

Figure 18 — Psychrometric chart with air-water temperature pursuit curve superimposed.

impossible because the entering air dry-bulb temperature (78°F) is higher than the desired cold water temperature (70°F). However, the process of evaporation that occurs in a cooling tower makes the solution an easy one.

Understanding the evaporative cooling process can be enhanced by tracing on a psychrometric chart (Fig. 18) the change in condition of a pound of air (dry wt.) as it moves through the tower and contacts a pound of water ( $L/G = 1$ ), as denoted by the solid line. Air enters the tower at condition 1 (78°F dry-bulb & 50% R.H.), whereupon it begins to gain moisture content and enthalpy (total heat) in an effort to reach equilibrium with the water, and continues this pursuit of equilibrium until it exits the tower at condition 2.

During the transit of this pound of air through the tower, several notable changes occurred which are pertinent to the study of cooling towers:

1. Total heat content increased from 30.1 Btu to 45.1 Btu. This enthalpy increase of 15 Btu was gained from the water. Since, by definition, a Btu is equal to the heat gain or loss required to change the temperature of one pound of water by 1°F, this means that the temperature of one pound of water was reduced by the specified amount of 15°F (85-70).
2. The moisture content of the pound of air increased from 72 grains to 163 grains. (7000 grains = 1 lb.) This increase of 91 grains (0.013 lbs.) represents total evaporation from the water. Therefore, since the latent heat of vaporization of water (at 85°F) is approximately 1045 Btu/lb, this means that 13.6 (0.013 x 1045) of the 15 Btu removed from the water (91% of the total) happened by virtue of evaporation.
3. Although the temperature of the water was reduced 15°F, the net sensible (dry-bulb) air temperature increase was only 3.3°F, from 78°F to 81.3°F. (Indeed, at a somewhat lower  $L/G$  ratio, the dry-bulb temperature of the leaving air would actually have been *less* than its entering value.)

## E. FACTORS AFFECTING COOLING TOWER PERFORMANCE

The atmosphere from which a cooling tower draws its supply of air incorporates infinitely variable psychrometric properties, and the tower reacts thermally or physically to each of those properties. The tower accelerates that air; passes it through a maze of structure and fill; heats it; expands it; saturates it with moisture; scrubs it; compresses it; and responds to all of the thermal and aerodynamic effects that such treatment can produce. Finally, the cooling tower returns that "used up" stream of air to the nearby atmosphere, with the fervent intention that atmospheric winds will not find a way to reintroduce it back into the tower.

Meanwhile, the water droplets produced by the tower's distribution system are competing with the

air for the same space and, through natural affinity, are attempting to coalesce into a common flowing stream having minimum surface area to expose to the air.

Obviously, the factors which affect cooling tower performance are myriad. Those factors whose effects predominate are identified and discussed in this section. Additional performance-influencing factors will be discussed in succeeding sections.

### 1. *Wet-Bulb Temperature*

Important to note in the foregoing example (Art. D: Fig. 18) is the fact that precisely the same amount of enthalpy exchange (cooling effect) would have taken place had the air entered the tower at a temperature of 65°F and 100% relative humidity (condition 1') which, by definition, is a 65°F "wet-bulb" temperature. For this reason, the primary basis for thermal design of any evaporative type cooling tower is the *wet-bulb temperature* of the air entering the tower.

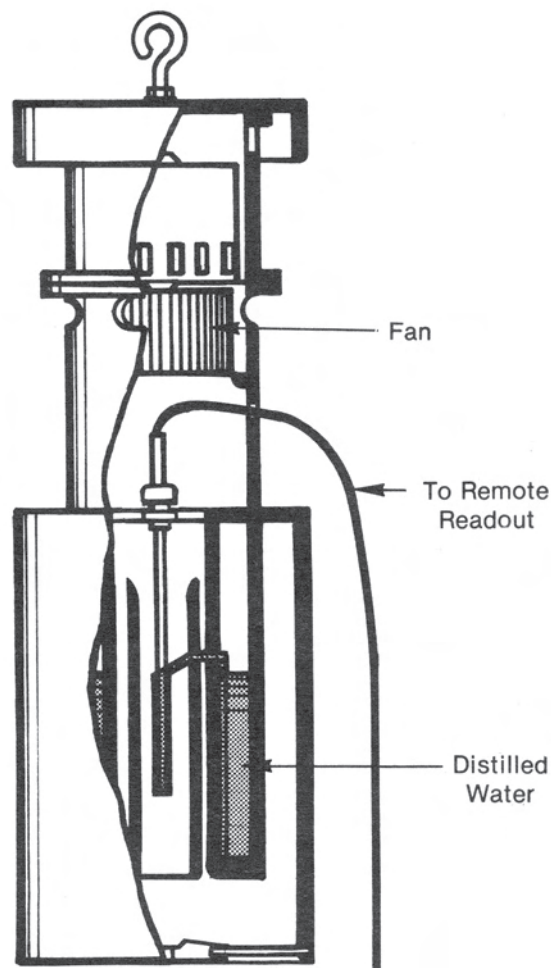

Figure 19 — Mechanically aspirated psychrometer.

In point of fact, design air conditions for the example problem would not have been given to a cooling tower designer as “78°F at a 50% relative humidity”. Rather, instructions would have been to design for a “65°F wet-bulb temperature”. Only if there was a requirement to know the exact amount of evaporation, or if the selection were for something other than a normal mechanical draft cooling tower, would there have been a need to know the design dry-bulb temperature of the air, or its relative humidity.

Wet-bulb temperatures are measured by causing air to move across a thermometer whose bulb (properly shielded) is encased in a wetted muslin “sock”. As the air moves across the wetted bulb, moisture is evaporated and sensible heat is transferred to the wick, cooling the mercury and causing equilibrium to be reached at the wet-bulb temperature. For most acceptable and consistent results, the velocity of the air across the wick must be approximately 1000 fpm, and the water used to wet the wick should be as close as possible to the wet-bulb temperature. Distilled water is normally recommended for wetting of the wick.

When a wet-bulb thermometer and a dry-bulb thermometer are combined in a common device, simultaneous coincident readings can be taken, and the device is called a “psychrometer”.

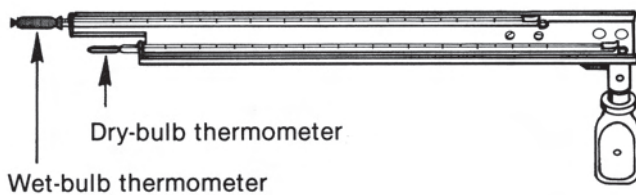

Figure 20 — Sling psychrometer.

Although the mechanically aspirated psychrometer (Fig. 19) is generally used for purposes of testing and scientific study, the sling psychrometer (Fig. 20), used as indicated in Figure 21, can give satisfactory results.

Selection of the design wet-bulb temperature must be made on the basis of conditions existing at the site proposed for a cooling tower, and should be that which will result in the optimum cold water temperature at, or near, the time of peak load demand. Performance analyses have shown that most industrial installations based upon wet-bulb temperatures which are exceeded in no more than 5% of the total hours during a normal summer have given satisfactory results. The hours in which peak wet-bulb temperatures exceed the upper 5% level are seldom consecutive hours, and usually occur in periods of relatively short duration. The “flywheel” effect of the total water system inventory is usually sufficient to carry through the above-average periods without detrimental results.

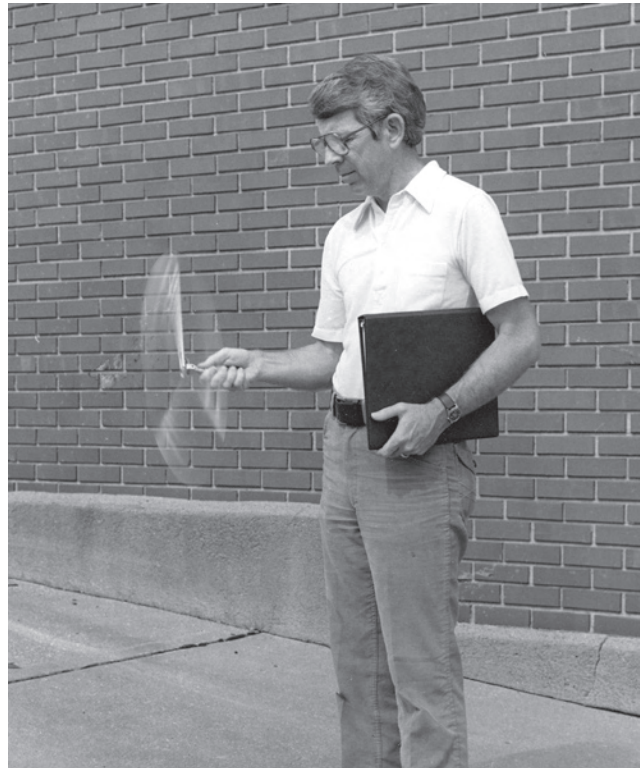

Figure 21 — Sling psychrometer as used to determine wet bulb temperature.

There are some applications, however, where a comprehensive study should be made of the daily (Fig. 22) wet-bulb temperature cycle through critical months and, in some instances, the entire year. (Fig. 23) High-load power generating stations, applications of the cooling tower to off-season free cooling (Sect. V-K), and certain critical processes fall into this category. Wet-bulb duration curves (Fig. 24) may be established from which it is possible to evaluate and compare equipment installed costs, plant operating costs, efficiencies and capabilities at various operating wet-bulb conditions. From such a study, which would consider both seasonal loads and the annual wet-bulb pattern, it is possible to select the optimum cooling tower for the installation. In many cases, the study would result in reduced capital expenditure, while still providing the desired ultimate operating characteristics.

Air temperatures, wet-bulb as well as coincident dry-bulb, are routinely measured and recorded by the United States Weather Bureau, worldwide U.S. military installations, airports, and various other organizations to whom anticipated weather patterns, and specific air conditions, are of vital concern. Compilations of this data exist which are invaluable to both users and designers of cooling towers. One such publication is entitled “Engineering Weather Data”, compiled by the Departments of the Army, Navy and Air Force, and available at [www.wbdg.org](http://www.wbdg.org). Excerpts

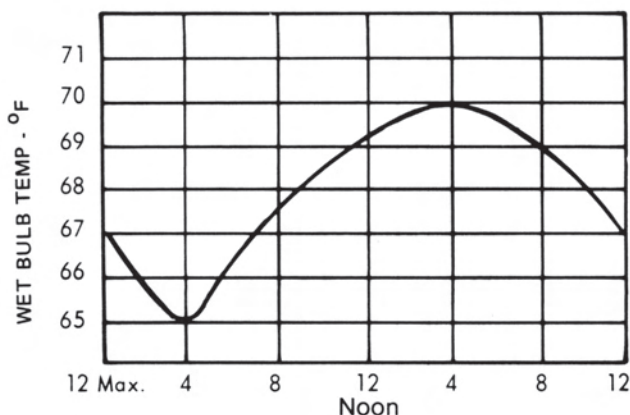

Figure 22 — Daily variation of wet bulb temperature.

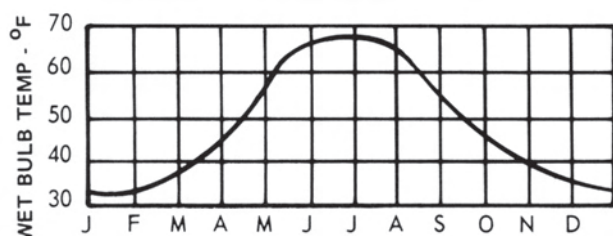

Figure 23 — Annual variation of wet bulb temperature.

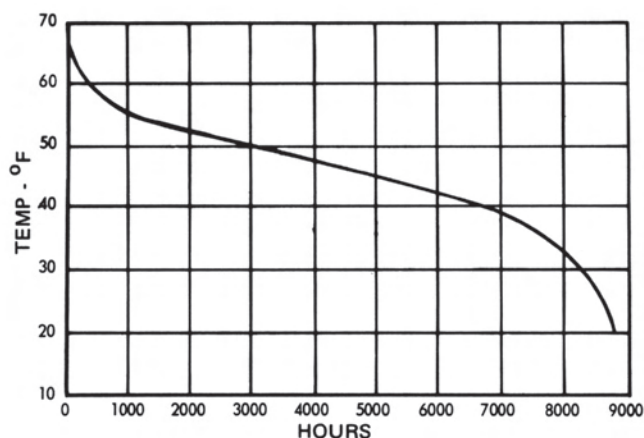

Figure 24 — Typical wet bulb temperature duration curve.

from that and other similar sources, pertinent to the utilization of cooling towers, are also available.

The wet-bulb temperature determined from the aforementioned publications represents the ambient for a geographic area, and does not take into account localized heat sources which may artificially elevate that temperature at a specific site. The codes which govern the sizing and testing of cooling towers define ambient wet-bulb temperature as that which is measured at a distance of 50 to 100 feet upwind of the tower, at an elevation approximately 5 feet above its base, without intervening heat sources. Accordingly,

one can see that an upwind heat source beyond those limitations could cause a cooling tower to experience wet-bulb temperatures somewhat higher than would be anticipated from published data.

Before making a final decision concerning the proper design wet-bulb temperature, it is good practice to take simultaneous wet-bulb readings at the proposed tower site, as well as at other open, unaffected locations at the same plant. These readings should be compared to one recorded at the same time at the nearest source of weather data (airport, weather bureau, etc.), and the apparent design wet-bulb temperature adjusted accordingly.

Finally, and most importantly, once having decided the correct design wet-bulb temperature, the specifier must be clear as to whether the cooling tower manufacturer is to treat it as an **ambient** wet-bulb or an **entering** wet-bulb in the actual design of the tower. As indicated earlier, the basis for thermal design of any evaporative type cooling tower is the wet-bulb temperature of the air actually **entering** the tower. If the design wet-bulb is specified to be **ambient**, then reputable cooling tower manufacturers will adjust that temperature upward, in varying degrees, to compensate for any potential recirculation. (Sect. I-E-6)

Conversely, if the design wet-bulb temperature is specified to be **entering**, then the cooling tower manufacturer will make no adjustment of that temperature in his design, and the wet-bulb temperature at the time of test will be the average of multiple readings taken at the tower air inlets.

Currently, cooling tower test codes provide procedures for measuring performance in the case of either entering or ambient wet-bulb temperature specifications. The **entering wet-bulb** is nearly always used as the specification which produces not only equal competition at the time of bidding, but also provides the least room for doubt at the time that the tower is tested.

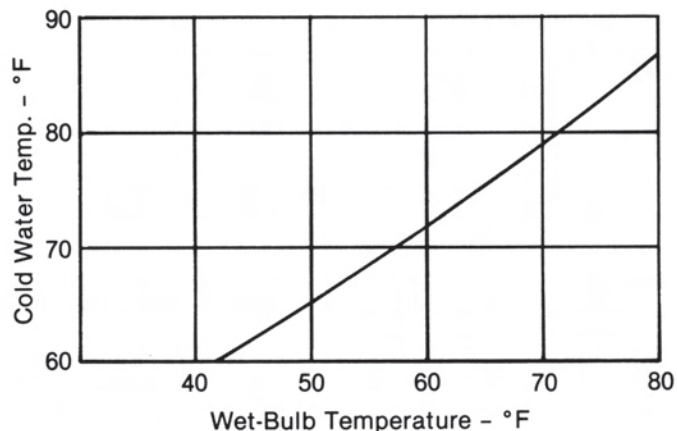

Figure 25 — Typical performance curve.

From the length of this dissertation, one can gather that accurate determination of the design entering wet-bulb temperature is vital, if the cooling tower is to perform as planned. This is supported by Figure 25, which shows the direct relationship between wet-bulb and cold water temperatures. If the actual wet-bulb is higher than anticipated by design, then warmer-than-desired average water temperatures will result. Conversely, if the actual wet-bulb is lower than expected, then the Owner will probably have purchased a cooling tower larger than he needs.

### 2. *Dry-Bulb and/or Relative Humidity*

Although it is always good practice to establish an accurate design dry-bulb temperature (coincident with the design wet-bulb temperature), it is absolutely required only when types of towers are being considered whose thermal performance is affected by that parameter. These would include the hyperbolic natural draft (Fig. 3), the fan assisted natural draft (Figs 6 & 7), the dry tower (Figs. 98 & 99), the plume abatement tower (Fig. 103), and the water conservation tower (Fig. 96). It is also required where there is a need to know the absolute rate of evaporation at design conditions for any type tower. (Fig. 18)

Where required, the same thought process and concern should prevail in the establishment of a design dry-bulb temperature as occurred in determining the design wet-bulb temperature.

### 3. *Heat Load*

Although appropriate selection of the cooling tower size establishes the equilibrium temperatures at which the tower will reject a given heat load, the actual **heat load** itself **is determined by the process being served**. All else being equal, **the size and cost of a cooling tower is proportional to the heat load**. Therefore, it is of primary importance that a reasonably accurate heat load determination be made in all cases. If heat load calculations are low, the cooling tower purchased will probably be too small. If the calculations are high, oversized, more costly equipment will result.

Since volumes of reliable data are readily available, air conditioning and refrigeration heat loads can be determined with considerable accuracy. However, significant variations exist in the realm of industrial process heat loads, each very specific to the process involved. (See Table 1, Section IX) In every case, it is advisable to determine from the manufacturer of each item of equipment involved with, or affected by, the cooling water system the amount of heat that their equipment will contribute to the total.

### 4. *GPM, Range and Approach*

The heat load imposed on a cooling tower (Btu/min.) is determined by the pounds of water per minute being circulated through the process, multiplied by the number of degrees Fahrenheit that the process elevates the circulating water

temperature. In cooling tower parlance, this becomes:

$$\text{Heat Load} = \text{gpm} \times 8.33 \times 60 \times R = \text{Btu/hr (1)}$$

Where: gpm = Circulating water rate in gallons per minute.

8.33 = Pounds per gallon of water at a typical temperature.

R = "Range" = Difference between hot water temperature entering tower and cold water temperature leaving tower, in degrees F.

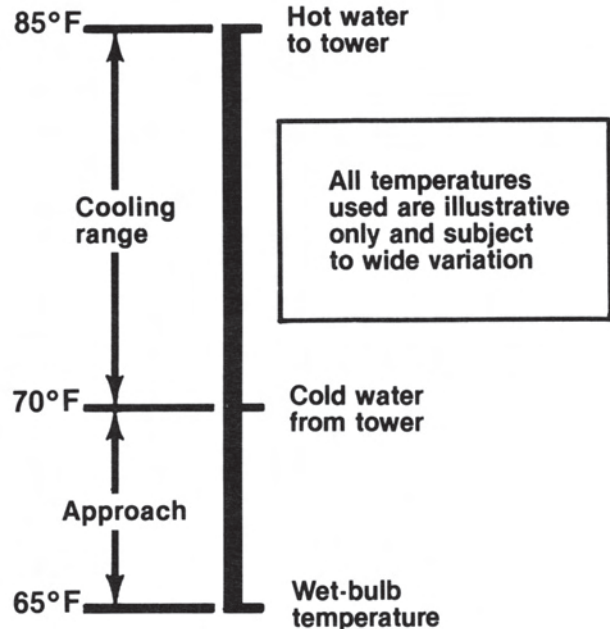

Figure 26 — Diagram showing definition of "Cooling range" and "Approach".

Figure 26 graphically shows the relationship of range and approach as the heat load is applied to the tower. Although the combination of range and gpm is fixed by the heat load in accordance with Formula (1), approach (difference between cold water temperature and entering air wet-bulb temperature) is fixed by the size and efficiency of the cooling tower. A large tower of average efficiency will deliver cold water at a temperature which "approaches" a given wet-bulb temperature no closer than a somewhat smaller tower having significantly better efficiency.

Improving efficiency is, of course, the primary reason for extensive and continuing research and development by cooling tower manufacturers, and subsequent sections of this manual will discuss those factors of design which affect efficiency. Suffice it here to say that increased efficiency will measurably improve (decrease) approach.

Given two towers of reasonably equal efficiencies, operating with proportionate fill configurations and air rates, the larger tower will produce colder water, as evidenced by Figure 27. Important to note, from a tower cost standpoint, is the fact that the "base" tower (15°F approach) would have had to be twice as large to produce a 7°F approach (8°F colder water), whereas it

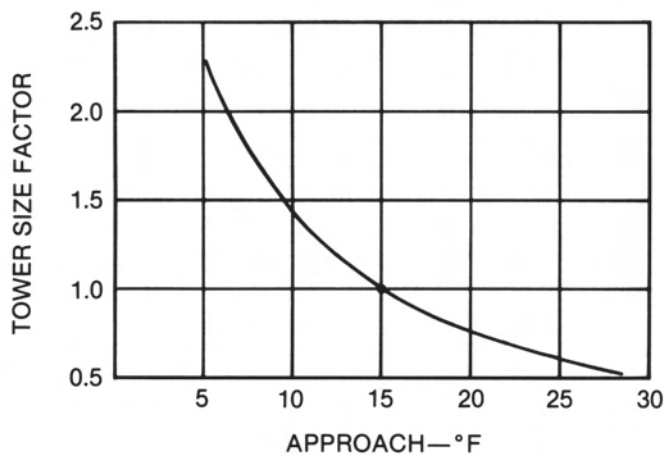

Figure 27 — Effect of chosen approach on tower size at fixed heat load, gpm and wet-bulb temperature.

could have produced a 25°F approach (10°F warmer water) at only 60% of its size.

Note also that the decreasing approach curve is beginning its asymptotic movement toward zero approach. For this reason, **it is not customary in the cooling tower industry to guarantee any approach of less than 5°F** not because towers are unable to produce them but because any errors in measurement become very significant when performance is calculated at the design point.

As can be seen from an analysis of Formula (1), heat load dissipation can be accomplished with almost infinite combinations of flow rates and ranges. Usually, however, a relatively narrow band of possible combinations is dictated by hydraulic limitations and/or temperature-efficient levels of the process being served. Where some latitude of choice is given by the process, a smaller, less costly tower will be required when the range is increased and the GPM decreased, as shown in Figure 28. Although prudent design responsibility places flow and temperature restrictions on cooling towers as well, their latitude usually exceeds that of the typical processes they are designed to serve.

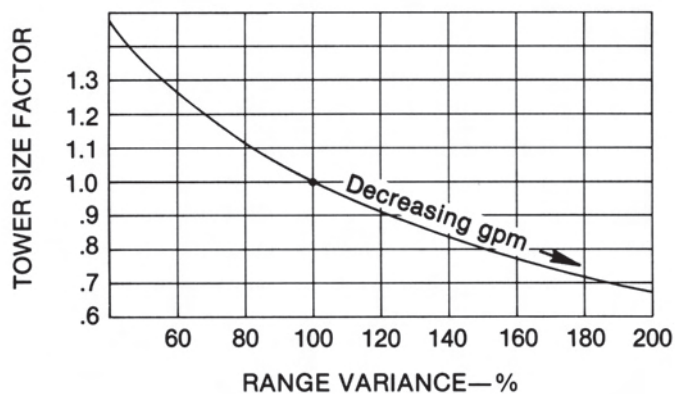

Figure 28 — Effect of varying range on tower size when heat load, wet-bulb temperature and cold water temperature are constant.

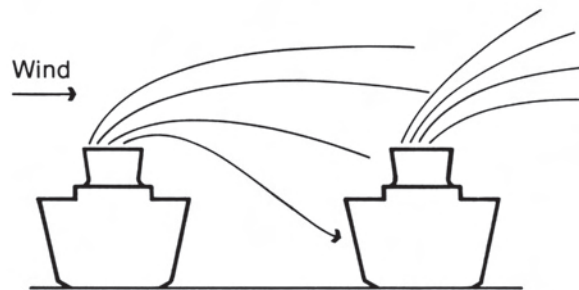

Figure 29 — Interference.

### 5. Interference

As previously indicated, local heat sources upwind of the cooling tower can elevate the wet-bulb temperature of the air entering the tower, thereby affecting its performance. One such heat source might be a previously installed cooling tower on site, or in the immediate vicinity. Figure 29 depicts a phenomenon called “interference”, wherein a portion of the saturated effluent of an upwind tower contaminates the ambient of a downwind tower. Although proper cooling tower placement and orientation (Sect. I-E-7-(c)) can minimize the effect of interference, many existing installations reflect some lack of long range planning, requiring that design adjustments be made in preparation for the installation of a new tower.

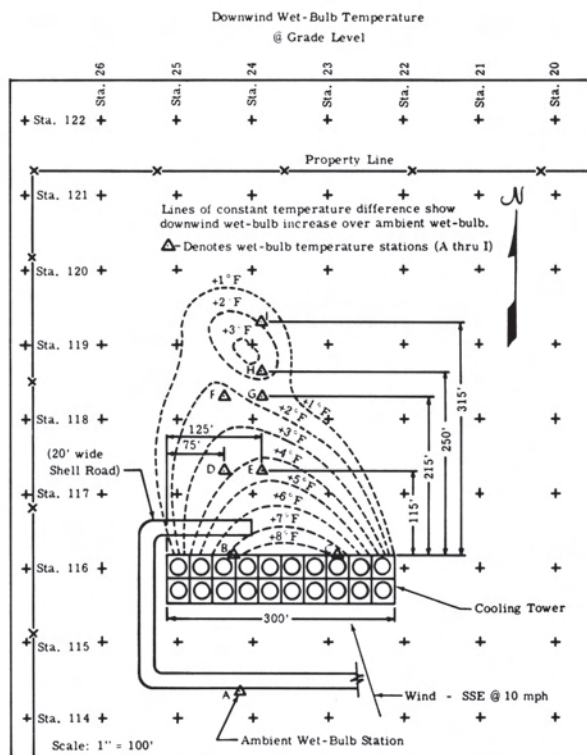

Figure 30 — Downwind wet-bulb contour of large existing cooling tower.



Figure 30 indicates the increase in wet-bulb temperature profile downwind of a large, poorly oriented cooling tower operating broadside to a 10 mph wind, based upon actual readings taken at grade level. If the only available location for a new tower were 300 ft. NNW of this tower, the specifier would be wise to select a design wet-bulb temperature at least 3 degrees higher than local conditions would otherwise indicate. However, at a given cold water temperature requirement, this would be equivalent to reducing the approach by about 3 degrees, which Figure 27 reveals would have a significant impact upon the cost of the new tower. Obviously, if any other location for the new tower is available, it should be placed out of the lee of the existing tower.

#### 6. Recirculation

Article E-1 of this Section described the important differences between ambient and entering wet-bulb temperatures. The latter can be, and usually is, affected by some portion of the saturated air leaving the tower being induced back into the tower air inlets.

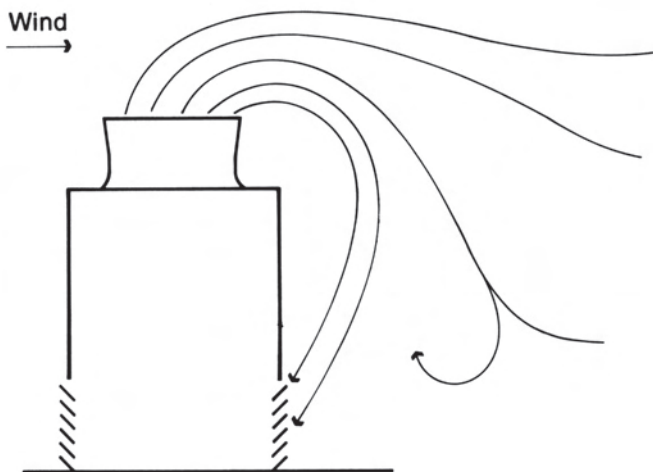

Figure 31 — Recirculation.

This undesirable situation is called “recirculation”, and reputable cooling tower manufacturers devote much research and development time both to determining the potential for recirculation under various wind conditions, and to designing their towers in such a way as to minimize its effect.

The potential for recirculation is primarily related to wind force and direction, with recirculation tending to increase as wind velocity increases. For that reason, accepted codes under which cooling towers are tested for thermal performance limit wind velocity during the test to 10 mph. Without this, and similar limitations, cooling tower testing and design would become infinitely more uncertain and difficult.

Although wind is the primary cause of recirculation, several other aspects of cooling tower design and orientation play important parts in its reduction and control:

a. **Tower Shape:** When flowing wind encounters an obstruction of any sort, the normal path of the wind is disrupted and a reduced-pressure zone or “wake” forms on the lee side (downwind) of that obstruction. Quite naturally, the wind will try to fill this “void” by means of the shortest possible route. If the obstruction is tall and narrow, the wind easily compensates by flowing around the vertical sides. However, if the structure opposing the wind is long and relatively low, the quickest path for pressure equalization is over the top – and downward.

Figure 30 is an exaggerated (although actual) example of what can happen in this situation. Note that the air inlet on the north face of the tower is experiencing wet-bulb temperatures some 6 to 7 degrees higher than that seen by the south face. The resultant increase in enthalpy of the entering air has, of course, degraded thermal performance tremendously.

Wind flows in a much more civilized fashion around a round cylindrical shape (Fig. 32), creating an almost negligible zone of reduced pressure on the downwind side; the air requirements of which are easily satisfied by streamlined flow around the shape. Application of this principle to the design of large cooling towers has resulted in extremely stable performance levels for critical projects. (See Fig. 35 also)



Figure 32 — Round mechanical draft tower operating in a significant wind. Compare plume rise to flat trajectory of smoke leaving stack.

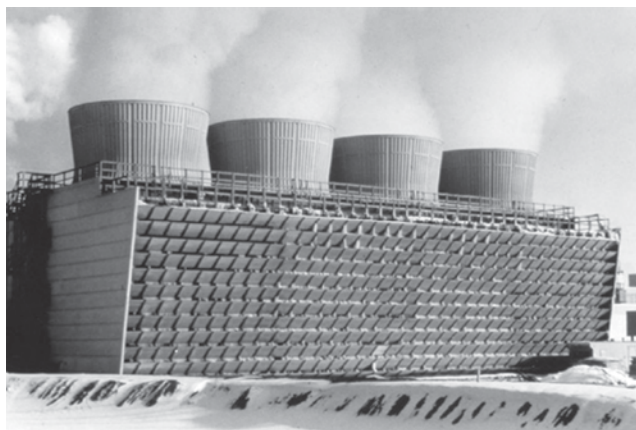

Figure 33 — Longitudinal wind direction concentrates separate stack plumes into one of high buoyancy.

b. **Orientation with Prevailing Wind:** If the wind indicated in Figure 30 is blowing in its prevailing direction, the Owner would have been well advised to turn the tower 90 degrees from its indicated orientation, as has been done in Figure 33. With this orientation, the wind first encounters the relatively high, narrow end of the tower, and the small negative pressure zone at the far end is easily filled by wind flowing around the vertical sides. Furthermore, wind moving parallel to the line of fans causes the separate effluents from each fan cylinder to “stack up” one on another, forming a concentrated plume of greater buoyancy.

The Round Mechanical Draft tower (Fig. 32) is, of course, unaffected by wind direction, and the centralized clustering of the fans produces a concentrated buoyant plume.

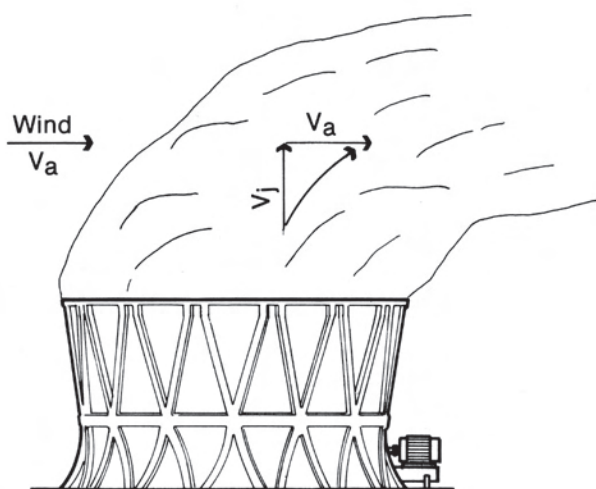

Figure 34 — Effect of wind velocity and discharge velocity on plume behavior.

c. **Air Discharge Velocity:** At any given atmospheric condition, the velocity at which the discharge plume from a tower will rise depends upon the kinetic energy imparted by the fan, and the effluent energy (decrease in density) imparted to the effluent plume by the tower heat load, both of which are changed to potential energy by virtue of ultimate elevation of the plume.

The direction that a plume will travel depends upon the speed, direction, and psychrometric characteristics of the wind it encounters upon leaving the fan cylinder. Low wind velocities ( $V_a$ , Fig. 34) will permit an almost vertical plume rise, barring retardation of that rise by unusual atmospheric conditions. **(For an induced draft tower operating under calm conditions, with a vertically rising plume, entering and ambient wet-bulb temperatures can be considered to be equal.)** Higher wind velocities will bend the plume toward the horizontal, where a portion of it can become entrapped in the aforementioned lee-side low pressure zone for re-entry into the tower. (Figs. 31 & 36)

The velocity ratio indicated in Figure 35 is the result of dividing the plume discharge velocity ( $V_j$ ) by the velocity of the ambient wind ( $V_a$ ). For all intents and purposes, the recirculation ratio is the percent of total effluent air that is reintroduced into the tower air inlets by virtue of recirculation. As can be seen, lower velocity ratios (higher wind velocities) result in greater recirculation. The values for the rectangular tower represent those anticipated for an industrial tower of moderate size operating broadside to the prevailing wind. The recirculation ratio for that tower would reach minimum value with a 90 degree directional change.

Since the velocity ratio is also a function of plume discharge velocity, ambient wind

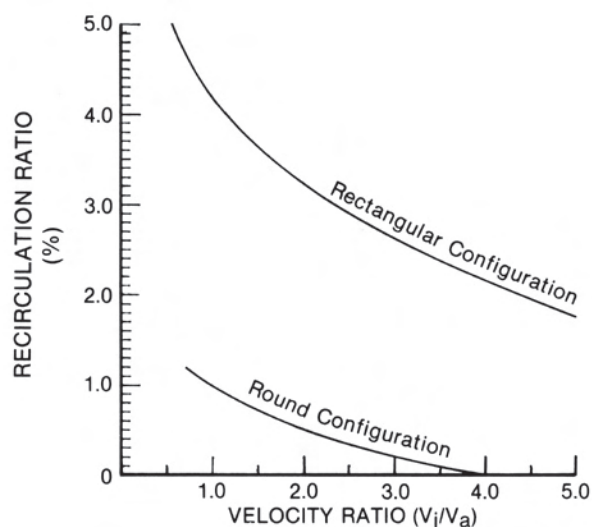

Figure 35 — Comparative recirculation potential of round and rectangular towers.

force cannot accept all of the blame for recirculation. At any given wind condition, the velocity ratio will decrease if the plume velocity is decreased, resulting in an increase in the recirculation ratio. This is what makes forced draft towers (Fig. 36) so susceptible to recirculation. The normal discharge velocity from an induced draft tower is about 20 mph, whereas the plume velocity leaving a forced draft tower is approximately 5-6 mph. Figure 35 reveals that this 4:1 difference in velocity ratios results in considerably greater recirculation in a forced draft tower.

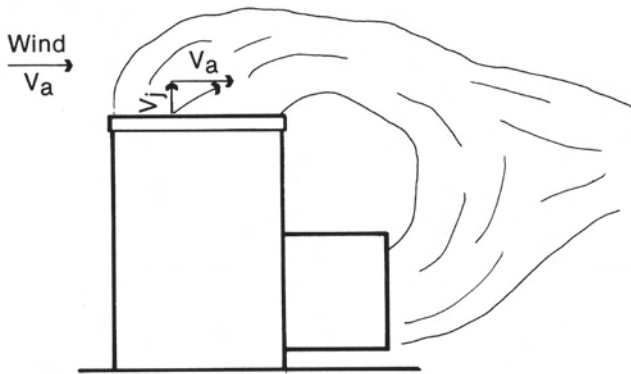

Figure 36 — Recirculation potential in a forced draft cooling tower.

d. **Fan Cylinder Height and Spacing:** Within structural limitations, discharge heights of fan cylinders can be increased. (Fig 100) Also, the fan cylinders can be spaced somewhat farther apart to allow for a less restricted flow of wind between them. Both of these stratagems, usually done in concert, can measurably diminish the potential for recirculation in most operating situations, although not without some impact upon tower cost.

Such specialized modifications will be covered in Section V of this manual.

#### 7. Tower Siting and Orientation

A significant portion of this text is devoted to the effects of recirculation and interference and, with expert guidance from the cooling tower manufacturer, **it is the responsibility of the Owner/specifier to situate the tower such that these and other thermal performance influencing effects will be minimized.** Since the long term capability of a cooling tower is determined by its proper placement on site, the importance of such placement cannot be overemphasized.

Every effort should be made to provide the least possible restriction to the free flow of air to the tower. In addition to this primary consideration, the Owner must give attention to the distance of the tower from the heat load, and the effect of that distance on piping and wiring costs; noise or vibration may create a problem, which can be expensive to correct after the fact;

drift or fogging may be objectionable if the tower is located too close to an area that is sensitive to dampness or spotting; also easy access and adequate working space should be provided on all sides of the tower to facilitate repair and maintenance work.

The performance of every cooling tower, large or small, is dependent upon the quantity and thermal quality of the entering air. External influences which raise the entering wet-bulb temperature, or restrict air flow to the tower, reduce its effective capacity. Air restrictions, recirculation and interferences can be minimized, possibly eliminated, by careful planning of tower placement using the following guidelines:

a. **Air Restrictions:** In residential, commercial, and small industrial installations, towers are frequently shielded from view with barriers or enclosures. Usually, this is done for aesthetic reasons. Quite often, these barriers restrict air flow, resulting in low pressure areas and poor air distribution to the air inlets. Sensible construction and placement of screening barriers will help to minimize any negative effect upon thermal performance.

Screening in the form of shrubbery, fences, or louvered walls should be placed several feet from the air inlet to allow normal air entry into the tower. When an induced draft tower is enclosed, it is desirable for the enclosure to have a net free area opposite each louvered face which is at least equal to the gross louver area of that tower face.

Screening barriers or enclosures should not be installed without obtaining some input concerning their design and placement from the cooling tower manufacturer.

b. **Recirculation:** Except in the case of single-flow towers (Sect. I-B-4), the proper placement to minimize recirculation is to orient the tower such that the primary louvered faces are situated parallel (**not** broadside) to the prevailing wind coincident with the highest ambient wet-bulb temperature. On towers of relatively shorter length, this allows the saturated effluent to be carried beyond the air inlets. Longer multiple-fan towers in this orientation benefit from the wind having concentrated the separate cell plumes into one of greater buoyancy.

Because of the restricted siting areas available in some plants, the Owner may have no choice but to orient towers broadside to a prevailing wind, and to adjust his design wet-bulb temperature accordingly. The amount of adjustment necessary can be reduced by recognizing that recirculation potential increases with the length of the tower (Fig. 30) and by splitting the tower into multiple units of lesser individual length with a significant air space in between. If, for example, the tower in Figure 30 had been installed as two 150 foot long towers in line, with a 50 foot space between

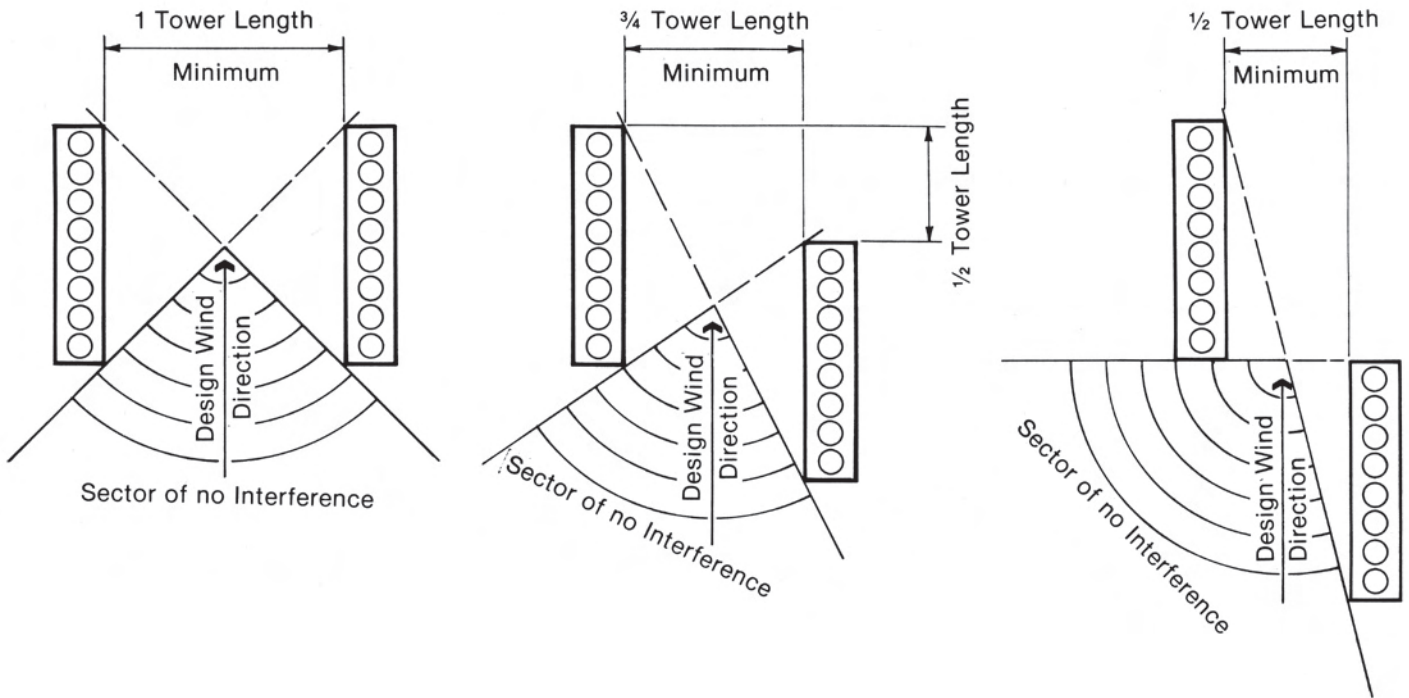
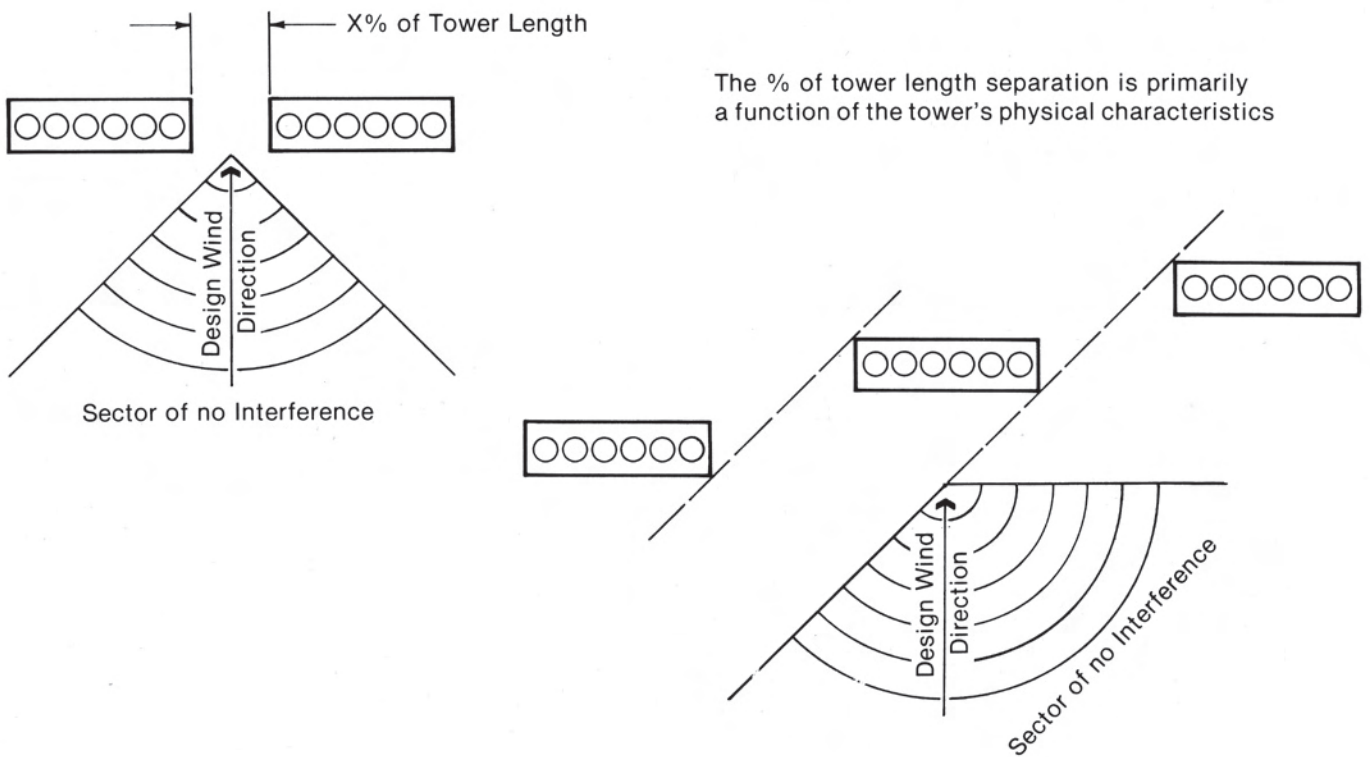

Figure 37 — Proper orientation of towers in a prevailing longitudinal wind. (Requires relatively minimal tower size adjustment to compensate for recirculation and interference effects.)



The % of tower length separation is primarily a function of the tower's physical characteristics

Figure 38 — Proper orientation of towers in a prevailing broadside wind. (Requires significantly greater tower size adjustment to compensate for recirculation and interference effects.)

the ends of the towers, the net amount of recirculatory effect may well have been halved.

- c. **Interference:** Similarly, multiple towers should not be situated such that any tower is within the downwind interference zone (lee) of another tower or extraneous heat source. If a tower is so located, then its design wet-bulb temperature should be adjusted appropriately.

Although the round tower indicated in Figure 32 suffers relatively little from recirculation, it is certainly not immune to interference from an upwind tower, nor will it hesitate to impact a downwind tower under certain atmospheric conditions.

- d. **Effect on Site Piping:** The need for proper siting and orientation is fundamental to a tower's ability to cool water dependably, and must take precedence over any concern as to the quantity or complexity of site piping required to accommodate the appropriate cooling tower layout. On relatively small installations, the extent of cooling tower relocation that may be required usually has an insignificant impact on total piping cost. Large multi-tower projects, however, typically require several hundred feet of pipe of appreciable diameter, representing

a portion of the overall project cost that is anything but insignificant.

As will be seen in Section II-D, the multiplicity of water distribution system arrangements available on crossflow cooling tower designs coordinate to reduce the required site piping to a minimum for rectilinear tower layouts. As can be seen in Figure 39, however, most effective reductions in site piping requirements occur when either hyperbolic or round mechanical draft towers are chosen. This is because of their inherent tolerance to much closer spacing.

Obviously, there are no rules of thumb which will cover every conceivable situation. Nor are the indicated guidelines intended to take the place of direct contact and discussion with a reputable cooling tower manufacturer. Considering that the location and orientation of the tower can impact the entering wet-bulb temperature from as little as 0.5°F, to as much as 3°F to 5°F, the user would be wise to invite as much expert assistance as possible. On certain critical projects involving appreciable heat loads, it may well be advisable to consider site-modeling for wind tunnel study.

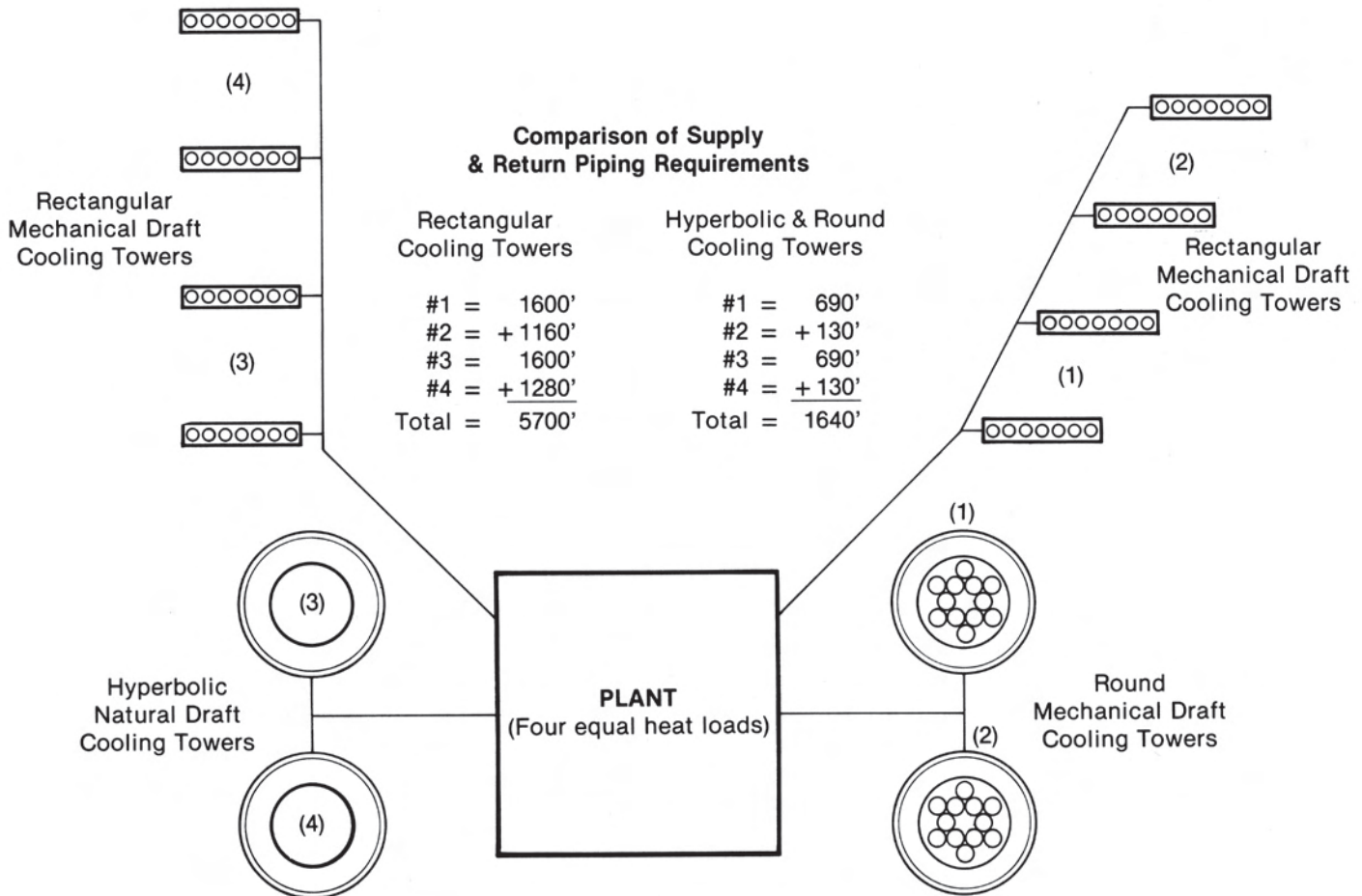

Figure 39 — Comparison of piping and ground use for both rectilinear towers and round towers. (Both types selected for equal performance.)

## F. MATERIALS OF CONSTRUCTION

Mention of typical materials utilized for specific components is made throughout this text, as appropriate. This portion, therefore, will be somewhat reiterative in its identification of "standard" construction materials; but will cover in greater depth why those materials were chosen, and will indicate the primary alternatives utilized to satisfy unique requirements. The impact of water quality on material selection will be discussed in Article G following. Other effects will be covered in Section V, "Specialized Tower Usage and Modifications".

1. **Wood:** Because of its availability, workability, relatively low cost, and its durability under the very severe operating conditions encountered in cooling towers, wood remains a commonly utilized structural material.

Having met these requirements admirably, Douglas Fir is used extensively in the cooling tower industry. It began to compete with California Redwood as the preferred material in the early 1960s, and has since established a record of success rivaling that of redwood. Douglas Fir plywood, in exterior grades, is also widely used as decking, partitions, and basin flooring materials.

Various other wood species, both domestic and foreign, may be used in cooling towers, provided that they exhibit proven durability in severe exposures and meet the physical and structural requirements of the installation.

Regardless of specie, however, any wood used in cooling tower construction must be treated with a reliable preservative to prevent decay. CCA is a waterborne preservative consisting of inorganic chromium, copper, and arsenic which has been used to treat cooling tower wood in the U.S. for over 50 years. The copper and arsenic are fungicides, while chromium acts primarily as a chemical fixing agent by reacting with natural chemicals in wood and forming insoluble, leach-resistant compounds with the copper and arsenic. Preservatives are diffused into the wood by total immersion in a pressure vessel, with pressure being maintained either until a prescribed amount of preservative is retained by the wood, or until the wood refuses to accept further treatment. In either case, laboratory tests, as well as historical records, have proven the treatment to be adequate.

Creosote treatment is used occasionally, although it adds considerably to the tower cost due to difficulties encountered in handling the treated wood. Also, its greater tendency to leach out of the wood can lead to heat transfer problems, and may complicate maintenance of water quality.

Although wood is relatively insensitive to chlorides, sulfates, and hydrogen sulfide, it can be damaged by excessive levels of free chlorine, and is sensitive to prolonged exposure to excessively hot water. Design hot water temperatures should be limited to 140°F, or should be controlled to that level by the use of a cold water by-pass, as described in Section V-I-1.

2. **Metals (Hardware):** Steel is utilized for many components of the cooling tower where high strength is required. This would include fan hubs for larger diameter fans; unitized supports for stabilization of the mechanical equipment; many driveshafts (although stainless steels are normally used for the larger shafts); fan guards and driveshaft guards; as well as the tie rods, bolts, nuts and washers.

In the overwhelming majority of cases, circulating water conditions will be considered normal, and the coating of choice for steel items will be galvanization. For severe water service, those components whose requirements are not economically met by alternative materials are usually coated with epoxy-coal-tar.

Cast iron and ductile iron are used for gear cases, anchor castings, flow control valve bodies, and fan hubs for intermediate sized fans. Although both cast iron and ductile iron enjoy good corrosion resistance, they are usually either galvanized or coated with a high grade enamel for cooling tower use. For severe water service, however, they are usually sand-blasted and coated with epoxy-coal-tar. Valve bodies may even be porcelainized to guard against erosion.

Bolts, nuts and washers, of course, do not lend themselves to a pre-coat, other than galvanization or cadmium plating. Severe water conditions normally dictate a change in materials, and an appropriate grade of stainless steel is the popular choice because of excellent corrosion resistance in the aerated conditions existing in cooling towers.

Copper alloys are sometimes used to resist special conditions, such as salt or brackish water service. Silicon bronze fasteners are suitable for service in salt water, but must be protected against erosion. The use of Naval brass is normally discouraged because of its tendency toward stress corrosion cracking. Utilization of more sophisticated metals, such as monel and titanium, is usually precluded by cost considerations.

Selection of aluminum alloys for use in cooling towers is done with care. Only the more corrosion resistant alloys are used, and they are utilized only for specific components of significant cross section. Among these components are fan blades, fan hubs for smaller size fans, some ladder assemblies, and handrail fittings for steel framed cooling towers.

Most of the smaller towers designed for factory assembly are primarily of steel construction. Some local building and/or fire codes also dictate that larger towers be of steel construction as well. In these cases, galvanized steel is used for structures, basins, partitions, decking, fan cylinders, and many other major components. In selected applications of extreme severity, such towers have been successfully manufactured of stainless steel, although the cost impact was significant as might be expected.

3. **Plastics:** The use of selected plastics began to be investigated in the early 1950s and, since that time, has accelerated tremendously with pultruded fiberglass becoming the most commonly used structural material in recent years. PVC has been the most commonly used fill material for some time. Contributing to this increased usage are their inherent resistance to microbiological attack, corrosion and erosion; their compatibility with other materials; their formability; their great strength-to-weight ratio; and their acceptable cost level.

The capability of plastics to be molded into single parts of complex shape and dimensions is a distinct advantage, particularly for such close-tolerance components as fan blades and fan cylinders. Their many desirable characteristics, combined with the advancements being made in both plastic materials and their production, assure that they will continue to be utilized for cooling tower components, and the rate of usage is anticipated to increase.

Plastics are currently used in such components as pultruded structural members, structural connectors, fan blades, fan cylinders, fill, fill supports, drift eliminators, piping, nozzles, casing, louvers, and louver supports. Most commonly used are fiber reinforced polyester (FRP), fiber reinforced epoxy, polyvinyl chloride (PVC), polypropylene, and fiber reinforced nylon.

Generally speaking, plastic components are of a dimension, location, or formulation that makes them least susceptible to abnormal water conditions. However, the relatively thin cross section utilized for PVC film fill sheets makes them somewhat sensitive to temperature, requiring something more than routine thought in fill support design. Some plastics, such as PVC, are inherently fire resistant. Where required, others may be formulated for fire retardancy. The most common such formulation being fire retardant fiber reinforced polyester, utilized for casing and louvers.

4. **Concrete:** Concrete has been used for many years in Europe and other regions of the world, and its use is increasing in the United States. Following the first concrete hyperbolic cooling tower installed in the USA in 1961, numerous others have been installed, and the technology has been expanded to large mechanical draft towers. In many cases, the higher first cost of concrete construction is justified by decreased fire risk and, for larger structures, higher load carrying capacity.

Basically, design philosophies for concrete cooling tower construction coincide with those espoused by the American Concrete Institute (ACI), except denser mixes and lower water/cement ratios are utilized than would be expected in more commercial construction. Typically, Type I cement is utilized, except where the presence of above-normal sulfate concentrations dictate the use of Type II in water-washed areas.

Circulating water in want of calcium (qualified by a negative Saturation Index) can be corrosive

to concrete components, in which case the concrete gives up a portion of its calcium content in an effort to "neutralize" the water. Chemical treatment of the circulating water should be aimed at maintaining a slightly positive Saturation (Langelier) Index. (Formula (7), pg. 32)

## G. MAINTAINING WATER QUALITY

Although the air quality at any particular site can be the cause of serious adverse effects upon both a cooling tower's longevity of service, and its ability to function thermally, it usually manifests itself in an undesirable, perhaps unexpected, change in **water quality**. This is because **cooling towers are extremely effective air washers**, and the technological advances which are intended to improve their thermal performance also serve to increase their air washing efficiency. Consequently, the quality of the water being circulated over a tower quickly reflects the quality of the air with which it is in intimate contact. Meanwhile, of course, the air exits a cooling tower much cleaner than its entering state.

This constant washing of the incoming air, plus the base characteristics of the make-up water supply, are the parameters which establish the ultimate quality of the continuously recirculated water stream, complicated by the fact that the process of evaporation has the ability to cause incoming contaminant levels to concentrate tremendously. (See "Blowdown" following)

In order to establish a basis for the utilization of standard construction materials, the following "normal" water conditions have become arbitrarily defined:

- a. A circulating water with a pH between 6 and 8; a chloride content (as NaCl) below 750 ppm; a sulfate content ( $\text{SO}_4$ ) below 1200 ppm; a sodium bicarbonate ( $\text{NaHCO}_3$ ) content below 200 ppm; a maximum temperature of 120°F; no significant contamination with unusual chemicals or foreign substances; and adequate water treatment to minimize corrosion and scaling.
- b. Chlorine, if used, added intermittently, with a free residual not to exceed 1 ppm, maintained for short periods.
- c. An atmosphere surrounding the tower no worse than "moderate industrial", where rainfall and fog are only slightly acid, and they do not contain significant chlorides or hydrogen sulfide ( $\text{H}_2\text{S}$ ).

Water conditions falling outside these limits would warrant an investigation of the combined effect of all the constituents on each component material. In many cases, it will be found that very few components require a change in materials. Wood and plastic components, for example, are very tolerant of chemical excursions far beyond these limits. Conversely, carbon steel items are relatively unforgiving of all but the most limited variations.

1. **Blowdown:** As indicated previously, the water of evaporation exits the tower in a pure vapor state, leaving behind its burden of total dissolved (TDS) to concentrate in the recirculating mass of water. Given no control, the TDS level in

the circulating water will increase tremendously, jeopardizing not only the cooling tower, but the heat exchanger and all other water circuit related components as well.

The proper method for controlling TDS concentrations is called "blowdown", where a portion of the circulating water flow (along with its TDS burden) is continuously wasted and replenished with relatively pure make-up water.

The approximate level to which contaminants can concentrate in the circulating water is determined by the following formula:

$$C = \frac{E + D + B}{D + B} \quad (2)$$

Where: E = Rate of evaporation; gpm (If not accurately known, evaporation can be approximated by multiplying total water flow rate in gpm times the cooling range (°F) times 0.0008 (3)

D = Rate of drift loss; gpm (If not accurately known, drift rate can be approximated by multiplying total water flow rate in gpm times 0.0002) (4)

B = Rate of blowdown; gpm

However, because an acceptable level of concentration has usually been predetermined, the operator is more concerned with the amount of blowdown necessary to maintain that concentra-

tion, and the following transposition of Formula (2) is used:

$$B = \frac{E - [(C - 1) \times D]}{(C - 1)} \quad (5)$$

For example, let us assume that a given cooling tower is designed to reduce the incoming temperature of 10,000 gpm by 25°F (range). Let us further assume that the level of chlorides in the make-up water is 250 ppm, and we do not want that level to go beyond 750 ppm in the circulating water. Allowable concentrations are 750/250 = 3. The approximate evaporation rate would be 10,000 x 25 x 0.0008 = 200 gpm. The approximate drift rate would be 10,000 x 0.0002 = 2 gpm. Applying these values to Formula (5), blowdown would be:

$$\frac{200 - [(3-1) \times 2]}{(3 - 1)} = \frac{200 - (2 \times 2)}{2} = \frac{200 - 4}{2} = \frac{196}{2} = 98 \text{ gpm}$$

Even if the assumed evaporation and drift rates were perfectly accurate, the calculated blowdown rate of 98 gpm might still not be quite enough because of the effects of the aforementioned airborne contaminants, which are usually incalculable. Once the approximate level of blowdown has been determined, the circulating water quality should be regularly monitored and appropriate adjustments made.

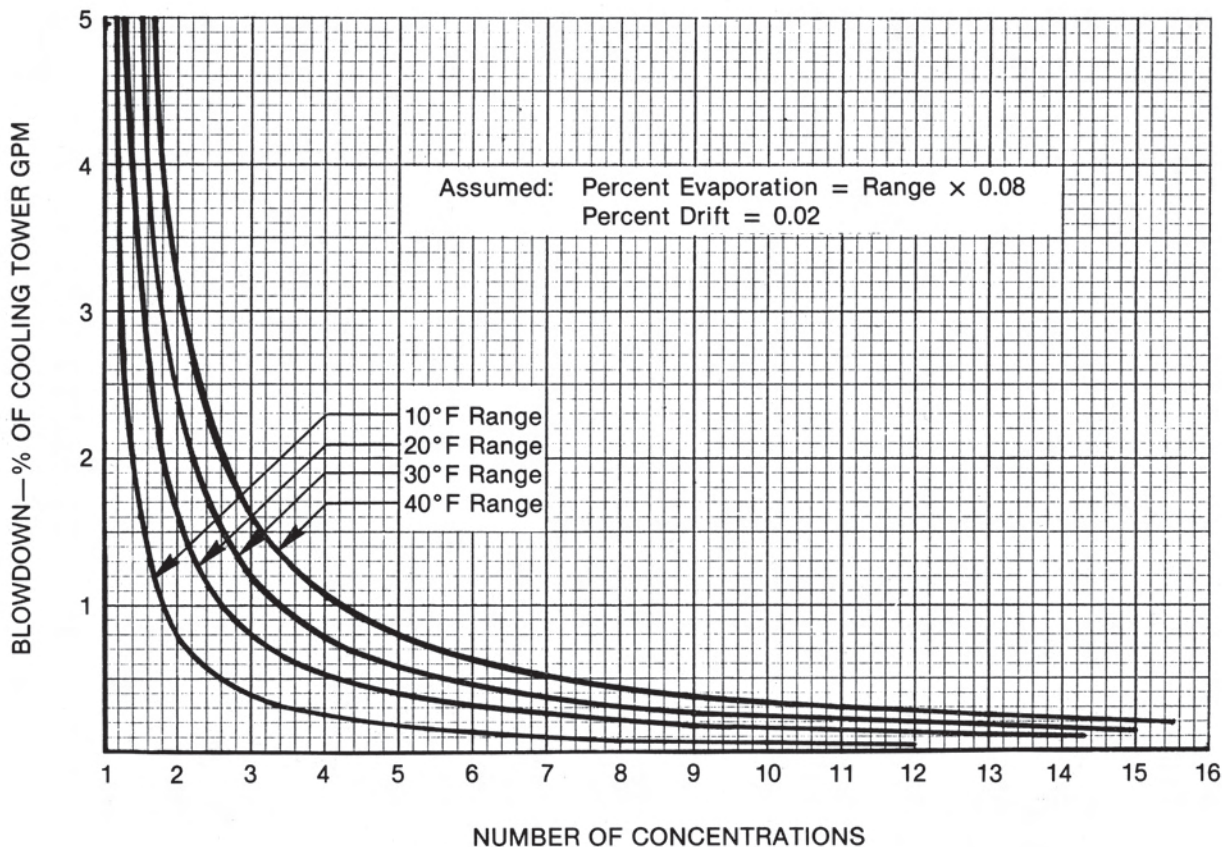

Figure 40 — Cooling tower blowdown versus number of concentrations.



Figure 40 is a plot of the percent of circulating water flow to be wasted in order to maintain various concentrations, based upon the approximate evaporation and drift rates indicated by Formulas (3) and (4), expressed as percentages.

Despite the benefits of blowdown, however, chemical, electrostatic, or electronic treatment of the water is often required to prevent scale formation, corrosion, or biological growth. When treatment is required, or anticipated to be required, ***the services of a reliable water treatment company should be obtained.***

2. **Scale Prevention:** The principle scale-forming ingredient in cooling water is calcium carbonate, which has a solubility of about 15 ppm and is formed by the decomposition of calcium bicarbonate. The maximum amount of calcium bicarbonate that can be held in solution depends upon the temperature and the free carbon dioxide content of the water. Raising the temperature or reducing the free carbon dioxide, at the point of equilibrium, will result in the deposition of scale.

If agents (such as sulfuric acid) are added to convert a portion of the calcium bicarbonate to calcium sulfate, the resultant concentration of calcium sulfate should not be allowed to exceed 1200 ppm (expressed as  $\text{CaCO}_3$ ). Otherwise, sulfate scale may begin to form, which is very dense and quite difficult to remove. Treatment companies may also advise the use of selected compounds designed to keep scale-forming solids in solution.

The Langelier equation can be used to determine the carbonate stability, or corrosive properties, of a cooling water for a specific temperature when dissolved solids, total calcium, total alkalinity, and pH values are known. The Saturation Index (See Formula (7) and Table 2), obtained from these values, is the difference between the actual measured pH and the calculated  $\text{pH}_s$  at saturation with calcium carbonate. When the Saturation Index is zero, the water is in equilibrium with solid  $\text{CaCO}_3$  at that temperature; when it is positive, the water is supersaturated with  $\text{CaCO}_3$  and may deposit a coating or scale in the system; when it is negative, the water will dissolve  $\text{CaCO}_3$  and may be corrosive.

The Ryznar equation was developed to provide a closer correlation between the calculated prediction and the quantitative results actually obtained in the field. The numerical value obtained from this equation is designated as the Stability Index. A value of 6 to 7 indicates a water which is the most balanced. Values less than 6 are in the area of scaling, while values above 8 indicate increasing corrosion tendencies.

It should be emphasized that these indices are only a measure of the directional tendency, or driving force, of a water. Since the solubility of calcium carbonate is dependent on temperature, the water in a cooling system will have a different index for each temperature encountered. In prac-

tice, the indices are used to arrive at a calculated method of treatment. Removable lengths of pipe, or metal coupons, should be inspected periodically to confirm that the treatment is in balance. If objectionable scaling is occurring, an increase in acid feed may be required. If corrosion is evident, a reduction of acid feed, or the introduction of a lime or soda ash solution, may be needed. For a system in which a considerable temperature spread occurs, and treatment is set to control scale laydown, it is frequently necessary to use an inhibitor to prevent corrosion in the low temperature areas. It is desirable to calculate both the Saturation Index and the Stability Index in order to most accurately predict the scaling or corrosive tendencies of a water.

The index values are calculated from the following equations, utilizing appropriate values obtained from Table 2:

$$\text{pH}_s = (9.3 + A + B) - (C + D) \quad (6)$$

Where:  $\text{pH}_s$  = pH value at which water is in equilibrium with solid  $\text{CaCO}_3$ .

A = Table 2 value reflecting total solids.

B = Table 2 value reflecting temperature.

C = Table 2 value reflecting calcium hardness.

D = Table 2 value reflecting alkalinity.

$$\text{Saturation Index} = \text{pH (actual)} - \text{pH}_s \quad (7)$$

$$\text{Stability Index} = (2 \times \text{pH}_s) - \text{pH (actual)} \quad (8)$$

3. **Corrosion Control:** The metals utilized in a cooling tower are susceptible to corrosion in varying degrees. This is often true of even the most sophisticated metals, although they can usually withstand deeper excursions into the realm of corrosion, and for longer periods of time, than can the more "standard" metals. Circulating water having corrosion characteristics beyond those anticipated in the tower's design requires treatment. This may be due to high oxygen content, carbon dioxide, low pH, or the contact of dissimilar metals. Where correction of the source of trouble cannot readily be made, various treatment compounds may be used as inhibitors which act to build and maintain a protective film on the metal parts.

Since most water system corrosion occurs as a result of electrolytic action, an increase in the dissolved solids increases the conductivity and the corrosion potential. This is particularly true of the chloride and sulfate ions. Therefore, blowdown is a very useful tool in the fight against corrosion.

4. **Control of Biological Growth:** Slime (a gelatinous organic growth) and algae (a green moss) may develop in the cooling tower, and their presence can interfere with cooling efficiencies. (See Sect. V-I) Proprietary compounds are available from water treatment companies for the control of slime and/or algae. Chlorine and

chlorine-containing compounds are effective algicides and slimicides, but excess chlorine can damage wood and other organic materials of construction. If used, chlorine should be added intermittently (shock treatment), and only as frequently as necessary to control slime and algae. Residual levels of free chlorine should not exceed one part per million parts of water (1 ppm). Chlorine or chlorine-containing compounds must be added carefully, since very high levels of chlorine will occur at or near the point of entry into the circulating water system, causing a localized reduction of pH and resultant corrosion.

5. **Foaming and Discoloration:** Heavy foaming can sometimes occur when a new tower is put into operation. This type of foaming usually subsides after a relatively short operating period. Persistent foaming can be caused by the concentrations of certain combinations of dissolved solids, or by the contamination of the circulating water with foam-causing compounds. This type of foaming is often alleviated by increasing the rate of blowdown. In extreme cases, foam depressant chemicals must be added to the system, which are available from a number of chemical companies.

Woods contain some water soluble substances, and these commonly discolor the circulating water on a new tower. This discoloration is not harmful to any of the components in the system, and can be ignored in that regard. However, a combination of foaming and discolored water can result in staining of adjacent structures when foam is entrained in the air stream and discharged out the fan cylinders. In those cases, operation of the fans should be avoided until the foaming is controlled.

6. **Control of Foreign Materials:** Suspended materials, brought into the system from the air, can best be removed by continuous filtration. (See Sect. VI-E) Oils and fats should be removed from the circulating water by means of a skimmer (See Sect. V-I-2) or, preferably, by eliminating the source of such contamination. Oils and fats are not only a fire hazard, but will reduce thermal performance of both the heat exchanger and the cooling tower.

## H. OPERATION IN FREEZING WEATHER

Cooling towers are designed to promote the maximum possible contact between air and water – and to do so for the maximum possible time period. This design endeavor results in an efficiency which, although greatly appreciated in the summertime, has the capability to produce performance-degrading ice formations during winter operation. Obviously, therefore, means by which the cooling tower's efficiency can either be controlled, or can be made to work toward the management of ice formations, must be incorporated into its design, and must be properly utilized by the operator.

In broadly general terms, "acceptable" ice may

be defined as ice of relatively thin cross section which forms on the louvers or air intake structure of the tower. (Fig. 41) Having been anticipated in a tower's design loading, such ice is normally of no structural concern and, in many cases, its retardation of air flow through the tower achieves a result similar to the air-side control procedures about to be discussed.

Equally broadly, "unacceptable" ice can be categorized as either a significant amount of ice that has formed on the fill, jeopardizing the operation and existence of the heat transfer surface; or excessive ice in a support region which may threaten the tower structure. (Fig. 42)

Although the methods of ice control vary somewhat with type of tower, as well as the water distribution system and mechanical equipment arrangements, the following statements are true for all situations:

- The potential for ice varies *directly* with the quantity of air flowing through the tower. Reducing the air flow retards the formation of ice.
- Where air flow is uncontrolled (as in the case of hyperbolic towers), the potential for ice formation varies *inversely* with the heat load imposed on the tower. A reduced heat load increases the probability that unacceptable ice will form.
- The potential for ice varies *inversely* with the amount of water flowing over the fill. A reduced pumping rate increases the likelihood of unacceptable ice formation.

All mechanical draft towers afford some degree of air-side control, the variability of which depends upon the number of fans with which the tower is equipped and, most importantly, the speed-change capability of the motors. Towers designed to be operated in cold climates also include means by which to exercise water-side control. In mechanical draft towers, both air-side and water-side control are mutually supportive. However, natural draft towers offer no reasonable opportunity for air-side control and, for that reason, the methods will be discussed separately, as follows:

### 1. Air-Side Control

The basic operating concepts that result in good energy management (Sect. V-F) also serve to reduce a cooling tower's ability to produce unacceptable ice formations. Manipulation of the air flow is an invaluable tool, not only in the retardation of ice formation, but in the reduction or elimination of ice already formed. In addition to bringing less cold air into contact with the circulating water, reducing the entering air flow velocity alters the path of the falling water, allowing it to impinge upon (and melt) ice previously formed by random droplets which wind gusts, or normal splashing, may have caused to escape the protection of the relatively warm mainstream of water.

Single-speed fans afford the least opportunity for airflow variation, and towers so equipped re-

SECTION I

quire maximum vigilance on the part of the user to determine the proper cyclic fan operation that will best control ice. Two-speed fan motors offer appreciably better operating flexibility, and should be the minimum mandatory requirement for towers to be used in freezing climates. Fans may be individually cycled back and forth between full-speed and half-speed as required to balance cooling effect and ice control, limited only by the maximum allowable motor insulation temperature which an abnormal number of speed changes per hour may cause to be exceeded. (Sect. IV-D)

Best ice control, consistent with proper operating procedures, is achieved by the use of variable frequency drives. Set to prevent tower water from dropping below a given temperature, these automatically reduce fan airflow as ambient temperature reduces.

On towers equipped with a separate plenum for each fan, individual fans may also be shut off, providing another increment of flexibility. However, on towers having two or more fans evacuating a common plenum, those fans should be brought to the off position in unison to prevent a downdraft of cold, moisture laden air from icing up the mechanical equipment of an inoperative fan.

Ultimately, severe ice formations may require that the fans be reversed for a period of time. This causes the falling water pattern to be shifted outward, bringing a deluge of relatively warm water in contact with ice formations for rapid melting. The warmed air exiting the air inlets also promotes melting of ice formations not reached by the falling water. This mode of operation should be utilized only for short periods of time due to the possibility of ice forming on the fan cylinders, fan blades, and mechanical equipment. The allowable length of time will be

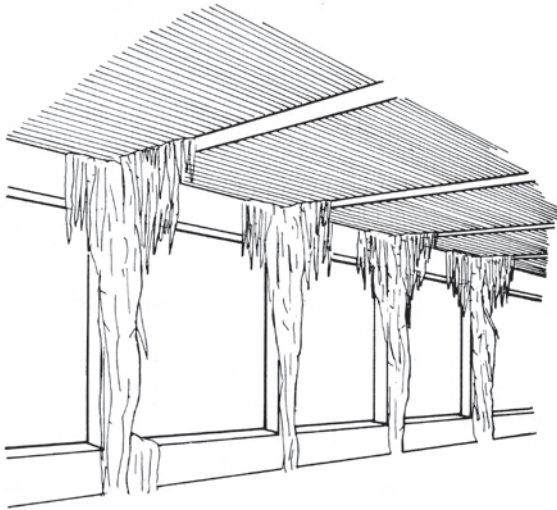

Figure 41a — "Acceptable" counterflow ice.

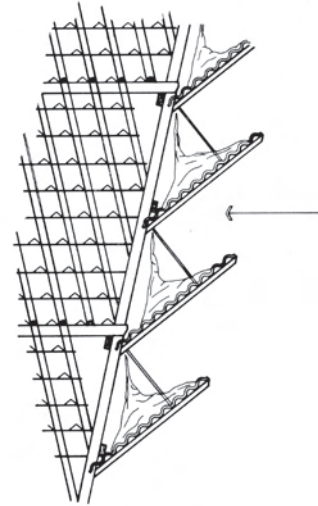

Figure 41b — "Acceptable" crossflow ice.

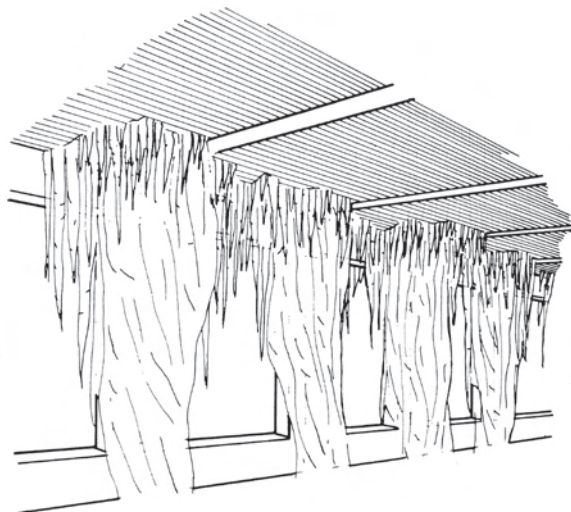

Figure 42a — "Unacceptable" counterflow ice.

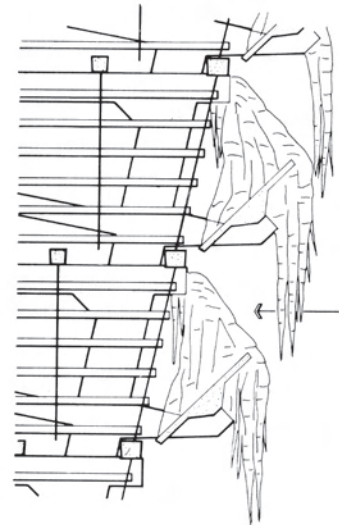

Figure 42b — "Unacceptable" crossflow ice.

a function of atmospheric conditions and should be established, and monitored, by the operator. On multi-fan towers, individual fan reversal should be avoided. Otherwise, the discharge vapors from adjacent fans may cause severe icing of a reversed fan.

## 2. *Water-Side Control*

All large towers, regardless of type, which are designed for operation in freezing weather should be equipped with a water distribution system which can be manipulated to place the greatest concentration of flowing water nearest the air intakes of the tower. This is particularly true in the case of natural draft towers (Fig. 3) where no means of air-side control is available. Not only does this give the most difficult cooling job to the coldest air, but it also assures a rapid rise in air temperature to preclude freezing within the fill. Most importantly, it places the maximum amount of relatively warm flowing water in close proximity to the areas of greatest ice concern.

Since the potential for freezing on the fill depends so much upon the incoming water temperature, provision for total water by-pass directly into the cold water basin (Fig. 43) is advisable on

mechanical draft towers, and should be considered mandatory on natural draft towers. During cold weather start-up, the basin water inventory may be at a temperature very near freezing, at which time the **total** water flow should be directed back into the cold water basin upon its return from the process load, without going over the fill. This by-pass mode should be continued until the total water inventory reaches an acceptable temperature level (usually about 80°F), at which time the by-pass may be closed to cause **total** flow over the fill.

Even during operation, combinations of low-load and low-ambient can promote ice formations despite normal air-side and water-side control procedures. In those cases, it may be necessary to divert to **total** by-pass flow in order to maintain a reasonable basin water temperature. Modulation of by-pass, whereby a portion of the water flow is allowed to continue over the fill, **must** not be allowed to occur on a natural draft tower, and its utilization on mechanical draft towers should be discouraged unless 1) very fine air-side control is maintained, 2) the water distribution system has the capability to con-

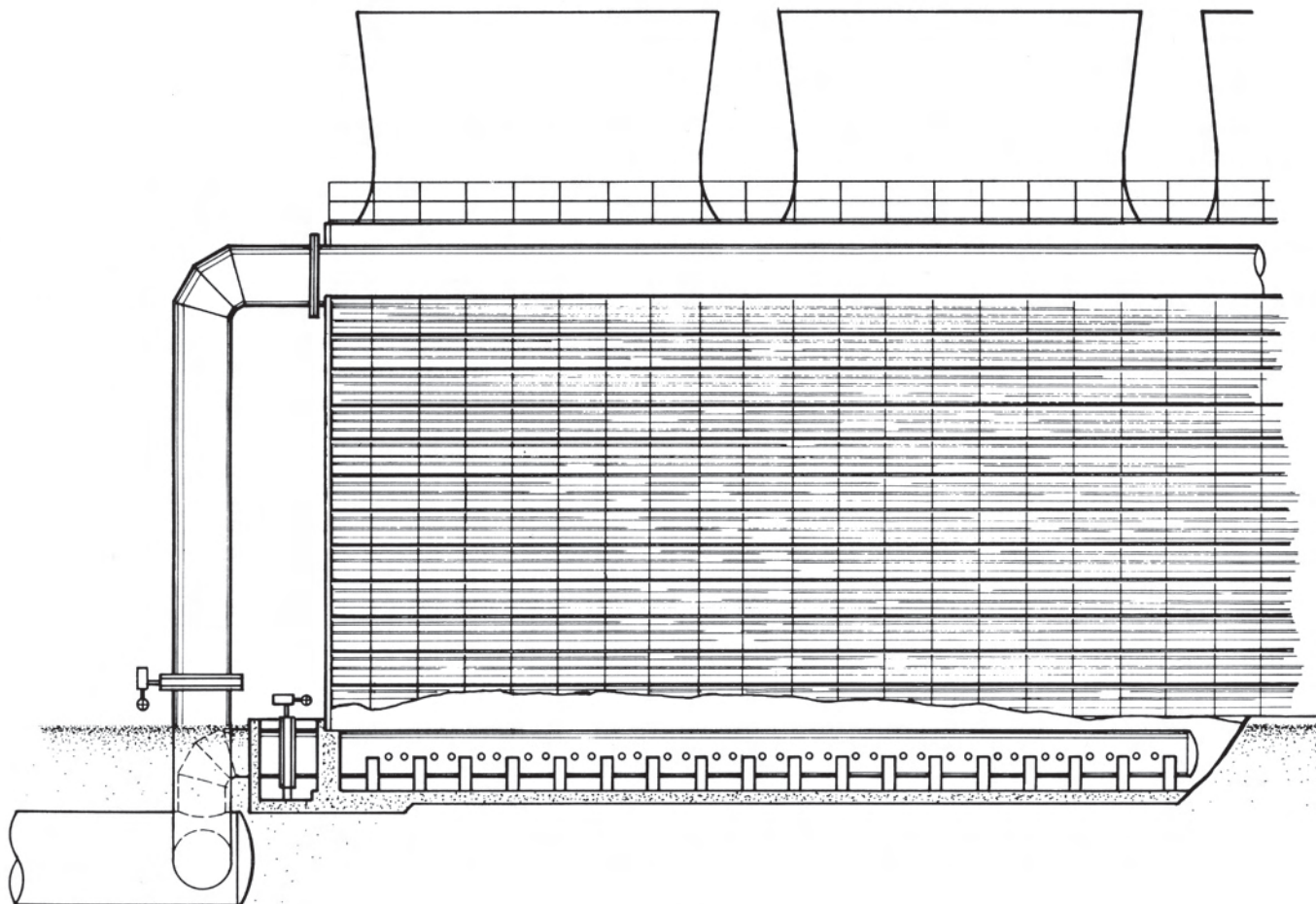

Figure 43 — Typical piping and valving arrangement to by-pass return water directly into the cold water basin.

## SECTION I

concentrate water flow to the outboard portions of the fill, and 3) the operator monitors the tower's condition vigilantly. Even so, fill flow rates of less than 50 percent *must* not be allowed.

Of the two basic types of towers utilized (counterflow and crossflow) neither can be considered to have an overriding advantage over the other in terms of cold weather operation. Although the counterflow tower's configuration tends to confine ice formations to areas of greatest structural strength, it is also the most difficult to de-ice. This is because their straight-sided shape reduces the opportunity for direct warm water contact with a major ice formation, requiring more frequent fan reversal.

Crossflow towers have an inwardly sloping air inlet face which assures continuous contact of warm water with critical areas and, with only occasional fan reversal, promotes rapid de-icing.

This manual is not intended to offer precise instructions on cold weather operation of a particular tower, but is meant to raise the level of understanding and awareness of potential users and practitioners. Precise instructions for individual cases should be obtained from the manufacturer.

Measures for the prevention of basin freezing in an inoperative tower are covered in Section VI of this manual.

## Structural Components

### A. GENERAL

The structure of a cooling tower must accommodate long duration dead loads imposed by the weight of the tower components, circulating water, snow and ice, and any build up of internal fouling; plus short term loads caused by wind, maintenance and, in some areas, seismic activity. It must maintain its integrity throughout a variety of external atmospheric conditions, and despite a constant internal rainstorm. Wide-ranging temperatures must be accepted, as well as the corrosive effects of high humidity and constant oxygenation.

Were it not for the fact that a cooling tower structure must also provide the least possible impedance to the free contact of air and water, the solution to the above problems would be relatively routine. That requirement, plus the constant vibratory forces imposed by mechanical equipment operation, dictate structural considerations, and variations, which are unique to the cooling tower industry. Although basic design concepts are predicated upon universally accepted design codes, reputable cooling tower manufacturers will modify these codes as necessary to compensate for effects deemed not to have been foreseen by the original authority.

The components to be considered in this Section are the cold water basin, framework, water distribution system, fan deck, fan cylinders, mechanical equipment supports, fill, drift eliminators, casing, and louvers. The best materials for these components are continuously sought, along with improved techniques for integrating them into a stable, dependable, long lasting unit.

### B. COLD WATER BASIN

The cooling tower basin serves the two fundamentally important functions of 1) collecting the cold water following its transit of the tower, and 2) acting as the tower's primary foundation. Because it also functions as a collection point for foreign material washed out of the air by the circulating water, it must be accessible, cleanable, have adequate draining facilities, and be equipped with suitable screening to prevent entry of debris into the suction-side piping.

1. **Basin Types:** Ground level installations, typical of virtually all large industrial towers, utilize concrete basins (Fig. 44) almost exclusively, whereas elevated or rooftop installations are normally equipped with basins provided by the cooling tower manufacturer, compatible with the cooling tower framework. Typical materials include wood (Fig. 45), steel and, occasionally, plastic. In those cases, the cooling tower manufacturer usually includes drain and overflow fittings, make-up valve(s), sumps and screens, as well as provisions for anchorage.

Concrete basins for wood or steel framed, field-erected towers (Fig. 44) are usually designed and built by the purchaser, utilizing dimensional and load information provided by the manufacturer. However, due to their integration into the overall tower structure, and because of the extensive site-related concrete work required, cold water basins for concrete towers (Fig. 46) are often both designed and built by the cooling

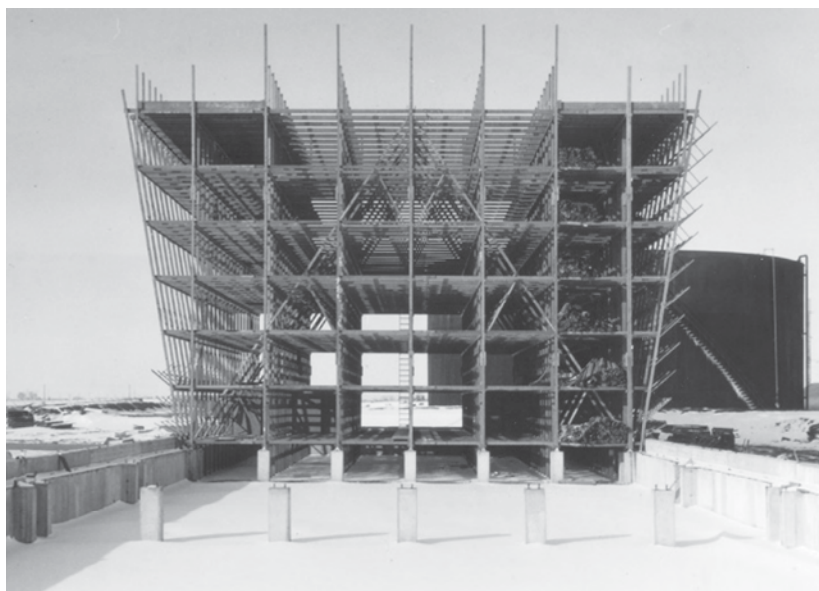

Figure 44 — Crossflow tower framework on concrete basin prepared for future tower extension.

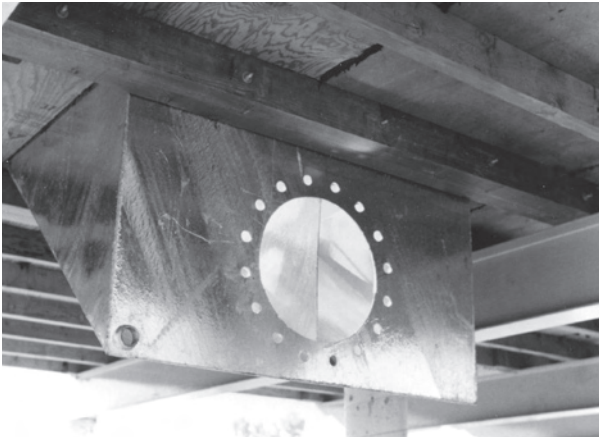

Figure 45 — Plywood cold water basin floor. (Note depressed sump)

tower manufacturer.

To insure proper functioning of the tower, the basin must provide a stable, level foundation. Generally, a well-drained soil with moderate bearing capacity will support mechanical draft towers of wood or steel construction. Concrete towers impose heavier loads on the soil and, in some cases, may require the use of piles or caissons. The soil should have a uniform bearing capacity under the basin to prevent uneven settlement. Footings must be below the prevailing frostline (Fig. 47), and construction practices should always conform to local codes.

Wood and fiberglass towers may be equipped with wood, fiberglass or steel basins. Wood basins are normally flat, less than 2' deep, and equipped with depressed sumps to facilitate pump suction. Joints are sealed to prevent leakage. Plywood basins typically require considerably less maintenance than do carbon steel

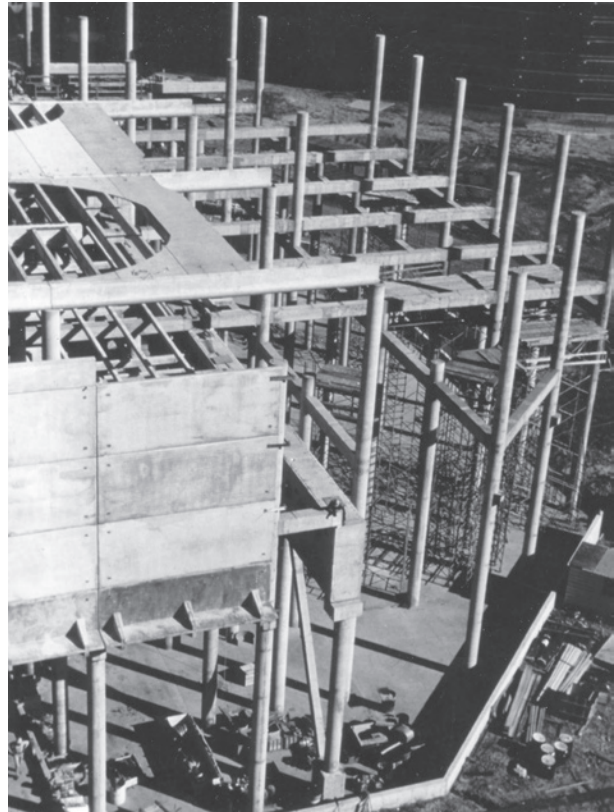

Figure 46 — Basin and basic framework of an octagonal mechanical draft tower in concrete construction.

basins. Fiberglass basins are typically used with fiberglass tower structures.

Steel basins may be of carbon steel (galvanized or painted), or stainless steel, and of either bolted or welded construction. If bolted, joints must be gasketed and sealed leak-tight. If welded, the weld vicinity should be suitably

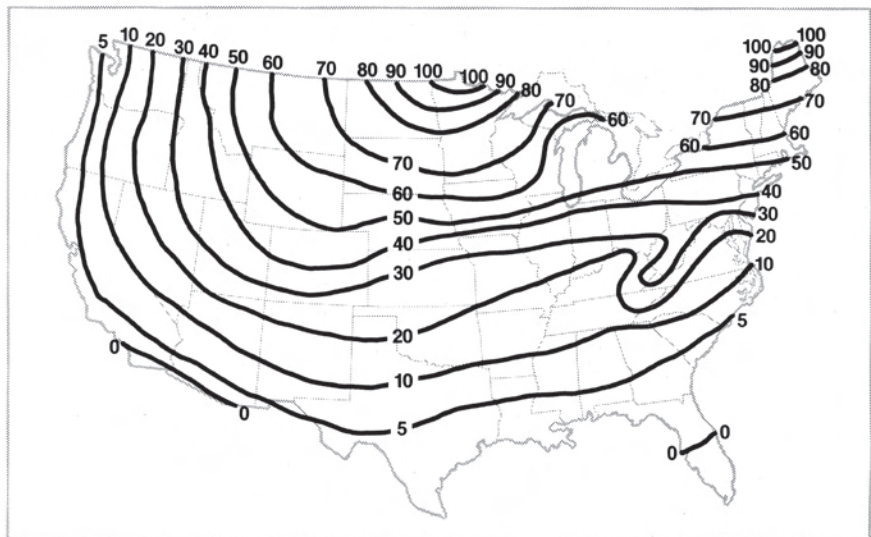

Figure 47 — Extreme depth of frost penetration (in.) based on state averages.

coated for corrosion protection. Steel basins also are normally flat, except for those under certain factory-assembled towers (Fig. 12), which incorporate a depressed section to facilitate cleaning and improve outflow characteristics. Being subject to oxidation, steel basins require more maintenance, and are more sensitive to water quality, than are wood basins.

2. **Basin Support:** A grillage of steel or concrete is normally utilized for support of a tower installed over a wood or steel basin. (Fig. 48) Grillage members must be designed to withstand the total wet operating weight of the tower and attendant piping, as well as the dead loads contributed by stairways, catwalks, etc. It must also accept transient loads attributable to wind, earthquake, and maintenance traffic. Grillage members must be level,

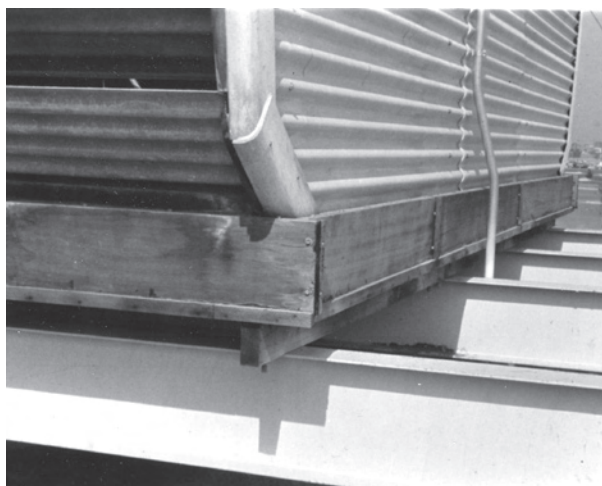

Figure 48 — Steel grillage supporting tower equipped with wood cold water collection basin.

and of sufficient strength to preclude excess deflection under load.

In designing the grillage, the possibility of future extension of the tower should be considered as a means of minimizing future cost impact.

3. **Basin Depth:** As indicated previously, wood, fiberglass and steel basins are of relatively shallow construction, typically 14" to 20" deep. Although greater depths are possible, they are seldom required or recommended. Sufficient freeboard above the operating water level is included to accommodate the normal amount of transient water that collects in the basin at shutdown.

Greater design flexibility is afforded with the concrete basins typically utilized for larger towers (Fig. 44), and adaptable for smaller towers. Once the load points are accommodated at the proper elevation, the basin floor (slab) may be as far below the top of the basin wall (curb) as required to satisfy design criteria. The basin **must** be deep enough to provide sufficient hydraulic head for proper water flow into the sump(s), and to accept the transient water and potential backflow at pump shutdown. Beyond this, the basin **may** be made deep enough to hold a reserve in case of interrupted make-up water supply; to stabilize water temperatures under highly variable loads; or to act as a reservoir to supply the plant fire protection system.

"Dry basins" are minimum depth basin which drain by gravity into adjacent flumes, vessels, collection ponds, or streams. They are so designated because they are intended to drain completely upon pump shutdown. Typical applications of this principle are the "indoor tank" (Fig. 135), and the "helper" tower. (Fig. 49)(Sect. V-L) Sufficiently low water levels in dry-basin towers may necessitate air seals to prevent the reduction in tower performance associated with air by-passing beneath the fill.

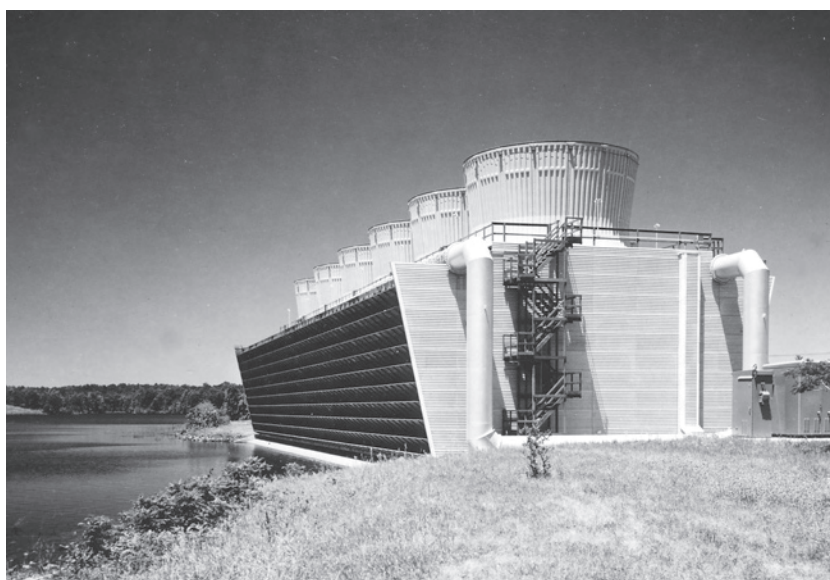

Figure 49 — Water from the basin of this tower returns directly to the lake.



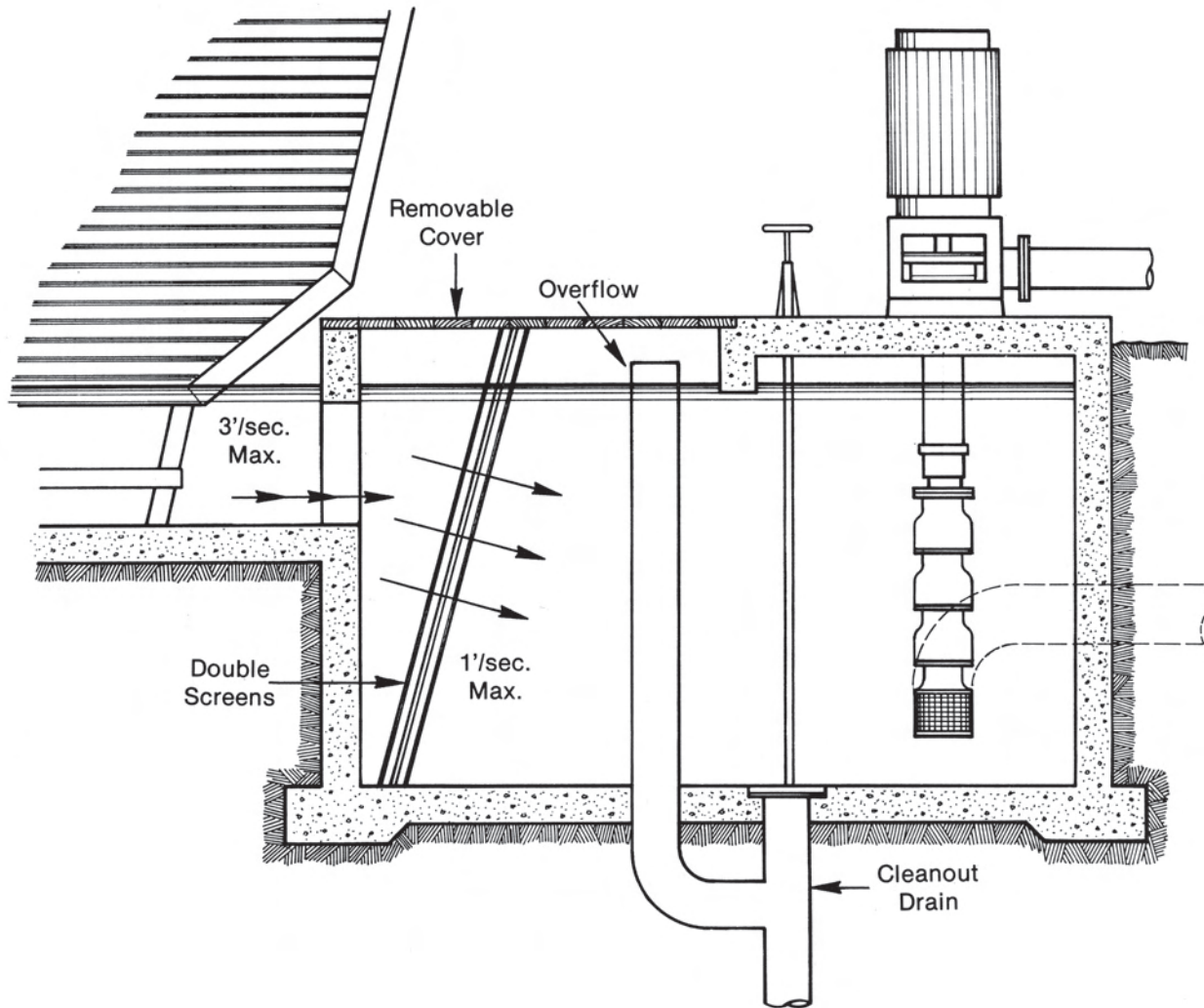

Figure 50 — Typical cross-section of concrete sump pit.

4. **Basin Sumps:** Sumps for towers with wood or steel basins are normally designed and furnished by the manufacturer. (Fig. 45) Concrete sumps (Fig. 50), provided by the purchaser, should be designed for water entrance velocities of less than 3'/second, and should be of sufficient depth to satisfy pump suction head requirements. Screens are usually vertical, of  $\frac{1}{2}$ " square mesh, sized for 1'/second net velocity through the open area of the screen, and held in place by channels imbedded in the sump walls to allow for easy removal. Screens may be installed in duplicate to permit cleaning during continued operation.
5. **Basin Cleaning Facilities:** Because it is an area of relatively low flow velocity, any water borne or borne particulates entering the circulating water system will tend to settle in the basin, where the resultant silt can be either periodically or continuously removed from the system. Periodic sludge removal usually takes place during normal shutdown intervals. Where towers are expected to

operate continuously, strategically located basin partitions can permit partial shutdown for sectional cleaning and maintenance.

Where possible, large capacity cleanout drains (Fig. 50) should be provided. Concrete basin floors should slope toward the sumps or drains at a rate of 1' per 100', to permit flushing of the sediment. Where drains cannot be provided, basins should slope toward a cleanout sump from which sludge can be pumped, or removed manually.

Side-stream filtration (Sect. VI-E) has been found to be an effective means of maintaining suspended solids at acceptable levels in the circulating water system, and of reducing the costs associated with periodic silt removal. For most effective filtration, discharge flow from the filter should be returned to areas of low velocity in the basin in order to help maintain particulate suspension.

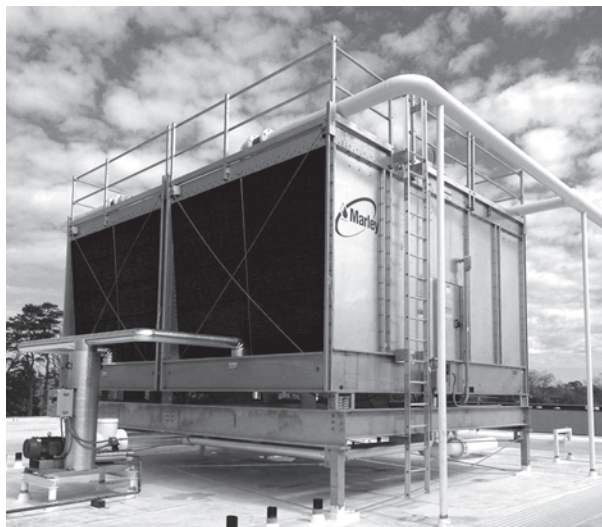

Figure 51 — Factory-assembled towers of stainless steel construction are utilized in corrosive areas.

### C. TOWER FRAMEWORK

The most commonly used materials for the framework of field-erected towers are pultruded fiberglass, wood, and concrete, with steel utilized infrequently to conform to a local building code, or to satisfy a specific preference. Factory-assembled towers predominate in steel construction, with stainless steel increasingly utilized in locations (or for processes) that tend to promote corrosion. (Fig. 51)

A uniform wind load design of 30 pounds per square foot is standard, with higher values either

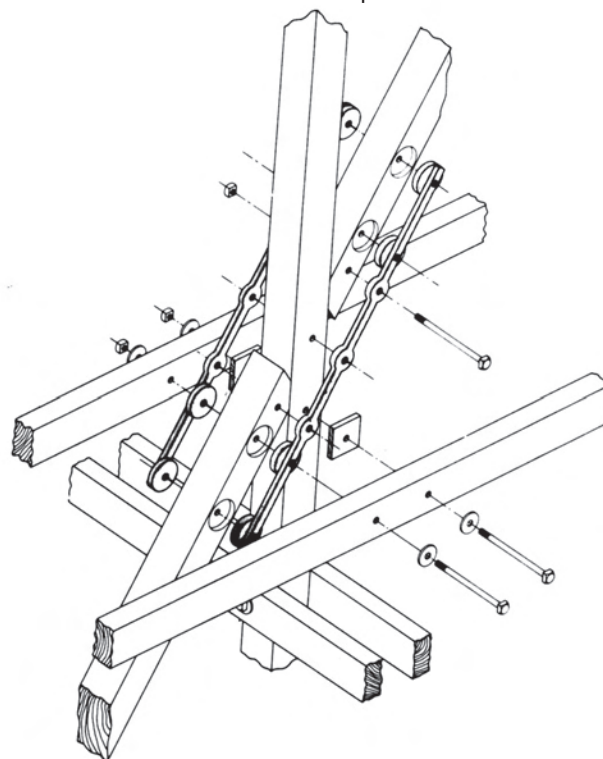
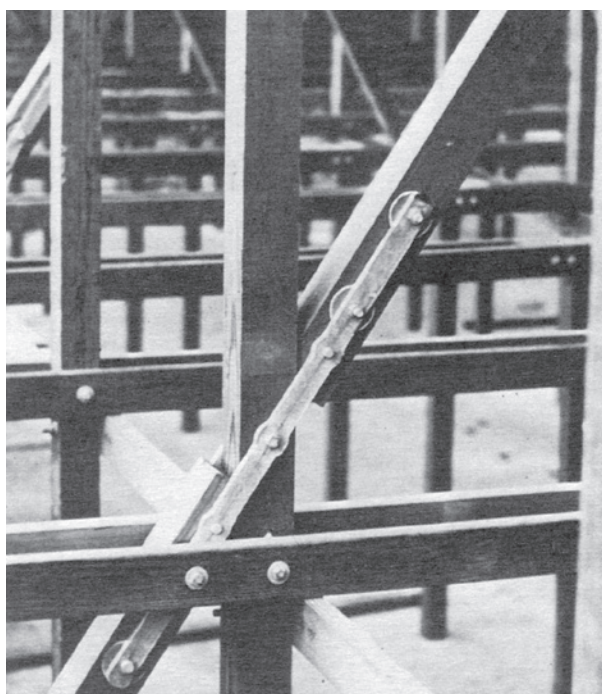

Figure 52 — Framework and joint detail in a well-designed cooling tower of wood construction.

dictated or advisable in some areas. Earthquake loads, if applicable, are in accordance with zones defined in the Uniform Building Code of the International Conference of Building Officials. Design stress values for wood members and fasteners are based on the National Design Specification of the National Forest Products Association. Steel members are governed by the American Institute of Steel Construction manual, and concrete is based on Building Code Requirements for Reinforced Concrete of the American Concrete Institute. Fir lumber grades conform to Standard 16 of the West Coast Lumber Inspection Bureau, latest revision. Redwood lumber grades conform to Standard Specification for Grades of California Redwood Lumber of the California Redwood Association, latest revision.

In large wood towers, the columns are normally spaced on 4' x 8' or 6' x 6' centers. (Fig. 44) Fiberglass towers are typically on 6' x 6' centers. These bay sizes have evolved over the years and have proved best to properly support the fill, drift eliminators, and louver modules, as well as to keep lumber sizes to those that are readily available.

Diagonal bracing in the plane of the columns is usually of column size (Fig. 52), with loads transmitted through fiber reinforced plastic structural connectors at the joints. Horizontal girts in the transverse and longitudinal directions carry the fill modules, and keep the unbraced column lengths to short vertical spans. In order to achieve a determinant definition of lateral bracing of the columns against buckling, transverse and longitudinal girt lines should be at the same plane.

SECTION II

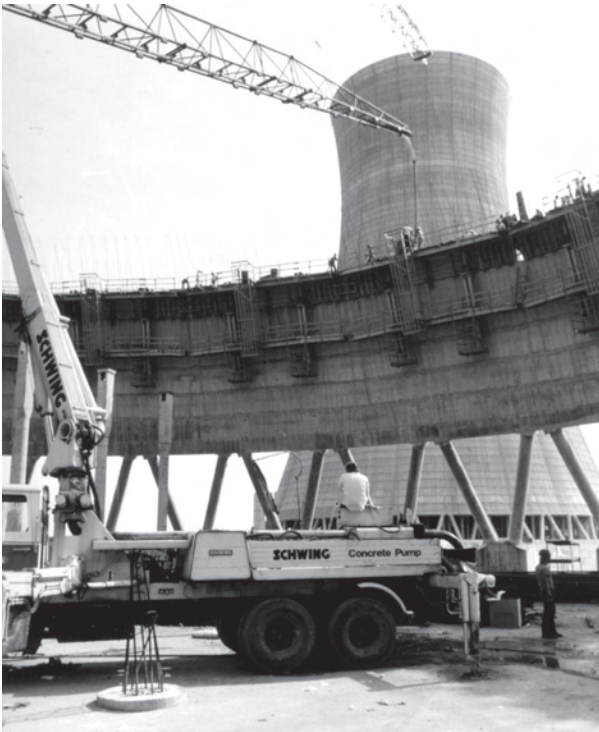

Figure 53

Concrete tower structural members (Fig. 46) may be a combination of precast and poured-in-place construction with design varying according to applicable loads and tower configuration. Main columns for support of fans and large distribution flumes may be formed by pumping concrete. This technology also permits high-lift pumping of concrete for hyperbolic shell construction. (Fig. 53)

Fill and distribution system support may utilize a column and beam system, or stacked panel trusses. (Fig. 54)

Applicable reinforcement, prestressing, or post-tensioning is utilized as required by design considerations. (Fig. 55)

Precast double-tee sections are frequently used for such elements as fan decks, or the floors of flumes and distribution basins. (Figs. 56a & 56b)

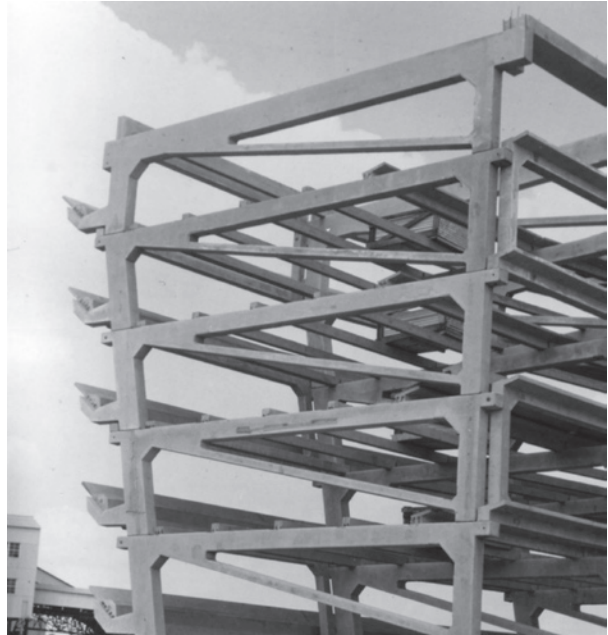

Figure 54



Figure 55



Figure 56a



Figure 56b

## D. WATER DISTRIBUTION SYSTEM

In a general sense, piping and distribution of the water within the envelope of the tower are responsibilities of the tower manufacturer. Site piping, as well as attendant risers, valves and controls, which occur outside the confines of the cooling tower are provided and installed by others.

Magnitude and routing of the circulating water lines between the heat source and the tower location are usually dictated by type of tower, topography and site layout. (Sect. I-E-7-(d), Fig. 39) Lines may be buried to minimize problems of thrust loading, thermal expansion and freezing; or elevated to minimize cost of installation and repair. In either case, the risers to the tower inlet must be externally supported, independent of the tower structure and piping.

1. **Types and Arrangements:** Crossflow tower configuration (Fig. 56b) permits the use of a gravity-flow distribution system wherein the supply water is elevated to hot water distribution basins above the fill, from which it flows over the fill (by gravity) through metering orifices located in the distribution basin floor.

Conversely, counterflow configuration (Fig. 57) normally necessitates the use of a pressure-type system of closed pipe and spray nozzles.

Gravity systems are readily inspected, cleaned and maintained, and easily balanced; but contribute negligibly to overall heat transfer, tend to require a somewhat higher pump head in larger towers, and may promote the formation of algae unless the open basins are covered. Pressure



Figure 57 — Counterflow distribution system in operation

spray systems are more susceptible to clogging and more difficult to balance, clean, maintain and replace; but contribute significantly to overall heat transfer, tend toward lower pump heads in towers of larger size, and are less conducive to algae growth.

A typical supply piping arrangement, applicable to multi-cell crossflow or counterflow towers, positions the supply line adjacent to the long side of the tower and running the full length. (Fig. 58) Vertical risers (one per cell) connect the supply line to the manufacturer's inlet connections at the elevation of the tower's distribution system. Valves are usually installed in these risers to enable individual cells to be taken out of service.



Figure 58 — Four-cell tower with individual side risers.

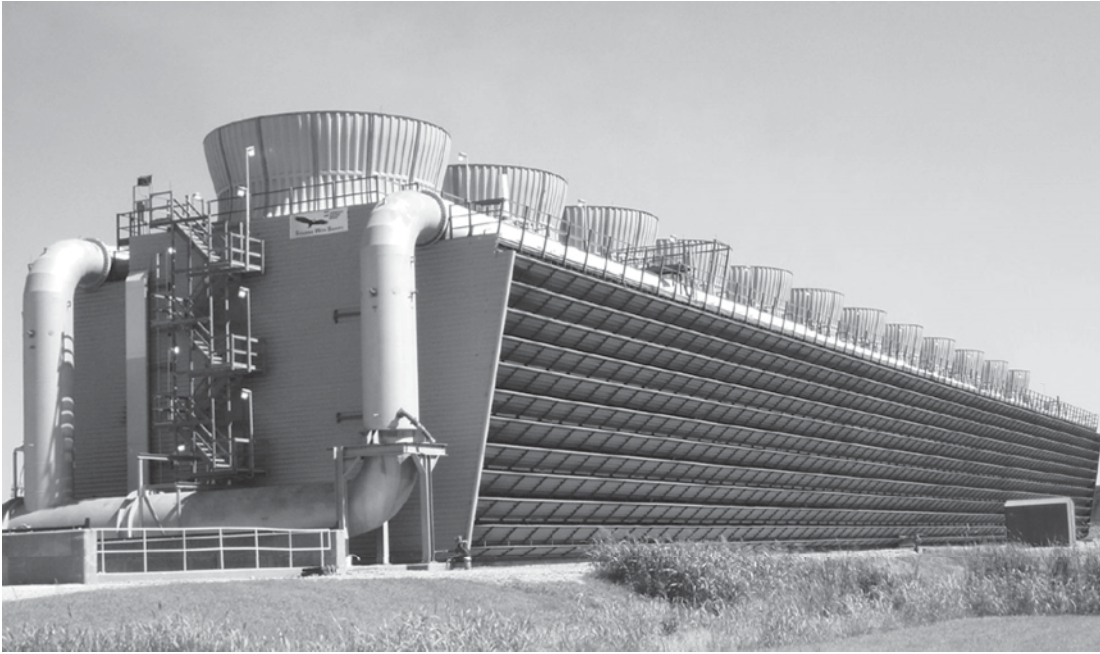

Figure 59 — Double end inlets allow large water flows without the necessity for piping of unreasonable size.

The crossflow design permits many piping variations that can be adapted to multi-cell towers. Two risers at one end of the tower (Fig. 59), connecting to the manufacturer's header piping, is one method used for large circulating water rates.

Where flow rates permit, a single riser at the end of the tower (Fig. 60), or somewhere along

the louvered face, can be utilized, connecting to the manufacturer's manifold header at the top of the tower. In either case, the manufacturer's header piping runs the full length of the tower, serving each half-cell distribution basin through flow-control valves, and crossover piping as necessary. (Fig. 61)

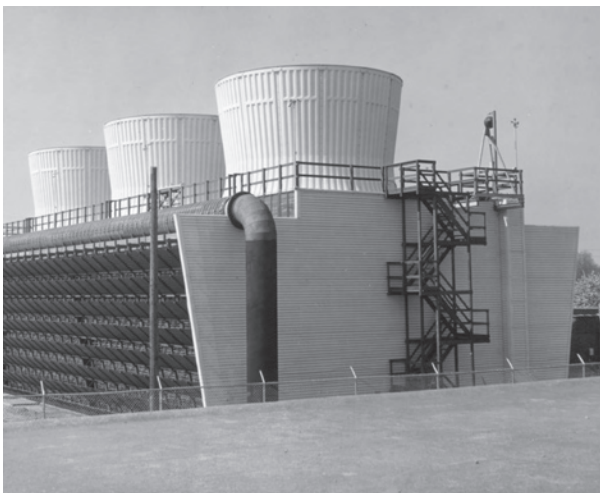

Figure 60 — Lesser flows can be handled by single riser and header.

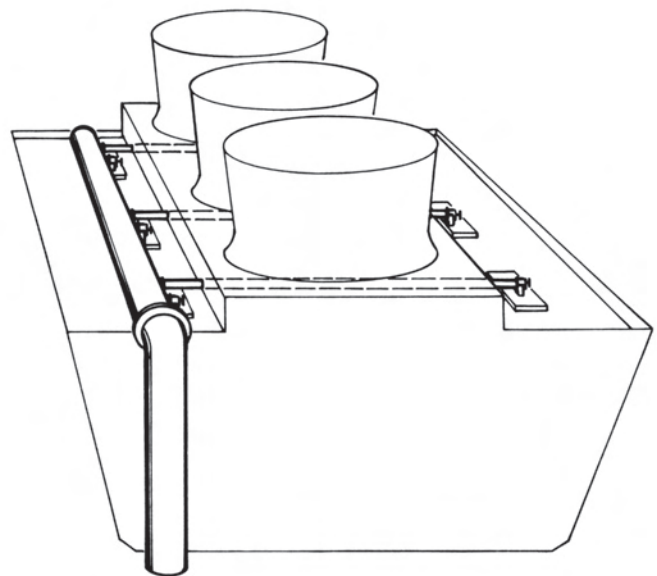

Figure 61 — Single header supplies near-side basin through valves. Far-side distribution basin supplied via crossover piping and valves.



Figure 62 — Distribution system of an operating round crossflow tower.

Concrete crossflow round towers (Fig. 62) typically utilize an open concrete flume, fed by one or more concrete internal risers, for primary distribution of the hot water. Radial flow from the flume into the open distribution basin is through adjustable weirs or gates. Proper placement of stop logs in the flume permits the opportunity for major maintenance of a sector of an operating tower, should the need arise.

Concrete counterflow round or octagonal towers (Fig. 63) also make use of one or more internal concrete risers feeding an elevated system of closed flumes or conduits (usually of concrete) which, in turn, supply an array of branch piping and closely spaced nozzles to achieve uniform water distribution over the fill.

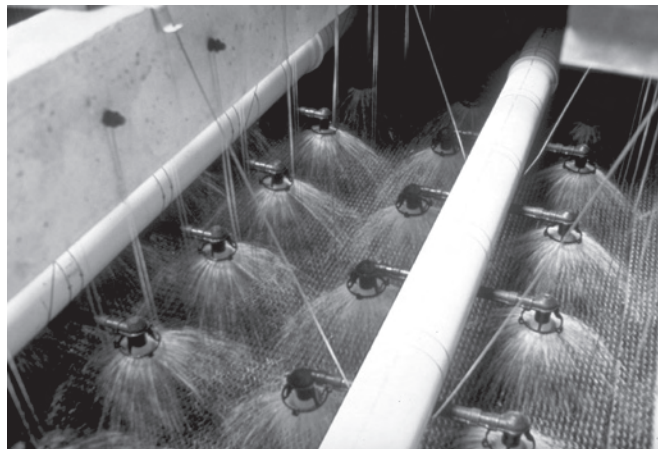

Figure 63 — Typical counterflow tower distribution system.

2. **Distribution System Materials:** Distribution systems are subjected to a combination of hot water and maximum oxygenation. Therefore, the materials utilized should be highly resistant to both corrosion and erosion. Historically proven materials are hot-dip galvanized steel, cast iron, and redwood stave pipe. Because of the relatively low pressures to which cooling tower piping is subjected, the use of various types of plastic pipe (Fig. 64) and nozzles has also become a mark of quality construction. Except for relatively small diameters, the plastic pipe utilized is usually fiber reinforced. Precast and prestressed concrete pipe and flumes are also utilized on concrete towers.

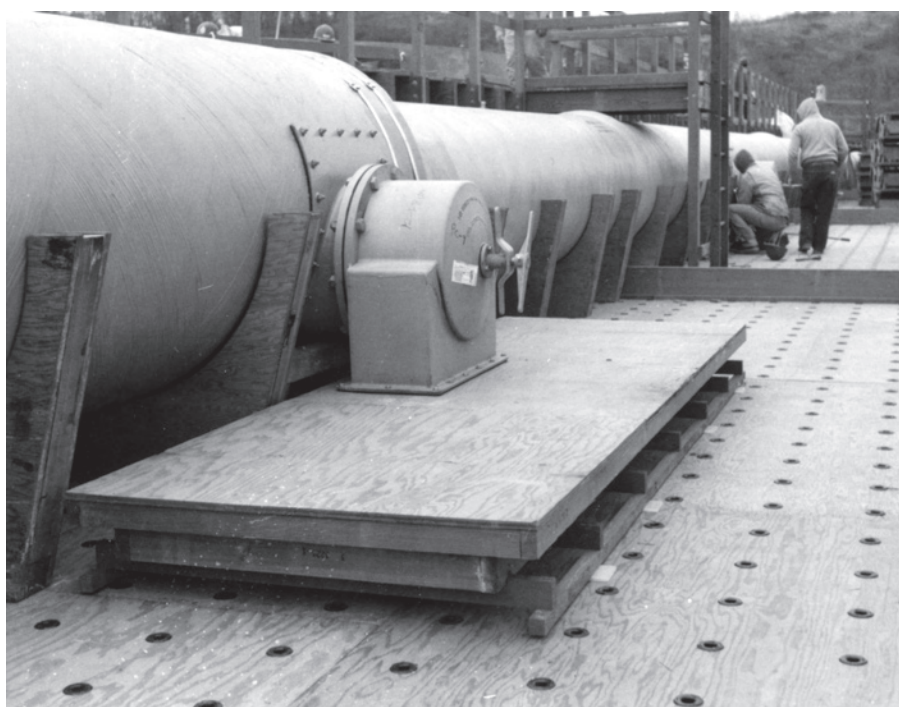

Figure 64 — Large plastic distribution header.

3. **Riser Sway Braces:** Wind and/or earthquake considerations will occasionally influence specifying engineers to call for sway braces which tie the upper end of a foundation-cantilevered riser to the larger tower structure, which is assumed by the specification writer to have the greater rigidity. This is *not* good practice when the riser is of a material having a high modulus of elasticity, such as steel. The cooling tower structure will react quite differently from the riser under an imposed load condition. For example, under earthquake acceleration the riser will respond at high frequency and low amplitude, whereas the tower structure (of lower modulus material) will respond at lower frequency and greater amplitude. The result is that any connection between the two will be attempting to transmit the seismic response of the tower into the more rigid risers, and damage to the endwall framing or the piping connections may follow.

A riser brace capable of transmitting the high loads generated by a differential response is a costly auxiliary structure which imposes significant loadings at anchorage points in the cold water basin, and its utilization in such cases should be avoided. Properly designed cooling tower header piping will accommodate typical horizontal and vertical movement without distress, and the flanged joint between the riser and the distribution header should never be considered as a riser support. In cases of doubt, an expansion joint or flexible coupling should be provided between the riser and header to allow relative movement to occur.

Risers of FRP plastic pipe have a modulus of elasticity close to that of the tower structure and will experience similar seismic response. Therefore, destructive transfer of opposed loads is unlikely, and the flexibility of the FRP pipe riser may require lateral support at the top. In such cases, a riser sway brace may be a desirable solution.

4. **Ancillary Systems:** Provision must be made for make-up, overflow and blowdown, and should be made for by-pass. Since proper by-pass utilization is covered more fully in Sections I-H and V-F, suffice it here to say that the location of the by-pass should be in accordance with the manufacturer's recommendations to prevent damage to the structure or the fill.

The amount of make-up water required consists of the total water losses accrued through evaporation (Sect. I-D), drift (Sect. II-I), blowdown (Sect. I-G-1) and system leakage. On relatively small towers, make-up is controlled by a mechanical float valve responding to the basin water level. (Fig. 65) Float switches or electric probe systems are normally used on larger towers to open and close a make-up valve, or to start and stop a make-up pump. (Fig. 66) These may be located in a stilling chamber designed to suppress the effect of normal wave action in

the basin. Make-up lines from potable sources are usually brought to the cold water basin, installed with their point of discharge downturned, and sufficiently above the basin water level to preclude contamination of the supply by the circulating water. Non-potable water, of course, may be connected for injection of the make-up supply at any point in the water circuit.

Overflow lines (Fig. 50) may be sized large enough to facilitate flush-out cleaning of a sump, but *must* be large enough to handle full make-up flow in case that device malfunctions.

Blowdown lines should be sized to handle the maximum anticipated amount of water to be wasted. (Sect. I-G-1) Although blowdown can be taken from the cold water basin, it is usually easier to control if taken from the pressure-side (i.e. the inlet riser) piping.



Figure 65 — Float-operated mechanical make-up valve.

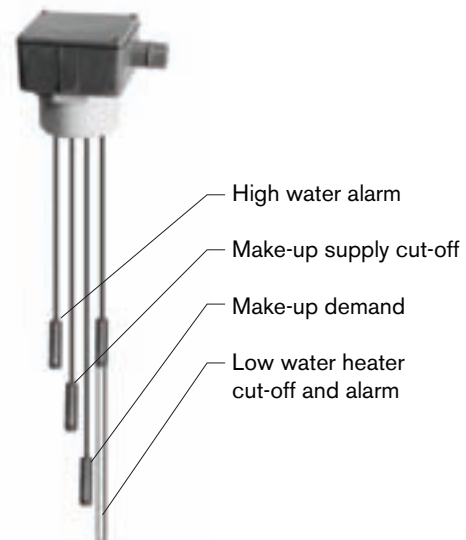

Figure 66 — Electric probes can be used to actuate various systems.

## E. FAN DECK

The fan deck is considered a part of the tower structure, acting as a diaphragm for transmitting dead and live loads to the tower framing. It also provides a platform for the support of the fan cylinders, as well as an accessway to the mechanical equipment and water distribution systems.

Fan deck materials are customarily compatible with the tower framework. Wood towers normally utilize tongue-and-groove fir plywood; pultruded FRP on pultruded FRP towers; galvanized steel on steel towers; and prestressed double-tee sections on concrete towers.

Uniform live loading design on larger towers is normally 60 pounds per square foot, reducing to 40 pounds per square foot on the smaller towers.

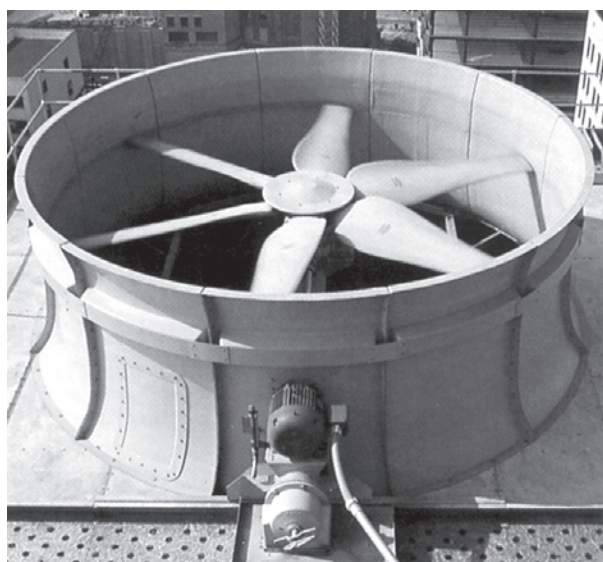

Figure 67 — Typical fiber-reinforced plastic fan cylinder.

## F. FAN CYLINDERS

Considerable thought, calculation, modeling, and testing goes into the design and construction of a fan cylinder because it so directly affects the proper flow of air through the tower. (Sect. III-B) Fan efficiencies can be severely reduced by a poorly designed fan cylinder, or significantly enhanced by a well-designed one.

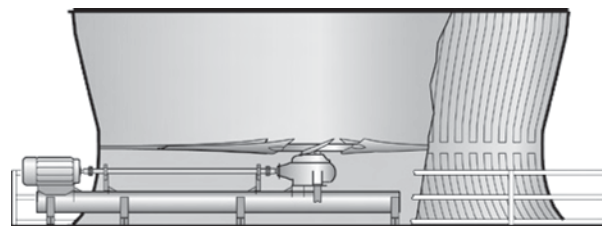

Figure 68 — Cut-away view of velocity recovery type fan cylinder.

The essence of a well-designed fan cylinder (Fig. 67) incorporates: an eased inlet to promote smooth flow of air to the fan; minimum fan blade tip clearance; a smooth profile below and above the fan; sufficient structural strength to maintain a stable plan and profile; and either sufficient height to protect operating personnel, or a removable mesh guard, structurally reinforced

All of these physical requirements have practical limitations, generally controlled by the materials of construction. Fiber-reinforced plastic, because of its formability, strength, relatively light weight, stability, and resistance to water and weathering, is the preferred material for this application. Cylinders are formed over molds which accurately control contour and dimensions, resulting in a fan cylinder that approaches ideal air movement, coupled with minimum noise. Good fan cylinders are also constructed of wood or steel. However, shape factors usually result in lower fan efficiencies.

Fan cylinders of an extended height (sometimes called "fan stacks") promote discharge of the saturated air stream at higher elevations, minimizing the effects of recirculation and interference. (Sect. I-E-5 & 6) One type of fan stack is in the form of a flared diffuser (Fig. 68) that provides a gradual increase in cross-sectional area beyond the fan with a resultant decrease in leaving air velocity. This effectively converts velocity pressure to static pressure, resulting in a significant increase in air delivery over what could be accomplished with a straight cylinder at the same fan horsepower. These velocity-recovery cylinders are particularly applicable to large industrial towers. (Figs. 58 & 59)





Figure 69 — Mechanical equipment mounted on torque tube, before installation of fan blades. Note retaining guards for driveshaft.

### G. MECHANICAL EQUIPMENT SUPPORTS

The framework of a cooling tower is not totally inflexible, even on concrete towers which utilize structural members of relatively massive cross section. Considering the tremendous torsional forces encountered in the operation of large fans at high horsepower, it becomes apparent that some means of assuring a constant plane-relationship throughout the motor-gear-reducer-fan drive train *must* be provided in order to maintain proper alignment of the mechanical equipment.

For smaller fan units, unitized steel weldments of structural cross section serve well. However, the forces imposed by the operation of larger fans dictate the use of unitized supports of greater sophistication. These usually consist of large, heavy-wall torque tubes welded to outriggers of structural steel. (Fig. 69)

Customary material for these unitized supports is carbon steel, hot-dip galvanized after fabrication, with stainless steel construction available at significant additional cost. The combination of heavy construction, plus galvanization, generally makes stainless steel construction unnecessary.

### H. FILL (Heat Transfer Surface)

The single most important component of a cooling tower is the fill. Its ability to promote both the maximum contact surface and the maximum contact time between air and water determines the efficiency of the tower. And, it must promote this air-water contact while imposing the least possible restriction to air flow. Maximum research and development effort goes into the design and application of various types of fill, and technological advances are cause for celebration.

Most reputable cooling tower manufacturers design and produce fill specifically suited to their distribution, fan, and support systems; developing all in concert to avoid the performance-degrading effects of a misapplied distribution system, or an air-impeding support structure. Those who are less meticulous will adapt commercially available components (fill, fans, driveshafts, distribution systems, etc.) into the shape and appearance of a cooling tower, relying upon the laboratory ratings of these components to remain dependable in less-than-laboratory conditions.

The two basic fill classifications are *splash type* (Fig. 70) and *film type*. (Fig. 71) Although either

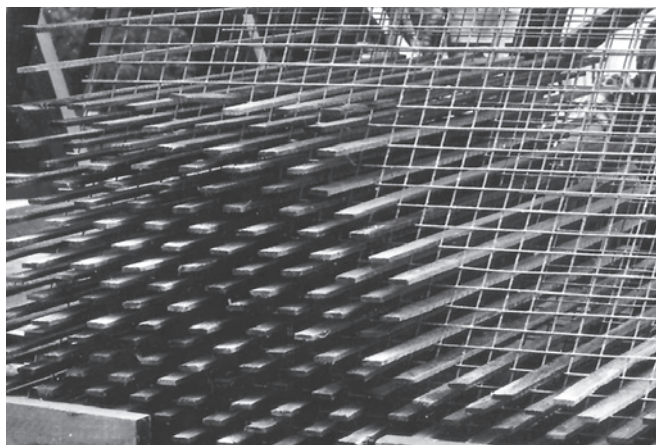

Figure 70a — Splash type fill: wood splash bars.

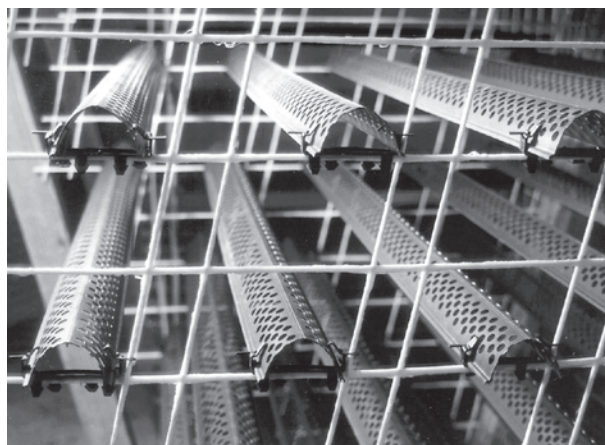

Figure 70b — Splash type fill: plastic splash bars.

type can be applied in crossflow or counterflow configuration, counterflow towers are tending toward almost exclusive use of the film fills. Crossflow towers, on the other hand, make use of either type with equal facility, occasionally in concert.

**Splash type fill** breaks up the water, and interrupts its vertical progress, by causing it to cascade through successive offset levels of parallel splash bars. Maximum exposure of the water surface to the passing air is thus obtained by repeatedly arresting the water's fall and splashing it into small droplets, as well as by wetting the surface of the individual splash bars. (Fig. 17)

Splash fill is characterized by reduced air pressure losses, and is not conducive to clogging. However, it is very sensitive to inadequate support. The splash bars **must** remain horizontal. If sagging occurs, the water and air will "channel" through the fill in separate flow paths, and thermal performance will be severely impaired. Also, if the tower is not level, water will gravitate to the low ends of the splash bars and produce this channeling effect.

Long term performance reliability requires that the splash bars be supported on close centers, and that the support materials be as inert as practicable. Of the various support mechanisms presently in use, fiber reinforced plastic grid hangers are recognized as having the longest history of success, with PVC coated wire grids also enjoying considerable use. In utilizing coated carbon steel grids, however, care must be exercised to assure that the splash bars will not abrade the coating, exposing the wire to corrosion.

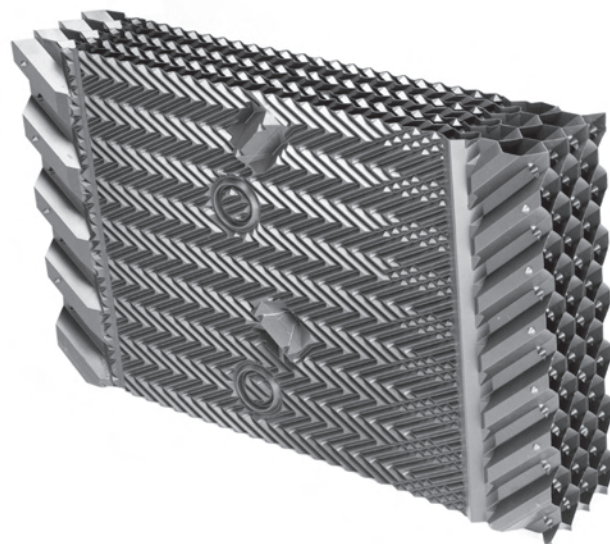

Figure 71 — Film type fill.

Treated wood lath (primarily Douglas Fir) predominated for many years as splash bar material, and continues to be extensively used because of its strength, durability, availability, and relatively low cost. (Fig. 70a) Currently, however, plastics have gained predominance. They may be injection moldings of polypropylene, or similar materials which can be compounded for resistance to fire; or they may be extrusions of PVC (Fig. 70b), which inherently has a low flame spread rate. Stainless steel or aluminum splash bars are occasionally used in steel framed towers where totally fireproof construction may be mandatory.

**Film type fill** causes the water to spread into a thin film, flowing over large vertical areas, to pro-

mote maximum exposure to the air flow. (Fig. 71) It has the capability to provide more effective cooling capacity within the same amount of space, but is extremely sensitive to poor water distribution, as well as the air blockage and turbulence that a poorly designed support system can perpetuate. The overall tower design must assure uniform air and water flow throughout the entire fill area. Uniform spacing of the fill sheets is also of prime importance due to the tendency of air to take the path of least resistance.

Because the fill sheets are closely spaced in the highest performance fill designs, ***the use of film fill should be avoided in situations where the circulating water can become contaminated with debris.*** A diverse range of clog resistant fill designs are available, with a progressively lower performance capability increasing with fouling resistance in general.

Film fill can be made of any material that is capable of being fabricated or molded into shaped sheets, with a surface formed as required by the design to direct the flow of air and water. Because PVC is inert to most chemical attack, has good strength characteristics, is light in weight, has a low flame spread rate, and can be easily formed to the shape required, it is currently the most popular material.

## I. DRIFT ELIMINATORS

As a by-product of the cooling tower having promoted the most intimate contact between water and air in the fill, water droplets become entrained in the leaving air stream. Collectively, these solid water droplets are called "drift" and are not to be confused with the pure water vapor with which the effluent air stream is saturated, nor with any droplets formed by condensation of that vapor. The composition and quality of drift is that of the circulating water flowing through the tower. Its potential for nuisance, in the spotting of cars, windows and buildings, is considerable. With the tower located upwind of power lines, substations, and other critical areas, its potential as an operating hazard can be significant.

Drift eliminators remove entrained water from the discharge air by causing it to make sudden changes in direction. The resulting centrifugal force separates the drops of water from the air, depositing them on the eliminator surface, from which they flow back into the tower. Although designers strive to avoid excess pressure losses in the movement of air through the eliminators, a certain amount of pressure differential is beneficial because it assists in promoting uniform air flow through the tower fill.

Eliminators are normally classified by the number of directional changes or "passes", with an increase in the number of passes usually accompanied by an increase in pressure drop. They may consist of two or more passes of spaced slats positioned in frames (Fig. 72) or may be molded into a cellular configuration with labyrinth passages. (Fig. 73) Some towers

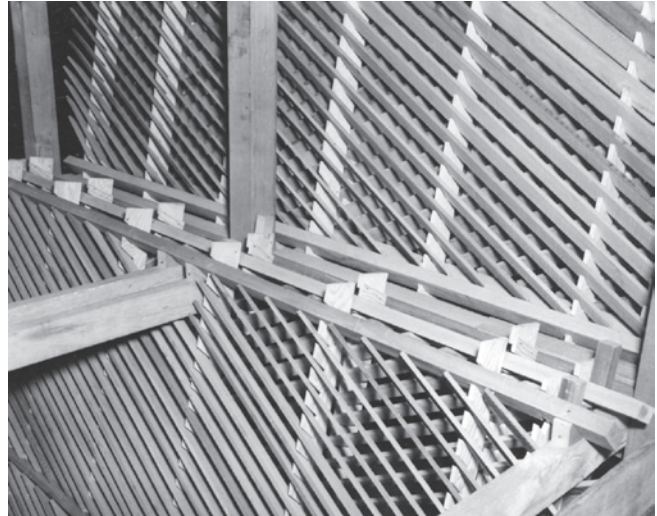

Figure 72 — Two-pass "herringbone" drift eliminators of wood construction.

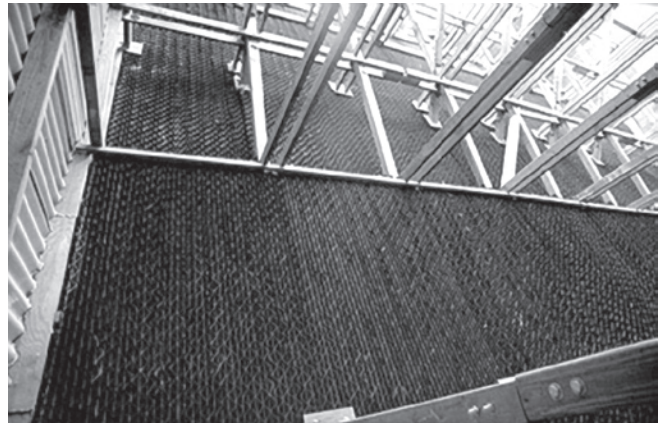

Figure 73 — Three-pass "cellular" drift eliminators of PVC construction.



Figure 74 — Drift eliminators molded integrally with fill sheets.

that utilize film type fill have drift eliminators molded integrally with the fill sheets. (Fig. 74)

Since drift eliminators should be as corrosion resistant as the fill, materials acceptable for fill are usually incorporated into eliminator design, with treated wood and various plastics (predominantly PVC) being most widely used.

In the decade of the 1970s, concern for the possible environmental impact of drift from cooling towers stimulated considerable research and development in that field and, as might be expected, significant advances in drift eliminator technology occurred. Currently, the anticipated drift levels in smaller, more compact towers will seldom exceed 0.008% of the circulating water rate. In larger towers, affording more room and opportunity for drift-limiting techniques, drift levels will normally be in the region of 0.001%, with levels of 0.0005% attainable. (Sect. V-H)

## J. CASING

A cooling tower casing acts to contain water within the tower, provide an air plenum for the fan, and transmit wind loads to the tower framework. It must have diaphragm strength, be watertight and corrosion resistant, and have fire retardant qualities. It must also resist weathering, and should present a pleasing appearance.

Currently, wood or steel framed, field-erected towers are similarly cased with fire-retardant fiber-reinforced polyester corrugated panels, overlapped and sealed to prevent leakage. Factory-assembled steel towers (Fig. 11) utilize galvanized steel panels, and concrete towers are cased with precast concrete panels.

If required for appearance purposes, the casing can be extended to the height of the handrail. (Fig. 75)



Figure 75 — Casing extended to handrail height.

## K. LOUVERS

Every well-designed crossflow tower is equipped with inlet louvers, whereas counterflow towers are only occasionally required to have louvers. Their purpose is to retain circulating water within the confines of the tower, as well as to equalize air flow into the fill. They must be capable of supporting snow and ice loads and, properly designed, will contribute to good operation in cold weather by retaining the increase in water flow adjacent to the air inlets that is so necessary for ice control. (Sect. I-H-2)

Closely spaced, steeply sloped louvers afford maximum water containment, but are the antithesis of free air flow, and can contribute to icing problems. Increasing the horizontal depth (width) of the louvers significantly increases their cost, but it permits wider spacing, lesser slope and improved horizontal overlap, and is the design direction taken by most reputable manufacturers. (Fig. 49)

The most-utilized louver materials are corrugated fire-retardant fiber reinforced polyester and treated Douglas Fir plywood on field-erected towers, galvanized steel on factory-assembled steel towers, and precast, prestressed concrete on concrete towers.

The evolution of louver design began in the early era of splash type fill, more than 70 years ago, at which time their primary function was to control the multitude of random water droplets produced by the splashing action. Because of the width and spacing necessary to accomplish this magnitude of water recovery, louvers became a highly visible, accented part of the cooling tower's appearance, as evidenced by Figure 49.

With the advent of acceptable film type fills, with their inherently better water management characteristics, louver design was reassessed. Ultimately, the highly visible type louvers disappeared from certain



Figure 76 — Crossflow air inlet face. (Note apparent lack of louvers.)

cooling towers specifically designed for operation only with film type fill. (Fig. 76) However, as can be seen in Figure 77, the louvers remain – they have merely become an integral part of the leading edge of the fill sheets.

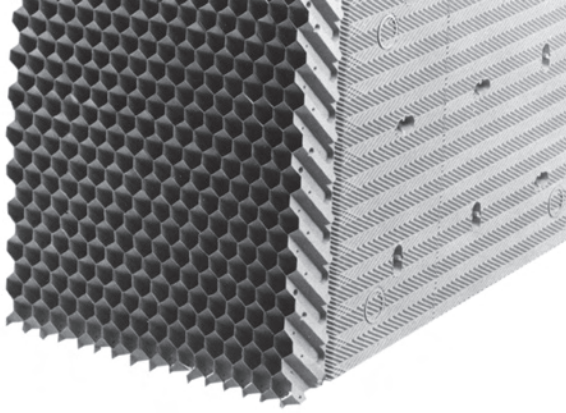

Figure 77 — Air inlet louvers molded integrally with fill sheets.

One should not anticipate from this that louvers are obsolescent. Splash type fill is still widely used, especially in contaminated water service, and is expected to remain so for the foreseeable future. Furthermore, the use of film fill towers without external louvers in certain operating conditions, such as excessively high water loadings, is ill advised.

#### L. ACCESS AND SAFETY CONSIDERATIONS

Access to various components of a cooling tower is usually influenced by the manufacturer's recommendations, whereas safety considerations are the result of intelligent interpretation of the guidelines promulgated by the Occupational Safety and Health Administration (OSHA). Both aspects take the user's unique requirements into consideration to the greatest possible degree.

On towers of relatively low height (Figs. 5 & 11), where maintenance access may be gained by the use of mobile platforms or portable ladders, fixed access ladders and safety handrails are not mandatory. This also applies to small atmospheric (Fig. 2) and forced draft towers (Fig. 4) where no elevation of the tower is specifically decked as a working platform.

Towers of larger dimension normally require some form of permanently fixed access to the level(s) of normal maintenance. On hyperbolic towers (Fig. 3), access usually terminates at the water distribution system level, except where the existence of aircraft warning lights dictates higher access. Standard equipment on mechanical draft towers of intermediate size (Fig. 78) typically consists of a fixed vertical ladder, which may optionally be enclosed within a protective safety cage device, and *must* be so enclosed where vertical heights exceed OSHA limi-

tations. Larger mechanical draft towers (Fig. 49) are customarily supplied with wide access stairways, constructed of a material compatible with the cooling tower structure. In either case, sturdy handrails, kneerails, and toeboards must be provided around the periphery of the access level.

On relatively long cooling towers, it is wise to equip each end of the tower with a stairway or ladder. Indeed, some localities require this for conformance with fire safety regulations.

Certain areas of a cooling tower require occasional maintenance, but are relatively enclosed. Counterflow towers should be equipped with an access door in each cell to gain access to the water distribution system. Usually, these doors are located in the fan deck floor, complete with vertical ladders down to the distribution level.

Double-flow (crossflow) towers (Fig. 78) should be equipped with access doors, located just above the cold water basin level, at each end of the tower and in each successive cell partition wall to permit access to the basin, as well as to encourage inspection of the tower's structural internals. Where the tower is mounted over a deep basin, an interior walkway running the full length of the tower connecting these access doors must be included. (On basins less than 4' deep, this walkway is optional.) Single-flow towers (Fig. 10) should have a basin level access door in the backwall casing of each cell.

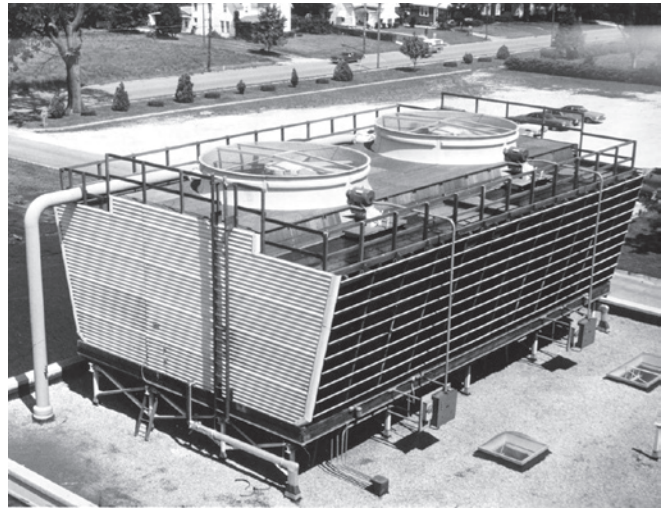

Figure 78 — Note access ladders, handrails and fan guards.

## Mechanical Components

### A. GENERAL

Cooling tower mechanical equipment is required to operate within a highly corrosive, moisture-laden atmosphere that is unique to the cooling tower industry, and the historical failure rate of commercially available components caused reputable tower manufacturers to undertake their own production of specific components some years ago. Currently, the low failure rate of manufacturer-produced components reinforces that decision. Purchasers also benefit from the advantage of single-source responsibility for warranty, and replacement parts.

Exclusive of motors, which are covered in Section IV, the mechanical components basic to the operation of the cooling tower are fans, speed reducers, drive shafts, and water flow control valves. Auxiliary devices, of a mechanical nature, are discussed in Section VI.

### B. FANS

Cooling tower fans must move large volumes of air efficiently, and with minimum vibration. The materials of manufacture must not only be compatible with their design, but must also be capable of withstanding the corrosive effects of the environment in which the fans are required to operate. Their importance to the mechanical draft cooling tower's ability to perform is reflected in the fact that fans of improved efficiency and reliability are the object of continuous development.

1. **Propeller Fans:** Propeller type fans predominate in the cooling tower industry because of their ability to move vast quantities of air at the relatively low static pressures encountered. They are comparatively inexpensive, may be used on any size tower, and can develop high overall efficiencies when "system designed" to complement a specific tower structure – fill – fan cylinder configuration. Most-utilized diameters range from 24 inches to 10 meters (Fig. 79), operating at horsepower from 1/4 to 250+. Although the use of larger fans, at higher power input, is not without precedence, their application naturally tends to be limited by the number of projects of sufficient size to warrant their consideration. Fans 48 inches and larger in diameter are equipped with adjustable pitch blades, enabling the fans to be applied over a wide range of operating horsepower. Thus the fan can be adjusted to deliver the precise required amount of air at the least power consumption.

The rotational speed at which a propeller fan is applied typically varies in inverse proportion to its diameter. The smaller fans turn at relatively high speeds, whereas the larger ones turn somewhat

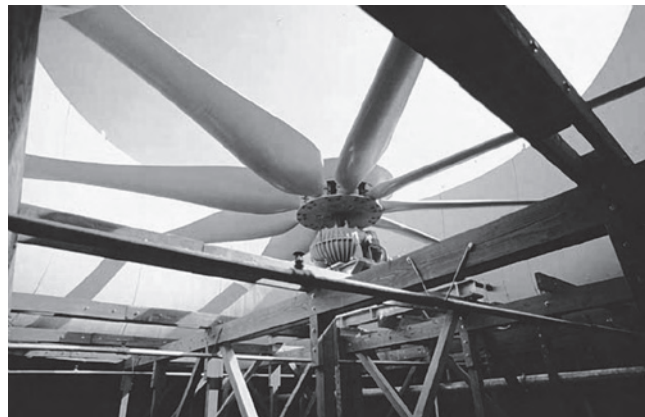

Figure 79 — Typical large diameter fan utilized on cooling towers.

slower. This speed-diameter relationship, however, is by no means a constant one. If it were, the blade tip speed of all cooling tower fans would be equal. The applied rotational speed of propeller fans usually depends upon best ultimate efficiency, and some diameters operate routinely at tip speeds approaching 14,000 feet per minute. However, since higher tip speeds are associated with higher sound levels, it is sometimes necessary to select fans turning at slower speeds to satisfy a critical requirement.

The increased emphasis on reducing cooling tower operating costs has resulted in the use of larger fans to move greater volumes of air more efficiently. Much research has also gone into the development of more efficient blade, hub, and fan cylinder designs. The new generations of fans are light in weight to reduce parasitic energy losses, and have fewer, but wider, blades to reduce aerodynamic drag. Moreover, the characteristics of air flow through the tower, from inlet to discharge, are analyzed and appropriate adjustments to the structure are made to minimize obstructions; fill and distribution systems are designed and arranged to promote maximum uniformity of air and water flow; and drift eliminators are arranged to direct the final pass of air toward the fan. This is recognized as the "systems" approach to fan design, without which the best possible efficiency **cannot** be obtained.

The intent of good propeller fan design is to achieve air velocities across the effective area of the fan, from hub to blade tips, that are as uniform as possible. The most effective way



Figure 80 — Large fan being installed.

to accomplish this is with tapered and twisted blades having an airfoil cross section. (Fig. 80) Historically, cast aluminum alloys have been the classic materials used for production of this blade type. Cast aluminum blades continue to be utilized because of their relatively low cost, good internal vibration damping characteristics, and resistance to corrosion in most cooling tower environments.

Currently, lighter blades of exceptional corrosion resistance are made of fiberglass-reinforced plastic, cast in precision molds. These blades may be solid; formed around a permanent core; or formed hollow by the use of a temporary core. (Fig. 81) In all cases, they have proved to be both efficient and durable.

Fan hubs must be of a material that is structurally compatible with blade weight and loading, and must have good corrosion resistance. Galvanized steel weldments (Fig. 82), gray and ductile



Figure 81 — Hollow-core fan blade.

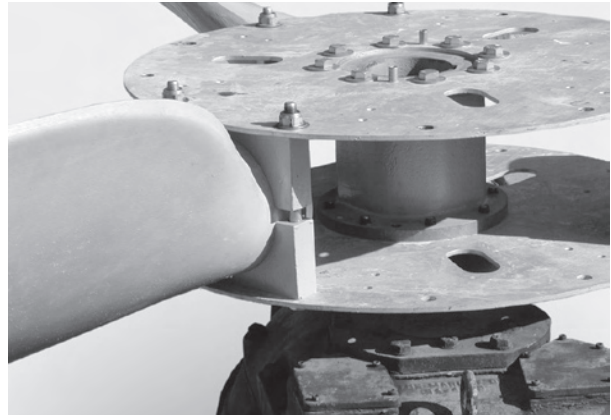

Figure 82 — Clamped-blade fan hub for large fans.

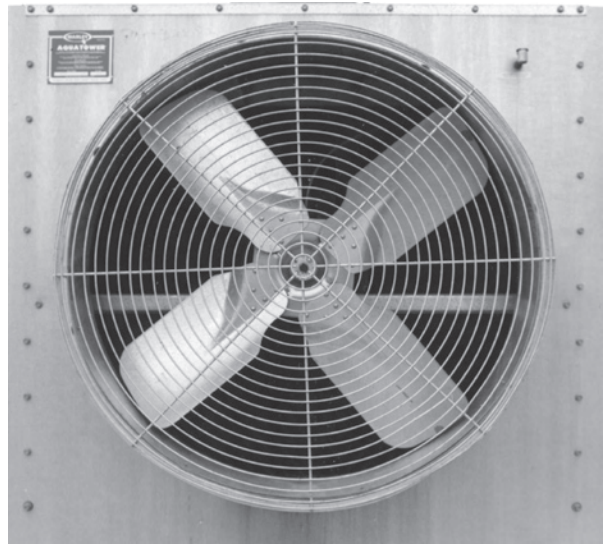

Figure 83 — Fixed-pitch, sheet metal fan used on smaller towers.

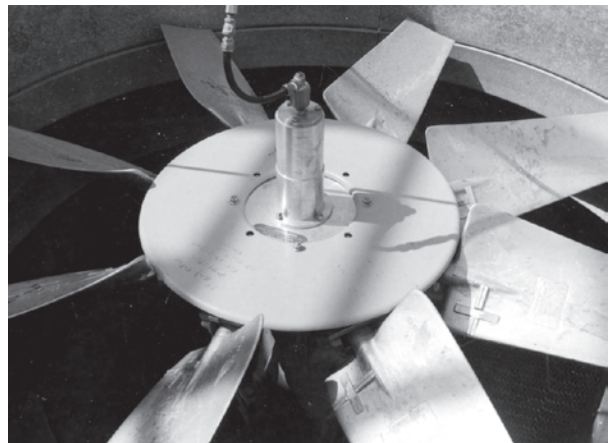

Figure 84 — Automatic variable-pitch fan used to manipulate air flow and fan horsepower.

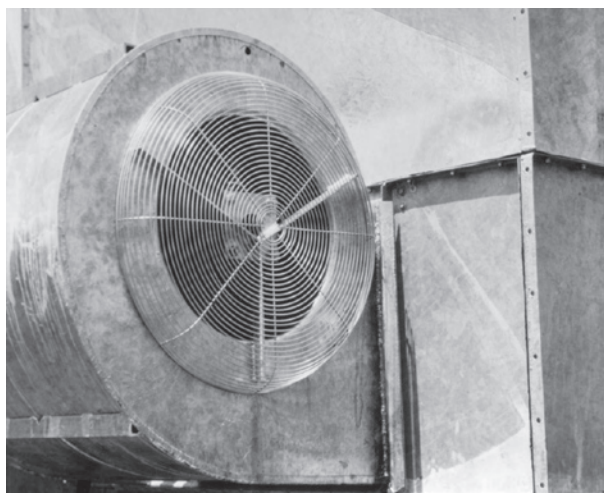

Figure 85 — Blower type fan.

iron castings, and wrought or cast aluminum are in general use as hub materials. Where hub and blades are of dissimilar metals, they must be insulated from each other to prevent electrolytic corrosion.

Smaller diameter fans are customarily of galvanized sheet metal construction with fixed-pitch, non-adjustable blades. These fans are matched to differing air flow requirements by changing the design speed.

2. **Automatic Variable-Pitch Fans:** These are propeller fans on which a pneumatically actuated hub controls the pitch of the blades in unison. (Fig. 84) Their ability to vary airflow through the tower in response to a changing load or ambient condition – coupled with the resultant energy savings, and ice control – make them an optional feature much in demand. (Sects. I-H-1 & V-F)
3. **Centrifugal Fans:** These are usually of the double inlet type, used predominantly on cooling towers designed for indoor installations. Their capability to operate against relatively high static pressures makes them particularly suitable for that type of application. However, their inability to handle large volumes of air, and their characteristically high input horsepower requirement (approximately twice that of a propeller fan) limits their use to relatively small applications.

Three types of centrifugal fans are available: 1) forward curve blade fans, 2) radial blade fans and 3) backward curve blade fans. The characteristics of the forward curve blade fan makes it the most appropriate type for cooling tower service. By virtue of the direction and velocity of the air leaving the fan wheel, the fan can be equipped with a comparatively small size housing, which is desirable from a structural standpoint. Also, because the required velocity is generated at a comparatively low speed, forward curve blade fans tend to operate quieter than other centrifugal types.

Centrifugal fans are usually of sheet metal construction, with the most popular protective coating being hot-dip galvanization. Damper mechanisms are also available to facilitate capacity control of the cooling tower.

4. **Fan Laws:** All propeller type fans operate in accordance with common laws. For a given fan and cooling tower system, the following is true:
  - a. The capacity (cfm) varies directly as the speed (rpm) ratio, and directly as the pitch angle of the blades relative to the plane of rotation.
  - b. The static pressure ( $h_s$ ) varies as the square of the capacity ratio.
  - c. The fan horsepower varies as the cube of the capacity ratio.
  - d. At constant cfm, the fan horsepower and static pressure vary directly with air density.

If, for example, the capacity (cfm) of a given fan were decreased by 50 percent (either by a reduction to half of design rpm, or by a reduction in blade pitch angle at constant speed), the capacity ratio would be 0.5. Concurrently, the static pressure would become 25 percent of before, and the fan horsepower would become 12.5 percent of before. These characteristics afford unique opportunities to combine cold water temperature control with significant energy savings, as described in Section V-F of this manual.

Selected formulas, derived from these basic laws, may be utilized to determine the efficacy of any particular fan application:

#### Symbols:

- $Q$  = Volume of air handled (cfm). Unit: cu ft per min.
- $A$  = Net flow area. Unit: sq ft.
- $V$  = Average air velocity at plane of measurement. Unit: ft per sec.
- $g$  = Acceleration due to gravity. Unit: 32.17 ft per sec per sec.
- $D$  = Density of water at gauge fluid temperature. Unit: lb per cu ft. (See Table 3).
- $d$  = Air density at point of flow. Unit: lb per cu ft. (See Table 4).
- $h_s$  = Static pressure drop through system. Unit: inches of water.
- $h_v$  = Velocity pressure at point of measurement. Unit: inches of water.
- $h_t$  = Total pressure differential (=  $h_s + h_v$ ). Unit: inches of water.
- $v_r$  = Fan cylinder velocity recovery capability. Unit: percent.

Thermal performance of a cooling tower depends upon a specific mass flow rate of air through the fill (pounds of dry air per minute), whereas the fan does its job purely in terms of volume (cubic feet per minute). Since the specific volume of air (cubic feet per pound) increases with temperature (See Fig. 18 & Table 4), it can be seen that a larger volume of air leaves the



tower than enters it. The actual cfm handled by the fan is the product of mass flow rate times the specific volume of dry air corresponding to the temperature at which the air leaves the tower. This volumetric flow rate is the "Q" used in the following formulas, and it must be sufficient to produce the correct mass flow rate or the tower will be short of thermal capacity.

Utilizing appropriate cross-sectional flow areas, velocity through the fan and fan cylinder can be calculated as follows:

$$V = \frac{Q}{A \times 60} \quad (9)$$

It must be understood that "A" will change with the plane at which velocity is being calculated. Downstream of the fan, "A" is the gross cross-sectional area of the fan cylinder. **At** the fan, "A" is the area of the fan **less** the area of the hub or hub cover.

Velocity pressure is calculated as follows:

$$h_v = \frac{V^2 \times 12 \times d}{2 \times g \times D} \quad (10)$$

If "V" in Formula (10) represents the velocity through the fan, then  $h_v$  represents the velocity pressure for the fan itself ( $h_{vf}$ ). Moreover, if the fan is operating within a non-flared-discharge fan cylinder, this effectively represents the total velocity pressure because of no recovery having taken place.

However, if the fan is operating within a flared, velocity-recovery type fan cylinder (Fig. 68),  $h_v$  must be recalculated for the fan cylinder exit ( $h_{ve}$ ), at the appropriate velocity, and applied in the following formula to determine total velocity pressure:

$$h_v = h_{vf} - [(h_{vf} - h_{ve}) \times v_r] \quad (11)$$

Although the value of  $v_r$  will vary with design expertise, and is empirically established, a value of 0.75 (75 percent recovery) is normally assigned for purposes of anticipating fan performance within a reasonably well-designed velocity-recovery cylinder.

The power output of a fan is expressed in terms of air horsepower (ahp) and represents work done by the fan:

$$aph = \frac{Q \times h_t \times D}{33,000 \times 12} \quad (12)$$

Static air horsepower is obtained by substituting static pressure ( $h_s$ ) for total pressure ( $h_t$ ) in Formula (12).

A great deal of research and development goes into the improvement of fan efficiencies, and those manufacturers that have taken a systems approach to this R&D effort have achieved results which, although incrementally small, are highly significant in the light of current energy costs. Static efficiencies and overall mechanical (total) efficiencies are considered in the selec-

tion of a particular fan in a specific situation, with the choice usually going to the fan which delivers the required volume of air at the least input horsepower:

$$\text{Static Efficiency} = \frac{\text{static ahp}}{\text{input hp}} \quad (13)$$

$$\text{Total Efficiency} = \frac{\text{ahp}}{\text{input hp}} \quad (13)$$

It must be understood that input hp is measured at the fan shaft and does not include the drive-train losses reflected in actual motor brake horsepower (bhp). Input hp will normally average approximately 95 percent of motor bhp on larger fan applications.

### C. SPEED REDUCERS

The optimum speed of a cooling tower fan seldom coincides with the most efficient speed of the driver (motor). This dictates that a speed reduction, power transmission unit of some sort be situated between the motor and the fan. In addition to reducing the speed of the motor to the proper fan speed (at the least possible loss of available power) the power transmission unit must also provide primary support for the fan, exhibit long term resistance to wear and corrosion, and contribute as little as possible to overall noise level.

Speed reduction in cooling towers is accomplished either by differential gears of positive engagement, or by differential pulleys (sheaves) connected through V-belts. Typically, gear reduction units are applied through a wide range of horsepower ratings, from the very large down to as little as 5 hp. V-belt drives, on the other hand, are usually applied at ratings of 50 hp or less.

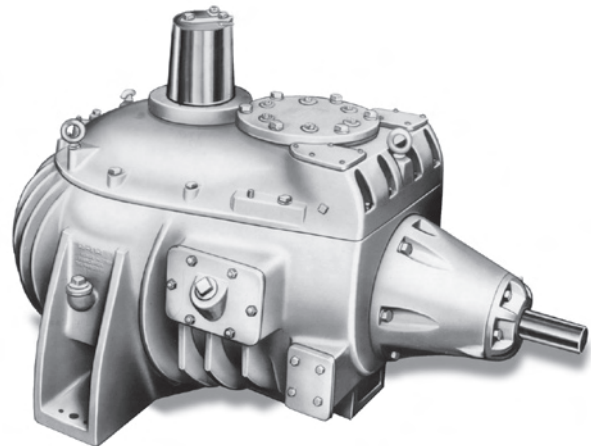

Figure 86 — Geareducer® type used for applied horsepowers above 75 hp.

1. **Gear Reduction Units:** Geareducers are available in a variety of designs and reduction ratios to accommodate the fan speeds and horsepowers encountered in cooling towers. (Fig. 86) Because of their ability to transmit power at minimal loss, spiral bevel and helical gear sets are most widely

utilized, although worm gears are also used in some designs. Depending upon the reduction ratio required, and the input hp, a Geareducer may use a single type gear, or a combination of types to achieve “staged” reduction. Generally, two-stage reduction units are utilized for the large, slower-turning fans requiring input horsepowers exceeding 75 bhp.

The service life of a Geareducer is directly related to the surface durability of the gears, as well as the type of service imposed (i.e. intermittent vs. continuous duty). The American Gear Manufacturers Association (AGMA) has established criteria for the rating of geared speed reducers, which are subscribed to by most reliable designers. AGMA Standard 420 defines these criteria and offers a list of suggested service factors. The Geareducer manufacturer will have established service factors for an array of ratios, horsepowers, and types of service, commensurate with good engineering practice. The Cooling Technology Institute (CTI) Standard 111 offers suggested service factors specifically for cooling tower applications.

Long, trouble-free life is also dependent upon the quality of bearings used. Bearings are normally selected for a calculated life compatible with the expected type of service. Bearings for industrial cooling tower Geareducers (considered as continuous duty) should be selected on the basis of a 100,000 hour  $L_{10}$  life.  $L_{10}$  life is defined as the life expectancy in hours during which 90 percent or more of a given group of bearings under a specific loading condition will still be in service. Intermittent duty applications provide satisfactory life with a lower  $L_{10}$  rating. An  $L_{10}$  life of 35,000 hours is satisfactory for an 8 to 10 hour per day application. It is equivalent, in terms of years of service, to a 100,000 hour  $L_{10}$  life for continuous duty.

Lubrication aspects of a Geareducer, of course, are as important to longevity and reliability as are the components that comprise the Geareducer. The lubrication system should be of a simple, non-complex design, capable of lubricating equally well in both forward and reverse operation. Remote oil level indicators (Fig. 87), and convenient location of fill and drain lines, simplify and encourage preventive maintenance. Lubricants and lubricating procedures recommended by the manufacturer should be adhered to closely.

2. **V-Belt Drives:** These are an accepted standard for the smaller factory-assembled cooling towers (Fig. 11), although most of the larger unitary towers (Fig. 12) are equipped with Geareducers. Correctly designed and installed, and well maintained, V-belt drives can provide very dependable service. The drive consists of the motor and fan sheaves, the bearing housing assembly supporting the fan, and the V-belts.

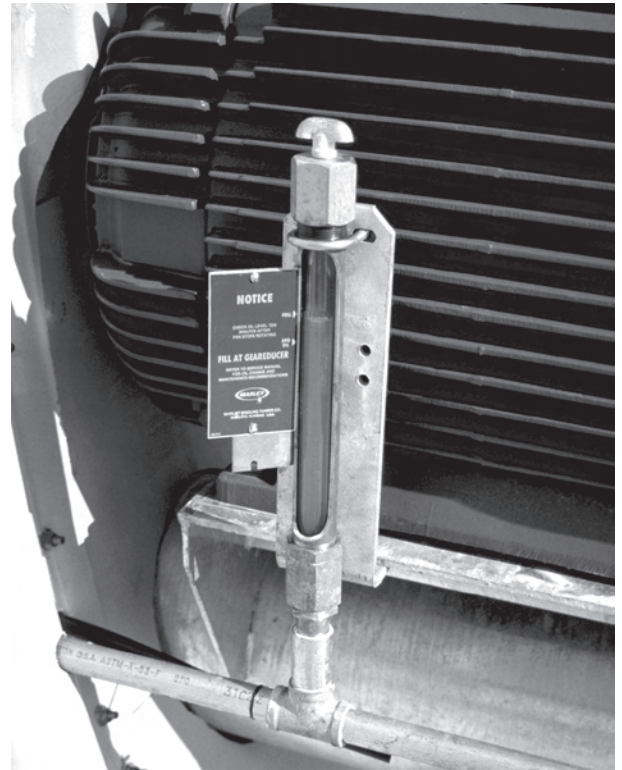

Figure 87 — Remote oil level indicator and drain connection.

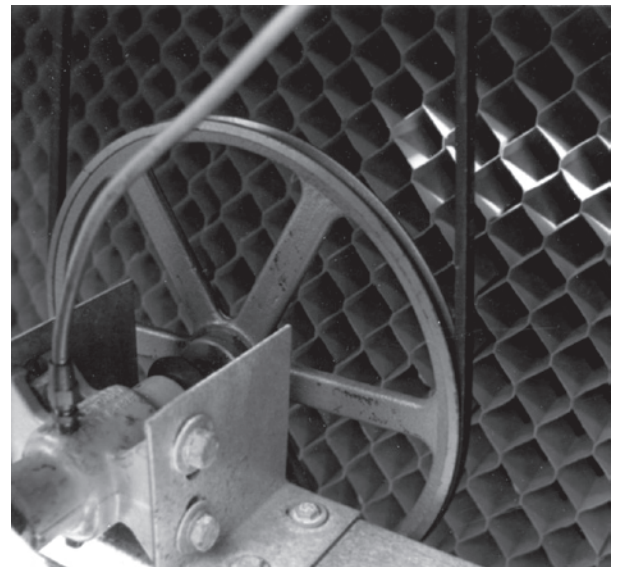

Figure 88 — Belt fan-drive system for smaller fans.

V-belts (as opposed to cog belts) are used most commonly for cooling tower service. A variety of V-belt designs is available, offering a wide assortment of features. Most of these designs are suitable for cooling tower use. In many cases, more than one belt is required to transmit

power from the motor to the fan. Multiple belts must be supplied either as matched sets, measured and packaged together at the factory, or as a banded belt having more than one V-section on a common backing.

Various types of bearings, and bearing housing assemblies, are utilized in conjunction with V-belt drives. Generally, sleeve bearings are used on smaller units and ball or roller bearings on the larger units, with oil being the most common lubricant. In all cases, water slinger seals are recommended to prevent moisture from entering the bearings.

Belts wear and stretch, and belt tension must be periodically adjusted. Means for such adjustment should be incorporated as part of the motor mount assembly. Stability and strength of the mounting assembly is of prime importance in order to maintain proper alignment between the driver and driven sheaves. (Fig. 89) Misalignment is one of the most common causes of excessive belt and sheave wear.

Manually adjustable pitch sheaves are occasionally provided to allow a change in fan speed. These are of advantage on indoor towers, where the ability to adjust fan speed can sometimes compensate for unforeseen static pressure.

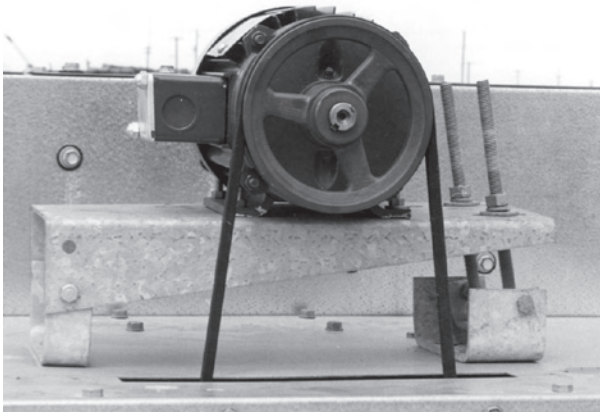

Figure 89 — Adjustable motor mount for V-belt driven fan (belt guard removed).

#### D. DRIVESHAFTS

The driveshaft transmits power from the output shaft of the motor to the input shaft of the Geareducer. Because the driveshaft operates within the tower, it must be highly corrosion resistant. Turning at full motor speed, it must be well balanced — and capable of being re-balanced. Transmitting full motor power over significant distances, it must accept tremendous torque without deformation. Subjected to long term cyclical operation, and occasional human error, it must be capable of accepting some degree of misalignment.

Driveshafts are described as “floating” shafts, equipped with flexible couplings at both ends. Where only normal corrosion is anticipated and

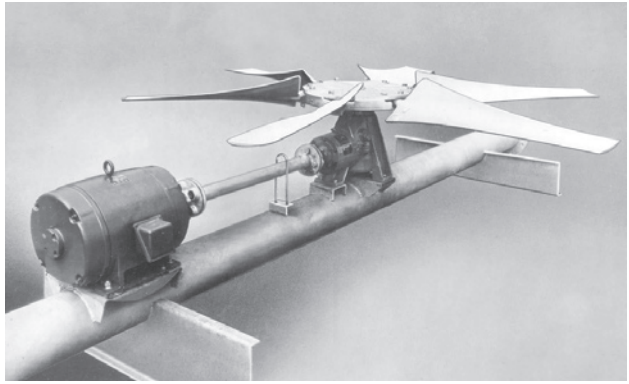

Figure 90 — Driveshaft in relatively small fan drive application.

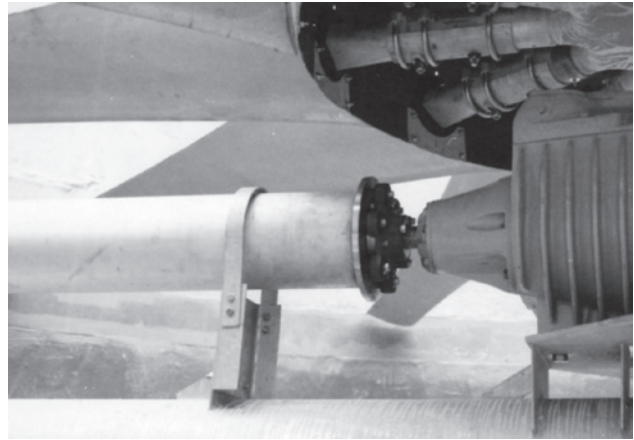

Figure 91 — Closeup of larger driveshaft showing guard.

cost is of primary consideration, shafts are fabricated of carbon steel, hot-dip galvanized after fabrication. (Fig. 90) Shafts for larger industrial towers, and those that will be operating in atmospheres more conducive to corrosion, are usually fabricated of tubular stainless steel. (Fig. 91) The yokes and flanges which connect to the motor and Geareducer shafts are of cast or welded construction, in a variety of materials compatible with that utilized for the shaft.

Flexible couplings transmit the load between the driveshaft and the motor or Geareducer, and compensate for minor misalignment. A suitable material for use in a cooling tower's saturated effluent air stream is neoprene, either in solid grommet form (Fig. 92), or as neoprene-impregnated fabric (Fig. 93), designed to require no lubrication and relatively little maintenance. Excellent service records have been established by the neoprene flexible couplings, both as bonded bushings and as impregnated fabric disc assemblies. These couplings are virtually impervious to corrosion, and provide excellent flexing characteristics.

It is very important that driveshafts be properly balanced. Imbalance not only causes tower vibration, but also induces higher loads and excessive wear on the mechanical equipment coupled to the shaft. Most cooling tower driveshafts operate at speeds approaching 1800 rpm. At these speeds, it is necessary that the shafts be dynamically balanced to reduce vibrational forces to a minimum.

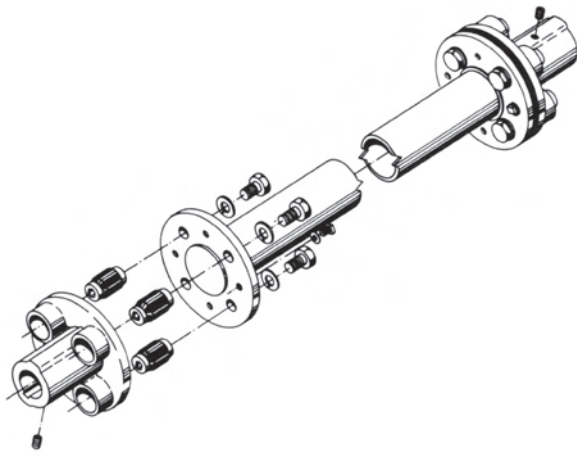

Figure 92 — Grommet type driveshaft coupling.

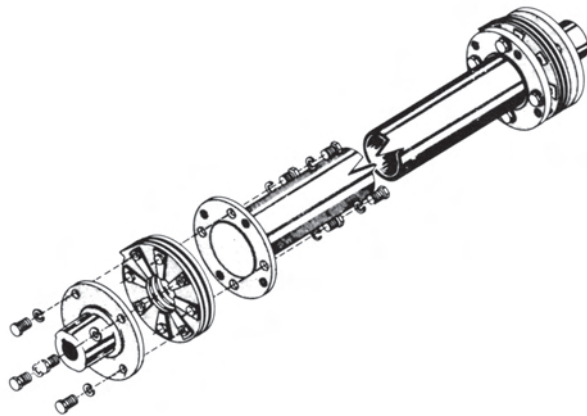

Figure 93 — Disc type driveshaft coupling.

## E. VALVES

Valves are used to control and regulate flow through the water lines serving the tower. Valves utilized for cooling tower application include stop valves, flow-control valves, and make-up regulator valves. The types of valves, quantity required, and complexity of design are dictated by the type and size of the tower, and the requirements of the user.

1. **Stop Valves:** These are usually of the gate or butterfly type. They are used on both counterflow and crossflow towers to regulate flow in multiple-riser towers, and to stop flow in a particular riser for cell maintenance. Because flow-control valves (see following) are customarily supplied with crossflow towers, stop valves are not normally considered mandatory in their case. As a rule, stop valves are located in a portion of site piping for which the user is responsible. In more complex concrete tower designs, stop valves may be incorporated into the internal distribution system and provided by the cooling tower manufacturer. In these cases, slide-gate type valves are used successfully when relatively low pressures are involved.

2. **Flow-Control Valves:** In the realm of cooling towers, these are considered to be valves that discharge to atmosphere. Essentially, they are end-of-line valves, as opposed to in-line valves. They are used in crossflow towers to equalize flow between distribution basins of a tower cell, as well as between cells of a multi-cell tower. (Figs. 61 & 94) Properly designed, they may be used to shut off flow to selected distribution basins, for interim cleaning and maintenance, while the remainder of the tower continues to operate.

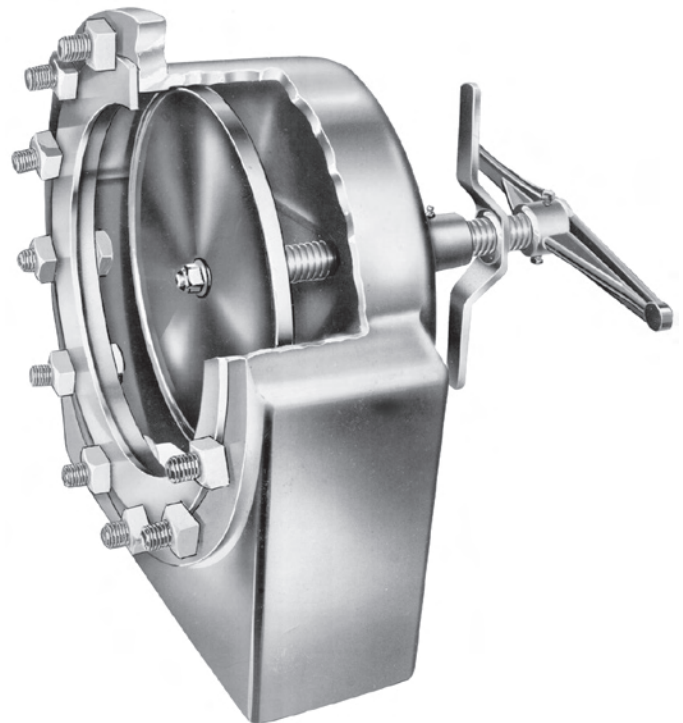
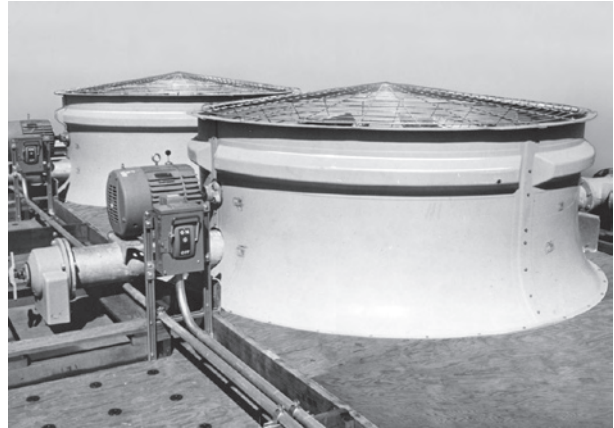

Figure 94 — Flow control valve.

3. **Make-Up Valves:** These are valves utilized to automatically replenish the normal water losses from the system. (Fig. 65) They are normally provided by the manufacturer where the cold water collection basin is part of his scope of work. Otherwise, they are left to the user's responsibility. Various means of make-up are described in Section II-D-4.

**F. SAFETY CONSIDERATIONS**

Fan cylinders less than 6 feet high must be equipped with suitable fan guards (Fig. 95) for the protection of operating personnel. Driveshafts must operate within retaining guards (Fig. 91) to prevent the driveshaft from encountering the fan if the coupling should fail. The motor shaft and outboard driveshaft coupling should either be within the confines of the fan cylinder, or enclosed within a suitable guard.



*Figure 95 — Low height fan cylinders require fan guards.*

## Electrical Components

### A. MOTORS

Electric motors are used almost exclusively to drive the fans on mechanical draft cooling towers, and they must be capable of reliable operation under extremely adverse conditions. The high humidity produced within the tower, plus the natural elements of rain, snow, fog, dust, and chemical fumes present in many areas combine to produce a severe operating environment.

1. **Motor Enclosures:** The two basic types of motor enclosures are **Open** and **Totally Enclosed**. The Open Motor circulates external air inside the enclosure for cooling, whereas a Totally Enclosed motor prevents outside air from entering the enclosure. Both types of motors are available in either fractional or integral horsepower.

Open motors are further classified as **Drip-proof**, **Splash-Proof**, **Guarded**, and **Weather Protected**, the distinction between them being the degree of protection provided against falling or air-borne water gaining access to live and rotating parts. Drip-proof motors, as defined by NEMA, are seldom used on cooling towers and never on outside installations. Drip-proof motors now marketed (sometimes called "protected") usually meet NEMA requirements for Weather Protected Type I enclosures, except they will not prevent the passage of a  $\frac{3}{4}$ " diameter rod. These enclosures are widely used on cooling towers where they can be installed outside the humid air stream. NEMA-defined Weather-Protected Type II enclosures require oversize housings for special air passages to remove air-borne particles. This type enclosure is not available in the motor sizes normally used on cooling towers.

Totally Enclosed motors used on cooling towers are classified as Non-ventilated (TENV), Fan-cooled (TEFC), Air-over (TEAO), and Explosion-Proof. Whether a motor is TENV or TEFC is dependent upon the need for an internally-mounted fan to keep the operating temperature of the motor within the rating of its insulation. Air-Over motors are TEFC motors without the fan, and must have an outside cooling source. Totally Enclosed motors are recommended and used for locations where fumes, dust, sand, snow, and high humidity conditions are prevalent, and they can provide a high quality installation either in or out of the air stream provided the typical problems of mounting, sealing and servicing are properly addressed. In all cases, Totally Enclosed motors should be equipped with drain holes, and Explosion-Proof motors should be equipped with an approved drain fitting.

Explosion-Proof motors are manufactured and sold for operation in hazardous atmospheres,

as defined by the National Electrical Code. The motor enclosure must withstand an explosion of the specified gas, vapor or dust within it, and prevent the internal explosion from igniting any gas, vapor or dust surrounding it. The motors are U.L. approved, and marked to show the Class, Group, and operating temperature (based on 40°C ambient) for which they are approved. In applying these motors, no external surface of the operating motor can have a temperature greater than 80 percent of the ignition temperature of the gas, vapor or dust involved.

The National Electrical Code defines hazardous locations by Class, Group and Division. Class I locations contain flammable gases or vapors; Class II locations contain combustible dust; and Class III locations contain ignitable fibers or flyings. "Group" defines the specific gas, vapor, dust, fiber or flying. "Division" defines whether the explosive atmosphere exists continuously (Division 1), or only in case of an accident (Division 2).

Motors for Division 1 applications must be Explosion-Proof. Standard Open or Totally Enclosed motors that do not have brushes, switching mechanisms, or other arc-producing devices, can be used in Class I, Division 2 applications. In some cases, they can also be used in Class II, Division 2 and Class III, Division 2 applications.

2. **Motor Design:** Three phase squirrel cage induction motors have become the standard on water cooling towers. They do not have the switches, brushes or capacitors of other designs and, therefore, require somewhat less maintenance. Where three phase power is not available, single phase capacitor-start motors may be used, usually not exceeding 7.5 horsepower. *Concerned cooling tower manufacturers will supply motors that are a few steps beyond "off-the-shelf" quality.* These motors are usually purchased from specifications developed after comprehensive, rigorous testing under simulated operating conditions.
3. **Two-Speed Motors:** Two-speed motors for fan drive are of a variable torque design, in which the torque varies directly with the speed, with 1800/900 rpm being the most common speeds. Single-winding design motors enjoy greatest utilization, since they are smaller in size and less expensive than those of a two-winding design.

Every cooling tower installation deserves definite consideration of the use of two-speed motors. Whether operated seasonally or year-round, there will be periods when a reduced load and/or a reduced ambient will permit satisfactory cold water temperatures with the fans

operating at half-speed. The benefits accrued from this mode of operation (Sects. I-H, III-B & V-F) will usually offset the additional cost of two-speed motors in a relatively short time.

Additionally, since nighttime operation is normally accompanied by a reduced ambient, some operators utilize two-speed motors to preclude a potential noise complaint. (See Sect. V-G)

4. **High-Efficiency Motors:** Several motor manufacturers provide high-efficiency designs that are suitable for use on cooling towers. These motors are in the same frame sizes as standard motors, but utilize more efficient materials. While the efficiency will vary with the manufacturer and the size of the motor, the efficiency will always be higher than that manufacturer's standard motor. Naturally, there is a price premium for high-efficiency motors, which must be evaluated against their potential for energy savings.

5. **Motor Insulation:** One of the most important factors contributing to long service life in an electric motor is the quality of the insulation. It must withstand thermal aging, contaminated air, moisture, fumes, expansion and contraction stresses, mechanical vibration and shock, as well as electrical stress.

Insulation is categorized by classes, which establish the limit for the maximum operating temperature of the motor. Classes A, B, F & H are used in the U.S.A., with Class A carrying the lowest temperature rating and Class H the highest. Standard integral horsepower motors have Class B insulation, and are designed for a maximum altitude of 3300 feet and a maximum ambient temperature of 40°C. Class F insulation is used for higher altitudes, as well as higher ambients, and is gaining increased use as a means of improving the service factor of a motor of given frame size.

6. **Motor Service Factor:** The service factor (s.f.) of a motor is an indication of its maximum allowable continuous power output as compared to its nameplate rating. A 1.0 service factor motor should not be operated beyond its rated horsepower at design ambient conditions, whereas a 1.15 service factor motor will accept a load 15 percent in excess of its nameplate rating. Usually, motor manufacturers will apply the same electrical design to both motors, but will use Class B insulation on 1.0 service factor motors and Class F insulation on 1.15 service factor motors. Class B insulation is rated at a total temperature of 130°C and Class F is rated at 155°C.

More importantly, a 1.15 service factor motor operates at a temperature from 15°C to 25°C lower (compared to the temperature rating of its insulation) than does a 1.0 service factor motor operating at the same load. This, of course, results in longer insulation life and, therefore, longer service life for the motor. For this reason, responsible cooling tower manufacturers will recommend the use of 1.15 service factor mo-

tors for fan loads at or near nominal horsepower ratings.

Since increased air density increases fan load (See Sect. III-B), an added attraction for using 1.15 service factor motors is that there is less chance of properly sized overloads tripping out during periods of reduced heat load and low ambient temperatures.

7. **Motor Heaters:** Although the insulation utilized in cooling tower motors is considered to be non-hygroscopic, it does slowly absorb water and, to the degree that it does, its insulation value is reduced. Also, condensed moisture on insulation surfaces can result in current leakage between pin holes in the insulation varnish. Because of this, it is advisable to keep the inside of the motor dry.

This can be done by keeping the temperature inside the motor 5°C to 10°C higher than the temperature outside the motor. Motors in continuous service will be heated by the losses in the motor, but idle motors require the addition of heat to maintain this desired temperature difference.

One recommended method of adding heat is by the use of electric space heaters, sized and installed by the motor manufacturer. Another method is single phase heating, which is simply the application of reduced voltage (approximately 5 to 7.5 percent of normal) to two leads of the motor winding. Both of these methods require controls to energize the heating system when the motor is idle. If low voltage dynamic braking (Sect. VI-F) is used to prevent an inoperative motor from rotating, it will add sufficient heat to the motor windings to prevent condensation.

8. **Motor Torques:** High starting torque motors are neither required nor recommended for cooling tower fan drives. Normal torque motors perform satisfactorily for both propeller and centrifugal fans, and cause far less stress on the driven components. Normal torque motors should be specified for single-speed applications, and variable torque in the case of two-speed.

There are five points along a motor speed-torque curve that are important to the operation of a cooling tower fan drive; 1) locked-rotor torque, 2) pull-up torque (minimum torque during acceleration), 3) breakdown torque (maximum torque during acceleration), 4) full load torque, and 5) maximum plugging torque (torque applied in reversing an operating motor). Compared to full load torque, the average percentage values of the other torques are: locked-rotor torque = 200%; pull-up torque = 100%; breakdown torque = 300%; and plugging torque = 250%.

## B. MOTOR CONTROLS

Control devices and wiring, the responsibility for which usually falls to the purchaser, can also be subjected to demanding service situations. Controls serve to start and stop the fan motor and to

protect it from overload or power supply failure, thereby helping assure continuous reliable cooling tower operation. They are not routinely supplied as a part of the cooling tower contract but, because of their importance to the system, the need for adequate consideration in the selection and wiring of these components cannot be overstressed.

The various protective devices, controls, and enclosures required by most Electrical Codes are described in the following paragraphs. ***In all cases, motors and control boxes must be grounded.***

1. ***Fusible Safety Switch or Circuit Breaker:*** This device provides the means to disconnect the controller and motor from the power circuit. It also serves to protect the motor-branch-circuit conductors, the motor control apparatus, and the motors against overcurrent due to short circuits or grounds. It must open all ungrounded conductors and be visible (not more than 50 feet distant) from the controller, or be designed to lock in the open position. The design must indicate whether the switch is open or closed, and there must be one fuse or circuit breaker in each ungrounded conductor. A disconnect switch must be horsepower rated, or must carry 115 percent of full load current and be capable of interrupting stalled-rotor current. A circuit breaker must also carry 115 percent of full load current and be capable of interrupting stalled rotor current.
2. ***Non-Fused Disconnect Switch:*** This switch is required at the cooling tower only if the fusible safety switch or circuit breaker either cannot be locked in the open position, or cannot be located in sight of the motor.
3. ***Manual and Magnetic Starters:*** These controls start and stop the motor. They also protect the motor, motor control apparatus, and the branch-circuit conductors against excessive heating caused by low or unbalanced voltage, overload, stalled rotor, and too frequent cycling. Starter requirements are determined by the basic horsepower and voltage of the motor. Overloads in a starter are sized to trip at not more than 125 percent of full load current for motors having a 1.15 or higher service factor, or 115 percent of full load current in the case of 1.0 service factor motors. Single phase starters must have an overload in one ungrounded line. A three phase starter must have overloads in all lines. If a magnetic controller is used, it may be actuated by temperature devices sensing the water temperature leaving the cold water basin of the cooling tower.
4. ***Control Enclosures:*** The National Electrical Manufacturers Association (NEMA) has established standard types of enclosures for control equipment. The types most commonly used in conjunction with cooling towers are as follows:
  - a. ***NEMA Type 1 – General Purpose:*** Intended primarily to prevent accidental contact with control apparatus. It is suitable for general purpose applications indoors, under normal

atmospheric conditions. Although it serves as a protection against dust, it is not dust-proof.

- b. ***NEMA Type 3 – Dusttight, Raintight, and Sleet-Resistant:*** Intended for outdoor use, and for protection against wind-blown dust and water. This sheet metal enclosure is usually adequate for use outdoors on a cooling tower. It has a watertight conduit entrance, mounting means external to the box, and provision for locking. Although it is sleet-resistant, it is not sleet-proof.
- c. ***NEMA Type 3R:*** This is similar to Type 3, except it also meets UL requirements for being rainproof. When properly installed, rain cannot enter at a level higher than the lowest live part.
- d. ***NEMA Type 4 – Watertight and Dusttight:*** Enclosure is designed to exclude water. It must pass a hose test for water, and a 24 hour salt spray test for corrosion. This enclosure may be used outdoors on a cooling tower. It is usually a gasketed enclosure of cast iron or stainless steel.
- e. ***NEMA Type 4X:*** Similar to Type 4, except it must pass a 200 hour salt spray test for corrosion. It is usually a gasketed enclosure of fiber reinforced polyester.
- f. ***NEMA Type 6 – Submersible, Watertight, Dusttight and Sleet-Resistant:*** Intended for use where occasional submersion may be encountered. Must protect equipment against a static head of water of 6 feet for 30 minutes.
- g. ***NEMA Type 12 – Dusttight and Driptight:*** Enclosure intended for indoor use. It provides protection against fibers, flyings, lint, dust, dirt, and light splashing.
- h. ***NEMA Type 7 – Hazardous Locations – Class I Air-Break:*** This enclosure is intended for use indoors in locations defined by the National Electrical Code for Class I, Division 1, Groups A, B, C or D hazardous locations.
- i. ***NEMA Type 9 – Hazardous locations – Class II Air-Break:*** Intended for use indoors in areas defined as Class II, Division 1, Groups E, F or G hazardous locations.

### C. WIRING SYSTEM DESIGN

The design of the wiring system for the fans, pumps, and controls is the responsibility of the Owner's engineer. Although the average installation presents no particular problem, there are some which require special consideration if satisfactory operation is to result. Conductors to motors must be sized both air 125 percent of the motor full load current, and for voltage drop. If the voltage drop is excessive at full load, the resultant increased current can cause overload protection to trip. (Although motors should be operated at nameplate voltage, they **can** be operated at plus or minus 10 percent of nameplate voltage.)



In a normal system with standard components, even the larger cooling tower fans will attain operating speed in less than 15 seconds. During this starting cycle, although the motor current is approximately 600 percent of full load current, the time delays in the overload protective devices prevent them from breaking the circuit.

Because of the high starting current, the voltage at the motor terminals is reduced by line losses. Within certain limits, the output torque of a motor varies as the square of the voltage. Thus, under starting conditions, the current increases, the voltage decreases, and the torque decreases, with the result that the starting time is increased. Long conductors which increase voltage drop, low initial voltage, and high inertia fans can all contribute to increased starting time, which may cause the protective devices to actuate. In extreme cases, the starting voltage may be insufficient to allow acceleration of the fan to full speed regardless of time.

The wiring system design must consider pertinent data on the available voltage (its actual value, as well as its stability), length of lines from the power supply to the motor, and the motor horsepower requirements. If this study indicates any question as to the startup time of the motor, the inertia of the load as well as that of the motor should be determined. This is the commonly known "flywheel" effect ( $WK^2$  factor). Once the  $WK^2$  of the load (referred to the

motor shaft) is obtained, the acceleration time can be determined using the motor speed-torque and speed-current curves, compared to speed-torque curves for the fan. If the calculated time and current is greater than allowed by the standard overload protection of the motor, the condition may be corrected by increasing voltage, increasing conductor size, or by providing special overload relays. Given no solution to the base problem, special motors or low inertia fans may be necessary.

#### **D. CYCLING OF MOTORS**

The high inrush current that occurs at motor startup causes heat to build up in the windings and insulation. For this reason, the number of start-stop or speed-change cycles should be limited in order to allow time for excessive heat to be dissipated. As a general rule, 30 seconds of acceleration time per hour should not be exceeded. A fan-motor system which requires 15 seconds to achieve full speed, therefore, would be limited to two full starts per hour. Smaller or lighter fans, of lesser inertia, permit greater frequency of cycling. The use of two speed motors adds control flexibility for systems with multiple fan cells. Variable frequency drives may be desirable, particularly with systems having a small number of fan cells.

Additional items of electrical equipment, of a more auxiliary nature, are discussed in Section VI.

## Specialized Tower Usage and Modifications

### A. GENERAL

Because of the vast number of cooling towers presently in operation on various buildings, and at a multitude of industrial sites, many people have come to recognize the classic shape of a cooling tower and are aware of its basic function. Hopefully, readers of this manual to this point will have fortified their recognition of the “standard” cooling tower and, perhaps, may have increased their understanding of how it accomplishes its task.

From time to time, concerns arise of an operational, economic, or environmental nature which are solved by thoughtful modifications to either the cooling tower’s normal operational mode, or to its basic design concept. Since operational concerns tend to be related to a specific site or locality, their solutions usually result in rather minor modifications which may not be apparent to the naked eye. However, economic and environmental concerns are much more broad in their impact, resulting in cooling tower evolutions which, although currently unique, give promise of extensive future utilization.

This Section describes various concerns and situations, along with the solutions which represent best current technology.

### B. WATER CONSERVATION

The evaporative cooling tower was originally conceived as a water conservation device, and it continues to perform that function with an ever-increasing efficiency, sacrificing only from 3% to 5% of the circulating water to evaporation, drift and blowdown. This conservation rate in excess of 95% is a boon to industrial areas which are confronted with a limited or costly water supply.

In certain regions, however, the scarcity of water is such that even the small normal losses are more than can reasonably be accepted., These situations have given rise to *Water Conservation* cooling towers of the type shown in Figure 96, in operation on a large southwestern electric generating plant. The installation pictured consists of two towers of five “cells” each, with each cell served by an array of five fans.

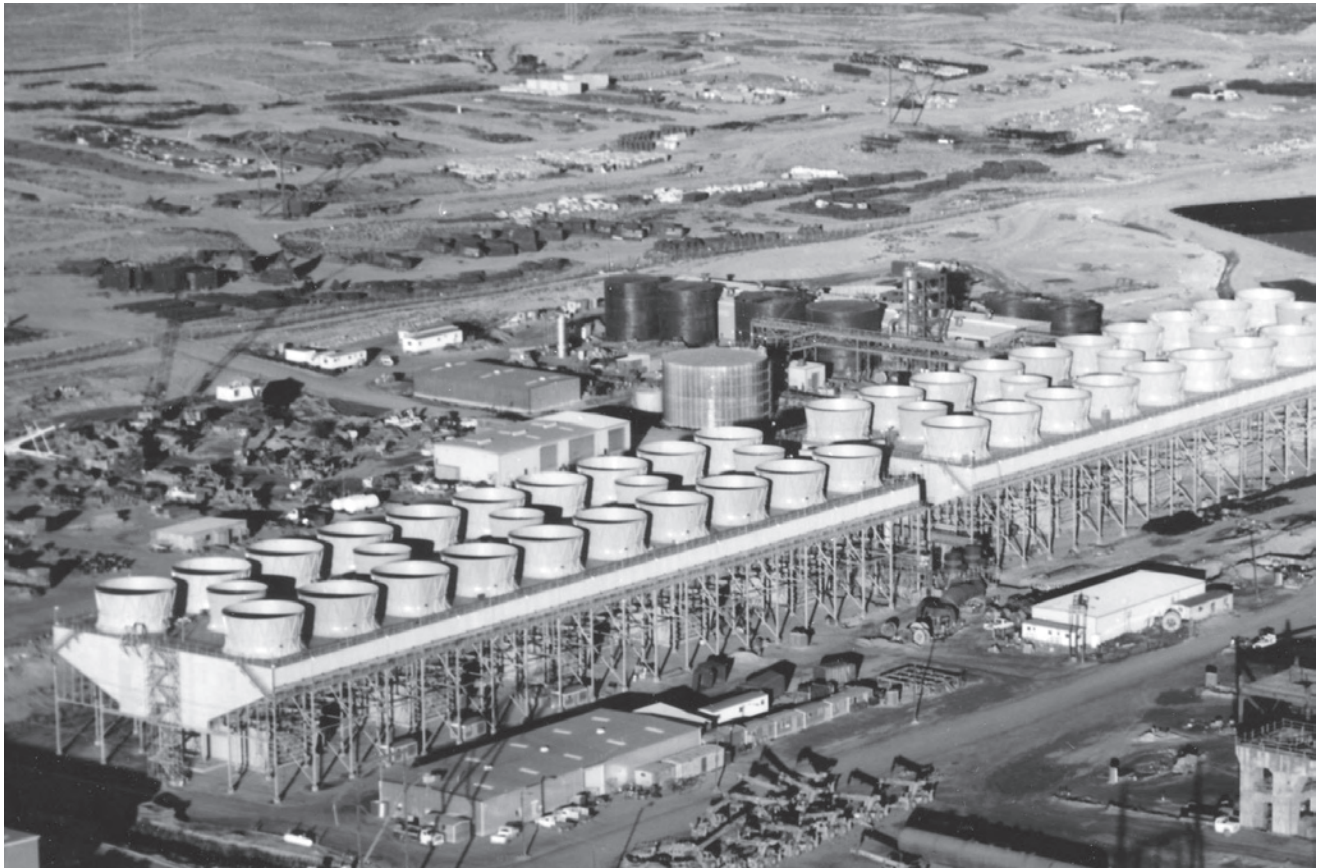

Figure 96 — Water conservation type cooling tower.

Figure 97 indicates the basic arrangement of one such "cell" in end and side elevations. As can be seen in the end elevation, water entering the cell flows first through dry-surface, finned-tube heat exchanger sections, where its temperature is sensibly reduced (without evaporation) to the minimum level permitted by the dry-bulb temperature of the air traversing the coils.

Upon exiting the coils, the path taken by the water is usually dictated by the need for further temperature reduction. If additional cooling is necessary, flow is directed to the "wet" section of the unit, where evaporative cooling is utilized to remove the remaining portion of the heat load. Conversely, if the temperature of the water leaving the dry section is adequate, the water is by-passed directly to the

cold water basin, avoiding the evaporative section altogether. In this case, the opportunity for water loss is limited to the relatively negligible amount of surface evaporation which may take place in the cold water basin.

At most, the evaporative section of a water conservation cooling tower will see but a fraction of the total annual heat load, with the magnitude of that fraction being related to the daily and seasonal temperature variations of the ambient air at site. Furthermore, since this reduced opportunity for evaporation results in proportionate reductions in drift and blowdown, total water consumption becomes an amount acceptable in all but the most arid regions.

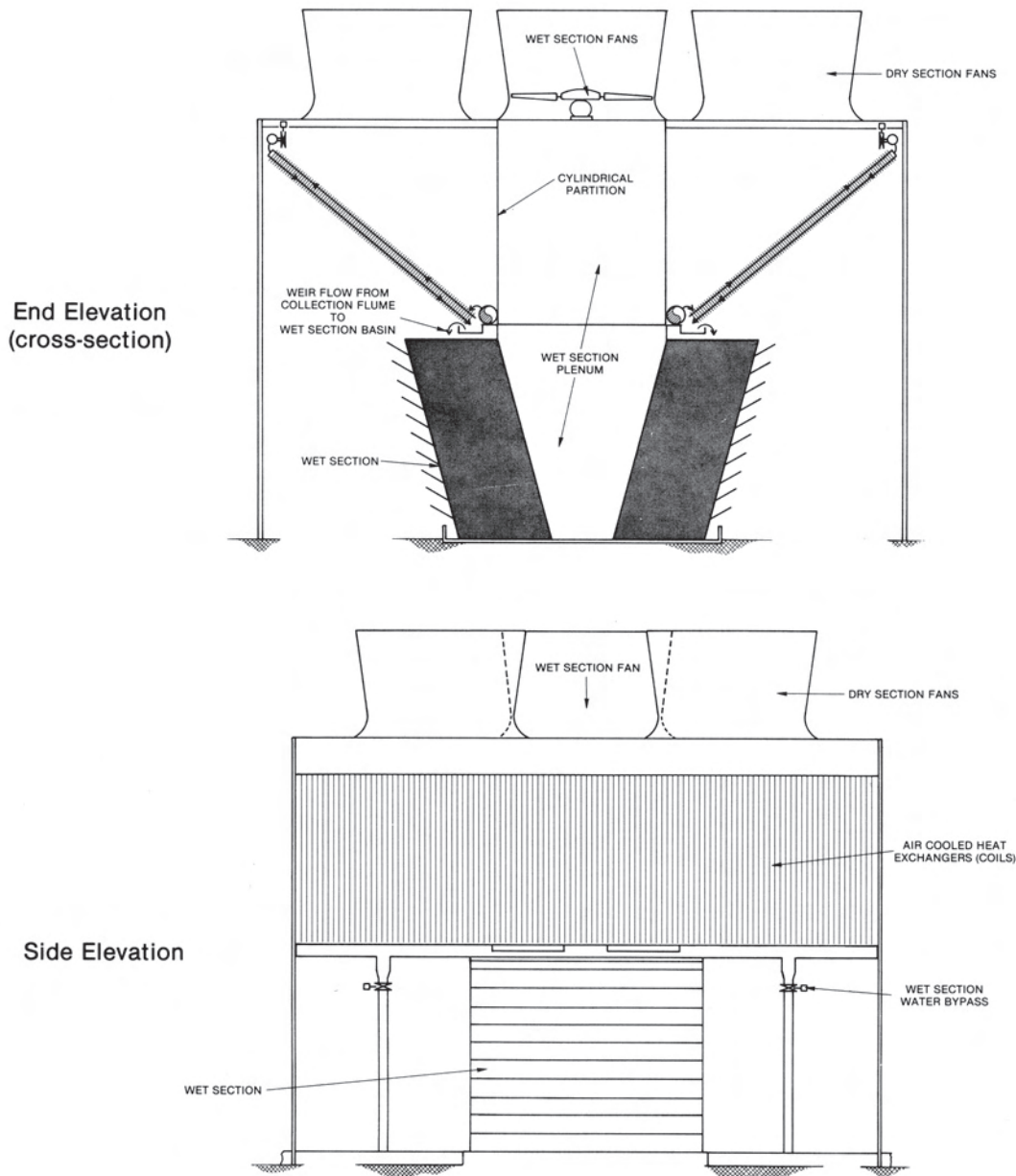

Figure 97 — Elevation of one "cell" of a Water Conservation tower.

Locations in which water is in critically short supply may require the use of a *dry tower*, utilizing only dry-surface, finned-tube heat exchanger sections for the sensible (non-evaporative) transfer of heat to the atmosphere. This type of cooling tower is conceptualized at an electric generating station in Figure 98, and shown in simplified cross section in Figure 99.

The use of air cooled condensers has become more common in recent years, and also parallel condensing systems with both a surface condenser/cooling tower and an air cooled condenser to enable lower back-pressures when some water is

available. With the development of steam turbines which will operate efficiently at back-pressures in the region of 8 to 12 inches (Hg), siting of power plants at highly desirable mine mouth locations with limited or no water available has become possible.

Since the thermal performance of such towers is influenced only by the dry-bulb temperature of the entering air, potential users must understand that the cold water temperature attainable may be some 20°F to 30°F higher than what would be expected from a normal evaporative type cooling tower. Nevertheless, their existence makes possible the utilization of sites not otherwise feasible.

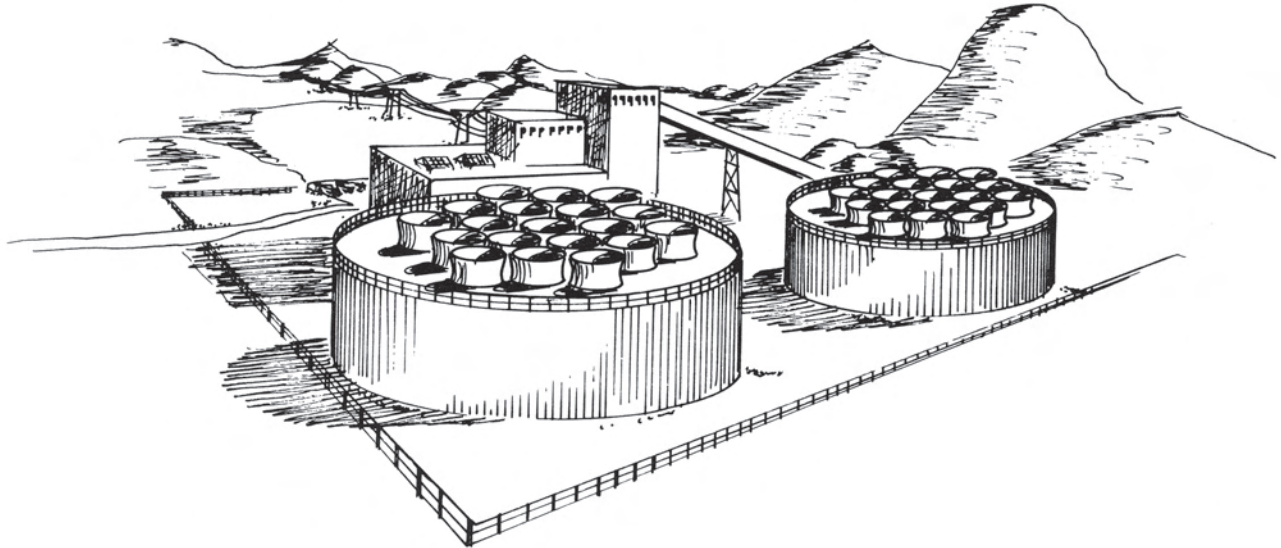

Figure 98 — Conceptual dry tower layout at an electric generating plant.

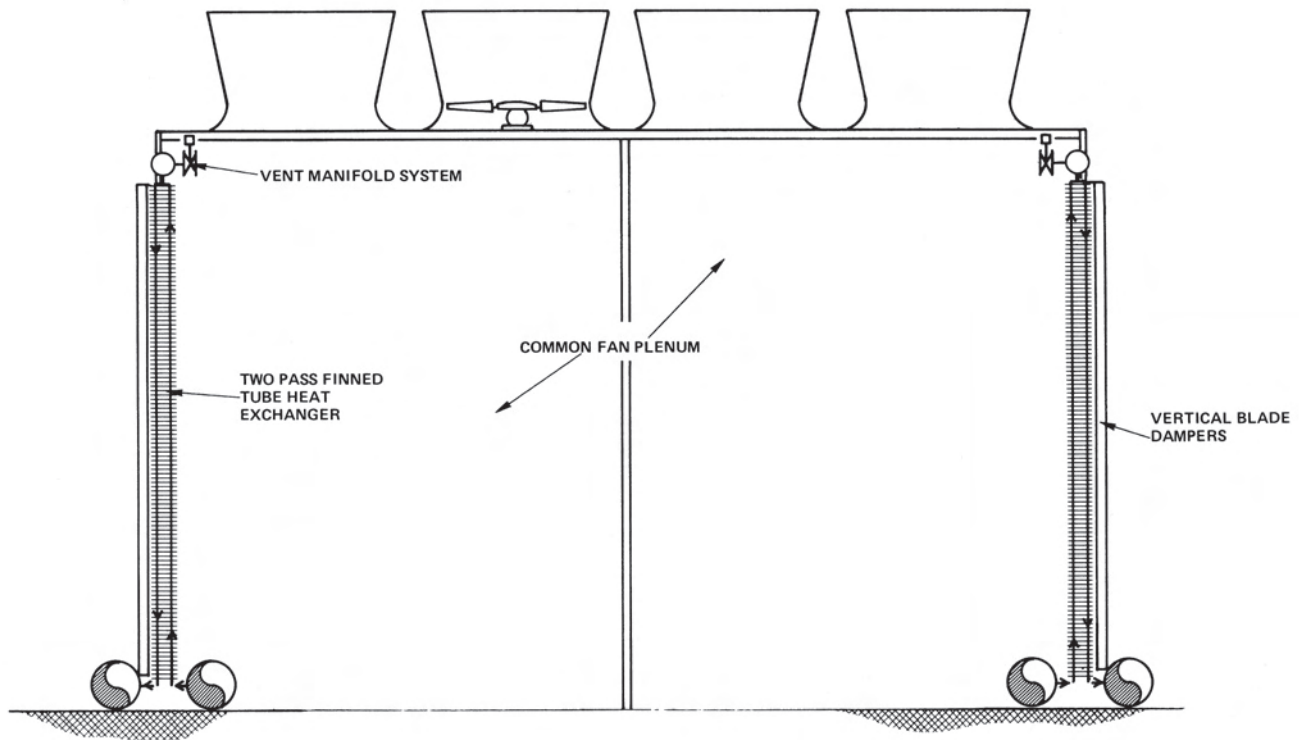

Figure 99 — Cross-section elevation of Dry tower.

### C. VISUAL IMPACT AND PLUME CONTROL

Industrial cooling towers can be large, imposing structures which sometimes tend to dominate a local scene. This is particularly true of hyperbolic natural draft towers. In most cases, local objections to the anticipated appearance of a cooling tower are overcome, or mollified, by good public relations on the part of the Owner. Other, more difficult cases may necessitate changing to a different type, shape, or size of cooling tower. Within the various types indicated in Section I of this manual are myriad models, permitting a wide choice of appearances. For a given heat load of any appreciable size, the tower shape may range from tall and relatively narrow, to long and low. It may also be split up into smaller, scattered towers, or built in round configuration to present a uniform appearance from all directions.

Physical appearance problems tend to be unique to specific locations and, invariably, are best solved by direct contact with a full-scope cooling tower manufacturer on an individual basis.

Cooling towers also produce a highly visible plume (Fig. 33), the density and persistency of which depends upon the heat load and atmospheric conditions. It is visible because of its elevated temperature and moisture content relative to the surrounding ambient air. The visible aspect of the plume can sometimes cause an unwarranted psychological reaction in that the layman observer

occasionally tends to equate it with smokestack emissions. In a more real sense, visible plumes which are capable of returning to grade level may produce a localized fog-like condition downwind of the tower. In freezing weather, the plume's moisture content can also cause frost or ice crystals to form on downwind structures.

Towers with elevated discharges inhibit a plume's ability to return to grade level. Two such towers are pictured in Figure 100. On the right-hand tower, the fan cylinders were extended well beyond their normal heights, such that the plume leaves the tower at an elevation approximately 100' above grade. The newer, left-hand tower has an extended structure and fan plenum to achieve the same discharge elevation, without the necessity of specialized support for tall stacks. In both cases, the possibility of plume-related ground fog or icing has been minimized.

Hyperbolic towers (Fig. 3), of course, accomplish this same effect, as do the fan-assisted natural draft towers. (Fig. 6)

Although tall stacks minimize the ground-effects of a plume, they can do nothing about its degree of saturation with water vapor and, therefore, can reduce neither its density nor its duration. The plume will remain visible for as long as it takes this saturated air stream to become sub-saturated by mixing with ambient air, with the density and persistency of the plume typically being much greater in winter-time than in summertime.

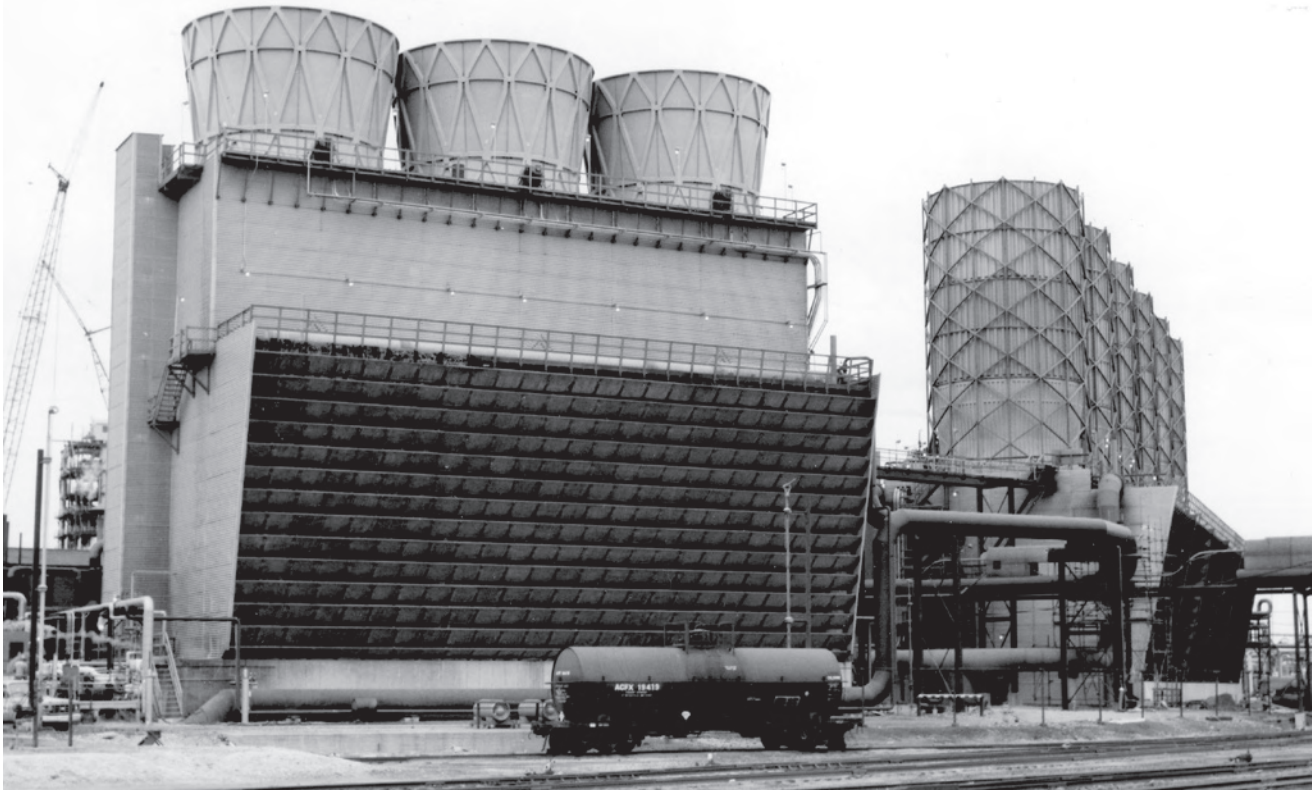

Figure 100 — Extended plenum and extended stack towers to reduce ground fogging.

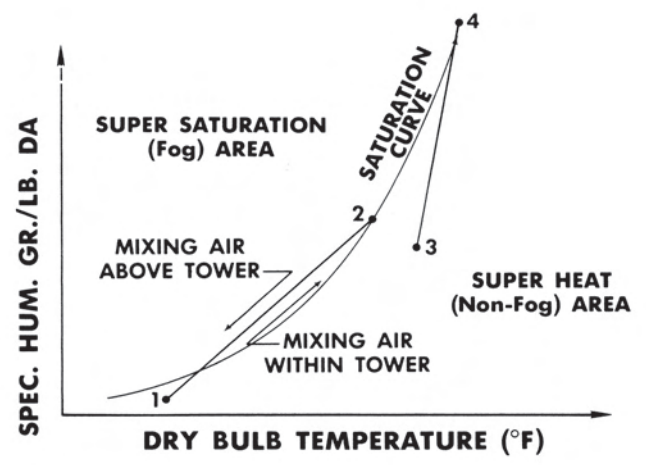
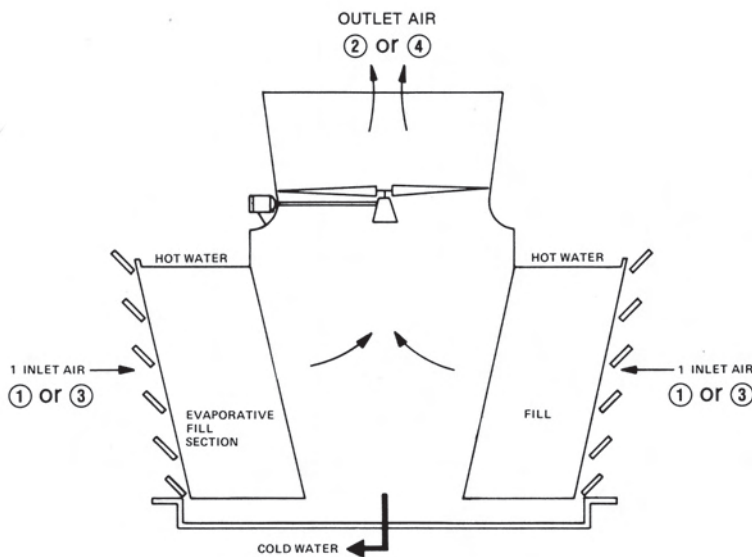

Figure 101 — Saturation of air in a normal evaporative cooling tower.

The reason for this can be seen in the air flow diagram and simplified psychrometric chart presented in Figure 101. During summertime, ambient air enters the tower at condition 3 and exits saturated at condition 4. After leaving the tower, this saturated air mixes with the ambient air along line 4-3, most of which mixing occurs in the invisible region below the saturation curve of the psychrometric chart. Primarily, the only reason why summertime plumes are visible at all is because of the time necessary for the inner core of the plume diameter to become affected by the ambient air. On the other hand, winter ambient air enters the tower at condition 1, exiting saturated at condition 2 and returning to ambient conditions along line 2-1. As can be seen, most of this mixing occurs in the region of super-saturation, which causes the visible plume to be very dense

and very persistent.

Figure 102 indicates the arrangement and function of a **Plume Abatement** cooling tower, designed to drastically reduce both the density and persistency of the plume. Incoming hot water flows first through the dry (finned-tube coil) sections, then through the wet (evaporative) fill section. Parallel streams of air flow across the coil sections and through the fill sections, leaving the coil sections at dry condition 3, and leaving the fill sections at saturated condition 2. These two separate streams of air then mix together going through the fan, along the lines 3-4 and 2-4 respectively, exiting the fan cylinder at sub-saturated condition 4. This exit air then returns to ambient conditions along line 4-1, avoiding the region of super-saturation (and visibility) altogether in most cases.

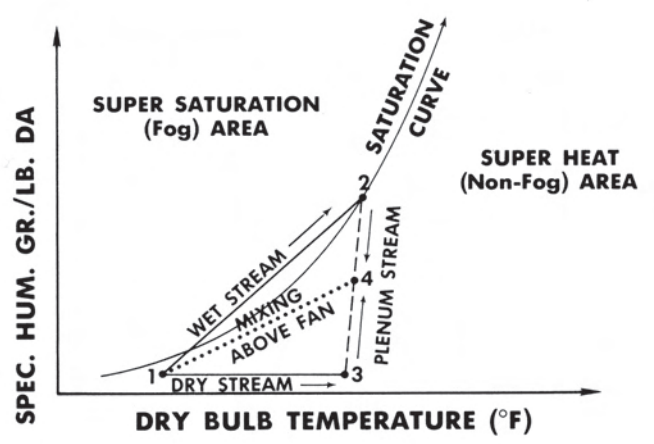
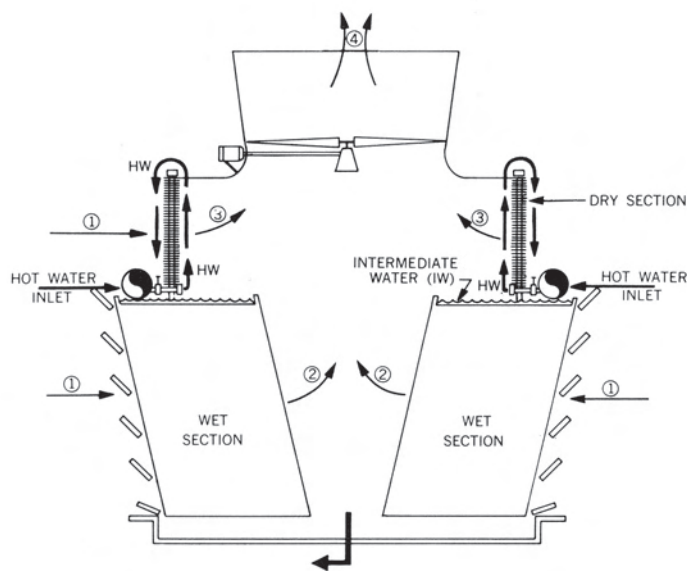

Figure 102 — Partial desaturation of air in a Parallel Path Plume Abatement cooling tower.

Obviously, the degree of plume abatement will depend upon the ambient air characteristics that establish condition 1, and upon the ratio of coil sections to wet fill sections which establishes condition 4. Increasing the proportion of dry sections causes condition 4 to move toward condition 3, decreasing the angle formed by condition line 4-1 and improv-

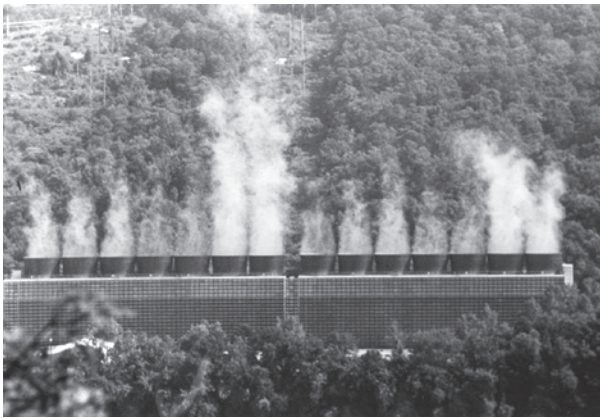

Figure 103 — Crossflow tower with partial plume abatement.

ing the plume abatement capability of the tower. Such an increase in coil proportion, however, also increases the cost of the tower.

Figure 103 shows two towers of seven fan-cells each, currently in operation at a power plant. Five of the fan-cells on each seven-cell tower are equipped with coil sections for plume abatement, and it is self-evident as to which cells are plume abated and which are not. Had this photograph been taken in the wintertime, the difference would have been considerably more dramatic. The reason why there is a small visible plume from the abated cells is because the wet and dry air masses tend to follow flow paths through the fan, so that the combined flow exits the fan cylinder in streamlines. However, as evidenced by Figure 103, the interspersion of very dry air promotes rapid desaturation.

Although desaturation of the leaving air stream can be accomplished with a number of configurations, the parallel-path air flow arrangement depicted in Figure 102 is best for long term thermal performance reliability. Figures 104 & 105 show series-path arrangements wherein the warm water coils serve to desaturate the air stream either before or after it traverses the evaporative fill section. However, coils arranged in close proximity to the fill are subjected to raw water impingement, which can result in scaling and restricted air flow.

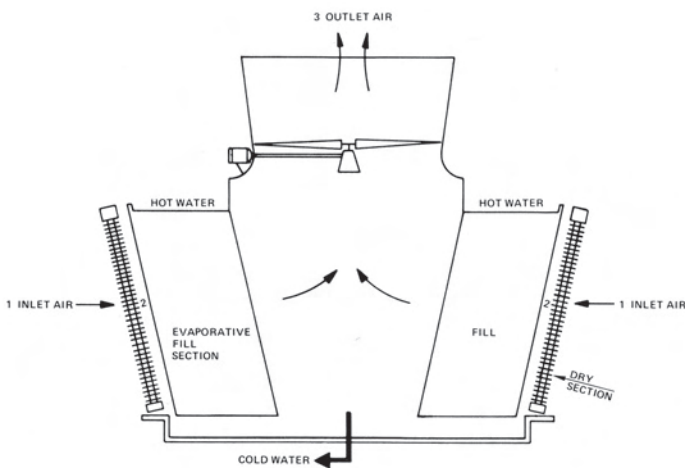
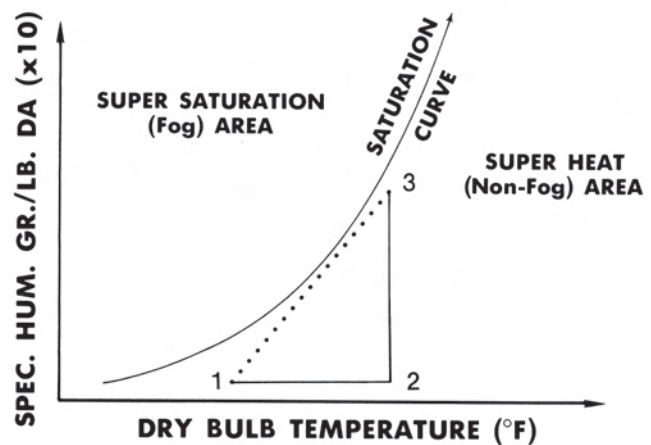

Figure 104 — Series path plume abatement psychrometrics. (Coil before fill)



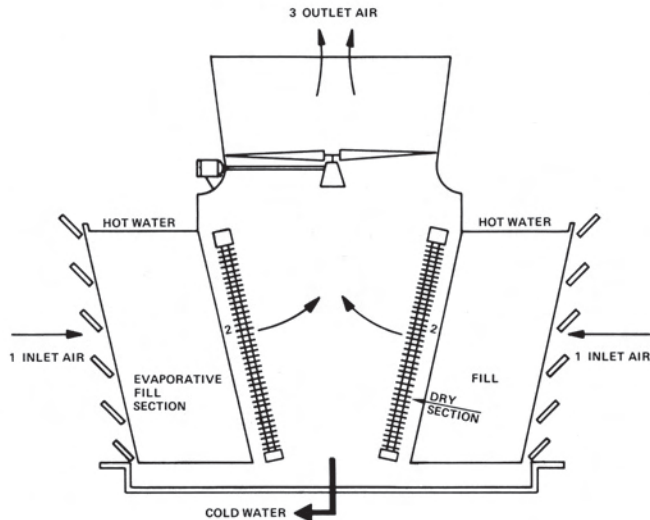
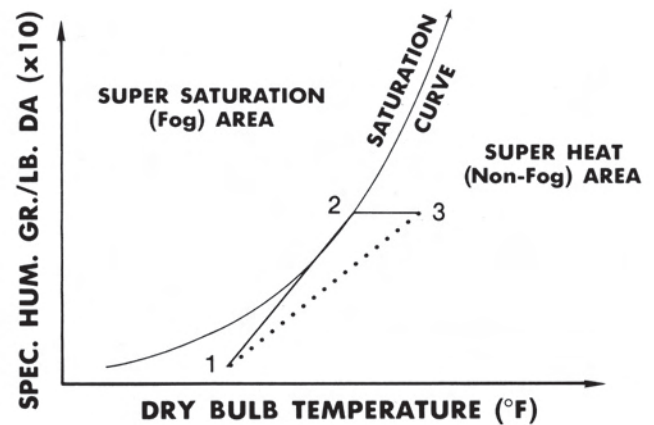

Figure 105 — Series path plume abatement psychrometrics. (Coil after fill)



#### D. ADIABATIC AIR PRECOOLING

Better utilization of a series-path air flow arrangement is depicted in the Figure 106 cross-section, wherein an air cooled heat exchanger with a horizontal tube bundle is located atop the cooling tower, in place of the mechanical equipment normally supplied. The fans of the air cooled heat exchanger induce ambient air first through the fill section of the cooling tower, then across the tube bundle of the heat exchanger, and the entire process heat load is dissipated within the tube bundle.

This ADB Precooler system is designed to provide outlet temperatures lower than those achievable with a standard air cooled heat exchanger by adiabatically precooling the ambient air to a lower dry-bulb temperature.

With no heat added, water recirculated over the fill section will be at a temperature essentially

equal to the wet-bulb temperature of the incoming air. Referring to Figure 18, if ambient air entered the fill section at condition 1, its sensible (dry-bulb) temperature would depress along line 1 - 1' in an attempt to reach the wet-bulb temperature at condition 1'. Although time of contact with the water, among other factors, will prevent total achievement of that goal, 75% of the difference between ambient dry-bulb and wet-bulb temperatures would represent a typical air temperature reduction capability.

Operation of an ADB Precooler system is similar to that of the Water Conservation tower in that the water circuit can be shut off during periods of reduced ambient. Its most effective application occurs in areas of low relative humidity where a significant difference exists between wet-bulb and dry-bulb temperatures of the ambient air.

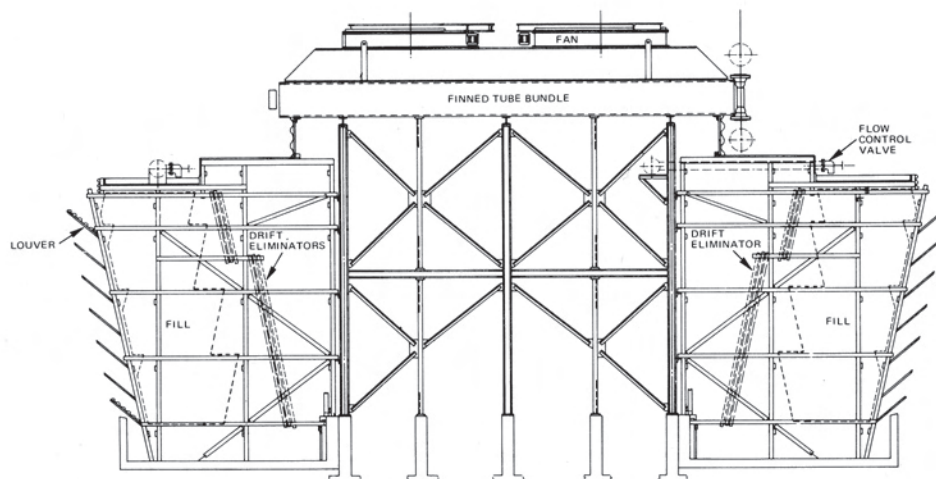

Figure 106 — Cross-section showing evaporative portion of a crossflow cooling tower used as adiabatic air-precooler for an air-cooled heat exchanger.



## E. ENERGY REDUCTION

In the operation of a cooling tower, energy is consumed in driving the fans (unless the tower is natural draft) and in pumping the water. Fan power consumption is treated in Section III-B. Pump power consumption can be calculated by the following formula:

$$\text{Pump bhp} = \frac{\text{gpm} \times \text{TDH} \times \text{s} \times 8.33}{33,000 \times E_p} \quad (15)$$

And the portion of total pumping power attributable to the cooling tower is determined by:

$$\text{bhp} = \frac{\text{gpm} \times H_t \times \text{s} \times 8.33}{33,000 \times E_p} \quad (16)$$

Where:

bhp	= Brake horsepower at the pump input shaft.
gpm	= Circulating water rate in gallons per minute.
$H_t$	= Head loss attributable to the cooling tower; feet of water.
TDH	= Total dynamic head loss in circulating water system; ft. $H_2O$ .
s	= Specific gravity of fluid pumped. (can be considered = 1 for water, although varies slightly with temperature.)
8.33	= Pounds per gallon of water.
33,000	= Foot-pounds per minute per horsepower, by definition
$E_p$	= Pump efficiency.

The portion of the total dynamic head contributed by a cooling tower consists of the static lift measured from the operating water level in the cold water basin to the center of the distribution inlet header; plus pressure required to effect proper distribution of the water to the fill (i.e. a pressure spray system); plus frictional and velocity losses in the riser, header and internal distribution system; less any recovery that may be effected by downturned elbows or valves.

However, the datum from which static lift is measured, as well as the losses incurred in the riser are usually in question. Typically, pump head values indicated in proposals are related to the elevation of the basin curb. To that figure, the user should add the dimension below curb level at which the normal operating water level will be maintained. Also, the total value indicated for cooling tower pump head usually reflects the manufacturer's scope of supply. If the riser is not part of the cooling tower contract, the frictional and velocity-related losses incurred in the riser are not normally included in the total. Static lift, however, should always be included. Since there is room for misunderstanding in a proposal definition of pump head, the purchaser should always determine the missing ingredients, if any, that would contribute to total pump head.

Given no specification instructions regarding the desirability of reducing fan power and pump head,

the cooling tower manufacturer responding to an inquiry will typically offer the selection which results in the lowest first cost. Such a selection may require an excessively high pump head. Almost invariably, it will reflect the highest air rate (and fan horsepower) permitted by good engineering practice. This is because the fan systems required to produce higher air rates are less expensive than the additional structure and fill necessary to thermally compensate for a lower air rate.

Because of the increasingly high cost of energy, extrapolated over amortized plant life, it has become common practice for specifiers to apply a value representing the cost of fan operation (dollars per hp) and pump operation (dollars per foot of pump head) to the total first cost of an offering, in order to obtain an "evaluated" total cost for comparison to other bidders. (Other inputs related to total evaluation are covered in Section VIII-D). These values require the manufacturer to assess a number of selections in varying pump head and fan power requirements in an effort to determine the offering that will result in the best evaluated cost. In many cases, both the lowest "first cost" selection and the lowest "evaluated cost" selection will be offered for the user's choice. The important point is that ***the manufacturer must be made aware of the evaluation values for pump head and fan power in order to arrive at the best overall selection.***

## F. ENERGY MANAGEMENT AND TEMPERATURE CONTROL

As previously seen in Figure 25, the cold water temperature from a cooling tower reduces with any declination in wet-bulb temperature or heat load, assuming continued full-fan operation and constant pumping rate. Many processes benefit from reduced water temperature, with product output or process efficiency increasing with colder water temperatures, offering little incentive for the user to operate the tower at anything less than full capacity. On the other hand, there are any number of processes where cold water temperatures below a certain level are either non-rewarding or, in some cases, actually harmful to the process. Those situations offer the opportunity for significant energy cost savings, brought about by proper operation of the tower.

Cooling tower water distribution systems, whether spray-type or gravity-type, are calculated to produce maximum efficiency within a relatively narrow range of flow rates. Appreciably high flows produce either overpressuring of spray systems or overflowing of open hot water basins. Significantly lower flows produce inadequate water coverage on the fill, which not only disrupts heat transfer efficiency, but also increases the work load of the fan(s). Consequently, primary ***energy management*** in mechanical draft cooling towers should be limited to air-side control, usually accomplished by fan manipulation.

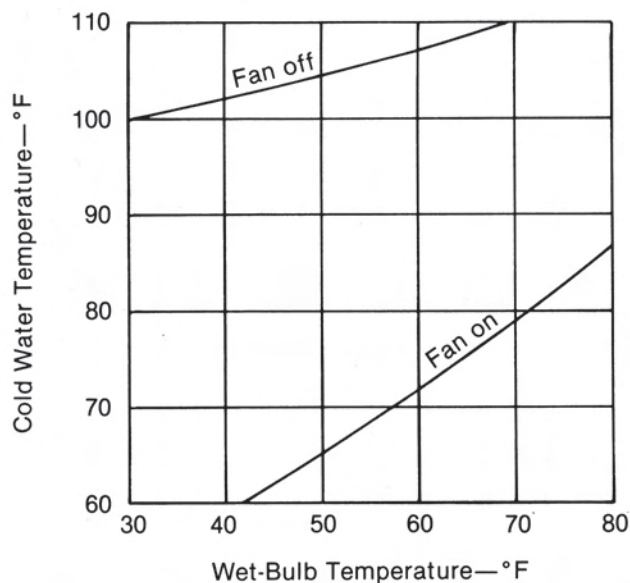

Figure 107 — Typical performance curve. Single-cell tower with single-speed motor.

In most cases air-side control depends primarily upon the number of cells comprising the tower, as well as the speed-change characteristics of the motors driving the fans. Figure 107 defines the operating modes available with a single cell tower equipped with a single-speed motor. In this most rudimentary of cases, the fan motor can only be cycled on and off for attempted control of the cold water temperature, and great care must be exercised to prevent an excessive number of starts from burning out the motor. (Sect. IV-D)

Because of this possibility, many operators find it necessary to incorporate a modulating hot water by-pass system, as shown in Figure 108. With this system, the fan is allowed to continue to run for a specific period even though the tower is producing colder water than is required by the process.

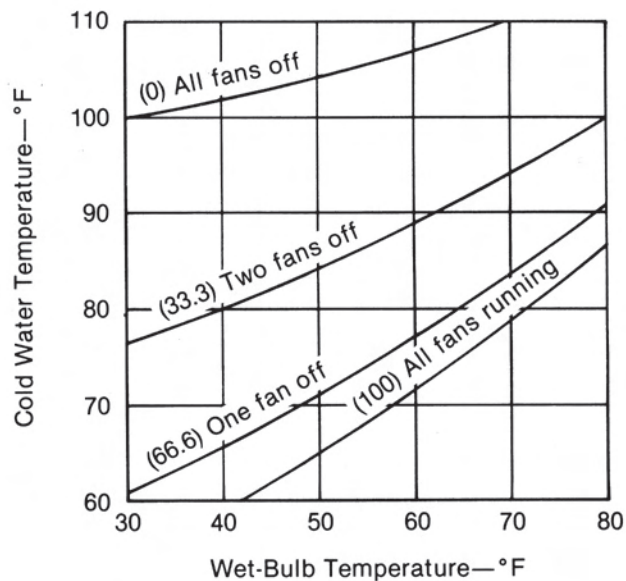

Figure 109 — Typical performance curve. Three-cell tower with single-speed motors.

At a predetermined cold water temperature to the process, the by-pass valve will open sufficiently to introduce hot water into the cold water line (or directly into the cold water basin), thereby elevating the cold water temperature to a level acceptable to the process.

It should be recognized that such by-pass systems contribute nothing to good energy management. They are utilized only to accomplish greater control of cold water temperatures, and to avoid "short cycling" of single-speed motors. Furthermore, **the use of modulating by-pass systems is not recommended for towers operated during freezing weather.** In such situations, the control flexibility afforded by multi-cell towers, and/or two-speed motors, should be considered a minimum mandatory requirement.

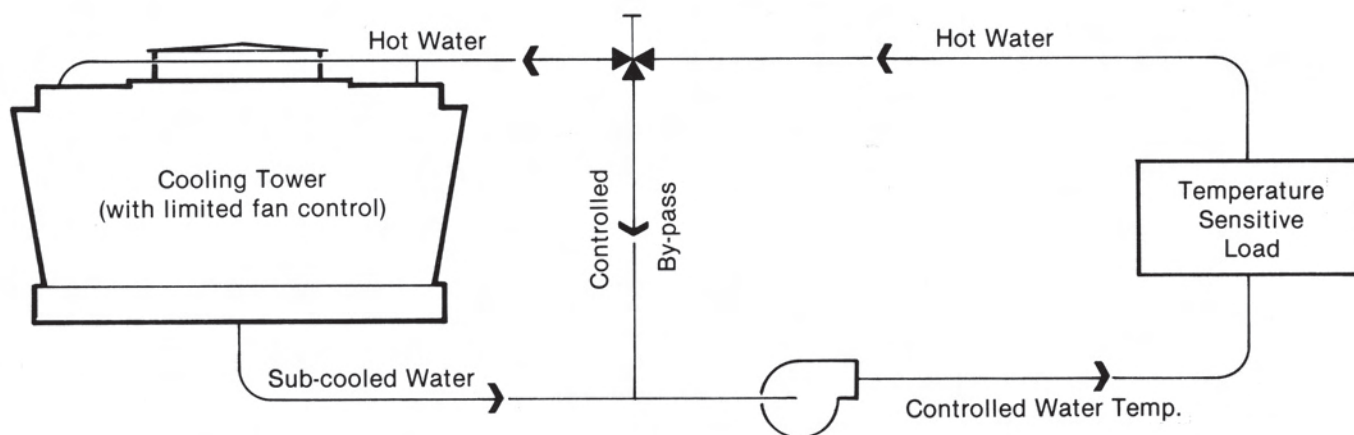

Figure 108 — By-pass arrangement to maintain acceptable water temperature to load.

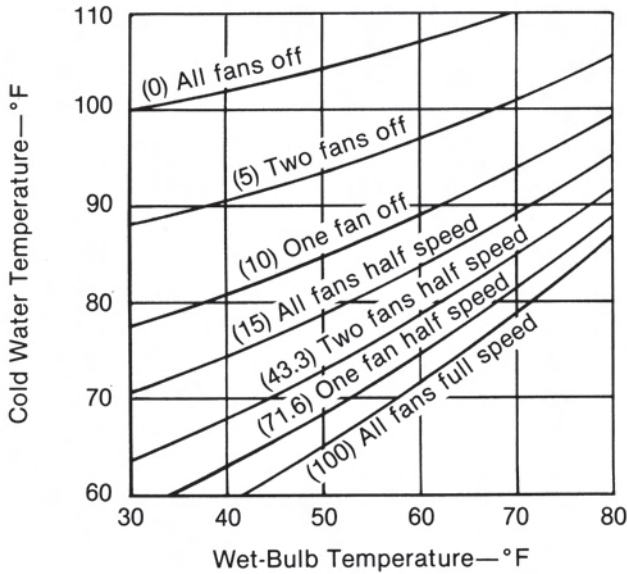

Figure 110 — Typical performance curve. Three-cell tower with two-speed motors.

The operating characteristics of a three-cell tower are indicated in Figures 109 and 110, equipped with single-speed and two-speed motors respectively. The numbers in parentheses represent the approximate percentage of total fan power consumed in each operating mode. Note that the opportunity for both temperature control and energy management is tremendously enhanced by the use of two-speed motors.

At any selected cold water temperature, it can be seen that an increase in the number of fan/speed combinations causes the operational mode lines to become closer together. It follows, therefore, that the capability to modulate a fan's speed or capacity (within the range from zero to 100 percent) would represent the ultimate in temperature control and energy management. The technology by which to

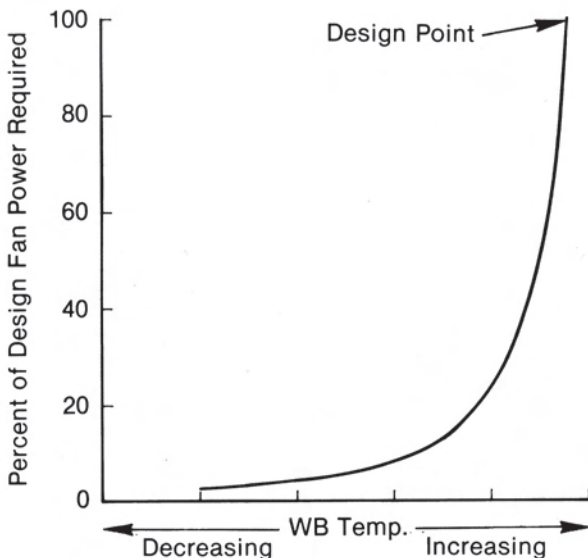

Figure 111 — Fan power required for a constant CW temperature in a changing ambient.

approach this ideal situation currently exists in the form of Automatic Variable-Pitch fans. (Section III-B-2 & 4) Operating at constant speed, these fans do not threaten motor life as cycling does. Set to maintain a constant water temperature, they also return quick energy savings with relatively minor reductions in wet-bulb temperatures. (Fig. 111)

**G. NOISE CONTROL**

Sound is energy transmitted through the atmosphere in the form of pressure waves. The measurement of these sound pressure levels (SPL or Lp) is expressed in terms of decibels (dB). Being of a wave form, sound also has a frequency characteristic which is expressed in Hertz (cycles per second). Knowing sound pressure levels and frequencies, the character of a given sound may be analyzed.

For broad quantification, an "overall" sound level that summarizes the sound pressure levels throughout the range of frequencies may be used. This overall measurement is commonly converted to an A-scale weighted level (dBA), which represents the human ear's perception of the measured sound level. The A-weighted sound level has been adopted as a means of checking compliance with many ordinances and regulations. Because this overall reading is only a general description of the sound level, however, its utility is limited when a more detailed analysis is required.

In order to identify and evaluate an objectionable component of a broad band of sound, the sound pressure levels at various frequencies must be known. To facilitate this, the human-sensitive sound spectrum has arbitrarily been divided into eight frequency bands, called "octaves". These bands have center frequencies of 63, 125, 250, 500, 1000, 2000, 4000, and 8000 Hertz. The instrument utilized to measure the sound pressure levels within these specific bands is known as an Octave Band Analyzer.

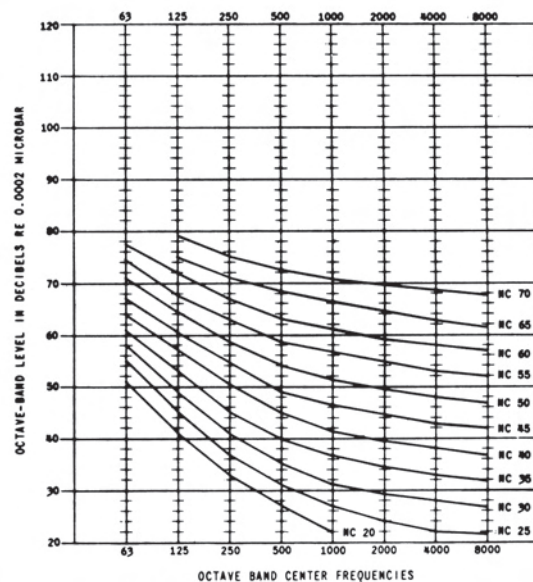

Figure 112 — Noise Criterion (NC) Curves.

To evaluate information obtained with the Octave Band Analyzer, it was necessary to develop standards for comparison purposes. These standards are in the form of "Noise Criterion" (NC) curves (Fig. 112) and related tables (Sect. IX, Tables 5 & 6), which establish recommended sound pressure levels for various indoor conditions. They may be used not only as a means of analyzing existing sound conditions, but also as a datum for specifying sound pressure levels for new installations.

The maintenance of low sound pressure levels is becoming increasingly important on cooling tower installations, particularly in the commercial field. The establishment of suburban office complexes, the location of shopping centers within residential areas, and a generally increasing concern for human comfort and well being, all contribute to the necessity for providing an acceptably quiet installation.

"Noise" is objectionable sound. It is both intangible and relative. A sound pressure level that may irritate one person can be quite acceptable to others. However, as any user who has experienced a noise complaint knows, the irritated few can become very vociferous, and their cries are usually heard. It is necessary for the Owner to have an awareness of any potential noise problem if he is to prevent it from materializing. This may require an environmental analysis of the proposed site in order to determine the acceptable sound pressure level at a potential source of complaint, as well as a tower's maximum allowable contribution to that level.

Sound generated by a cooling tower compiles from the energies expended by the motors, the

speed reduction or power transmission units, the fans, and the cascading water, all of which combine to produce a typical sound level of 70 dBA at a horizontal distance of 50 feet from the louvered face of the tower. This sound level is somewhat less at an equal distance from the cased face due to the water noise being masked. The sound level will diminish with distance, losing approximately 5 dBA each time the distance is doubled. It can also be attenuated by locating the cooling tower such that a substantial structure or barrier exists between the tower and the potential source of complaint.

Fortunately, since sound is a manifestation of consumed energy, the same parameters that result in an energy efficient tower also produce a tower with reduced noise generating capability. Equipping a tower with two-speed motors can effect a periodic reduction in noise output for the time that the fans are operated at half-speed. Depending upon the degree to which the fans are loaded at full-speed, half-speed operation can reduce noise output by from 6 to 10 dBA, or more. Similarly, an oversized tower designed for reduced fan speed and power will generate significantly less noise.

For extreme conditions, where a change of tower location and/or reduced fan speed is not feasible, externally mounted sound attenuators can be added to the tower. (Fig. 113) However, because such treatment is expensive, compounded by the fact that the tower must be oversized in order to compensate for air losses within the attenuators, all possible consideration should first be given to other means of solving noise problems.

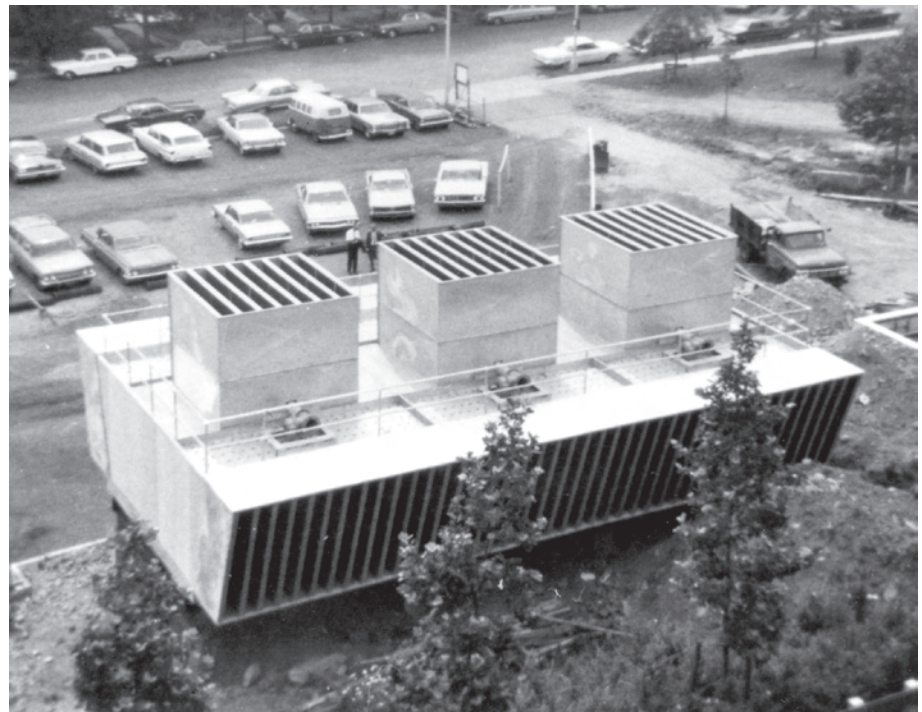

Figure 113 — Tower equipped with inlet and outlet sound attenuation.

## H. DRIFT REDUCTION

As discussed previously (Sect. II-I), drift constitutes a very small percentage of the total effluent air stream from the tower. In most cases, the normal amount of drift exiting modern towers is not considered to be of environmental concern, nor does it produce the aggravating housekeeping problems that may have been encountered with towers of more ancient vintage.

Even this small amount of drift, however, can be considered a problem under certain sensitive circumstances. Since the coloration and chemical content of drift droplets are the same as that of the water circulating over the tower, long term exposure of nearby structures or vegetation to these droplets can have a cumulatively degenerative effect, most predominantly in areas of limited rainfall. Also, during cold weather operation, drift droplets can contribute to any icing problem that may exist downwind of the tower.

Depending upon the size and design of the tower, and the severity of the problem, several techniques can be utilized to minimize drift, most of which are typified by the Figure 114 cross-section of a round mechanical draft, crossflow cooling tower.

– More sophisticated eliminators having increased

impingement area, greater labyrinth, and better drainage capability can be used. (This may have the effect of increasing fan horsepower requirements.)

- Structural penetration of the eliminators can be sealed to prevent the escape of water through random gaps. In the case of the Figure 114 tower, structural penetration of the eliminators has been eliminated entirely.
- Spacing between fill and eliminators can be increased to allow time for the larger droplets to “fall out” before then can impinge on the eliminators. In crossflow towers, this may require an increase in the overall width. In counterflow towers, this may necessitate greater tower height.

Because of the special modifications required to further reduce an already low drift rate, arbitrary specification of an unnecessarily low level of drift should be avoided.

## I. ABNORMAL OPERATION CONDITIONS

“Standard” cooling towers are manufactured of a number of base materials, with various component materials covering virtually the full gamut of possibilities. Each material must exhibit good strength and durability characteristics under normal operating conditions, but it should be understood that

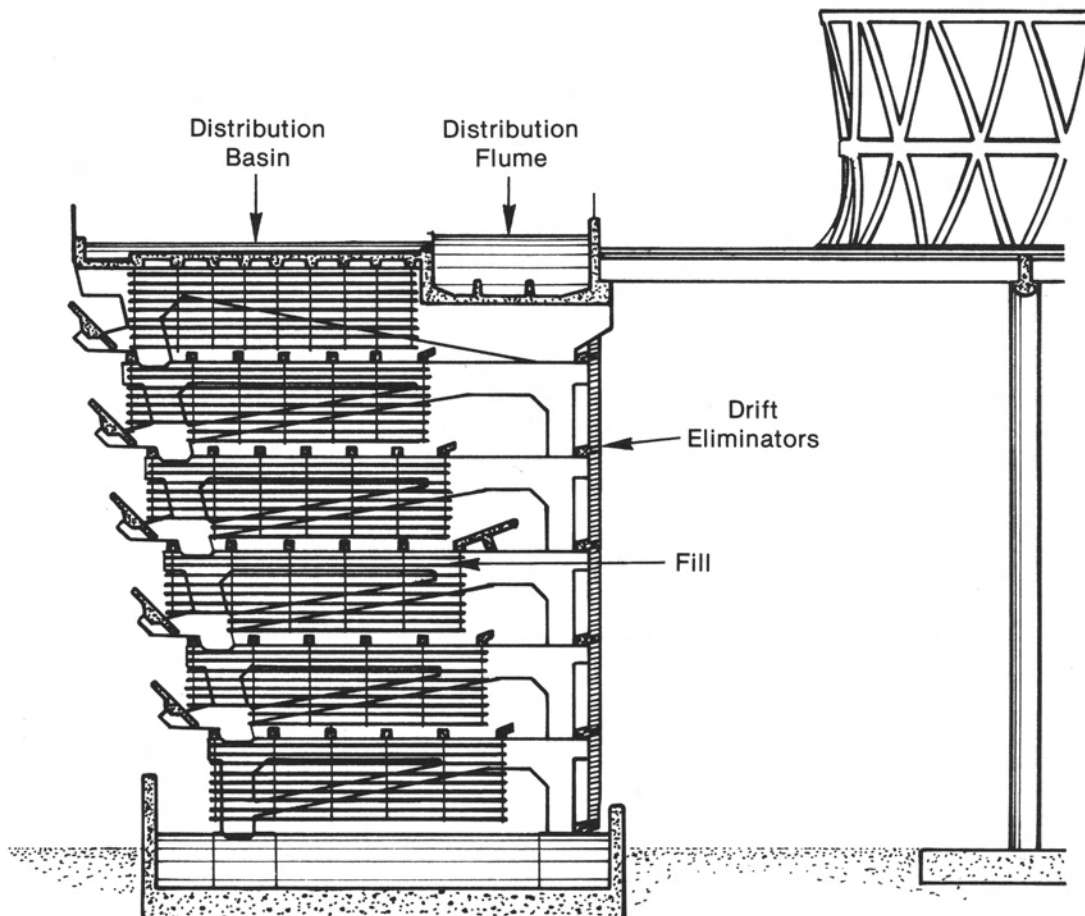

Figure 114

some materials are more susceptible than others to the effects of high temperature, corrosive water or atmosphere, and excessive turbidity. Those and other conditions, along with their effects upon tower design and/or operation, will be discussed under this topic.

1. **High water temperatures**, ranging to 170°F or more, are occasionally encountered in some processes, particularly where batch cooling is involved. At these temperature levels, virtually every material normally used in cooling tower construction becomes adversely affected to some extent. Wood members begin to delignify and lose structural strength, and all but the most sophisticated reinforced plastics will become undependable. Furthermore, because oxidation accelerates with temperature, steel items will be subjected to severe corrosion.

Water temperatures, of course, diminish as the water flows through the tower, with the hot water distribution system, the upper portion of the fill, the top structure and casing, and portions of the fan deck being subjected to the most critical temperatures. Recognizing this, an analytical designer could utilize costly exotic materials in the critical temperature areas, and more standard materials elsewhere, taking great care to match strength and performance characteristics, and to insure that dissimilar metals are insulated from each other.

However, upon further analysis, it is very doubtful that a reputable designer would proceed on such a piecemeal basis. Any future loss of fan power or possible degradation of fill efficiency, could cause the entire tower to be subjected to potentially destructive temperatures. Therefore, the recommendation would be to incorporate

premium materials essentially throughout the tower, making for a relatively expensive installation, and insuring only that the high temperature effect would be retarded.

A much better way to solve the problem is to reduce the water temperature before it arrives at the tower. This is accomplished by the piped by-pass method depicted in Figure 115, wherein the tower is designed to cool more water than the process actually requires, with the excess cold water being diverted back into the hot water piping in order to diminish the inlet flow temperature to the tower. The formula by which to determine the amount of by-pass flow ("B" gpm) is as follows:

$$B = \frac{P \times (H - C)}{(A - C)} - P \quad (17)$$

Where: A = Acceptable incoming water temperature to tower. (°F)

C = Cold water temperature from tower. (°F)

H = Hot water temperature leaving process. (°F)

P = Process Flow rate. (gpm)

For example, let us assume that a particular process requires 1000 gpm to be cooled from 160°F to 90°F, but also that the tower is limited to an incoming hot water temperature of 140°F. Applying these values to Formula (17) we see:

$$B = \frac{1000 \times (160 - 90)}{(140 - 90)} - 1000 = 400 \text{ gpm}$$

Therefore, the tower would be selected to cool 1400 gpm (P + B) from 140°F to 90°F, and 400 gpm would be designed to by-pass the process.

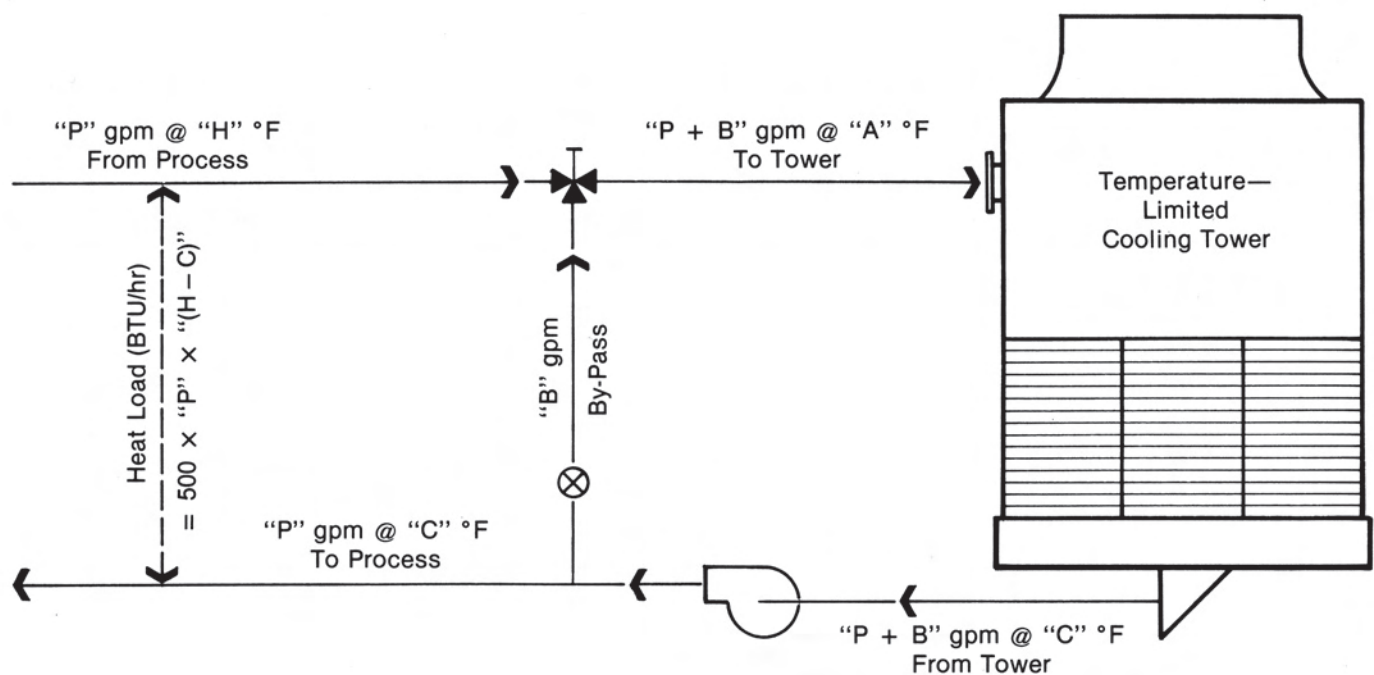

Figure 115 — Piped by-pass arrangement to control hot water temperature to tower.

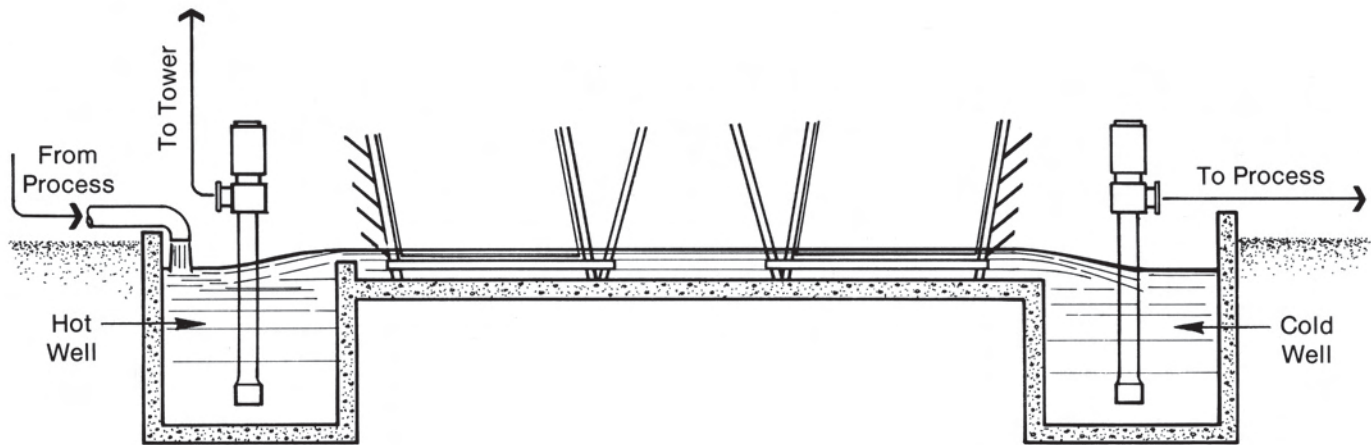

Figure 116 — Wier by-pass arrangement to control hot water temperature to tower.

An alternative method of accomplishing the same net result, occasionally utilized in conjunction with concrete basins, is the hot well, cold well, weir by-pass arrangement shown in Figure 116. Although the hot and cold wells are shown on opposite sides of the basin for clarity, they are usually adjacent to each other. Hot water from the process flows into a separate basin, or pit, where it is mixed with a measured amount of cold water from the cooling tower's basin, usually weir controlled. This combined flow of reduced-temperature water is then delivered to the tower's water distribution system by means of a separate pump. The amount of water to be extracted from the cold water basin for mixing with the process water flow is also calculable from formula (17).

Utilizing either of these methods for limiting incoming hot water temperature causes the tower's cooling "range" (Sect. I-E-4) to decrease which, in turn, causes the required cooling tower size to increase, as indicated by Figure 28. In the example case, instead of being sized for a 70°F range (160 – 90), the tower was sized for a range of 50°F (140 – 90). Therefore, the tower's design range was 71% of what it would have been without by-pass, and Figure 28 shows that this increased the tower size an order of magnitude of 18%. Typically, however, the cost impact of a somewhat larger tower is less than that produced by the combination of premium materials, plus the long term degrading effect of excessively high temperature water.

Because the piped by-pass method (Fig. 115) requires only one system pump, and because it affords more positive control, it is usually the system of choice where control of incoming temperature to the tower is the primary concern.

2. **High turbidity**, depending upon its character and content, can cause thermal and structural problems in a cooling tower, occasionally to the point

of disaster. In its most benign form, it may only increase the frequency of required silt removal from the cold water basin. More aggressive composition, however, may clog water distribution systems, silt-up hot water basins, and obstruct passages in the fill and eliminators. Some forms of turbidity (such as iron oxides and sulfurous compounds) may build up and solidify on any available tower component and place the tower in structural jeopardy.

In many cases, turbidity of the water arriving at the tower can be reduced by the application of a system similar to that shown in Figure 116, except water by-pass from the cold water basin would be required only if high temperatures were involved. Water returning from the process (or from the make-up water supply, if that is the source of turbidity) would flow into one end of a relatively large settling basin, wherein the flow velocity would be sufficiently low to allow particulate matter to settle out, encouraged by a chemical precipitant if necessary. A separate pump, located at the other end of the settling basin, would deliver relatively clean water to the tower's water distribution system.

In the case of particulates whose tendency is to float, they could be skimmed off into an adjacent basin for waste or recovery, by means of either an overflow weir or a floating "skimmer".

Limited ground area availability, among other considerations, often precludes the use of effective settling basins, requiring that the cooling tower be designed to be as impervious as possible to the effects of excessive turbidity. A number of such designs have been developed to solve specific problems, one of which is pictured in Figure 117, and shown in cross-section in Figure 118. The service of this tower is blast furnace cooling at a large steel mill. As can be seen, the tower is spray-fill only (I-B-5), and all of the structural components are either outside the

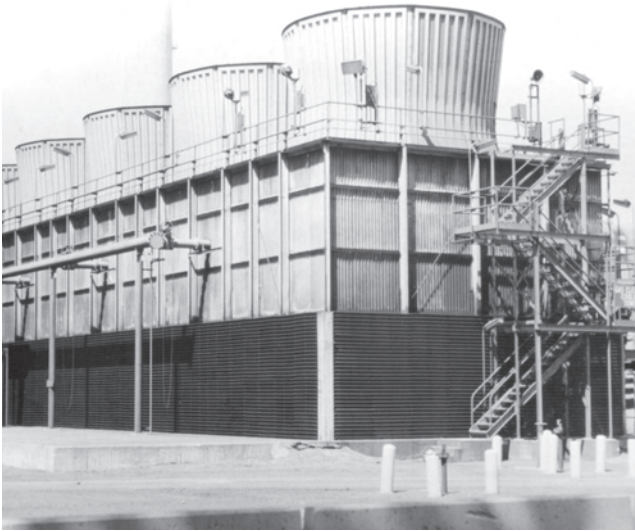

Figure 117 — Special spray-fill counterflow in “dirty water” service.

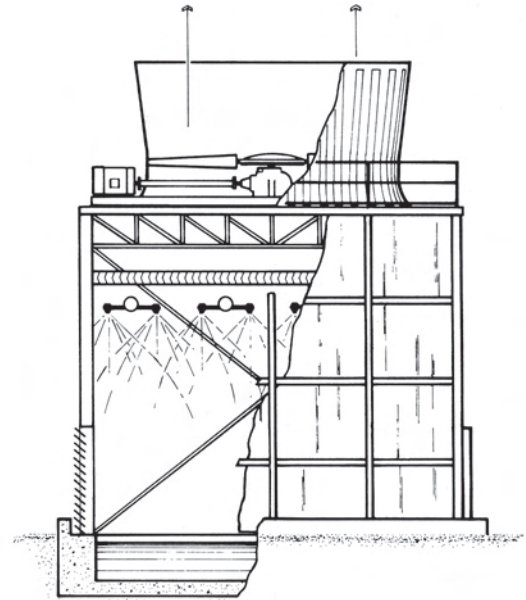

Figure 118 — Cut-away of spray-fill tower in Fig. 117.

casing, or are located above the distribution system. The only exception to this is the interior tie rods necessary for accommodating wind load, on which very little particulate matter has the opportunity to accumulate.

Although these towers are significantly larger than they would be if equipped with fill, it is the very absence of fill which makes them useful to the contaminated water process.

3. **Bacterial slime** can form rapidly on towers where the circulating water is rich in nutrients, ultimately plugging up air passages in the fill and drift eliminators. This bacteriological build-up must be removed from the tower on a regular basis, either chemically, or by means of high pressure streams of water. A type of tower developed to withstand the effects of bacterial slime removal is sketched in Figure 119 and cross-sectioned in Figure 120.

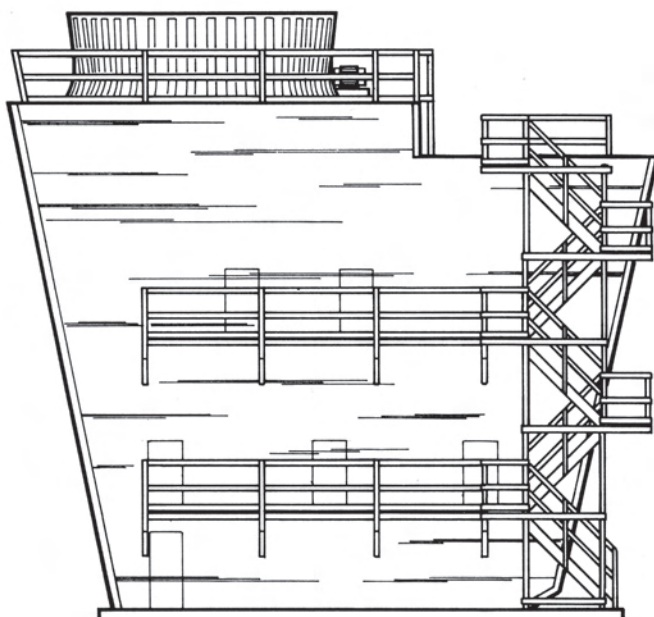

Figure 119 — Special crossflow tower in contaminated water service.

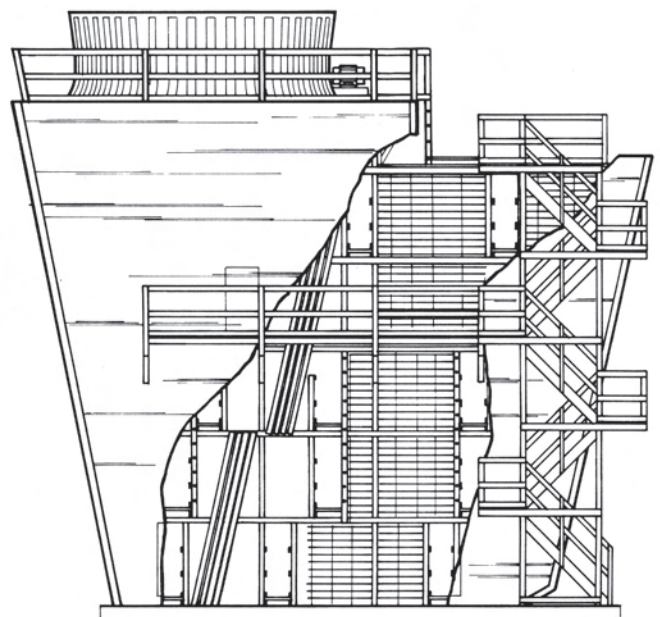

Figure 120 — Cut-away of tower showing maximum access for cleaning.



These towers must be of relatively rugged construction, and equipped with fill of a restrained configuration that will not be disrupted by high velocity streams of water. Walkway "galleries" are provided at the various fill elevations to assure complete access for cleaning of affected areas.

A relatively deep basin is usually constructed, both to serve as a catch basin for the removed debris, and to provide sufficient working room to facilitate its ultimate disposal.

The tower pictured in Figure 119 is operating at a large southeastern chemical plant where the circulating water is contaminated with approximately 6% ethylene glycol. Although there are chemical means by which to suppress slime (Sect. I-G-4), the Owner elected to solve the problem by tower modification.

4. **Salt Water Cooling** by cooling towers has become sufficiently prevalent to no longer be considered "abnormal". However, because its potential for corrosion suggests some deviation from standard construction, it is treated under this topic.

Most of the construction materials utilized in cooling towers (with the exception of metal components) are relatively unaffected by salt water, provided its temperature level and pH value are acceptably maintained. Wood and plastics hold up well, as does good quality concrete. Selected hardware items (such as bolts, nuts & washers) typically change from steel to silicon bronze. Where a change from carbon steel or cast iron is impractical, porcelainization and epoxy-coaltar coatings are utilized for proper erosion and corrosion protection.

The vapor pressure, density and specific heat of salt water differs somewhat from those values assigned to "fresh" water. Although the differences tend to be offsetting with respect to their effect upon thermal performance, salt water towers can be expected to be from 1% to 4% larger than fresh water towers, depending upon the operating temperature levels involved.

5. **Ammonia stripping** by circulating ammonia-laden water over a cooling tower for aeration *is not recommended*. Successful stripping requires an abnormally high pH, which promotes plugging of the fill and eliminators. Furthermore, very little heat load is normally applied, which can lead to destructive ice formations in cold weather operation.
6. **Fatty acids** in the circulating water build up rapidly on cooling tower fill and drift eliminators, requiring that the tower be frequently cleaned. In addition, the presence of fatty acid increases the potential for corrosion and, depending upon its concentration, can adversely affect the tower's thermal performance.

A number of cooling towers are operating successfully on fatty acid service, the majority of which are equipped with wide-spaced, well-

supported plastic splash type fill and premium hardware. Steel towers are normally avoided.

7. **Foodstuffs**: Because of the extensive use of barometric condensers in the food processing industry, various forms of nutritive compounds find their way into the cooling water system; among which are sugars, starches, organic acids, alcohols, and edible oils.

Upset conditions can produce very low pH levels, which accelerate corrosion. These nutrients (particularly sugars, starches and alcohols) promote bacterial growth in the tower, and sugars have been found to attack concrete. The presence of edible oils adversely affects heat transfer and, if routinely anticipated, should be taken into account in sizing the tower.

To the degree that the nutritive contaminants are coagulatory or slime-producing, the cooling tower should be designed to facilitate and withstand frequent cleaning. The use of close-spaced film type fill susceptible to clogging should be avoided, and premium hardware is recommended. Steel towers should not be used.

8. **Hydrocarbons**: In various refining processes, oils, aromatics, and chlorinated hydrocarbons are occasionally leaked into the circulating water system. In many cases, they tend to volatilize within the tower, greatly increasing the possibility of fire. Their presence can also affect thermal performance; attack plastic components; accelerate corrosion; and promote bacterial growth within the tower.

The use of wood towers predominates in the refining industries. Since the introduction of hydrocarbons into the circulating water is not normally anticipated, refinery cooling towers are not usually oversized to compensate for reduced thermal performance. In many cases, however, premium hardware is evaluated and given serious consideration.

9. **Paper Processing** can produce much the same results as food processing in that the wood fibers carried over into the circulating water have nutritive value. Foaming is common, as is the growth of bacteria. Reduced pH is very possible, resulting in accelerated corrosion. The fibrous content promotes clogging of nozzles, fill and eliminator passages, and screens.

Wood crossflow (open distribution basin) cooling towers are normally utilized, equipped with wide-spaced, splash type, cleanable fill, and premium hardware.

10. **Summary**: Of the primary materials from which cooling towers are currently constructed, treated wood has historically proven to be most forgiving of the effects of "bad" water. As projects become larger, however, concrete construction might be expected to come into significant use.

Where contaminants are coagulatory, sediment-forming, fibrous, or slime-producing in nature, crossflow towers with splash type fill are recommended. The cleanability afforded by

open distribution basins, plus the crossflow's adaptability to various types of wide-spaced fill arrangements, make them invaluable in dirty water service. **Close-spaced, film-type fill must never be used for such applications.**

Whether or not chemical water treatment is planned in order to combat the effects of various contaminants, the tower should be designed to facilitate and accept the rigors of cleaning, as well as to withstand the impact of corrosion. Both of which features would be required in a system-upset condition, or at the unforeseen loss of treatment capability.

## J. VIBRATION ISOLATION

The vibration characteristics of a cooling tower are, for the most part, of the simple harmonic wave form since they are derived from the operation of rotating equipment. (Fig. 121) The energy level imparted to the cooling tower and its components by the forces of vibration must be limited by the manufacturer to that which will not adversely affect the operating life of the equipment.

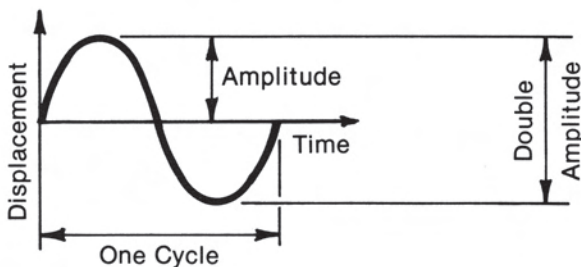

Figure 121 — Displacement vs. time in simple harmonic motion.

Allowable energy levels are usually established by determining a safe allowable double amplitude ( $A_d$ ) of vibration at some common fundamental frequency ( $f$ ), and applying it in the following formula for peak velocity (energy) in simple harmonic motion:

$$v = 2 \times \pi \times f \times A_d / 2 \times \sin 90^\circ = \pi \times f \times A_d \quad (18)$$

Where:  $v$  = Maximum allowable velocity (energy level). Unit: inches per sec.

$f$  = Number of cycles per unit time.  
Unit: cycles per sec. (cps)

$A_d$  = Double amplitude of vibration.  
Unit: inches per cycle.

Customarily, a reference frequency ( $f$ ) of 30 cps (typical of an 1800 rpm motor operating at nominal speed) is chosen, at which point an allowable double amplitude of vibration ( $A_d$ ) of 0.005 inches (5 mils) might be found acceptable. Applying these values in Formula (18) establishes the basic allowable maximum velocity of vibration to be  $3.1416 \times 30 \times 0.005 = 0.471$  inches per second.

Having established an acceptable maximum velocity (energy), Formula (18) can be transposed to solve for allowable double amplitudes at other frequencies found in the normal mechanical equipment of a cooling tower, as follows:

$$A_d = \frac{0.471}{\pi \times f} = \frac{0.150}{f} \quad (19)$$

For an eight-bladed fan turning at 120 rpm, for example, the blade passing frequency would be  $120/60 \times 8 = 16$  cps. At that frequency, the maximum allowable velocity of vibration would not be exceeded if the double amplitude ( $A_d$ ) were  $0.150/16 = 0.009$  inches (9 mils), and the energy level imparted to the cooling tower would be no greater than that represented by a double amplitude of 5 mils at 30 cps.

This is not to say that one should expect a vibration amplitude of 9 mils at the fan blade passing frequency. Normal fan balance usually limits amplitude to about half that amount. On the other hand, one should not be shocked by such a fan-created amplitude but should be able to recognize it as low-frequency-related and, therefore, non-contributory to a potentially reduced service life.

The effect of vibratory forces on anticipated service life notwithstanding, the transmission of vibration, either potential or actual, can be of concern in certain critical situations. Where these situations exist, transmitted vibration can be reduced to acceptable levels by the installation of vibration isolation equipment.

A number of devices and materials are available for use in isolating vibration. Most used for cooling tower applications are springs and synthetic rubber, quite often in combination. Springs offer a wide range of deflection capability, rubber considerably less.

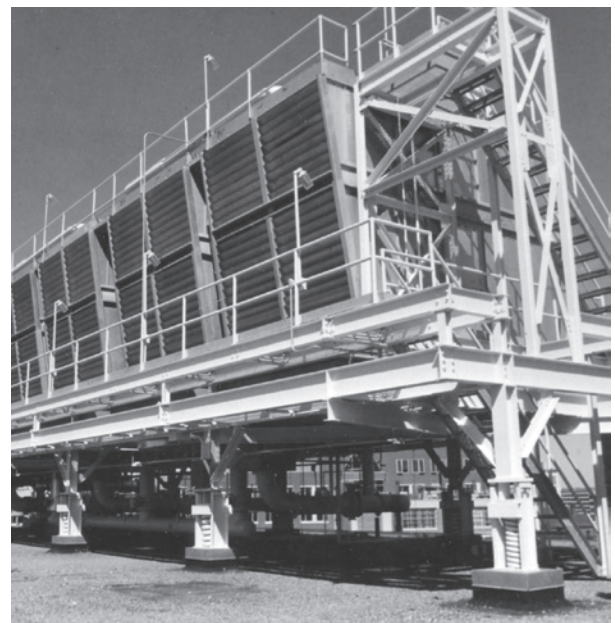

Figure 122 — Tower supported on springs.

Isolators can either be installed under the tower (Fig. 122) or between the mechanical equipment unitized support and the tower structural framework. The former is the preferred method, serving to isolate vibration originating throughout the cooling tower structure, whereas the latter method tends to isolate only the vibration occurring at tower mechanical equipment operating frequencies. When isolating the entire tower, all pipe, conduits, and other components solidly connected to the tower must have vibration damping capability.

Vibration isolation systems are rated in terms of efficiency or transmissibility. Efficiency is the percentage of the vibration force prevented from being transmitted. (Fig. 123) Transmissibility is the percentage actually transmitted. For a specific isolation system and deflection, isolation efficiency increases with the frequency of the disturbance. Thus, if the vibration isolation system for a given machine is designed for the lowest disturbing frequency at an acceptable efficiency, the isolation efficiency for higher speed elements in the same machine will be greater.

In a cooling tower, disturbing frequencies can exist due to the motor speed, drive shaft speed, fan speed, blade passing frequency, and their respective harmonics. Generally speaking, an isolation efficiency of 80% at motor rotation frequency will provide an acceptable degree of isolation in critical situations.

The need for vibration isolation is not governed by any precise criteria for determining "critical" areas. Roof installations on office buildings, hospitals, laboratories, hotels, apartment buildings, and studios

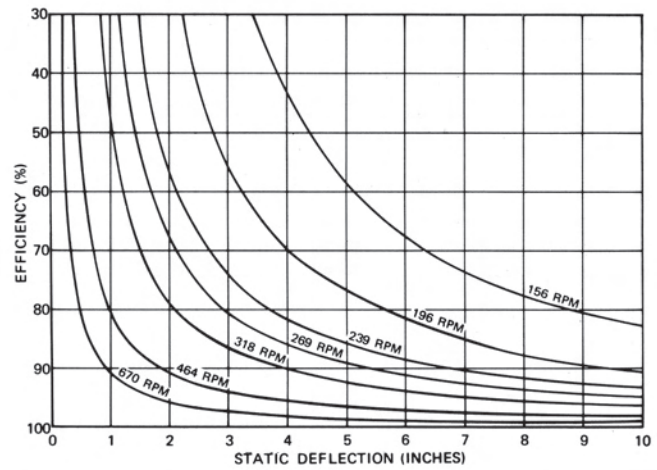

Figure 123 — Effect of spring deflection on isolation efficiency at various fan speeds.

all require a careful study relative to their proximity to occupied space. Under certain conditions, any of these may be classified as critical areas. Conversely, towers installed at grade or in industrial areas are seldom candidates for isolation.

Good judgment is required on the part of the Owner/engineer in evaluating the potential for vibration annoyance. Tower placement in a "non-critical" area is the obvious answer. Circumstances preventing this, vibration isolation should be specified at the minimum efficiency to accomplish the desired results.

## K. FREE COOLING

All air conditioning systems, and many processes, require much colder water than a cooling tower is capable of producing at summertime design atmospheric conditions. In those cases, a chiller of some type is designed into the cooling water circuit to provide water at an acceptably depressed temperature.

Shown in Figure 124 are the typical water circuits for a tower-chiller-load combination. In the diagrammed case, the load is assumed to be air conditioning. Note that the chilled water pump (CHWP) circuit delivers water to the "load" at a temperature unachievable by the cooling tower under summertime conditions. The chilled water, somewhat elevated in temperature, then returns to the chiller where its load is transferred to the condenser water pump (CWP) circuit.

Note also that the load delivered to the condenser water circuit and cooling tower is somewhat higher than the actual load imposed by the air conditioning system or process. This is because of the added work necessary to achieve the chilling process. In the case of the refrigerant compression system shown, the load is increased by a factor of 1.25 (15000/12000 Btu/hr/ton), representing the added heat of compression. If the chiller were of the absorption type, the load would be increased by a factor of 2.5, representing the added heat of steam condensing.

The temperatures to and from the load, indicated for the chilled water circuit, are typical of those required in order to achieve both cooling and dehumidification in an air conditioning system operating in the summertime. Cold water temperatures required for a process are normally expected to be somewhat higher, more on the order of 60°F to 75°F. The required cold water temperature level takes on significant importance in the proper application of a tower on a "free cooling" cycle.

The opportunity for free cooling begins to occur in the fall of the year, carrying through to spring. It occurs because of the normal reduction in a cooling tower's cold water temperature brought about by a depression in wet-bulb temperature and/or load. (Fig. 25 or 107) In most localities, there will come a period during the course of the year when the ambient wet-bulb temperature will have sufficiently depressed to permit the cooling tower to produce a cold water temperature previously achievable only by the chiller. With a properly arranged system, the cooling tower water can then be re-circuited to directly serve the load; thereby obviating the use of the most energy-intensive piece of equipment in the cooling water system – the chiller.

Several arrangements by which free cooling can be accomplished are possible, all of which are well documented in manufacturers' literature. The two most basic methods will be discussed herein, as follows:

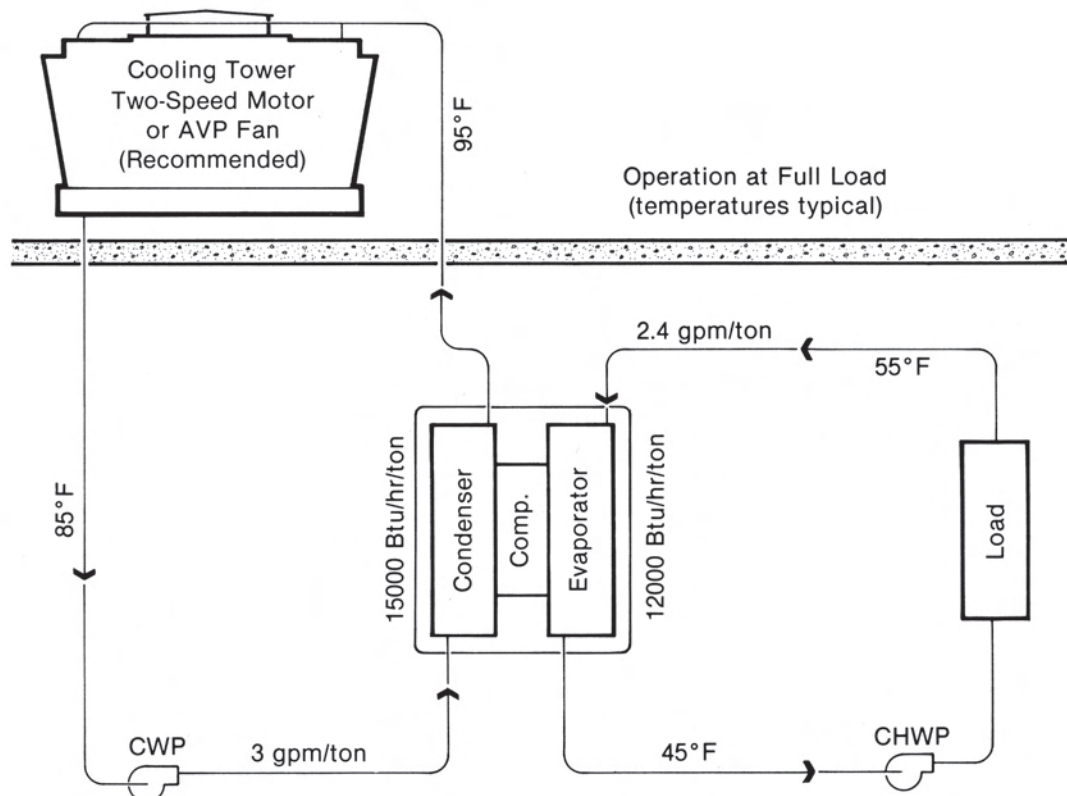

Figure 124 — Schematic of water circuitry in typical air conditioning system.

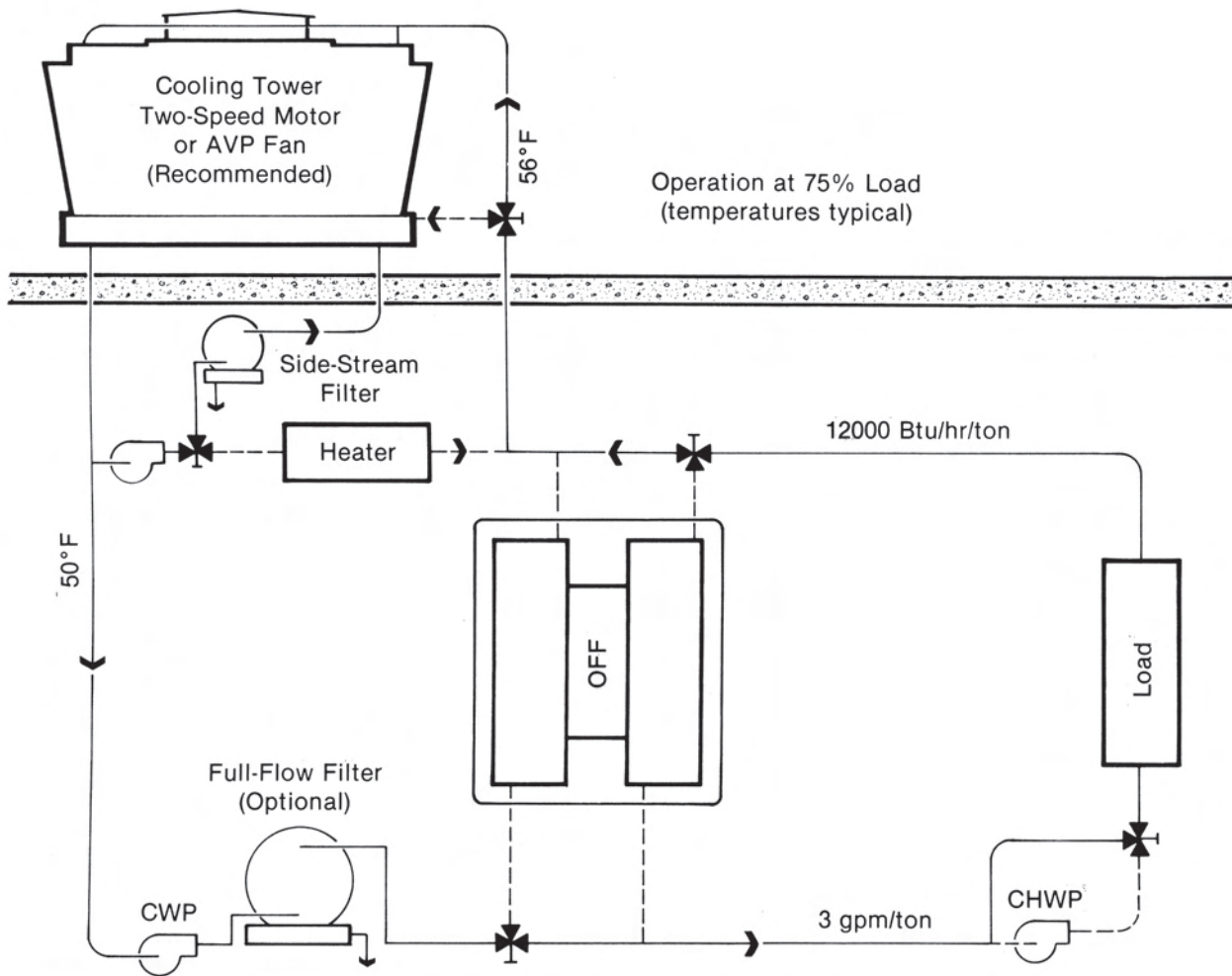

Figure 125 — Schematic of water circuitry in "direct" free cooling system.

1. **Direct Free Cooling:** By adding valved by-passes and interconnecting piping to the basic system indicated in Figure 124, the system shown in Figure 125 is achieved. Water from the cooling tower flows directly to the load and back to the tower, by-passing the chiller completely. Several notable points, which may require some explanation, are apparent in this diagram:

- Since the previous two water circuits are now common, one of the circulating water pumps must be by-passed. Although good energy management would seem to suggest use of the typically lower power chilled water pump, proper winter operation of the cooling tower (Sect. I-H) dictates that the higher flow capability of the condenser water pump be utilized.
- The water temperature going to the load has increased considerably becoming more in line with the temperature that might be expected for a process. This is because off-season air conditioning loads include drastically less dehumidification than is required in summertime. Furthermore, the higher temperature water

will easily accommodate any residual cooling load, and will do so at a temperature much more compatible with the heating required in many zones of the building.

- The water temperature rise across the load has reduced. This happens for two basic reasons: 1) The cooling load will have reduced due to seasonal factors, and 2) the increased quantity of water delivered to the load by virtue of utilizing the condenser water pump permits less temperature rise. (In a process application, the level of relative water temperatures might be expected to remain somewhat more constant year-round.)
- The percent of total load normally contributed by the chiller (compressor) is no longer imposed upon the tower.
- The use of some means of filtration is suggested. This is because the raw cooling tower water circuit is now in a position to "contaminate" the relatively "clean" chilled water circuit. Because of its ability to defeat contamination at the cooling tower basin, which is the primary source, by-pass filtration is recommended. (Sect. VI-E)

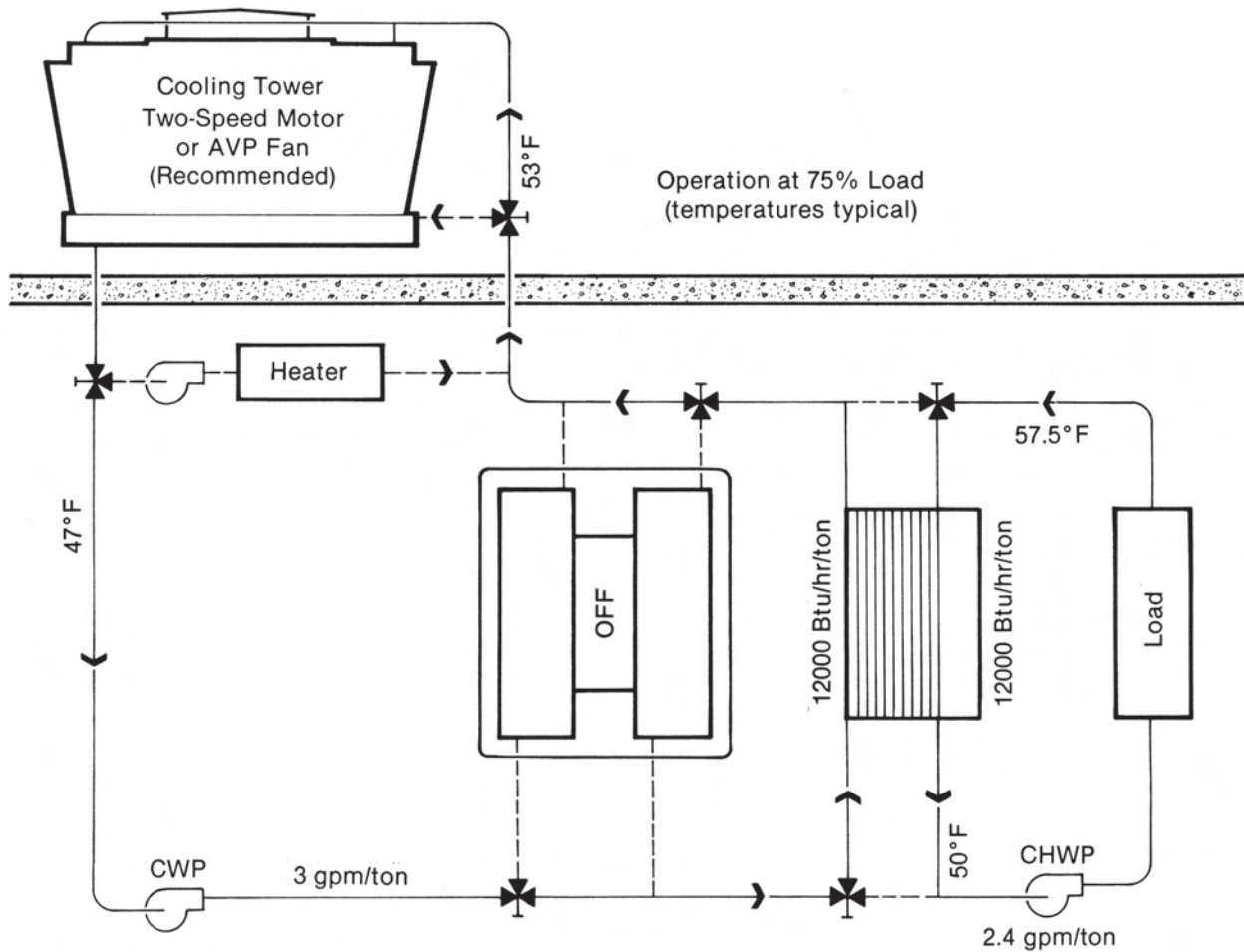

Figure 126 — Schematic of water circuitry in “indirect” free cooling system utilizing plate-type heat exchanger.

- f. To prevent basin freezing during periods of winter shutdown, some means of basin heating is suggested. (Sect. VI-D-5)
  - g. Either two-speed cooling tower fan motors or AVP fans are recommended. Not only does this assist in the prevention of freezing during wintertime operation (Sect. I-F-1), but it also affords a means of improving energy use and controlling cold water temperatures (Sect. V-F) as ambient reduces.
2. **Indirect Free Cooling:** By the inclusion of a simple plate-type heat exchanger, free cooling can be accomplished with total separation of the two water circuits (Fig. 126), which precludes

the water quality control problems inherent in a direct-connected system and is **seen by most operators as a distinct advantage**. Offsetting this is the disadvantage of fewer available hours of operation on the free cooling cycle during the course of a year. This is because of the need for a reasonable temperature differential between the incoming cooling tower water and the leaving “chilled” water at the heat exchanger. Since the cooling tower must produce colder water, it must wait for a further-reduced wet-bulb temperature, and the time interval can sometimes represent a significant number of operating hours.

**L. HELPER TOWERS**

Were it not for environmental regulations which prevent the discharge of elevated-temperature water into natural tributaries in certain localities, plants located near such bodies of water would utilize them as a natural heat sink on a "once-through" basis, thereby avoiding the cost of owning and operating a cooling tower.

"Once-through" utilization of river water is schematically presented in Figure 127 wherein water extracted from the river absorbs heat from the process and returns to the river (at an elevated temperature) downstream of its point of extraction. The temperature rise ( $^{\circ}\text{F}$ ) of this side-stream of cooling water is equivalent to "range", calculable from a simple transposition of Formula (1), Page 22.

Because of the existence of restrictive regulations (both qualitative and quantitative) regarding natural water use, most plants will make use of a "closed-circuit" cooling tower system as portrayed in Figure 128. In this case, the cooling tower is properly sized to dissipate the entire heat load year-round. The system's dependence upon the river is limited to the requirement for a supply of make-up water (II-D-4) and as a point of discharge of blow-down (I-G-1).

In many cases, more analytical operators will utilize the "helper tower" system depicted in Figure 129. In this arrangement, the cooling tower is sized only large enough to reduce the process cooling water effluent temperature to a level acceptable for discharge into the river. In areas of less stringent concern, this usually results in a cooling tower much smaller than would be required to dissipate the full heat load. Furthermore, under certain combinations of heat load and river temperature, the process cooling water effluent temperature may be acceptable to the river, in which case the tower may be shut down and its operating cost avoided. Figure 49 is a photograph of a helper tower whose basin discharges directly into an adjacent tributary.

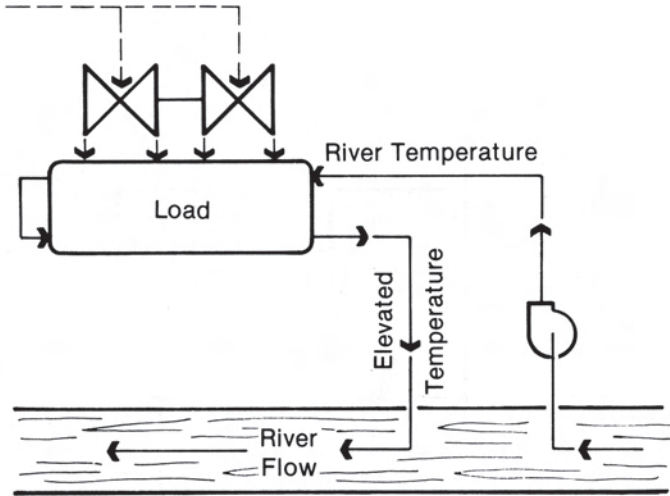

Figure 127 — "Once-through" system. (Entire heat load transferred to river)

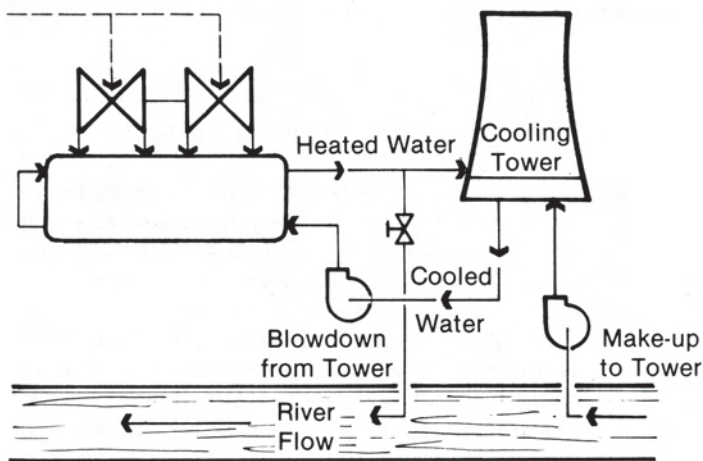

Figure 128 — "Closed circuit" system. (Entire heat load dissipated by cooling tower)

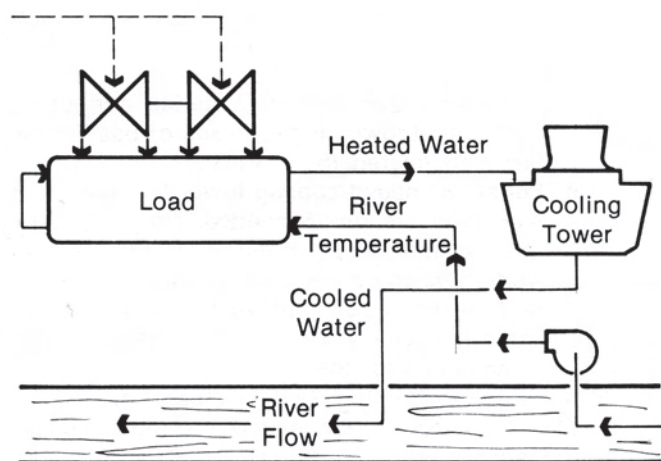

Figure 129 — "Helper tower" system. (Tower removes part of heat load before water returns to river)

## Auxiliary Components

### A. GENERAL

Various devices exist whose purpose is either to protect the cooling tower, or to facilitate its operation, maintenance and repair. Although many of these auxiliary components may be successfully added at a later date, their incorporation at the initial design stage reflects best engineering practice, permitting the designer to include them in a manner most conducive to proper tower operation.

For example, although strategically located walkways, ladders and handrails are normally included on cooling towers of any appreciable size (Fig. 130), their scope and location usually reflects the manufacturer's experience regarding where they are most-needed or most-utilized, and may not totally accommodate the Owner's desires. Specifications should be clear not only as to the required location for walkways, but also as to the reason for them being there. Occasionally, the manufacturer will discourage a particular walkway location because of its potential to adversely affect the operation of the tower.

One such area of concern is within the plenum space below the fan, Geareducer, and driveshaft of the tower. Without doubt, a permanently installed walkway in that location would greatly simplify maintenance and repair of those components. In most cases, however, the air entrance losses to the fan created by such a structure would result in an

intolerable reduction in the tower's thermal performance.

Similarly, knowledge at the specification stage of this requirement for any auxiliary component insures its thoughtful incorporation into the overall cooling tower design.

### B. EXTENDED OIL FILL AND GAUGE LINES

Most Geareducers are designed such that they can be equipped with an oil fill line extending to the outside of the fan cylinder, terminating with an oil level measuring device, conveniently located near the motor. (Fig. 87) The measuring device may consist of either a dip stick, or a sight glass enclosed within a brass body.

On smaller installations, where the Geareducer is reasonably accessible from inside the tower, oil fill and gauge lines are normally offered as optional equipment. Larger towers incorporate them within their standard design, and will also include provision for draining of the Geareducer at the same terminal location.

Specifications which call for a drain line to be extended downward and to the outside of the tower, terminating near its base, are discouraged because any moisture that may find its way into the system will ultimately congregate at that terminal fitting, where either corrosion or freezing can cause failure.



Figure 130 — Ladders, guardrails, and access-ways on a crossflow tower. Note wood stave pipe header (no longer current).



### C. MECHANICAL EQUIPMENT REMOVAL DEVICES

On many large tower installations, light cranes or “cherry pickers” are either not readily available to the Owner, or the space around the tower is too congested to permit their use for the removal and replacement of such relatively heavy components as motors and Geareducers. In recognition of this, manufacturers offer systems similar to the swivel hoist, track and dolly arrangement indicated in Figure 131, whereby the Geareducers can be removed to the fan deck level through a large access door in the fan cylinder. Figure 132 also shows this basic system being utilized to remove a motor.

The removed component can be dollyed to the end of the fan deck, and lowered by means of a properly designed hoisting structure. This structure may consist of an endwall derrick (Fig. 133) or an endwall davit (Fig. 134), depending upon the magnitude of load to be hoisted. These structures are also very useful for hoisting drums of oil and other maintenance materials.

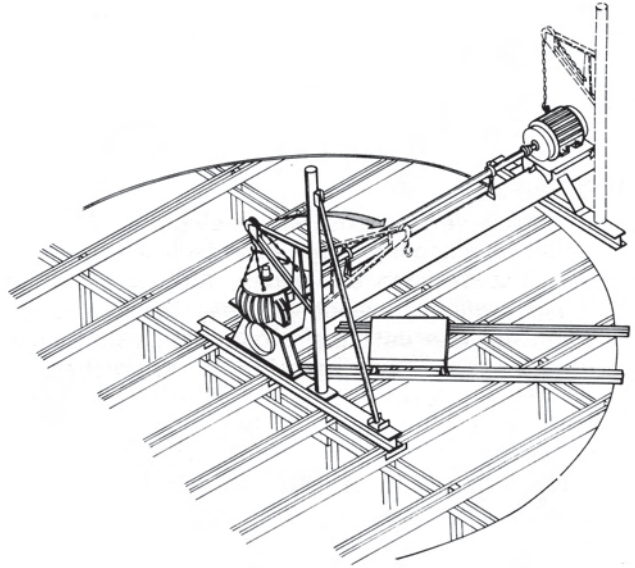

Figure 131 — Diagram of typical mechanical equipment removal system.

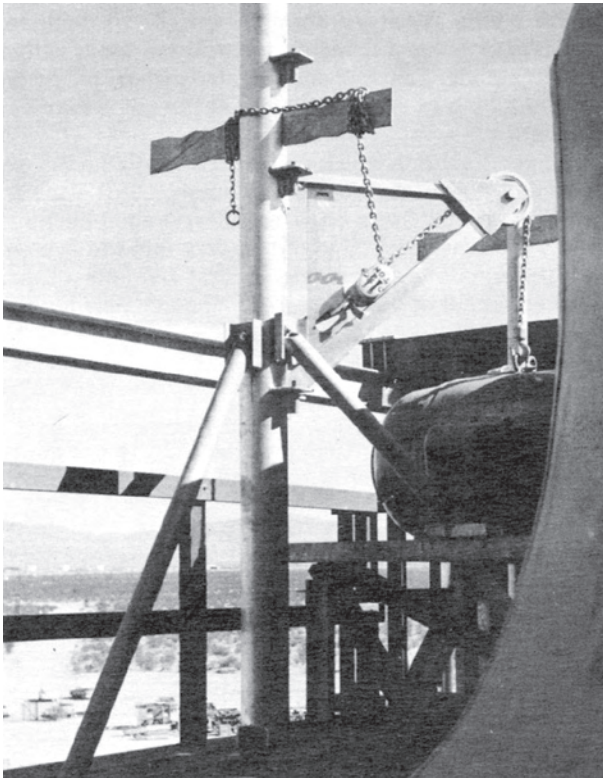

Figure 132 — Specially designed hoist can be used at both motor and fan locations to facilitate service and maintenance.

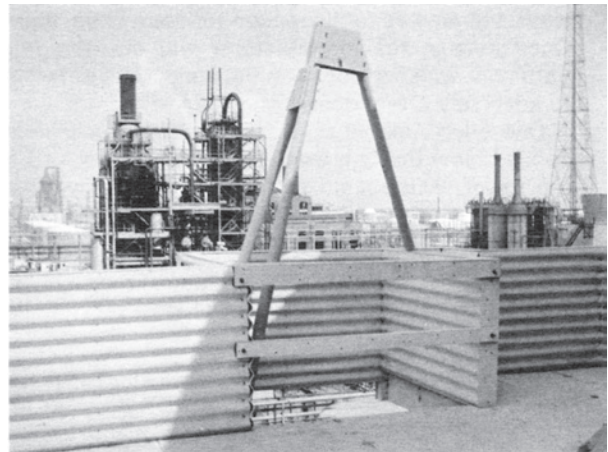

Figure 133 — Endwall derrick used to transport large mechanical equipment between top of tower and grade level.

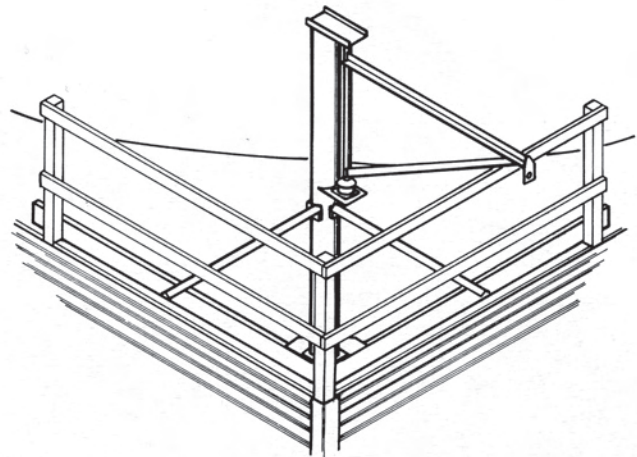

Figure 134 — Towers of intermediate size use endwall davit for servicing and handling mechanical equipment.

## D. PREVENTION OF BASIN FREEZING

Cooling towers are routinely operated year-round on industrial process applications, requiring only sensible vigilance on the part of the operator to prevent the formation of unacceptable ice. (Sect. I-H) Many of these installations, however, go through periods of shutdown (nighttime, weekends, holidays, interims of scheduled or unscheduled maintenance, etc.) during cold weather, at which time the water in the cold water basin, as well as in all exposed piping, becomes subject to freezing.

This situation is particularly prevalent on cooling towers applied to year-round air conditioning or refrigeration loads and, with ever greater utilization of the "free cooling" concept (Sect. V-K), the need to prevent freezing during periods of shutdown is increasing.

The rate at which heat will be lost from the cold water basin of an inoperative tower is the summation of total losses at the water surface, and through the basin bottom and sides, as calculable from Table 7. Basin heat losses are affected by the following:

1. The plan dimensions of the basin. This is used to calculate the water surface, and the areas applicable to the basin bottom and sides as well. (Assume a water level the height of the overflow to determine side losses.)
2. Basin type and exposure. Obviously, an elevated steel basin will lose heat faster than will a concrete basin depressed in grade.
3. Basin water temperature to be maintained. (Control temperature should *not* be set below 40°F.)
4. The ambient air temperature. (The design temperature chosen should be within the lowest 1% level of winter temperatures prevalent at site.)
5. Average wind velocity. The higher the wind velocity, the faster heat will be lost from the basin. (The values indicated in Table 7 assume an average wind velocity of 15 mph. Although this directly affects bottom and side exposed areas, it is recognized that the internal structure, fill, partitions, etc., will have a dampening effect upon the wind. Therefore, water surface losses are based upon an effective wind velocity of 5 mph.)

Except for the fact that there would be no surface exposure, water contained within exposed piping is affected similarly. Table 8 indicates heat loss values for pipes of various diameters, on the assumption that they would be protected by at least 1" of good insulation.

Several effective methods are utilized to prevent freezing during shutdown, among which are the following:

### 1. *System Draining*

This would seem sufficiently obvious to require no further discussion. However, the Owner should be cautioned against relying upon the ability of an operator to anticipate a "cold snap", and to remember to drain the system.

Usually, complete system drainage is limited to very small installations, particularly those on which the cooling tower represents the highest point of the circulating water sys-

tem. Temperature-actuated automatic valves at the point where supply and return lines have entered a heated space could be controlled to drain those lines (thereby the cooling tower basin as well) at a cold water temperature of 40°F. On systems where water will freely back-flow through the pump, only a valve in the cold water line returning from the tower is necessary. The differential head caused by draining the return line should cause the water in the supply line to depress to the level of the drain valve. If there is any question as to this back-flow capability, however, two valves should be used.

Furthermore, the supply line for make-up water to the tower should be similarly valved to prevent flow to the tower when the basin water level is lost, and the exposed portion of the make-up line must either be drained, or traced with electric heating cable.

### 2. *Indoor Tank Method*

This method, sometimes referred to as "dry basin operation", allows water in the tower's cold water basin to drain continuously into an indoor storage tank, as depicted in Figure 135. The small by-pass drain line connecting the main supply and return lines, just below the "roof" level, is there to insure drainage of the tower supply line at the time of pump shutdown. This by-pass line may be equipped with an automatic valve designed to open on pump shutdown, or it may merely be a relatively small open line that would allow a limited amount of warm water to continuously bleed into the tank.

This type of system necessitates a somewhat larger pump than would be required if suction were being taken from the tower's cold water basin. This is because the static lift has increased by an amount equal to the vertical dimension from the top of the tower's cold water basin to the operating water level in the indoor tank.

### 3. *Electric Immersion Heater Method*

Figure 136 depicts the method most utilized on air conditioning, refrigeration, and light industrial installations, whereby an electric heater immersed in the cold water basin replenishes heat lost to ambient. Such systems may be purchased from the cooling tower manufacturer, engineered to suit the specific tower model; or they may be added at some later date by the user. In any case, the system is made up of the following components:

- a. *Electric Immersion Heater*: Two types of immersion heater are used. Where factory preparation is involved, thru-the-side type heaters are normally provided, complete with mounting flanges and gaskets. Add-on installers may also use this type or, if clearances permit, may choose to utilize an over-the-side type to avoid penetration of

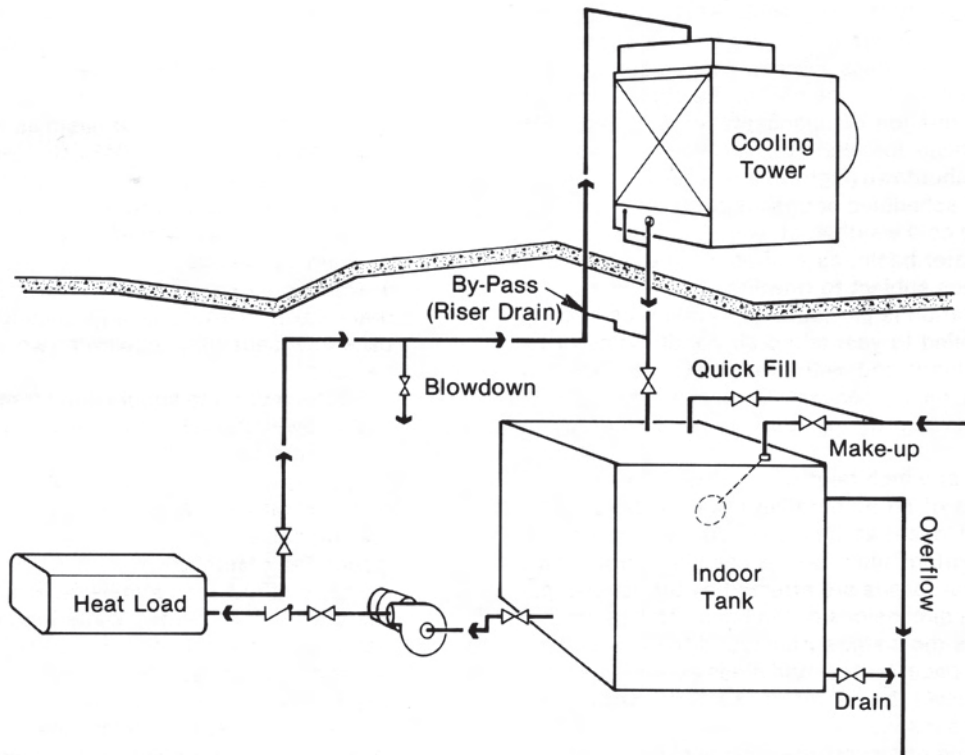

Figure 135 — Use of indoor storage tank simplifies wintertime freeze protection.

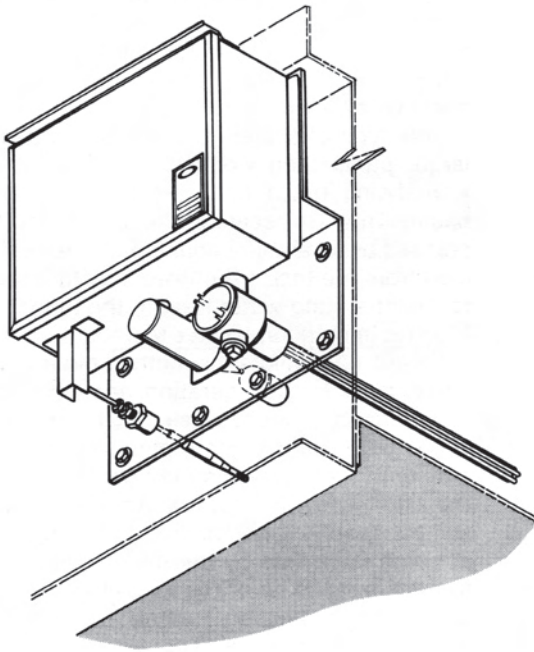

Figure 136 — Electric immersion heater system to prevent basin freezing.

the basin. Metal bracket supports, resting on the floor of the basin, are necessary in order to keep the unsupported length of the heater element under 30 inches.

- b. **Thermostat:** An adjustable thermostat, complete with bulb and capillary, energizes the contactor for the heater element(s) to maintain no less than 40°F basin water temperature.
- c. **Float switch:** Since heater elements op-

erate at about 1520°F in the open air (at which temperature they are capable of initiating fire), it is necessary to assure that they cannot energize with less than adequate water coverage. A float switch wired into the control circuit serves this purpose. An electric probe and relay (Fig. 66) can also be utilized, in lieu of a float switch

- d. **Circuit Breaker:** Necessary to disconnect the main power supply in case of excessive current draw. This could be caused by a short to ground somewhere in the heater, the heater controls, or the wiring.
- e. **Contactors:** Magnetic contactor is used to turn heater(s) on and off. (Thermostat and float switch are used to control contactor.)
- f. **Control Transformer:** Necessary where 120 volts for control circuit is desired, or required by electrical safety code. Circuit breaker, contactor, and control transformer are usually installed in a weatherproof NEMA 3 enclosure attached to the casing of the tower.

Once having determined the potential heat loss from the basin, the proper size of the electric immersion heater may be calculated from the following formula:

$$\text{Heater kW} = \frac{\text{Heat Loss (Btu/hr)}}{3412 \text{ (Btu/hr per kWhr)}} \quad (20)$$

Although the normal convection currents initiated by a heater will protect a square or rectangular area of approximately 300 sq ft, elements should be located in reasonable proximity to the sump or outflow region to

assure an ice-free condition at start-up. For basins of larger size, multiple heaters may be strategically located to operate in parallel. Basins separated by a partition, however, must be equipped with separate heaters and controls to prevent the possibility of water freezing, or a heater element operating in too little water. Where the cold water basins of several cells are connected with flumes, and one contactor-circuit breaker is controlling heaters in all basins, thermostats in outboard cells and alternate intermediate cells should be wired in parallel to control the contactor.

Since the heat added by an immersion heater is local to the cooling tower basin, connected piping which is exposed to outside ambient temperatures must be protected by electric tracer cable and insulation.

**4. Steam Heating Method**

Steam, if available, may be utilized to supply heat to an inoperative basin. It may be injected directly into the basin water through a commercially available steam "muffler", allowing condensate to mix with the basin water, or the condensate may be recovered by the use of a closed pipe "loop" installed in the basin.

Figure 137 indicates the proper pipe factors to be used in the following formula to determine the length of a closed circuit pipe loop:

$$\text{Ft of pipe} = \frac{\text{Heat Loss (Btu/hr)}}{10,000} \times \text{Pipe Factor} \quad (21)$$

The pipe loop should be situated to afford proper protection to the sump or outflow region, and the loop should be slightly sloped to allow condensate drainage. External exposed water piping must be insulated and traced with a source of heat.

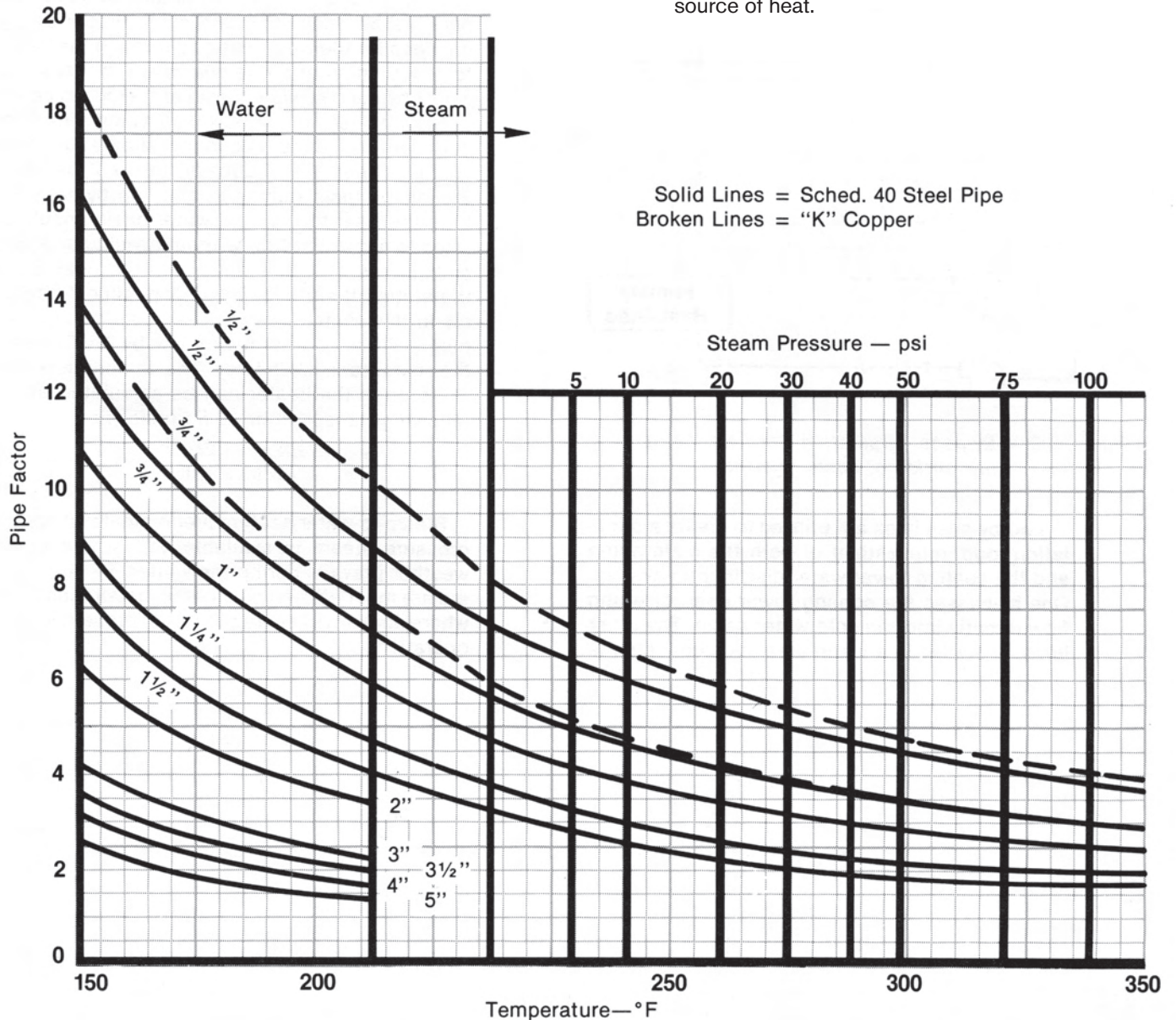

Figure 137 — Pipe factors for basin heating with hot water or steam coils.

### 5. By-Pass Circulation Method

The by-pass circulation method of cold weather basin protection is one of the better schemes for any installation, regardless of size, because it protects not only the cooling tower basin, but the exposed piping as well. Figure 138 shows the necessary components and their relative positions in the system.

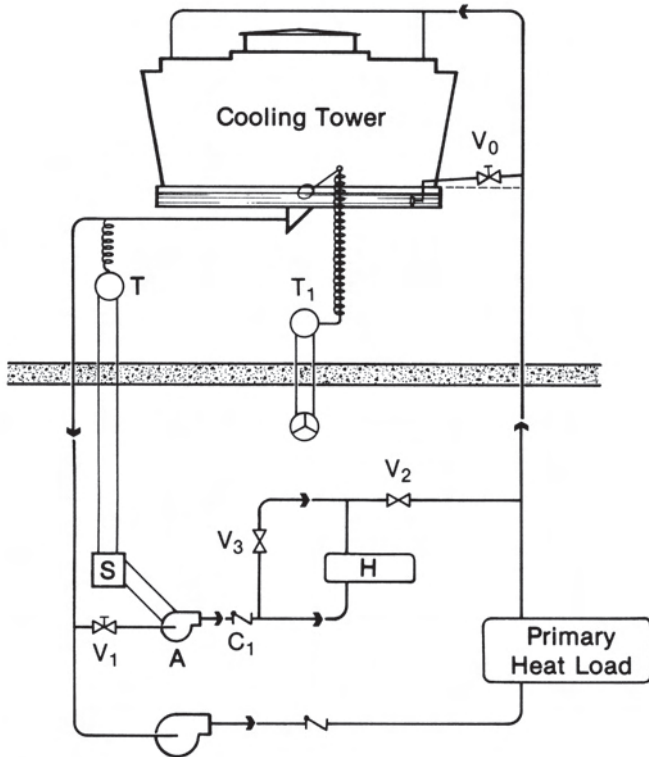

Figure 138 — By-pass circulation through heater for prevention of basin freezing.

Two by-pass lines are utilized to create a circulation loop independent of both the main pump and the cooling tower water distribution system. One by-passes the cooling tower riser, diverting flow directly into the cold water basin. The other line is installed in a warm area and connects the tower suction to the tower return, thus

by-passing the main pump-process system. This line includes a small auxiliary pump (A) complete with magnetic starter (S); a small instantaneous water heater (H) with a globe-valved ( $V_3$ ) by-pass; a gate valve ( $V_1$ ) preceding, and a check valve ( $C_1$ ) following the auxiliary pump.

The remaining components consist of an immersion thermostat (T), preferably located in the basin or suction line near the sump; a thermostat ( $T_1$ ) and heating cable system to protect the make-up line; and a globe valve ( $V_2$ ) at the discharge point of the interior by-pass.

When winter operation begins, gate valves  $V_0$  &  $V_1$ , and the globe valve  $V_2$  are fully opened by the tower operator. These valves remain open throughout the winter season, and should be closed only at the beginning of warm weather. The immersion thermostat is set to start the auxiliary pump, and energize the heater, at some temperature between 40°F and 45°F. Proper design provides for the water passing through the heater to pick up heat at a rate equivalent to that which is lost by the cold water basin and exposed piping.

The flow rate of the auxiliary pump should be sufficient to induce reasonable circulation in the cooling tower basin. Usually, this will be about 5% of the main pumping rate. The by-pass line from the riser to the cold water basin should be sized to allow that flow without causing an appreciable head of water to stand in the riser. Since the static lift and pipe losses are almost negligible in this system, primary head on the auxiliary pump will be contributed mainly by the losses in the instantaneous heater. The temperature rise (R) through the heater can be calculated by the following transposition of Formula (1):

$$R = \frac{\text{Heat Loss (Btu/hr)}}{\text{gpm} \times 500} = \text{°F} \quad (22)$$

Steam-to-water heaters predominate where low pressure steam is available, and where severe weather prevails during the winter. Electric heaters are most utilized on smaller installations, and where milder winters require less frequent system operation.

### E. FILTERING SYSTEMS

Section I, Article G of this text described the process by which airborne contaminants and total dissolved solids become concentrated in the cooling tower water circulating system. In like manner, undissolved solids (particulates or turbidity: See V-H-2) tend to become concentrated. At best, these particulates will tend to settle out in low velocity areas of the water system (such as the cooling tower basin) where they can become a breeding ground for bacteria, requiring frequent cleaning and flushing of the basin. At worst, they can degrade system heat transfer efficiency and, by their very presence, drastically increase the cost of chemicals for water treatment.

An increasing number of users are utilizing filtration systems, similar to that shown in Figure 139, to control particulate levels and thus maintain cleanliness of the tower and overall water circula-

tion system. Typically, these systems are sized to continuously filter the cooling tower basin water inventory at a rate equivalent to about 5% of the total circulation rate over the tower, depending upon the rate at which particulates are re-introduced into the system. In many cases, the filtration rate may need to be in excess of 10% of main flow.

Although filtration could be accomplished at almost any section of the water circulation system by means of a by-pass ("side stream") arrangement, location such that only the basin water inventory is filtered has proven very satisfactory. This is because the filtered return stream into the basin can be directed, through perforated piping or commercially available nozzles, to "sweep" collected sediment toward the filter's sump connection.

In processes where water passages are sufficiently small to be susceptible to clogging, filtration can be an invaluable asset.

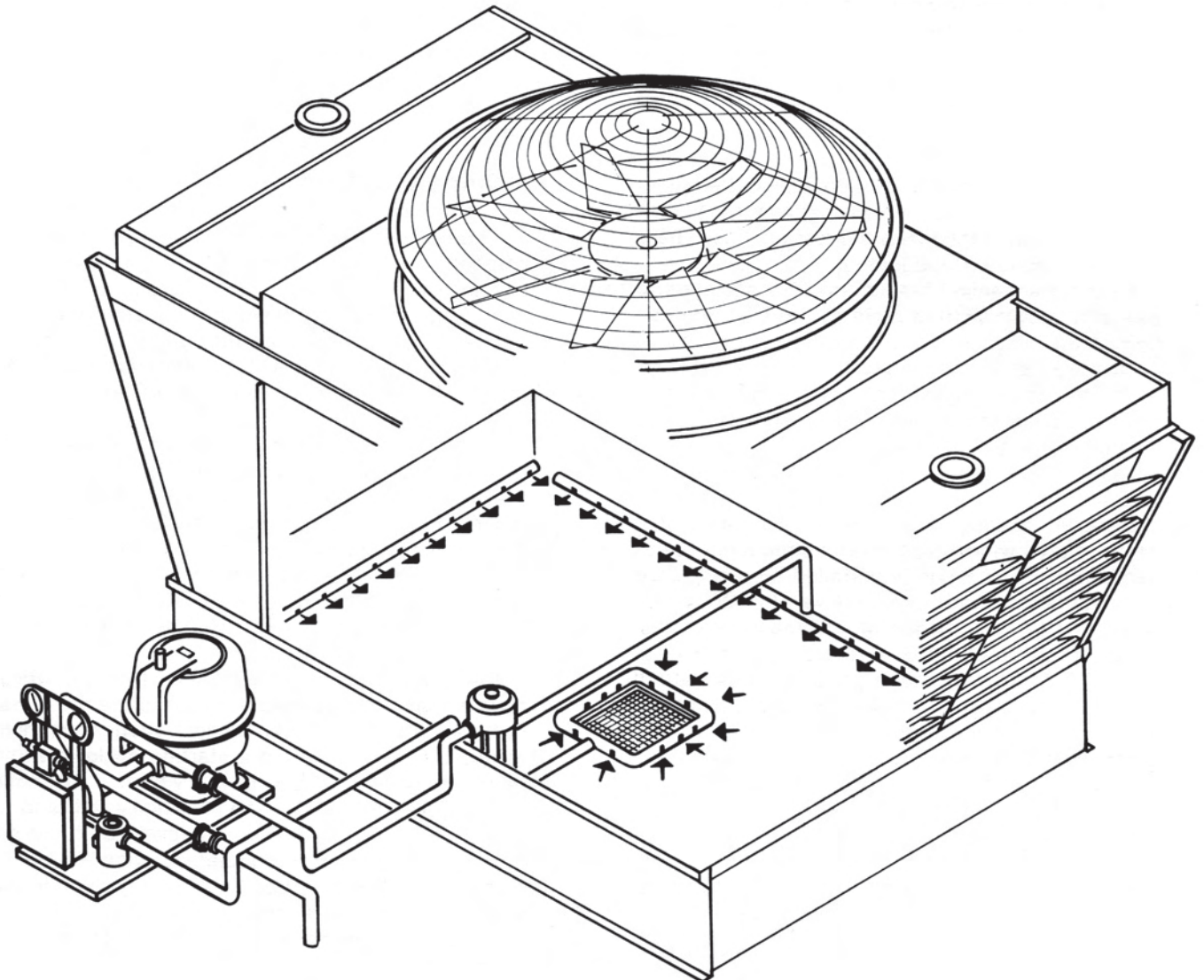

Figure 139 — Efficient use of "side stream" filtration keeps cooling tower basin clean.

## F. FAN BRAKES AND BACKSTOPS

When the fan motor of an induced draft cooling tower is de-energized, the fan may tend to "windmill" in either the forward or reverse direction, depending upon the velocity and direction of any natural air current through the fan cylinder. On towers where cells are separated by partitions, inoperative fans will usually tend to continue to rotate in the forward direction as long as the cells served by those fans are subjected to a water-side heat load. This is because of the natural upward movement of air induced by the warm water.

On towers where several fans operate over a common plenum, an inoperative fan will always rotate in the reverse direction because of the downdraft induced in its cylinder by the remaining operative fans. (The sequence of starting and stopping fans should always follow manufacturer's recommendations.)

There are several reasons why free windmilling of fans should be restricted, not the least of which is the desire to prolong mechanical equipment service life. When fans are re-started in a direction opposite to free rotation, all components of the mechanical equipment train are placed under abnormal mechanical and torsional stresses. Furthermore, motor windings are subjected to extended starting currents.

A number of devices are available to control windmilling. Sprag-type backstops can be mounted the front shaft extension of a double-shafted motor to prevent reverse rotation, leaving fans free to operate or windmill in the forward direction. These backstops are usually oil lubricated.

Electro-mechanical brakes are also designed for use with double-shafted motors. The electrical portion of the brake is wired into the motor leads in such a way as to mechanically energize the brake when the motor is electrically de-energized. A time delay is advisable to prevent the brake from energizing before the fan has lost its major momentum. This scheme effectively prevents windmilling in either direction.

Dynamic braking is a purely electrical system which retards windmilling in both directions. The dynamic braking package is installed as a portion of the motor's electrical controls. A very low DC voltage is applied to two phases of a three phase motor stator. If the motor starts to rotate, it is opposed by the DC field limiting motor speed to less than 10 rpm. Dynamic braking is relatively maintenance free and, since the components are located in a motor control center enclosure, corrosion does not present the potential problems inherent in a system located on the cooling tower.

Both electro-mechanical and dynamic braking allow full operation in either the forward or the reverse direction. This flexibility may be required for tower de-icing in extremely cold climates.

## G. AIR INLET SCREENS

In areas where leaves and debris can be blown or induced into the air inlet openings and, thereby, into the cold water basin to potentially foul the sump

screens, it is sometimes advisable to equip the tower with air inlet screens. Usually, the screening consists of ½" opening, galvanized wire mesh. On counterflow towers, as well as many crossflow towers, screening can be affixed to the air inlet structure in a relatively inexpensive fashion. The access demands of many towers, however, require that the screens be mounted in separate, removable panels. Although this arrangement is significantly more expensive, it is usually more attractive to the Owner/operator.

## H. DISTRIBUTION BASIN COVERS

Similarly, on crossflow towers located in heavily wooded areas, leaves and debris can find their way into hot water distribution basins. Although the open nature of these distribution basins enables them to be easily cleaned, the user may prefer to equip these basins with removable cover panels to reduce maintenance frequency, particularly in the fall of the year. In larger towers, this same effect is achieved by extending the elevated fan deck laterally to cover the hot water basins.

Distribution basin covers also protect the hot water from exposure to direct sunlight, thereby reducing the potential for algae formation. In many cases, this is the primary reason for their use.

## I. VIBRATION LIMIT SWITCH

A fan which continues to operate after having lost a blade is not only capable of doing tremendous damage to the mechanical equipment region of a cooling tower, but also jeopardizes the safety of nearby equipment and personnel. If a driveshaft continues to operate after partial failure of a flexible coupling, complete driveshaft failure is almost certainly assured, with the potential for even greater destruction.

A vibration limit switch is a vibration-sensitive device that protects the tower from damage that can result from mechanical equipment malfunction or failure. (Fig. 140) The switch functions when a predetermined vibration level is exceeded, causing power to be removed from the fan motor. Single and double-pole, double-throw switches are available to make an alarm circuit as well as remove motor power.

There are many types available, most of which have a mass that is displaced on excessive vibration, operating a switch. Some switches are held closed electrically during a starting cycle to avoid false shutdown. Electronic-type vibration switches are available to monitor the vibration level; and to sound an alarm at one vibration level – and turn off the fan motor at a higher vibration level.

Installation of the switch is normally outside the fan cylinder, near the motor. On larger towers, it is mounted on the motor end of the unitized support to sense vibration of the mechanical equipment as a whole. (Fig. 141) Since the switch is exposed to the elements, it must be weatherproof and corrosion resistant.

## J. FIRE PROTECTION, PREVENTION AND CONTROL

Although concrete and steel cooling tower structures will not burn, they can be rendered useless by significant exposure to a very hot fire. If their contents (fill, drift eliminators, etc.) are combustible, therefore, they can be placed in a high-risk category by fire insurance underwriters. However, with the advent of PVC fill and eliminators, insurers have begun to reassess the risk factors and, in many such cases, have permitted installation without a fire protection sprinkler system, and with no increase in premium.

Obviously, wood towers are more susceptible to fire, particularly after they have remained inoperative for a period of time sufficient to allow them to dry out. The use of PVC (or other materials formulated for fire-retardant characteristics) for fill and eliminators in wood-framed towers also has a risk-reducing effect, although not usually to the same extent as occurs in concrete or steel framed towers. Depending upon the criticality of the process being served by the tower, or the severity of local fire codes, insurance carriers may insist upon a simple wet-down system, at least, or may require a full fledged fire protection sprinkler system.

**Wet-Down Systems** are simple piping and nozzle arrangements designed to deliver a relatively small *continuous* flow of water to the top regions of the tower by means of a pump that takes suction from the tower's cold water basin. Flow in such a system needs to be no more than that required to maintain dampness in the primary wood components; and system sophistication is usually limited to an interlock that starts the wet-down system pump on main pump shutdown and a sensor that will prevent operation of the wet-down pump at air temperatures below about 35°F. It is important that the flow through such a system be continuous, because alternate wetting and drying of the wood can degrade its service life.

Periodic operation of the main pumps will serve to keep specific areas of the tower wet, but may leave certain critical areas unaffected. Circulating water over a crossflow tower, for example, will moisten the distribution basins, fill, major outboard structure and louver areas but, without air flow, will accomplish no appreciable moistening effect on the fan deck, drift eliminator, and plenum areas. Similarly, intermittent pump operation on a counterflow tower will moisten the fill and lower structure, but will leave the drift eliminators and entire upper areas relatively dry.

**Fire Protection Sprinkler Systems** for cooling towers are defined and governed by National Fire Protection Association (NFPA) Bulletin 214 (latest revision). The system normally consists of a rather intricate arrangement of piping, nozzles, valves, and sensors or fusible heads which cause the tower to be automatically deluged with water soon after the start of a fire. Piping within the tower is usually free of water, to prevent freezing. Water at a prescribed

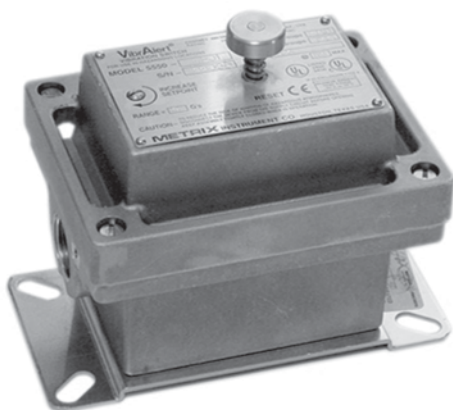

Figure 140 — Electronic vibration limit switch.

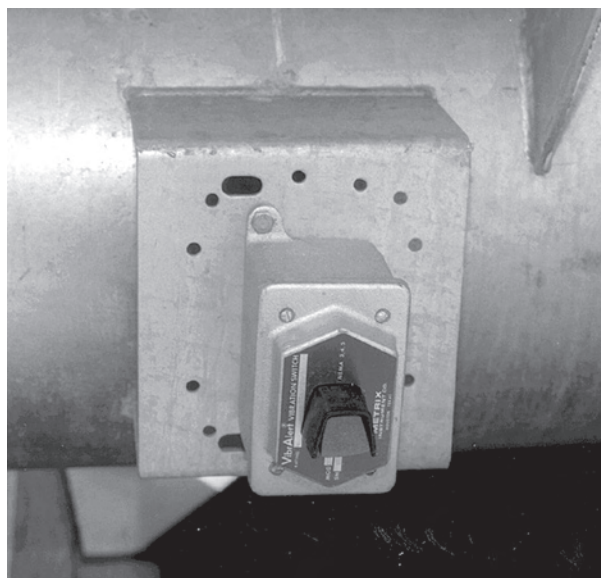

Figure 141 — Vibration limit switch mounted to react to mechanical equipment vibration.



## SECTION VI

residual pressure is available at an automatic valve, located within a nearby heated space. Operation of the valve is initiated either by thermostatic type sensors which react to an abnormal rate of temperature rise, or by fusible heads which cause pressure loss within a pneumatic control system.

In many cases, insurance underwriters for a plant will alter premium values in recognition of thoughtful modifications made to the cooling tower, whether or not it is equipped with a fire protection sprinkler system. Among those modifications are the following:

a. Where plastic items of significant scope are utilized in the tower, they may be formulated to retard or resist fire. Primary areas of concern would be casings, louvers, fan cylinders, fill and drift eliminators.

b. Selected top areas of the tower (notably fan decks) may be covered by a specified thickness of FRC (fiber-cement board), or similar fireproof material.

c. Partition walls between cells of a rectilinear tower may be designed to act as "fire walls" to prevent or delay the spread of fire. Typically, a ½" thickness of either treated Douglas Fir plywood or FRC (fiber-cement board on both sides of the transverse column line that constitutes a partition bent is recognized as a 20 minute barrier to the spread of fire. Fire walls of increased rating are accomplished by increasing the thickness of the material utilized.

Depending upon the scope of required modifications, their cost should be evaluated against the cost of a fire protection sprinkler system and/or the benefit of reduced insurance premiums.

## Thermal Performance Testing

### A. GENERAL

The actual performance level of an operating cooling tower can be accurately determined **only** by thermally testing the tower. The accuracy of testing is influenced by many variables, some controllable – some not. This fact normally precludes testing at the specific design conditions. However, the limits established by the appropriate ASME (American Society of Mechanical Engineers) or CTI (Cooling Technology Institute) Test Codes provide for testing within a relatively broad variability range.

The ASME Power Test Code for Atmospheric Water Cooling Equipment (PTC-23) and the CTI Acceptance Test Code for Water Cooling Towers (ATC-105) provide complete details for tower preparation, instrumentation, testing procedures, and computation of test results. These codes grant that procedures may be modified by mutual agreement whenever necessary to meet any specific contractual obligation, or to compensate for unusual conditions imposed by a particular installation. However, they stress the importance of conducting the test only during a period when tower operation and atmospheric conditions are stable.

Obtaining accurate data is the most difficult part of the test. Once the average test values have been established, the comparison with design capability is relatively easy. Both codes state that the measure of thermal capability of the cooling tower shall be the ratio of the test water circulating rate to the circulating water rate predicted by the manufactur-

er's performance curves. In addition, the CTI Code provides an alternative method for evaluating capability, whereby the "characteristic curve" is used in conjunction with basic theoretical data.

### B. TOWER PREPARATION FOR TEST

Prior to the test, the physical condition of the tower must be made to conform to the following:

1. The water distribution system must be free of foreign materials, and must be regulated to effect uniform water distribution in individual cells as well as between cells on multi-cell towers.
2. Fill and distribution systems must be level and free of foreign material.
3. Drift eliminators must be clean.
4. Positioning of instruments for obtaining temperature and water flow measurements must be so established as to reflect the true tower capability. (See appropriate Test Code.)
5. All test variables should be adjusted, if possible, to within the limitations imposed by the applicable Test Code.

### C. INSTRUMENTATION FOR TEST (Fig. 142)

Test data required for the performance evaluation of a mechanical draft cooling tower includes the water flow rate, the hot and cold water temperatures, the wet-bulb temperature, and the fan horsepower. The testing of a natural draft tower must also include the dry-bulb temperature but, of course, omits the need for fan power data. Make-up

Measure wind speed and direction upwind of tower in unobstructed area.

Measure gpm at appropriately located pitot tube taps.

Measure cold water temperature at pump discharge.

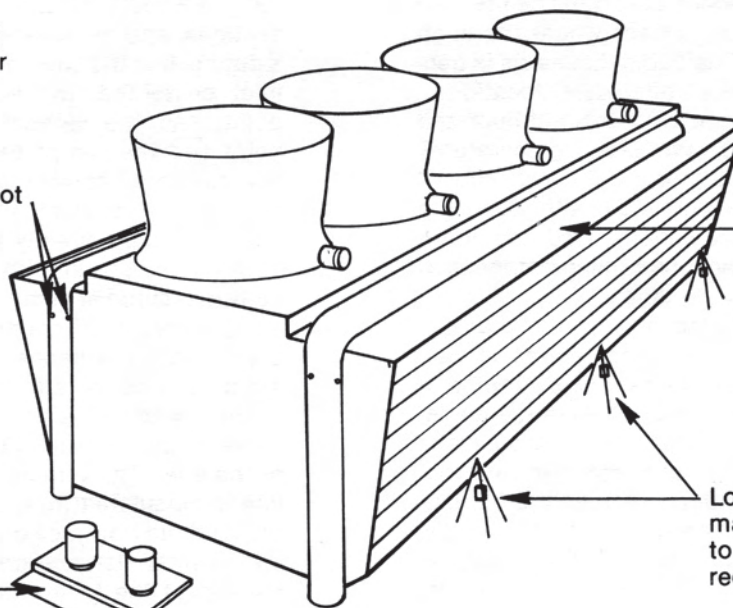

Measure bhp at motor starter with wattmeter. Factor for line loss.

Measure entering water temperature at flow control valve exit, or at thermometer well in inlet piping.

Locate psychrometers or matrix of RTD's appropriately to satisfy specific test code requirements.

Figure 142 — Typical sketch of test instrument locations.

and blowdown water quantities and temperatures, as well as any miscellaneous water sources, may need to be measured, depending upon their effect upon the aforementioned primary variables.

1. **Water flow rate** to the cooling tower can be determined by several means. Most commonly used is the pitot tube traverse method. It is both practical and accurate, provided laboratory calibration has been made. Other acceptable means include the orifice plate, venturi tube, and flow nozzle, all of which also require laboratory calibration. Tracer methods, as well as acoustic methods, have been developed (usually dilution techniques) and are being refined. Occasionally, pump curves are used to approximate the flow. Distribution basin nozzle curves (gpm vs depth of water over nozzle) are frequently used as a check method and, in the absence of other methods, may be used to measure flow directly.

The water flow rate is generally the initial test measurement made, so that any necessary adjustments may be made before the thermal data is obtained. The constancy of the water rate during the thermal test run may be checked by observing the pitot tube center-point reading, circulating pump discharge pressure, or other acceptable means.

2. **Water temperatures** should be obtained with calibrated mercury-in-glass thermometers or resistance-type sensors (RTDs, thermistors, etc.), either used in direct contact with the flowing water or inserted in thermometer wells. These instruments must reflect the true average temperature to and from the tower. The return (hot) water temperature to the tower is usually well mixed, and a single point of measurement will normally suffice. However, cold water temperatures from the tower can vary considerably throughout the collection basin. Therefore, care must be taken to select a point of measurement where thorough mixing has occurred. The pump discharge is generally considered to be a satisfactory location.

3. **Air temperatures** include both the wet-bulb and dry-bulb temperatures. Wet-bulb temperatures should be measured with mechanically-aspirated psychrometers whenever feasible, although sling psychrometers are occasionally used and do afford an alternate and accurate means of measuring this variable. (Figs. 19, 20 and 21)

All precautions required by the ASME or CTI Test Codes regarding the measurement of wet-bulb temperature should be exercised. Temperature-sensitive elements should, of course, be laboratory-calibrated if a high degree of accuracy is desired. Representative temperatures are obtained if the air flow induced across the thermometer bulb is approximately 1000 fpm, and distilled water is used to wet the wick. Generally, the average of three readings taken in rapid succession (10 seconds apart), after equilibrium is

reached, will indicate the true wet-bulb temperature at any one point.

The location of wet-bulb temperature measurement stations will depend on the contract guarantee. That is, whether the guarantee basis is **ambient** or **entering** wet-bulb temperature. (Sect. I-E-1) Reference should be made to the appropriate test code for exact locations of instruments. Any effect on wet-bulb thermometers from extraneous sources of heat must be taken into account when data evaluation is made.

Dry-bulb temperatures must also be measured with laboratory-calibrated instruments at locations called out by the appropriate test code. The measurement of dry-bulb temperature is confined primarily to natural draft towers.

4. **Brake horsepower** refers to the output of the fan prime mover, which is usually an electric motor. Thermal performance guarantees are based on a specific brake horsepower at the design thermal conditions, which establish a design air density. Fans should be adjusted prior to a scheduled test so that the horsepower is within 10% of the design value, after corrections to design air density have been made. Since input electric power is usually measured, the brake or output power must be computed by multiplying the input power by the motor efficiency. The efficiency and power factor are obtained from the motor manufacturer.

The preferred instrument for power determination is a wattmeter. Power may also be obtained with a volt-ammeter, but power factor as well as efficiency must be applied as multipliers to determine the brake horsepower. Line losses from the point of measurement to the fan motor must be considered when the power is remotely measured.

5. **Tower pumping head** is the total dynamic head of water at the centerline of the circulating water inlet to the cooling tower, with equalized flow to all sections, and referred to the tower basin curb as a datum. It is the sum of the static pressure at the inlet centerline, the velocity pressure at that point, and the vertical distance between that point and the top of the basin curb. The tower pumping head does not normally include the friction loss in the riser. The static pressure is seldom measured directly at the inlet centerline because of the unsuitability of this location. It is usually measured at some point in the tower riser by using either a differential manometer or a calibrated pressure gauge. Pitot tube tap locations are usually suitable for this measurement.

The measured static pressure must be converted to the equivalent pressure at the centerline of inlet. The velocity pressure at inlet centerline is calculated from the measured water flow rate and the flow area of the conduit at that point. The vertical distance from the inlet centerline to the top of the basin curb is obtained by direct measurement.

**D. OPERATING CONDITIONS DURING TEST**

Current ASME and CTI Test Codes suggest the following limitations to variations from design to be observed during testing:

- Water Rate..... ±10% of design
- Cooling Range..... ±20% of design
- Heat Load..... ±20% of design
- Wet-Bulb Temperature\*..... ±10°F of design
- Wet-Bulb Temperature \*\* .... +5°F, - 15°F of design
- Dry-Bulb Temperature\*..... ±20°F of design
- Wind Velocity..... generally less than 10 mph
- Fan Power..... ±10% of design

\*CTI Test Code

\*\*ASME Test Code

There will be times when operating or atmospheric conditions will not permit a test to be performed within the above limits. However, testing can proceed by mutual agreement among responsible testing parties, provided test conditions are covered by the manufacturer's performance curves.

**E. CONDUCTING THE TEST**

The accuracy of the test depends upon stable operating and atmospheric conditions. Those conditions which are subject to control should be closely regulated. For conditions that cannot be controlled (such as wet-bulb temperatures and wind velocity), tests should be confined to time periods when minimum variances occur. The duration of any test period should not be less than one hour after steady-state conditions have been established.

A test schedule should be established with a CTI Licensed Test Agency, or other mutually agreed independent third party testing agency. Most testing is now conducted using electronic data acquisition systems.

**F. EVALUATION OF TEST DATA**

Arithmetical averages are developed for all temperatures, and water flow rates as well as fan power are calculated at the conclusion of data collection. The test analysis of data should follow the ASME or CTI Test Code methods for evaluation of tower capability. If the manufacturer's performance curves are not available to the Owner, the following method will afford a reasonably accurate means of evaluating the thermal performance of a tower:

For every gpm of water cooled by a tower, the cooling range and the approach temperature (Fig. 26), relative to a given wet-bulb temperature, establishes the degree of thermal capability or "Rating Factor". Rating Factors for various combinations of range and approach (at indicated wet-bulb temperatures) are shown in figures 143 thru 147. "Capacity Units" are then established as the product of the Rating Factor and the water rate in accordance with the following formula:

$$\text{Capacity Units} = \text{gpm} \times \text{Rating Factor} \quad (23)$$

The capacity Units **required** to meet the design thermal conditions are calculated from Formula (23). The **available** Capacity Units are also determined from Formula (23). In general, the tower capability is the ratio of the Capacity Units available to the Capacity Units required, as follows:

$$\text{Tower Capability} = \frac{\text{Capacity Units avail.}}{\text{Capacity Units req.}} \times 100 \quad (24)$$

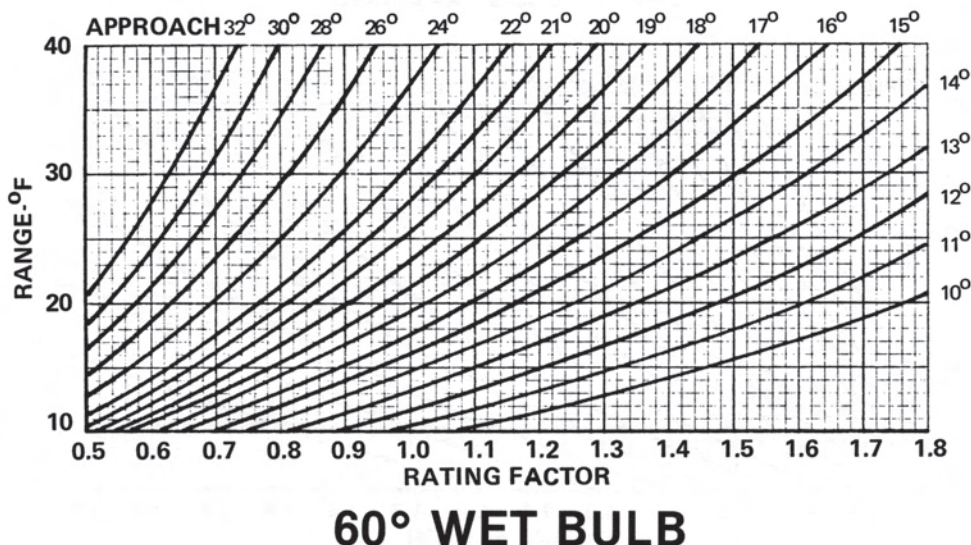

Figure 143

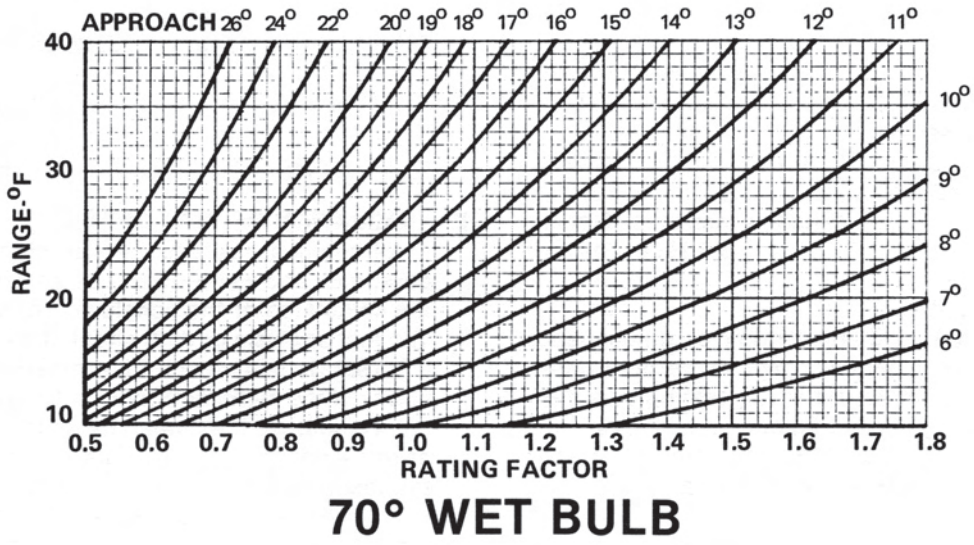

Figure 144

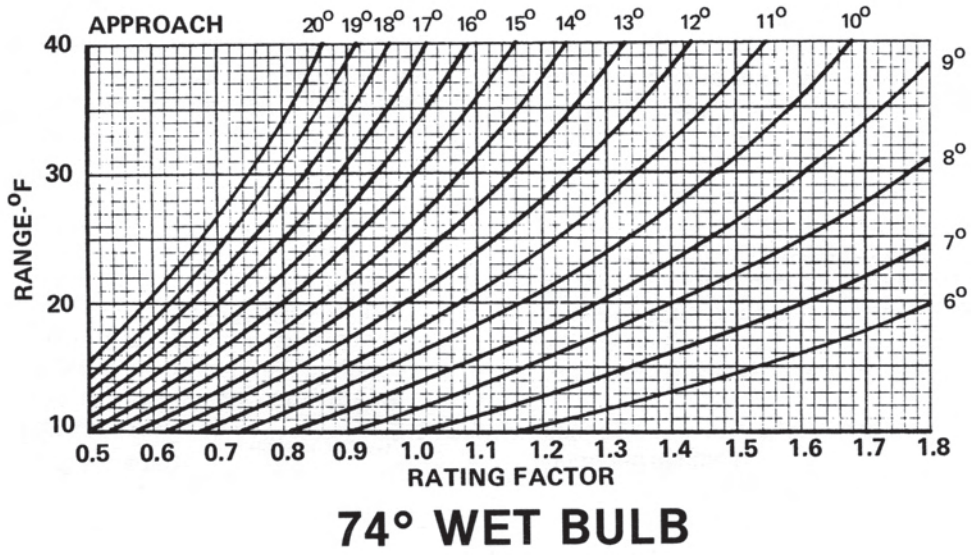

Figure 145

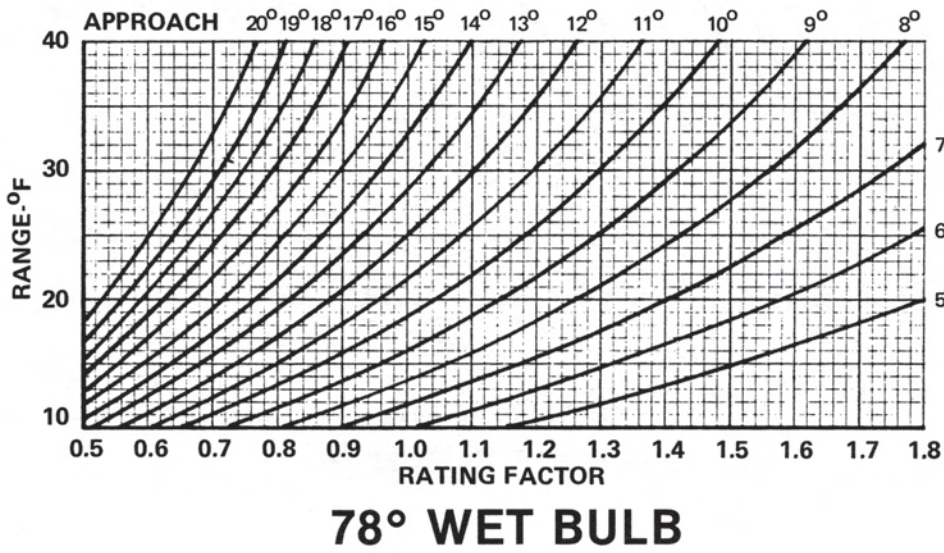

Figure 146

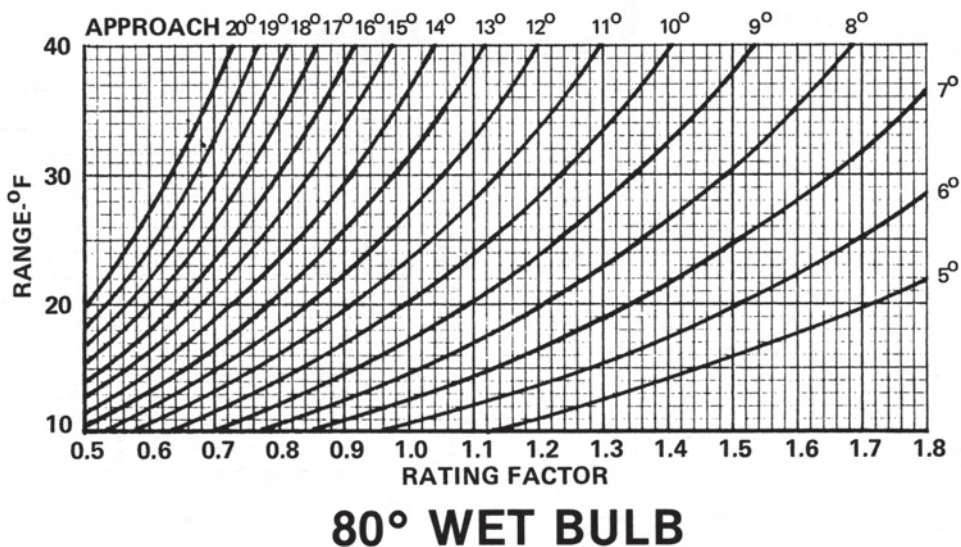

Figure 147

However, because tests are seldom conducted with the fans operating exactly at the design fan brake horsepower, an adjustment must be made to account for the variation in test thermal performance caused by this variation in air flow (or fan power). Since air rate varies directly as water rate and also as the cube root of fan power (at constant hot water, cold water, and wet-bulb temperatures) the adjustment is applied directly to the test water rate as follows:

$$\text{Adj. test gpm} = \text{test gpm} \times \sqrt[3]{\frac{\text{design fan bhp}}{\text{test fan bhp}}} \quad (25)$$

The *available* "Capacity Units" must then be calculated as the product of the adjusted test water rate (gpm) and the test Rating Factor. Tower capacity (Formula (24)) must then incorporate a fan power correction whenever required. The following example typifies the evaluation of test data:

	<i>Design</i>	<i>Test</i>
Water Rate (gpm):	10,000	10,830
Hot Water Temperature (°F):	105.0	99.2
Cold Water Temperature (°F):	85.0	81.1
Wet-Bulb Temperature (°F):	78.0	72.2
Range (°F):	20.0	18.1
Approach (°F):	7.0	8.9
Fan Horsepower (bhp):	75.0	71.2

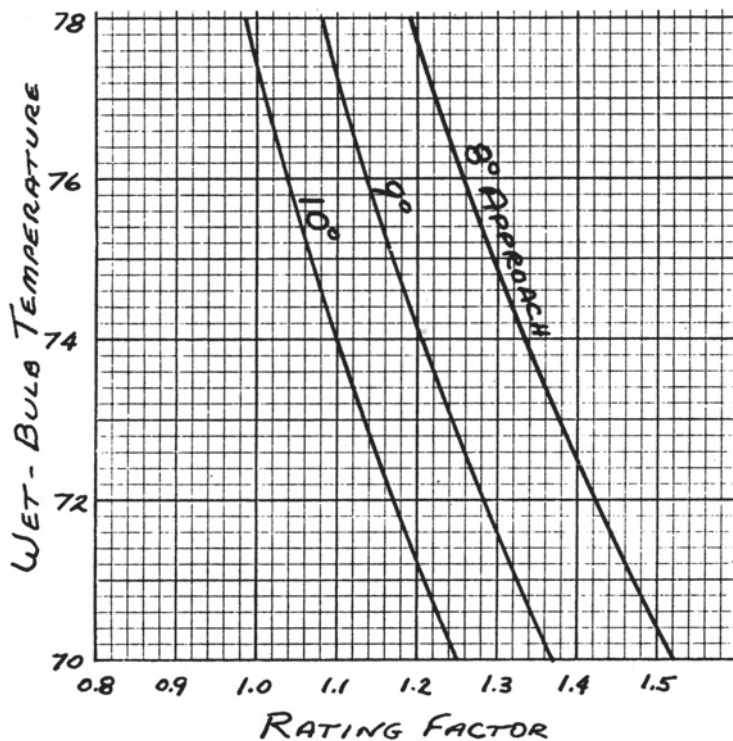

Figure 148 — Curve plotted to bracket specific test region.

**Required Capacity:** The Rating Factor corresponding to 20°F range and 7°F approach, from the 78°F wet-bulb curve shown in Figure 146, is 1.41. Substituting in Formula (23),

$$1.41 \times 10,000 \text{ gpm} = 14,100 \text{ Capacity Units required}$$

**Available Capacity:** Testing was conducted at 71.2 fan bhp, so the calculated test gpm at 75 fan bhp (design) must be calculated, using Formula (25).

$$\text{Adj. test gpm} = 10,830 \times \sqrt[3]{\frac{75}{71.2}} = 11,019 \text{ gpm}$$

Because the test was conducted at 72.2°F wet-bulb and 8.9°F approach, a double interpolation is required to obtain the corresponding test Rating Factor.

Rating Factors for 18.1 °F Range		
@8°A	@9°A	@10°A
1.520	1.370	1.250
1.335	1.205	1.100
1.190	1.080	0.985

Fig. 144-70° wet-bulb

Fig. 145-74° wet-bulb

Fig. 146-78° wet-bulb

The Rating Factors for each approach are plotted against wet-bulb temperature as shown in Figure 148. The Rating Factors for 72.2°F wet-bulb and 8°, 9° & 10°F approach are read from this curve as 1.414, 1.276 & 1.162 respectively. These factors are then plotted in Figure 149, and 1.29 is seen to be the Rating Factor unique to an 8.9°F approach, an 18.1°F range, and a 72.2°F wet-bulb temperature.

Substituting calculated values in Formula (23):

$$\text{Capacity Units available} = 1.29 \times 11,019$$

$$(\text{adjusted test gpm}) = 14,215$$

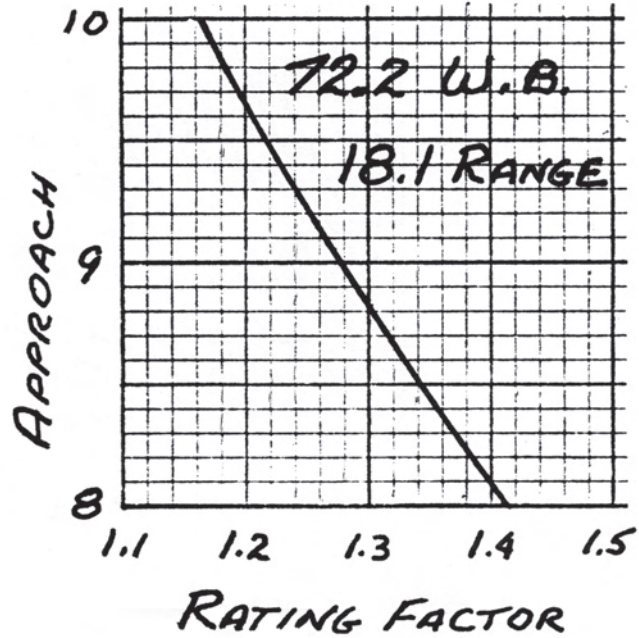

Figure 149 — Curve plotted to identify specific test point.

Substituting the **available** and **required** Capacity Units in Formula (24):

$$\text{Tower Capability} = \frac{14,215 \times 100}{14,100} = 100.8\%$$

The test indicates that the tower will cool 100.8% of the design water rate, or that it has 100.8% of the required capacity. This is well within recognized test tolerances of ±2%, under stable test conditions.

## Owner Responsibilities

### A. GENERAL

Cooling tower manufacturers design for successful performance when the tower is operating under a given set of conditions. If the information establishing those conditions is accurate, then the cooling tower should perform properly and it is the responsibility of the manufacturer to assure that it does so. Given fallacious or poorly defined conditions against which to design, however, the probability of arriving at a properly sized cooling tower of the appropriate type is remote.

At various places throughout this text, certain determinations fundamental to the proper selection of a cooling tower, as well as its operational success, are indicated to be the responsibility of the Owner or specifying engineer, as the case may be. Those points are herewith reiterated for emphasis, along with numerous other inputs and actions which are pertinent to a cooling tower's design, installation and operation, and which are the Owner's responsibility to ascertain and perform.

### B. COVERING SPECIFICATIONS

In order to promote receipt of the most competitive bid offerings, the description of the cooling tower required, and its intended service, must be sufficiently inclusive to assure a fair comparison of all bids received. However, specifications should not be so rigid as to rule out new techniques or approaches, but should cover base requirements dictated by the project, with possible alternatives suggested by bidders reviewed for acceptance or rejection.

Beyond those basic considerations, the wise Owner will avoid becoming overly specific. Restrictive specifications usually favor but one bidder, and are discouraging to most others. They also produce very little incentive for the preferred bidder to make his best offering. It is much better to be "specific" with respect to the problem, and "general" with respect to the tower. This allows manufacturers to offer their best solutions, and usually works to the benefit of the Owner.

The following minimum information must be related, with appropriate additions inserted where project peculiarities dictate, or strong preferences exist:

1. **Type of Tower Preferred:** Prior to writing the specifications, a prudent Owner will have discussed the project requirements with one or more reputable manufacturers, and will have determined at least the basic type and configuration of cooling tower best suited to the specific need. For example, he may have found that consideration of natural draft, or any of the "specialized" towers (Sect. V), is unwarranted. He may also have determined that the available space (particularly in the light of future planning) best lends itself to a particular shape (i.e. round or rectilinear).

If there are overriding reasons for having

chosen a particular type, configuration, or basic construction material, an explanatory paragraph early in the specifications shows courtesy to the prospective bidders, and usually forestalls unnecessary discussion.

2. **Type of Service:** Specific information not only as to the basic industry, but also with respect to the particular process within that industry will tend to work to the Owner's advantage. Some manufacturers, having provided cooling towers for similar situations, may offer features or accessories known to be beneficial to the operation or efficiency of the process.
3. **Tower Heat Load:** (Sect. I-E-3) Since it governs the size of the cooling tower, the total heat load to be rejected to the circulating water system must be accurately determined and stated.
4. **Heat Load Configuration:** (Sect. I-E-4) Indicate the circulating water rate (gpm), incoming hot water temperature, and desired cold water temperature at design conditions.
5. **Design Wet-Bulb Temperature:** (Section I-E-1) Be clear as to whether this is to be treated as "entering" or "ambient" in the design of the tower.
6. **Dry-Bulb and/or Relative Humidity:** (Sect. I-E-2) Although knowledge of these values is critical only on certain types of towers, it is good practice to establish them on every project as a basis for possible future evaporation rate determination or plume behavior studies.
7. **Water Quality:** (Sect. I-G) A tabulated analysis of the qualities of both the make-up water and the circulating water (at the intended number of concentrations) must be included. Values for the circulating water should also include any anticipated effect of atmospheric pollution.
8. **Materials of Construction:** (Sect. I-F et al) Owners who have had considerable experience in the purchase and operation of cooling towers usually tend to write specifications which are quite explicit in their identification of the material to be used in each of the tower's components. In many cases, however, such specifications are a reflection of the materials utilized in the last tower purchased and, if taken literally, may preclude utilization of better material concepts developed in the interim.

Generally speaking, the basic material description of a cooling tower (i.e. "a wood tower"; "a pultruded fiberglass tower"; "a steel tower"; "a concrete tower"; etc.) refers to the material with which the tower is structurally framed, and establishes the primary intent as to the type of materials required in the tower's remaining components. This is not to say that mere specification of framework material will assure an Owner's total satisfaction with the various materials offered by bidders for the tower's remaining



components, but it will set a standard by which a bidder can interpret his alternatives.

Ideally, an explicit component material specification will be written, modified by the indicated understanding that an equal or better material will be considered for acceptance. Although such indications occasionally tend to complicate the Owner's decision making process, a correct decision as to what constitutes "current best technology" will produce overriding benefits. Furthermore, the Owner will normally be able to draw upon experience reported in various other industries.

A description of the primary structural and mechanical components is covered in Sections II and III. The purchaser's intention regarding their construction and design should be covered in the specifications, augmented by requirements for appropriate auxiliary devices from Section VI, or elsewhere.

9. **Structural Loading:** To the greatest degree possible, standard design criteria promulgated by recognized sources (such as those mentioned in Section II, Article C) should be specified. Wind and earthquake loads specified should be commensurate with geographical data, unless site-related peculiarities dictate otherwise. (It is wise to relate the reason for any specific deviation, in order to avoid confusion.)

The responsibility for provision of the cold water basin (Sect. II-B) should be made clear and, where applicable, its material specified.

The foundation itself, as well as the capability of the soil and foundation to withstand the dead and dynamic loads generated as a result of the cooling tower (with little or no differential settlement) is the responsibility of the Owner.

### C. TOWER ORIENTATION AND SITE SERVICES

A site plan drawing should be included with the specifications showing the intended location of the cooling tower, as well as any anticipated future towers. This drawing should indicate the elevations of all primary site structures. It should also include a rose of average annual winds, **emphasizing the wind force and direction coincident with the design wet-bulb temperature.**

On projects where the installation of the cooling tower will involve a significant amount of site construction effort, the drawings should include topographical features in sufficient detail to enable the bidder to pre-plan the storage of material and the movement of equipment.

Provision for construction power and water adjacent to the tower location should be made and their terminal points identified on the drawings. Specifications should clearly define site entry requirements, freedom of access both to work areas and comfort facilities, and work rules. Project agreements affecting labor relations must be explicitly stated.

### D. ECONOMIC EVALUATION PARAMETERS

Readers to this point in the text will have gathered that a multitude of different cooling tower types, designs, and configurations stand ready to dissipate a given heat load. As various physical and environmental qualifications are added to the base requirement, however, large groups of possibilities begin to fall out of consideration until, after some ultimate refinement, only a manageable dozen or so candidates remain.

The winner is usually chosen by a process of economic evaluation, wherein the cost impact of all operational and peripheral factors are added to the base cost of the cooling tower to obtain a "total evaluated cost." Among the factors which may be considered are the following:

1. **Pump Head Evaluation:** (Sect. V-E) The head loss attributable to the cooling tower causes pump energy to be expended for the period of time under evaluation (plant life, amortization period, etc.), the cost of which is usually brought to present worth and expressed as dollars per foot of head.
2. **Fan Power Evaluation:** (Sect. V-F) On mechanical draft cooling towers, a similar evaluation of the extrapolated cost of fan operation should be considered. Unlike pump power evaluation, however, fan usage should be factored to reflect the reduction in total fan operation that will be produced by annual variations in wet-bulb temperature. Fan power evaluation may be expressed as dollars per horsepower or dollars per kW.
3. **Basin Evaluation:** Real estate is utilized by a cooling tower and becomes unavailable for other use. Costs are also incurred in excavation and in the provision of unique foundations, such as pilings or caissons. Except in those cases where the basin is included within the cooling tower manufacturer's scope of work, the cost of basin installation is usually evaluated. Applicable costs are expressed as dollars per sq. ft. of basin area.
4. **Electrical and Wiring Evaluation:** (Sect. IV) Cooling tower motors are individually wired and controlled. Therefore, a portion of the Owner's overall electrical installation cost will vary directly with the number of fans with which the tower is equipped. This evaluated cost is expressed as dollars per fan.
5. **Piping Evaluation:** Variations in cooling tower configuration and placement (Fig. 39) can result in significantly different amounts of piping required. Piping required beyond a specified point should be evaluated in terms of dollars per foot.
6. **Capital Cost Evaluation:** The long-term cost of financing the purchase of equipment should be evaluated and expressed as a factor to be applied to the base cost.

*A detailed description of the Owner's intentions with respect to evaluation will enable the bidder to apply those parameters to various selections, resulting in an offering of best advantage to the purchaser.*

## E. CONTRACTUAL INFORMATION

The following points, among others, will form the basis for an ultimate contract, and maximum attention to clarity will result in the greatest understanding between parties:

1. **Scope of Work:** Of vital importance to the bidder is a thorough understanding of where his scope of endeavor begins and ends. Planned terminal points of supply and return piping, for example, should be well defined.

Assignment of work functions that fall outside the bidder's normal expertise would be avoided. This would include soil analysis and foundation requirements, piping external to the tower, and electrical work. Also, except in the case of concrete towers, the design and installation of a concrete collection basin is considered the user's responsibility.

2. **Contract and Construction Timing:** Accurate knowledge of planned milestone dates is of prime importance to the bidder in the preparation of his proposal. Those of main concern are: 1) date proposal is to be submitted; 2) date contract will be signed; 3) date site will be ready for start of construction; 4) date construction is required to be complete; and 5) date of final payment.

The time interval between receipt of inquiry and proposal submission should be sufficient to allow the bidder's investigation of several alternatives, out of which will come his best offering. Adequate time for the preparation of a comprehensive proposal may vary from as little as two weeks for the pre-designed towers utilized on smaller applications to as much as ten weeks for the custom-designed larger towers of greater specialization.

The length of time that a bidder is able to maintain validity of his proposal pricing is usually a reflection of the cost stability of those commodities from which the major cooling tower components are manufactured. Therefore, he seeks a contract date that is within the time limitation imposed by his suppliers. Periods of validity usually vary from 30 days on smaller projects to as much as 90 days on projects of larger size. In situations of unpredictable contract dates, or significantly volatile cost excursions, bidders may have no choice but to reserve the right to adjust base pricing at the time of contract.

Although procurement and preparation of design drawings usually begins soon after contract signing, the dates of site readiness and required completion establish the interval of time allowed the bidder for on-site construction activities. In the case of a factory-assembled tower, of course, only a required shipping date would be needed. Larger towers, involving appreciable manufacturing and construction effort, may require a minimum interval from date of contract to date of completion of about one year for towers of wood construction, and approximately two years for concrete towers.

Knowledge of the anticipated date that final payment will be received is vital to the manufacturer's planned cash flow. Delays in the receipt of final payment factor into an extended borrowing period, the cost of which must be covered by contract pricing. The Owner's best combination of protection and cost usually occurs when the negotiation of a final payment date takes the reputation of the manufacturer into consideration.

3. **Insurance Requirements:** The type and limits of insurance that will be required by the contract should be clearly defined in the inquiry. If the Owner intends to carry "wrap-up" insurance on the entire project, full disclosure of its nature will enable the manufacturer to evaluate cost reductions to be reflected in the proposal pricing.
4. **Performance Test Requirements:** If a thermal performance test is desired, the specifications should identify the code (ASME or CTI) under which the test will be conducted; should indicate whether or not the cost of the test is to be included in the cooling tower proposal; and should establish a limiting date for the test. Usually, tests are conducted during the first summer of tower operation. All thermometer wells and pitot-tube taps necessary to facilitate test readings must be procured and installed by the Owner.

Although thermal testing establishes the actual performance level of a cooling tower, relative to design requirements, the value of such a test must ultimately be weighed against its cost. On relatively small projects, the cost of a thermal performance test can amount to a substantial portion of the total cooling tower contract. A knowledgeable Owner may choose to include a specified performance test as a contract option to be exercised only if his own in-house test (Sect. VII) reveals an apparent performance deficiency.

5. **Terms of Payment:** Even in "lump sum" cooling tower construction contracts, portions applicable to materials and labor are customarily identified to facilitate separate modes of invoicing. Materials, for example, are normally invoiced progressively as materials are shipped to the site (PAMS), whereas field labor is invoiced monthly as work progresses (MAWP). Occasionally, the engineering portion of large jobs (usually incorporated as a component of the Materials contract) will be identified for invoicing and payment during an appropriate early phase of the contract.

Inquiry documents should define the Owner's plan for payment of invoices. The amount of "retention" should also be clearly stated, as well as the aforementioned date of final payment. Unreasonable requirements, of course, represent costs which usually reflect themselves in the total contract price.

6. **Provision for Escalation:** Except on short-term, quick shipment type contracts, typical of those involving factory-assembled towers, historical fluctuations in component costs have made "firm price"

contracts of little advantage to either the Owner or the manufacturer. Parity normally requires that the quoted price of a cooling tower be based upon known costs at the time of proposal, subject to escalation (upward or downward) corresponding to the relative level of acceptable escalator indices at the time of a material or labor event.

Materials contracts, for example, are usually apportioned into values assignable to various Bureau of Labor Statistics (BLS) commodity indices, with the ultimate value of a shipment established by the level of the appropriate BLS index at time of shipment, compared to its level at time of proposal.

Labor contracts are apportioned to various craft functions, with progressive invoicing reflecting the change in craft costs at the time of actual usage.

## F. COMPARING CAPABILITY OF PROPOSED TOWERS

On the strength of the thermal performance of all offerings being "guaranteed", many Owners will purchase the tower whose total evaluated cost (Art. D of this Section) is lowest, without reservation. Those who do so are often disappointed to discover that the tower purchased does not perform as it should, and are stunned to find out the additional costs involved in improving its performance.

Standard industry thermal performance guarantees provide for the following typical steps toward the remedy of a performance deficiency: 1) the manufacturer will make alterations to the tower in an effort to improve performance; and 2) the manufacturer will either install additional cooling tower capacity, or will refund a percentage of the contract price proportional to the performance deficiency.

In either case, the additional materials and/or labor required of the manufacturer to effect performance improvement is limited to the scope of the original contract. Therefore, the cost of any additional foundation, basin, piping, electrical wiring, or control mechanisms required would be to the purchaser's account.

Although these potential costs are obvious, and significant, they seldom represent the total impact upon the Owner who has purchased a deficient tower. In many cases, any alteration made to the tower may require an increase in fan power, the additional cost of which accrues throughout the operating life of the cooling tower.

Occasionally, errors in calculation on the part of a bidder may result in a quoted fan horsepower that is sufficiently low to cause the ultimate purchase of his offering. After installation and testing, a simple repitching of the fan blades may solve the problem of performance deficiency—but the additional longterm cost of fan power becomes the Owner's problem.

It is incumbent upon the owner, therefore, to ascertain both the capability and reputation of the apparent winning bidder prior to the placement of an order.

## G. CLEANING AND BIOLOGICAL CONTROL

Cooling towers must be cleaned on a regular basis to minimize the growth of bacteria, including *Legionella Pneumophila* (which causes Legionnaires' Disease) and avoid the risk of sickness or death. Cooling tower operators should always follow maintenance procedures which reduce, to a minimum, the opportunity for bacterial contamination.

Regular cleaning procedures are a particular concern for cooling towers in commercial HVAC service. Because they are often close to the public, the risk of infection from poorly maintained cooling towers is elevated. Visual inspection of these towers should take place weekly when the towers are operating. Flushing and cleaning should be performed before and after each cooling season, twice per year is the preferred frequency.

***A reliable water treatment program, including biocidal control means, should be installed and maintained.*** Filtration devices may be employed to reduce the suspended solids concentration, thus increasing the effectiveness of the water treatment program.

Operators should use the following disinfection procedure when starting a cooling tower that has been out of service for an extended period of time.

Drain down the water system if possible. Clean all debris, such as leaves and dirt from the tower. Fill the system with water. While operating the cooling water pump(s) and prior to operating the cooling tower fan, execute one of the two alternate biocidal treatment programs described below:

- Resume treatment with the biocide which had been used prior to shutdown. Utilize the services of the water treatment supplier. Maintain the maximum recommended biocide residual (for the specific biocide) for a sufficient period of time (residual and time will vary with the biocide) to bring the system under good biological control. -or-

- Treat the system with sodium hypochlorite to a level of 4 to 5 mg/L (ppm) **free** chlorine residual at a pH of 7.0 to 7.6. The chlorine residual must be held at 4 to 5 mg/L (ppm) for six hours, measurable with standard commercial water test kits.

Once one of these two biocidal treatments has been successfully completed, the fan can be turned on and the system returned to service. Resume the standard water treatment program (including biocidal treatment).

If the cooling tower is not drained prior to startup, the operator should perform one of the two previous biocidal treatments directly to the cooling water storage vessel (cooling tower sump, drain down tank, etc.) without circulating stagnant water over the cooling tower fill or operating the cooling tower fan.

After biocidal pretreatment is completed, cooling water may be circulated over the tower fill with the fan off. After biocidal treatment has been maintained for at least six hours, the fan may be operated and the system returned to service.

## Tables

**Table 1 – Heat absorbed by Cooling Water for Various Types of Equipment**

<b>EQUIPMENT</b>	<b>BTU</b>	<b>GPM</b>	<b>*COOLING RANGE °F</b>
<b>Air Conditioning or Refrigeration</b>			
	<b>Per Ton</b>	<b>Per Ton</b>	
Electric motor driven compressor	250/min	1.5-3	10-20
Engine driven compressor	300+/min	3-3.6	10-12
Steam turbine driven compressor	500+/min	2-3	20-30
Absorption machine	500+/min	3-4	15-20
Steam jet refrigeration, 100 psi steam pressure, 2" Hg vacuum	800+/min	4-6	16-24
<b>Steam Condensing (Power Plant)</b>			
	<b>Per lb steam</b>	<b>Per kW</b>	
Fossil fuel, surface condenser	1000+	.3-.7	14-30
B.W. nuclear fuel surface condenser	1000+	.5-.7	20-30
<b>Diesel Engine Jacket Water and Lube Oil</b>			
	<b>Per bhp</b>	<b>Per bhp</b>	
Four-cycle, supercharged	2600/hr	.26	20
Four-cycle, non-supercharged	3000/hr	.30	20
Two-cycle, scavenging large unit	2500/hr	.25	20
Two-cycle, scavenging high speed	2200/hr	.22	20
<b>Natural Gas Engine Jacket Water and Lube Oil</b>			
	<b>Per bhp</b>	<b>Per bhp</b>	
Four-cycle engine	4500/hr	.45	20
Two-cycle engine	4000/hr	.40	20
<b>Electric-Motor Driven Air Compressors</b>			
	<b>Per bhp</b>	<b>Per bhp</b>	
Single-stage	380/hr	.076	10
Single-stage, with aftercooler	2545/hr	.51	10
Two-stage, with intercooler	1530/hr	.31	10
Two-stage, with intercooler and aftercooler	2545/hr	.51	10
Note: For engine or steam turbine drive, add jacket water or steam condensing load.			
<b>Plastic Injection Molding Machines</b>			
	<b>Per ounce capacity</b>		
	125/min	1.5	10
<b>Hydraulic Oil Cooling</b>	2545/hr/bhp	.51/bhp	10
<b>Welding Tip Cooling</b>	84/min (avg)	1.0	10
<b>Electric Furnace Cooling</b>	200/hr/kW	.02/kW	20
<b>Quench Oil Cooling</b>	Load = Specific heat x lbs x temperature cooled		

\*When possible, secure actual heat load and water quantity to be circulated, and apply in Formula (1) on page 22

SECTION IX

**Table 2 – Data for Rapid Calculation of Saturation and Stability Indexes (based on Langelier formulas, Larson-Buswell residue, temperature adjustments and arranged by Eskel Nordell).**

<b>A</b>		<b>B</b>	
Total Solids ppm	<b>A</b>	Temperature °F	<b>B</b>
50-300	0.1	32-34	2.6
400-1000	0.2	36-42	2.5
		44-48	2.4
		50-56	2.3
		58-62	2.2
		64-70	2.1
		72-80	2.0
		82-88	1.9
		90-98	1.8
		100-110	1.7
		112-122	1.6
		124-132	1.5
		134-146	1.4
		148-160	1.3
		162-178	1.2

<b>C</b>		<b>D</b>	
Calcium Hardness ppm or CaCO <sub>3</sub>	<b>C</b>	M.O. Alkalinity ppm or CaCO <sub>3</sub>	<b>D</b>
10-11	0.6	10-11	1.0
12-13	0.7	12-13	1.1
14-17	0.8	14-17	1.2
18-22	0.9	18-22	1.3
23-27	1.0	23-27	1.4
29-34	1.1	28-34	1.5
35-43	1.2	35-43	1.6
44-55	1.3	44-55	1.7
56-69	1.4	56-69	1.8
70-87	1.5	70-87	1.9
88-110	1.6	88-110	2.0
111-138	1.7	111-138	2.1
139-174	1.8	139-174	2.2
175-220	1.9	175-220	2.3
230-270	2.0	230-270	2.4
280-340	2.1	280-340	2.5
350-430	2.2	350-430	2.6
440-550	2.3	440-550	2.7
560-690	2.4	560-690	2.8
700-870	2.5	700-870	2.9
880-1000	2.6	880-1000	3.0

Saturation Index = pH (actual) – (9.3 + A + B) + (C + D)  
 Stability Index = 2[(9.3 + A + B) – (C + D)] – pH (actual)

**Table 3 – Water Properties at Saturation**

Temperature °F	Density lb/cu ft	Weight lb/gal	Enthalpy Btu/lb
39	62.43*	8.35	7.04
41	62.43	8.35	9.05
43	62.42	8.34	11.05
45	62.42	8.34	13.06
47	62.42	8.34	15.06
49	62.41	8.34	17.07
51	62.41	8.34	19.07
53	62.40	8.34	21.07
55	62.39	8.34	23.08
57	62.38	8.34	25.08
59	62.37	8.34	27.08
61	62.37	8.34	29.08
63	62.36	8.34	31.08
65	62.34	8.33	33.08
67	62.33	8.33	35.07
69	62.31	8.33	37.07
71	62.31	8.33	39.07
73	62.28	8.33	41.07
75	62.27	8.32	43.06
77	62.25	8.32	45.06
79	62.23	8.32	47.06
81	62.21	8.32	49.05
83	62.19	8.31	51.05
85	62.17	8.31	53.05
87	62.15	8.31	55.04
89	62.13	8.31	57.04
91	62.11	8.30	59.03
93	62.08	8.30	61.03
95	62.06	8.30	63.03
97	62.04	8.29	65.02
99	62.01	8.29	67.02
101	61.98	8.29	69.01
103	61.95	8.28	71.01
105	61.92	8.28	73.01
107	61.89	8.27	75.00
109	61.86	8.27	77.00
111	61.83	8.27	79.00
113	61.87	8.27	80.99
115	61.79	8.26	82.99
117	61.76	8.26	84.99
119	61.74	8.25	86.98
121	61.71	8.25	88.98
123	61.67	8.24	90.98
125	61.64	8.24	92.98
127	61.60	8.23	94.97

\*Maximum water density occurs at 39.2°F

Notes:

1. Absolute constants (US Units) are 231 cu in = 1 gal and 7.4805 gal = 1 cu ft
2. Unless accurate scientific treatment demands otherwise, arbitrary constants utilized in the cooling tower industry are:
  - Water density = 62.34 lb/cu ft
  - Water weight = 8.33 lb/gal
  - 2.31 ft of water column = 1 lb/sq in pressure

**Table 4 – The Properties of Saturated Air**—The wet cooling tower effluent is assumed to be at saturation (100% relative humidity) for all normally expected operating heat loads. Therefore previous references to exit wet-bulbs also relate numerically to exit dry-bulbs.

Temp = temperature °F  
 Enthalpy = Btu/lb of dry air  
 Sp Vol DA = specific volume, ft<sup>3</sup>/lb of dry air  
 Vol Mix = volume, ft<sup>3</sup>/lb mixture  
 Density Mix = lb of dry air per ft<sup>3</sup> of mixture  
 Sp Humid = specific humidity, lb water/lb dry air

Temp	Enthalpy	Sp Vol DA	Vol Mix	Density Mix	Sp Humid	Temp	Enthalpy	Sp Vol DA	Vol Mix	Density Mix	Sp Humid
25.0	8.933	12.276	12.243	0.08167	0.00273	76.0	39.577	13.930	13.663	0.07318	0.01948
26.0	9.316	12.304	12.269	0.08150	0.00286	77.0	40.569	13.970	13.694	0.07302	0.02016
27.0	9.706	12.332	12.295	0.08132	0.00300	78.0	41.585	14.011	13.725	0.07285	0.02086
28.0	10.102	12.361	12.322	0.08115	0.00314	79.0	42.626	14.053	13.756	0.07269	0.02158
29.0	10.505	12.389	12.348	0.08098	0.00329	80.0	43.692	14.095	13.788	0.07252	0.02232
30.0	10.915	12.417	12.375	0.08080	0.00345	81.0	44.785	14.138	13.819	0.07236	0.02309
31.0	11.333	12.446	12.401	0.08063	0.00361	82.0	45.904	14.182	13.851	0.07219	0.02389
32.0	11.758	12.475	12.428	0.08046	0.00378	83.0	47.051	14.226	13.883	0.07202	0.02470
33.0	12.169	12.503	12.454	0.08029	0.00394	84.0	48.227	14.271	13.915	0.07186	0.02555
34.0	12.586	12.532	12.480	0.08012	0.00410	85.0	49.433	14.316	13.947	0.07169	0.02641
35.0	13.009	12.560	12.507	0.07995	0.00427	86.0	50.669	14.362	13.980	0.07152	0.02731
36.0	13.439	12.589	12.533	0.07978	0.00444	87.0	51.936	14.408	14.013	0.07136	0.02823
37.0	13.876	12.618	12.560	0.07961	0.00463	88.0	53.235	14.456	14.046	0.07119	0.02919
38.0	14.320	12.647	12.587	0.07944	0.00481	89.0	54.568	14.504	14.079	0.07102	0.03017
39.0	14.772	12.677	12.614	0.07927	0.00501	90.0	55.935	14.553	14.113	0.07085	0.03118
40.0	15.231	12.706	12.640	0.07910	0.00521	91.0	57.337	14.602	14.147	0.07068	0.03222
41.0	15.698	12.736	12.667	0.07894	0.00542	92.0	58.775	14.653	14.181	0.07051	0.03330
42.0	16.173	12.766	12.694	0.07877	0.00563	93.0	60.251	14.704	14.215	0.07034	0.03441
43.0	16.657	12.796	12.721	0.07860	0.00586	94.0	61.765	14.756	14.250	0.07017	0.03555
44.0	17.150	12.826	12.748	0.07844	0.00609	95.0	63.319	14.809	14.284	0.07000	0.03673
45.0	17.651	12.856	12.775	0.07827	0.00633	96.0	64.914	14.863	14.320	0.06983	0.03794
46.0	18.162	12.887	12.802	0.07810	0.00657	97.0	66.551	14.918	14.355	0.06965	0.03919
47.0	18.682	12.917	12.830	0.07794	0.00683	98.0	68.231	14.974	14.391	0.06948	0.04048
48.0	19.213	12.948	12.857	0.07777	0.00709	99.0	69.957	15.030	14.427	0.06931	0.04181
49.0	19.753	12.979	12.884	0.07761	0.00737	100.0	71.728	15.088	14.464	0.06913	0.04318
50.0	20.304	13.011	12.912	0.07744	0.00765	101.0	73.547	15.147	14.500	0.06896	0.04459
51.0	20.865	13.042	12.939	0.07728	0.00795	102.0	75.416	15.207	14.537	0.06878	0.04605
52.0	21.438	13.074	12.967	0.07711	0.00825	103.0	77.335	15.268	14.575	0.06860	0.04755
53.0	22.022	13.106	12.995	0.07695	0.00856	104.0	79.306	15.330	14.613	0.06843	0.04910
54.0	22.618	13.138	13.022	0.07678	0.00889	105.0	81.331	15.394	14.651	0.06825	0.05069
55.0	23.227	13.171	13.050	0.07662	0.00922	106.0	83.412	15.458	14.690	0.06807	0.05233
56.0	23.847	13.204	13.078	0.07645	0.00957	107.0	85.550	15.524	14.729	0.06789	0.05403
57.0	24.481	13.237	13.106	0.07629	0.00993	108.0	87.745	15.592	14.768	0.06771	0.05577
58.0	25.128	13.270	13.135	0.07613	0.01030	109.0	90.005	15.660	14.808	0.06753	0.05757
59.0	25.789	13.304	13.163	0.07596	0.01068	110.0	92.327	15.730	14.848	0.06734	0.05943
60.0	26.464	13.338	13.191	0.07580	0.01108	111.0	94.714	15.802	14.889	0.06716	0.06134
61.0	27.154	13.372	13.220	0.07564	0.01149	112.0	97.168	15.875	14.930	0.06697	0.06331
62.0	27.858	13.406	13.249	0.07547	0.01191	113.0	99.692	15.950	14.971	0.06679	0.06534
63.0	28.578	13.441	13.277	0.07531	0.01234	114.0	102.288	16.026	15.013	0.06660	0.06744
64.0	29.314	13.476	13.306	0.07515	0.01279	115.0	104.958	16.104	15.056	0.06641	0.06960
65.0	30.067	13.512	13.335	0.07498	0.01326	116.0	107.705	16.183	15.099	0.06622	0.07183
66.0	30.836	13.548	13.364	0.07482	0.01374	117.0	110.531	16.265	15.142	0.06603	0.07413
67.0	31.623	13.584	13.394	0.07466	0.01424	118.0	113.439	16.348	15.186	0.06584	0.07650
68.0	32.427	13.621	13.423	0.07449	0.01475	119.0	116.433	16.433	15.231	0.06565	0.07894
69.0	33.250	13.658	13.452	0.07433	0.01528	120.0	119.514	16.521	15.276	0.06545	0.08147
70.0	34.092	13.695	13.482	0.07416	0.01582	121.0	122.687	16.610	15.322	0.06526	0.08407
71.0	34.954	13.733	13.512	0.07400	0.01638	122.0	125.953	16.701	15.368	0.06506	0.08675
72.0	35.836	13.772	13.542	0.07384	0.01696	123.0	129.318	16.795	15.415	0.06487	0.08952
73.0	36.738	13.810	13.572	0.07367	0.01756	124.0	132.783	16.891	15.462	0.06467	0.09238
74.0	37.662	13.850	13.602	0.07351	0.01818	125.0	136.353	16.989	15.510	0.06447	0.09533
75.0	38.608	13.889	13.633	0.07335	0.01882						

**Table 5 – Recommended Noise Criteria for Offices**

NC Curve of Figure 112 NC Units	Communication Environment	Typical Applications
20-30	Very quiet office; telephone use satisfactory; suitable for large conferences	Executive offices and conference rooms for 50 people
30-50	“Quiet” office; satisfactory for conferences at a 15 ft table; normal voice 10 to 30 ft; telephone use satisfactory	Private or semi-private offices, reception rooms and small conference rooms for 20 people
35-40	Satisfactory for conferences at a 6 to 8 ft table; telephone use satisfactory; normal voice 6 to 12 ft	Medium-sized offices and industrial business offices
40-50	Satisfactory for conferences at a 4 to 5 ft table; telephone use occasionally slightly difficult; normal voice 3 to 6 ft; raised voice 6 to 12 ft	Large engineering and drafting rooms, etc
50-55	Unsatisfactory for conferences of more than two or three people; telephone use slightly difficult; normal voice 1 to 2 ft; raised voice 3-6 ft	Secretarial areas (typing), accounting areas (business machines), blueprint rooms, etc.
Above 55	“Very noisy”; office environment unsatisfactory; telephone use difficult	Not recommended for any type of office

**Note:** Noise measurements made for the purpose of judging the acceptability of the noise in an office by comparison with these criteria should be performed with the office in normal operation but with no one talking at the particular desk or conference table where speech communication is desired (i.e. where the measurement is being made). By permission from “Noise Reduction” by L.L. Beranek, Copyright 1960. McGraw-Hill Book Co.

**Table 6 – Recommended Noise Criteria for Rooms**

Type of Space	Recommended NC Curve of Fig 112 NC Units
Broadcast studios	15-20
Concert halls	15-20
Legitimate theaters (500 seats, no amplification)	20-25
Music rooms	25
Schoolrooms (no amplification)	25
Television studios	25
Apartments and hotels	25-30
Assembly halls (amplification)	25-30
Homes (sleeping areas)	25-30
Motion-picture theaters	30
Hospitals	30
Churches (no amplification)	25
Courtrooms (no amplification)	25
Libraries	30
Restaurants	45
Coliseums for sports only (amplification)	50

**Note:** Noise levels are to be measured in unoccupied rooms. Each noise criterion curve is a code for specifying permissible sound-pressure levels in eight octave bands. It is intended that in no one frequency band should the specified level be exceeded. Ventilating systems should be operating, and outside noise sources, traffic conditions, etc., should be normal when measurements are made. By permission from “Noise Reduction” by L.L. Beranek, Copyright 1960. McGraw-Hill Book Co.

**Table 7 – Factors for Calculating Cold Water Basin Heat Loss**

Ambient Temperature °F	Heat Loss From							
	Water Surface Btu/hr/sq ft	Exposed Basin Sides and Bottom Btu/hr/sq ft				Concrete Basin Sides and Bottom Below Grade Btu/hr/sq ft		
		Plain Steel	Insulated Steel	Wood	Concrete 8" Thick	2'-0 Depth	4'-0 Depth	6'-0 Depth
+ 30	48	20	2	8	12	0.5	0.3	0.2
+ 20	78	40	4	16	23	1.0	0.5	0.3
+ 10	106	60	6	24	35	2.0	1.3	0.8
0	133	80	8	32	47	3.0	2.0	1.3
-10	159	100	10	40	58	4.0	3.0	2.0
-20	185	120	12	48	70	5.0	4.0	3.0
-30	210	140	14	56	82	6.0	5.0	4.0

**Note:** 1. Water surface loss is based on 5 mph wind over water surface under fill. Exposed sides and bottom losses assume a 15 mph wind, and are weighted by orientation of basin surfaces and test experience.  
2. Losses for insulated steel assume at least 1" thick outdoor grade insulation with  $K = 0.30$  Btu/hr/sq ft/°F/in.  
3. Water temperature assumed to be 40°F.

**Table 8 – Heat Loss From Insulated Pipe**

Ambient Temperature °F	Btu per Hour per Linear Foot of Insulted Pipe											
	Nominal Iron Pipe Size inches											
	½	¾	1	1½	2	3	4	5	6	8	10	12
+ 10	3.8	4.7	4.8	6.4	7.3	10.1	12.0	14.7	17.4	21.2	26.0	30.4
0	5.1	6.2	6.4	8.5	9.8	13.4	16.0	19.6	23.3	28.3	34.6	40.4
-10	6.3	7.8	8.0	10.7	12.4	16.8	20.0	24.5	29.1	35.3	43.2	50.6
-20	7.6	9.3	9.6	12.8	14.7	20.2	24.0	29.4	34.9	42.4	51.9	60.7
-30	8.9	10.9	11.2	14.9	17.1	23.5	27.9	34.2	40.6	49.4	60.5	70.8

**Note:** 1. 15 mph wind across insulated pipe.  
2. Water in pipe at 40°F  
3. Rigid pipe insulation, 1" nominal thickness  $K = 0.30$  Btu/hr/sq ft/°F/in.  
4. Estimate heat loss with thicker insulation by reducing table values for 1" thick in direct proportion to increase in thickness (e.g., for 2" use ½ x table, for 3" use ⅓ x table).



**Table 9 – Commonly Used Conversion Factors**

<b>Length or Distance</b>					
<b>Inches</b> in	<b>Feet</b> ft	<b>Miles</b> mi	<b>Centimeters</b> cm	<b>Meters</b> m	<b>Kilometers</b> km
1	0.0833333	0.000158	2.54	0.0254	0.000254
12	1	0.0001894	30.48	0.3048	0.0003048
63360	5280	1	160934.4	1609.344	1.609344
0.3937008	0.0328084	0.0000062	1	0.01	0.00001
39.370079	3.2808399	0.0006214	100	1	0.001
39370.079	3280.8399	0.6213712	100000	1000	1

<b>Area</b>			
<b>Square Inches</b> in <sup>2</sup>	<b>Square Feet</b> ft <sup>2</sup>	<b>Square Centimeters</b> cm <sup>2</sup>	<b>Square Meters</b> m <sup>2</sup>
1	0.0069444	6.4516	0.0006452
144	1	929.0304	0.092903
0.1550003	0.0010764	1	0.0001
1550.0031	10.763910	10000	1

<b>Volume</b>					
<b>Gallons US</b> gal	<b>Cubic Inches</b> in <sup>3</sup>	<b>Cubic Feet</b> ft <sup>3</sup>	<b>Liters</b> L	<b>Cubic Centimeters</b> cm <sup>3</sup>	<b>Cubic Meters</b> m <sup>3</sup>
1	231	0.1336806	3.7854118	3785.4118	0.0037854
0.0043290	1	0.0005787	0.0163871	16.387064	0.0000164
7.4805195	1728	1	28.316847	28316.847	0.0283168
0.2641721	61.023744	0.0353147	1	1000	0.001
0.0002642	0.0610237	0.0000353	0.001	1	0.000001
264.17205	61023.744	35.314667	1000	1000000	1

<b>Velocity</b>					
<b>Feet per Second</b> ft/sec	<b>Feet per Minute</b> ft/min	<b>Miles per Hour</b> mph	<b>Centimeters per Second</b> cm/sec	<b>Meters per Second</b> m/sec	<b>Kilometers per Hour</b> kph
1	60	0.6818182	30.48	0.3048	1.09728
0.0166667	1	0.0113636	0.508	0.00508	0.018288
1.4666667	88	1	44.704	0.44704	1.609344
0.0328084	1.9685039	0.0223694	1	0.01	0.036
3.2808399	196.85039	2.2369363	100	1	3.6
0.9113444	54.680665	0.6213712	27.777778	0.2777778	1

<b>Mass</b>			
<b>Ounce Avoir</b> oz	<b>Pound Avoir</b> lb	<b>Gram</b> g	<b>Kilogram</b> kg
1	0.0759549	28.349523	0.0283495
16	1	453.59237	0.4535924
0.035274	0.0022046	1	0.001
35.273962	2.2046226	1000	1

**Volumetric Flow**

Cubic Feet per Second ft <sup>3</sup> /sec	Cubic Feet per Minute ft <sup>3</sup> /min	Gallons US per Minute gpm	Liters per Second L/s	Cubic Meters per Minute m <sup>3</sup> /min	Cubic Meters per Hour m <sup>3</sup> /hr
1	60	448.83117	28.316847	1.6990108	101.94065
0.0166667	1	7.4805195	0.4719474	0.0283168	1.699008
0.0022280	0.1336806	1	0.0630902	0.0037854	0.227124
0.0353147	2.118880	15.850323	1	0.06	3.6
0.5885778	35.314667	264.17205	16.666667	1	60
0.0098096	0.5885778	4.4028675	0.2777778	0.0166667	1

**Mass Flow**

Pounds per Minute lb/min	Pounds per Hour lb/hr	Kilograms per Minute kg/min	Kilograms per Hour kg/hr
1	60	0.4535924	27.215544
0.0166667	1	0.0075599	0.4535924
2.2046226	132.27736	1	60
0.0367437	2.2046226	0.0166667	1

**Pressure**

Pounds per Square Inch lb/in <sup>2</sup>	Pounds per Square Foot lb/ft <sup>2</sup>	Feet of Water ft-H <sub>2</sub> O	Kilograms per Square Centimeter kg/cm <sup>2</sup>	Pascals Pa	Meters of Water m-H <sub>2</sub> O
1	144	2.306723	0.0703070	6894.7573	0.7030892
0.0069444	1	0.0160189	0.0004882	47.880259	0.0048826
0.4335154	62.42621	1	0.0304792	2988.983	0.3048
14.223343	2048.1614	32.80932	1	98066.5	10.000281
0.0001450	0.0208854	0.0003346	0.0000102	1	0.000102
1.4222946	204.8104	3.2808399	0.0999974	9806.3747	1

**Work or Energy**

British Thermal Units Btu	Kilowatt-Hours kWhr	Horsepower-Hours hp-hr	Foot-Pounds ft-lb	Kilo-Calories kcal	Kilogram-Meters kg-m
1	0.0002929	0.0003928	777.64885	0.2519958	107.51381
3414.4251	1	1.3410221	2655223.7	860.42065	367097.84
2546.1364	0.7456999	1	1980000	641.61557	273744.81
0.0012859	3.77 x 10 <sup>-7</sup>	5.0505051	1	0.0003240	0.1382550
3.9683207	0.0011622	0.0015586	3085.960	1	426.64926
0.0093011	0.0000027	0.0000037	7.2330139	0.0023438	1

**Temperature**

Actual  
 $F = (9/5 \times C) + 32$   
 $C = 5/9 \times (F - 32)$

**Degrees of Range or Approach**

$F = 9/5 \times C$   
 $C = 5/9 \times F$

# Index

Subject	Pages of Interest or Discussion	Applicable Figures	Applicable Formulas
Access.....	26, 37, 40, 47, 52, 80, 87, 104.....	49, 50, 64, 78, 119, 120, 130	
Air Quality .....	30, 31, 33		
Air Velocity.....	9, 24, 25, 26, 33, 53, 55, 56, 89, 94, 99.....	34, 36 .....	(9), (10)
Algae.....	10, 32, 33, 43, 94		
Aluminum .....	29, 49, 53		
Appearance.....	26, 68.....	75	
Approach.....	14, 22, 23, 24 .....	26, 27, 143, 144, 145,146, 147, 148,149	
Atmospheric Towers .....	8, 14.....	2, 3a, 3b	
Blowdown.....	14, 30, 31, 32, 33, 46, 65, 66, 86 .....	40, 128.....	(2), (5)
British Thermal Unit (Btu) .....	14, 18, 19, 77.....	115 .....	(1)
Bronze .....	29, 80		
By-Pass.....	29, 35, 36, 46, 66, 73, 77, 78, 84, 85, 89, 92, .... 93 .....	43, 108, 115,..... 116, 125, 126, 135,138,139	(17)
Capacity Control.....	33, 34, 55, 64, 72, 73, 74, 84 .....	107, 108, 109, 110,111	
Capacity Degradation.....	23, 24, 25, 26, 28, 30, 32, 33, 47, 48, 49, 77,..... 78, 79, 80, 87, 93	37, 38	
Capacity (thermal) .....	14, 19, 20, 21, 22, 23, 55, 99, 101, 102.....	143, 144, 145, .. 146,147, 148, 149	(23), (24), (25)
Casing .....	14, 30, 51, 77, 96.....	49, 75	
Cast Iron .....	29, 45, 54, 58, 80.....	86, 94	
Circulating Water Rate (gpm)	14, 22, 23, 31, 33, 35, 36, 72, 75, 77, 78, 84, ... 99,103.....	28, 142.....	(1), (3), (15), (16), (17), (25)
Codes of Construction.....	29, 30, 37, 38, 41, 52, 57, 61, 95, 99, 104, 105		
Cold Water Temperature .....	14, 67, 72, 73, 74, 77, 83, 89, 99, 103.....	25, 107, 108, .... 109, 110, 111, 115, 116, 124, 125,126	(17)
Collection Basin.....	14, 29, 37, 38, 39, 46, 78, 89, 90, 91, 92, 93, ... 104	44, 49	
Concentrations (TDS) .....	30,31, 32, 33, 103.....	40.....	(2), (5), (6), (7), (8)
Concrete.....	30, 37, 38, 39, 40, 41, 42, 45, 47, 48, 51, 80,.... 95,103.....	44, 46, 50, 53, 54, 55, 56a, 56b, 62	
Copper .....	29		
Counterflow.....	10, 14, 36, 43, 45, 49, 51, 52, 59, 76, 78, 79, ... 95 .....	3a, 4, 8, 16, 41a, 42a, 57	
Crossflow .....	10, 14, 28, 36, 43, 44, 45, 49, 51, 52, 59, 76, .. 80, 81, 95.....	3b, 5, 6, 7, 9, 41b, 42b, 58, 59, 60, 61, 114, 120	
Distribution System .....	10, 11, 14, 28, 33, 35, 42, 43, 47, 48, 52, 53, .... 59, 72, 77, 78.....	56b, 57, 61, 62, 63, 64, 94	
Double-flow.....	11, 14 .....	5, 9	
Drift.....	14, 26, 31, 33, 46, 50, 51, 65, 66, 76 .....	40,114	
Drift Eliminators.....	14, 30, 50, 51, 53, 76, 78, 80, 95, 96 .....	72, 73, 74	
Driveshafts.....	29, 58, 59, 60 .....	90, 91, 92, 93	

Subject	Pages of Interest or Discussion	Applicable Figures	Applicable Formulas
Dry-Bulb Temperature.....	14, 19, 20, 22, 66, 67, 71, 99, 103		
Dry Towers.....	13, 22, 67	98, 99	
Electrical Wiring.....	26, 104		
Energy .....	9, 10, 14, 34, 47, 53, 55, 56, 72, 73, 74, 83,..... 84, 85, 99, 101, 104.....	107, 109, 110, ... 111, 124, 125, ..	(12), (13), (14), (15), (16), (25)
Enthalpy .....	18, 19	18	
Evaluation .....	15, 72, 104		
Evaporation .....	7, 15, 17, 18, 19, 22, 30, 31, 46, 65, 66, 103.....	18, 40	(2), (3), (5)
Factory-Assembled .....	11, 39, 41, 51	11, 12, 51	
Fan-Assisted N.D.....	10, 22	6, 7	
Fan Control .....	See Capacity Control		
Fan Cylinders.....	15, 16, 26, 30, 47, 53, 55, 56, 60, 96.....	67, 68, 95.....	(11)
Fans.....	14, 15, 29, 30, 47, 48, 53, 54, 55, 56, 74, 75, ... 94	68, 79, 80, 81, ... 82, 83, 84, 85.....	(9), (10), (11), (12), (13), (14)
Fats.....	33, 80		
Field-Erected.....	11, 37, 41, 51, 104	3a, 3b, 6, 13, 32, 33, 44	
Fill .....	15, 16, 17, 30, 48, 49, 50, 51, 52, 53, 77, 78, ..... 80, 81, 95, 96	17, 70a, 70b, 71, 74	
Filtration.....	33, 40, 84, 93	125, 139	
Fire Protection .....	29, 33, 39, 49, 51, 52, 80, 95, 96		
Fogging .....	10, 15, 26, 68		
Forced Draft.....	8, 9, 15, 26.....	4, 36	
Foundation.....	37, 38, 39, 104	47	
Free Air Flow.....	26, 37, 48, 50		
Freezing in Operation .....	9, 33, 34, 35, 36, 51, 68, 73, 76, 80, 84, 87	41a, 41b, 42a, 42b, 43	
Freezing at Shutdown .....	84, 87, 89, 90, 91, 92, 95	66, 125, 135, ..... 136, 137, 138	(20), (21), (22)
Handrails.....	29, 52, 87	78, 130	
Heat Load.....	7, 15, 22, 33, 77, 84, 103.....	26, 115.....	(1)
Hot Water Temperature.....	15, 29, 30, 32, 34, 35, 77, 80, 86, 99, 103.....	115, 116, 127, ... 129	(6), (7), (8), (17)
Induced Draft.....	8, 9, 15.....	Many	
Interference .....	15, 23, 26, 28, 47	29, 30, 37, 38	
Ladders .....	29, 52, 87	78, 130	
L/G Ratio .....	15, 19		
Louvers.....	15, 30, 36, 51, 52, 96	41b, 42b, 49, 76, 77	
Lubrication.....	57, 58, 87.....	87	
Make-Up.....	15, 30, 31, 39, 46, 60, 78, 86.....	65, 66, 128	
Mechanical Draft.....	8, 15, 33	Many	
Natural Draft.....	8, 16, 22, 30, 33, 52	3a, 3b	
Noise.....	26, 53, 55, 56, 61, 74, 75	112, 113	
Nozzles.....	16, 30, 43.....	56b, 57, 63, 64	
Oils.....	33, 80		
Overflow.....	46	50	
Owner Responsibility.....	26, 37, 40, 43, 62, 63, 72, 103, 104, 105, 106		
pH.....	16, 30, 32, 33, 80		(6), (7), (8)
Piping.....	16, 26, 28, 30, 43, 44, 45, 46, 82, 89, 91, 92, ... 104.....	39, 58, 59, 60, 63, 64, 130, 137	
Plastics.....	30, 37, 41, 45, 46, 47, 49, 50, 51, 53, 54, 58, ..... 77, 80, 95, 96.....	52, 63, 64, 70b, 71, 73, 74, 81, 92, 93	
Plume Abatement.....	13, 22, 69, 70	101, 102, 103, 104, 105	
Plume Behavior .....	15, 25, 26, 68, 69, 103.....	32, 33, 34	
Plume Management .....	10, 47, 68	3a, 3b, 6, 100	

SECTION X

Subject	Pages of Interest or Discussion	Applicable Figures	Applicable Formulas
Professional Help .....	3, 20, 21, 22, 26, 28, 32, 36, 46, 68, 103		
Protective Coatings .....	29, 38, 39, 45, 48, 49, 51, 54, 55, 58, 80		
Psychrometer.....	16, 20 .....	19, 20, 21	
Pump head.....	10, 16, 43, 72, 89, 92, 104.....		(15), (16)
Range .....	16, 22, 23, 31, 78, 86, 99 .....	26, 28, 143,.....	(1), (3), (17)
		144,145, 146, 147, 148,149	
Recirculation .....	9,11,12,16,19,24,25,26,28,47.....	30, 31, 34, 35, 36, 37, 38	
Rectilinear.....	12,24,25,26,28.....	Many	
Round Towers.....	12,24,25,28,45.....	14, 15, 32, 35, 39	
Safety.....	47, 52, 60 .....	78, 90, 91, 95	
Salt Water Service .....	29, 80		
Single-Flow .....	11, 26, 52.....	10,120	
Slime.....	32, 33, 79, 80 .....	119,120	
Speed Reducers.....	16, 29, 56, 57, 58, 75, 87 .....	86, 88	
Spray-Fill.....	11, 16, 17, 78, 79 .....	2, 16, 117, 118	
Stairways.....	52 .....	Many	
Steel.....	29, 30, 37, 38, 39, 40, 41, 45, 46, 47, 48, 49, 51, 54, 55, 58, 77, 80, 95, 103		
Structural Connectors.....	30,41 .....	52	
Sumps .....	16, 38, 39, 40, 46.....	45, 50	
System Design Concept.....	48, 53, 56		
Tower Orientation.....	25, 26, 28, 75, 82, 104 .....	37, 38, 39	
Tower Testing.....	21, 24, 25, 97, 98, 99, 100, 101, 102, 105.....	142, 143, 144, .. 145, 146, 147, 148,149	(23), (24), (25)
		117,118	
Turbidity.....	78, 93 .....	110,125,126	
Two-Speed Motors.....	34, 61, 73, 74, 75, 84, 85 .....		
	(See "Capacity Control" also)		
Vibration .....	26, 53, 59, 81, 82, 94, 95.....	121, 122, 123, .. 140,141	(18), (19)
Water Conservation.....	3, 13, 22, 65, 66.....	96, 97 et al	
Water Quality.....	29, 30, 31, 32, 39, 50, 76, 84, 85, 93, 103.....		(6), (7), (8)
Wet-Bulb Temperature.....	14, 15, 16, 17, 19, 20, 21, 22, 23, 24, 26, 28, .... 72, 83, 99, 103, 104.....	22, 23, 24, 25, 26, 30, 107, 109, 110, 111, 143, 144, 145, 146, 147, 148, 149	
Windage .....	17		
Wood.....	29, 30, 33, 37, 38, 39, 40, 41, 45, 47, 49, 50,..... 51, 77, 80, 95, 96, 103.....	44, 45, 48, 51, 52, 72, 130	
Wood Treatment .....	29, 38, 49, 51, 80		

The following are registered trademarks of The Marley Cooling Tower Company, Marley Cooling Technologies, Inc. or SPX Cooling Technologies, Inc.

AIR2AIR	GEAREDUCER	PERMAGRID
AQUATOWER	HEXACOOOL	QUADRAFLOW
BALCKE	ISENTRY	QUICKSTACK
BEYOND COOL	MARLEY	RECOLD
CERAMIC	MARPAK	SRC
CLEARFLOW	MODULUS	UNIBASIN
COOLBOOST	NC	XCEL
DRI TOWER	PRIMUS	