

LPC Series product cooler

INSTALLATION - OPERATION - MAINTENANCE

E318714 R0 ISSUED 02/2020

READ AND UNDERSTAND THIS MANUAL PRIOR TO OPERATING OR SERVICING THIS PRODUCT.

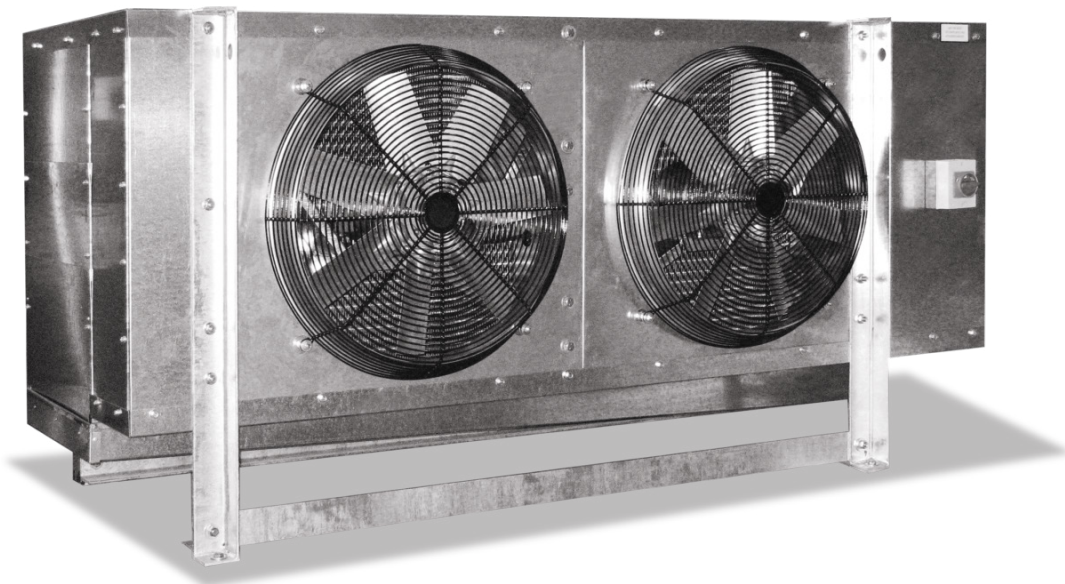

contents

1	Receipt of Equipment	3
1.1	Inspection	3
1.2	Loss of Gas Holding Charge	3
2	Assembly of Components	3
2.1	Shipped Loose Parts	3
2.2	Long Throw Adapter	3
2.3	Water Defrost Splash Guard	3
2.4	Dielectric Flange Union	3
2.5	Refrigerant Distributor Nozzle	3
2.6	Expansion Valve (optional item)	3
3	Rigging Instructions	3
4	Unit Location and Mounting	4
4.1	Unit Location	4
4.2	Mounting	4
5	Refrigerant Warning	6
6	Piping Installation	6
6.1	Drain Line	6
6.2	Refrigeration Piping	7
6.3	Hot Gas Interpiping	7
6.4	Evacuation and Leak Test	7
6.5	DXA and Suction Accumulators	7
7	Electrical	8
7.1	Field Wiring	8
7.2	Electrical Data	8
7.3	Suggested No Defrost Requirement Sequence of Operation	10
7.4	Suggested Air Defrost Sequence of Operation	10
7.5	Suggested Electric Defrost Sequence of Operation	10
7.6	Suggested Hot Gas Defrost Sequence of Operation	11
8	Operation	12
8.1	Pre-Startup	12
8.2	Operation Checkout	12
9	Maintenance	13
9.1	Drain Pan	13
9.2	Coil and Cabinet	13
9.3	Fan Guard or Long Throw Adapter Replacement	13
9.4	Fan Replacement	13
9.5	LPC Type Unit Motor Replacement.....	14
9.6	45° Down Discharge or LPH Type Unit Motor Replacement	14
9.7	Electric Defrost Heaters	14
9.8	Water Defrost Distribution Pan	15
10	Replacement Parts List	16
11	Maintenance Data	18

receiving and installation

1 RECEIPT OF EQUIPMENT

1.1 INSPECTION

All equipment should be carefully checked for damage or shortages as soon as it is received. Each shipment should be carefully checked against the bill of lading. If optional Long Throw Adapters have been ordered, the adapters are shipped loose from the evaporator. When receiving a shipment make sure either the Fan Guards or Long Throw Adapters are delivered with the unit. If any damage or shortage is evident, a notation must be made on the delivery receipt before it is signed and a claim should then be filed against the freight carrier. Inspection and claims are the responsibility of the recipient.

1.2 LOSS OF GAS HOLDING CHARGE

Each copper, steel, and stainless steel tube LPC Series unit is leak tested, evacuated to remove moisture and then shipped with a gas holding charge. Absence of this charge may indicate a leak has developed in transit. The system should not be charged with refrigerant until it is verified that there is no leak, or the source of the leak is located. If the unit contains aluminum tubes or flanged refrigerant connections, the unit is leak tested and evacuated but a gas holding charge is not provided.

2 ASSEMBLY OF COMPONENTS

2.1 SHIPPED LOOSE PARTS

Long Throw Adapters (may be factory mounted)

Water Defrost Splash Guards with required bolts and nuts (may be factory mounted)

Dielectric Flange Union with required bolts, nuts, and gaskets (if the coil contains Aluminum tubes) Special or Extended Legs

Thermal Expansion Valve (may be factory mounted)..

2.2 FAN GUARD OR LONG THROW ADAPTER

Long Throw Adapters are shipped loose. They should be mounted on the unit before the unit is installed. The evaporator fan cabinet contains through-bolts with the threaded end pointing out away from the fan cabinet. The bolts have two 1/2" nuts, flat washers, and a lock washer on them. Remove the outer most nut, lock washer, and one flat washer. Place the Long Throw Adapter on the bolts braced against the remaining flat washer. While holding the adapter with one hand place the flat washers, then the lock washers, and then thread the nuts on the top two bolts to hold the adapter in place. Then place the remaining washers on and thread the other two nuts on the bottom two bolts. Tighten with a wrench..

2.3 WATER DEFROST SPLASH GUARD

If the water defrost splash guard is shipped loose, align the holes in the guard to the holes on the bottom horizontal support angle on the air inlet side of the evaporator. Use the bolts and nuts provided with the splash guard to hold it in place.

2.4 DIELECTRIC FLANGE UNION

Aluminum tube evaporators have aluminum flanged refrigerant connections. A dielectric flange union to attach steel pipe to the aluminum evaporator flange is provided in a separate box. The box should contain dielectric bolt gaskets, bolts, nuts, flange gasket, and mating steel socket weld flange. To avoid material damage during assembly, preweld a length of refrigerant pipe to the steel flange before assembly to the aluminum flange. See Section 6.2 for the aluminum to steel flange assembly drawing.

2.5 REFRIGERANT DISTRIBUTOR NOZZLE

For a direct expansion system, the LPC units already have the distributor nozzle installed. As a check, see that the nozzle is in the distributor, or the auxiliary hot gas tee for direct expansion halocarbon with hot gas defrost, before installing the thermal expansion valve to the distributor or auxiliary hot gas tee.

2.6 EXPANSION VALVE (optional item)

Before hanging a unit with a direct expansion design, install the expansion valve and connect the equalizer tube. The expansion valve should be installed directly to the distributor body or as close as possible with no elbows or bends. Steel expansion valves for ammonia requires the removal of the discharge tube. Locate the expansion valve bulb on a horizontal length of suction line as close to the suction header as possible. Position the bulb in a 3, 4, 8, or 9 o'clock position. Do not position the bulb on the top or the bottom of the pipe. Clamp the bulb down flush and tight against the pipe and insulate. Never locate the bulb on a trap or downstream from a trap.

Expansion valves are NOT adjusted at the factory prior to shipment. It is important that the operation of the expansion valve be checked after the system has balanced out at the desired room temperature. If the coil is being starved it is necessary to reduce the superheat setting of the valve by turning the adjusting stem counter-clockwise. If the superheat is too low it is necessary to increase the superheat setting of the valve by turning the adjusting stem clockwise. It is recommended that for a 10°F to 12°F T.D. system, the valve be adjusted to maintain 5°F to 6°F of superheat.

3 RIGGING INSTRUCTIONS

An LPC Series unit tends to be a long and heavy object with about 2/3 of the weight contained in the coil element at the rear of the unit. Jobsite requirements will affect the method of moving and



receiving and installation

lifting the unit into place. Carefully consider the support that is required to lift and move the unit. Under no circumstances should the shipping skid be used for lifting the unit. To ensure that the unit is not bowed or damaged when being lifted into place from above, all leg or hanger points should be used. If the unit is being lifted into place from underneath, a level support directly under all of the shipping legs is required to adequately steady the unit as it is lifted to the hanger rods.

4 UNIT LOCATION AND MOUNTING

4.1 UNIT LOCATION

Unit must be located to provide good air circulation to all areas. The unit should be positioned to blow away from walls and directed down an aisle, over product, or into product as the room design is specified. For best performance it is desirable to arrange the air discharge toward the door of the room to minimize the entrance of warm moist air when the door is open. If the distance between the LPC unit and a dock door is within the longest third of the unit standard air throw distance, long throw adapters should be considered to keep air velocity up in the door area. Light fixtures, shelving, ceiling structures, and product boxes must be located so that they do not block the air intake or air discharge from the unit.

IMPORTANT—The coil face must be located away from a wall a minimum distance equal to the height of the coil to assure unrestricted air intake.

On all LPC Series units a space should be provided for the possible future replacement of the electric defrost heaters if heaters have been furnished. Table 3 specifies the recommended access dimensions that are needed to remove the heater rods on one or both ends of the unit.

4.2 MOUNTING

The LPC Series units should be suspended with 3/4" diameter threaded STEEL hanger rods. Do not use nylon threaded rods. Rods should have double nuts on the top and bottom. Adequate support must be provided to hold the weight of the unit. Refer to the unit drawing supplied with the unit or the LPC Series catalog for the approximate unit weight and hanger locations. All hanger holes should be used to support the unit. Do not temporarily support a unit using less than all hanger or shipping leg holes. The shipping support legs can be removed after the unit is hung. If the LPC Series unit is floor or platform mounted, anchor the unit through the holes in the pads at the bottom of each support leg. See unit drawing for mounting hole locations. If the refrigeration system is direct expansion, the distributor orifice and expansion valve should be in place before the unit is hung. See Sections 2.5 and 2.6.

The unit must be level in all directions to insure proper drainage of the condensate drain pan. Suspended units must have sufficient clearance above for cleaning the top of the unit and repairing the Water Defrost assemblies, if provided.

Table 1 – Unit Physical Data

Base Model	Rows Deep	Face Area sq ft	Fans	Approximate Weight lb			Coil Volume cu ft	Total Surface sq ft		Water Defrost gpm	Drain Size	
				Steel	CU/SS	ALUM		3 FPI	4 FPI		STD	WD
166	6	16.0	2 x 24"	1800	1100	850	1.5	1151	1425	18	2"	3"
168	8			2200	1250	1000	2.0	1534	1899	24		
1610	10			2500	1400	1100	2.5	1918	2374	28		
346	6	32.1	4 x 24"	3400	2000	1700	3.0	2302	2848	36	2"	3"
348	8			4400	2300	1900	4.0	3068	3796	48		
3410	10			5300	2600	2100	5.0	3836	4748	56		
426	6	40.1	5 x 24"	4000	2500	2100	3.8	2877	3560	54	2"	
428	8			4850	2800	2400	5.1	3835	4747			
4210	10			5700	3100	2600	6.3	4795	5935			
496	6	48.2	6 x 24"	4400	2800	2600	4.6	3453	4272	72	2"	5"
498	8			5600	3100	2800	6.1	4602	5697	84		
4910	10			6700	3400	3000	7.6	5754	7122	96		

installation

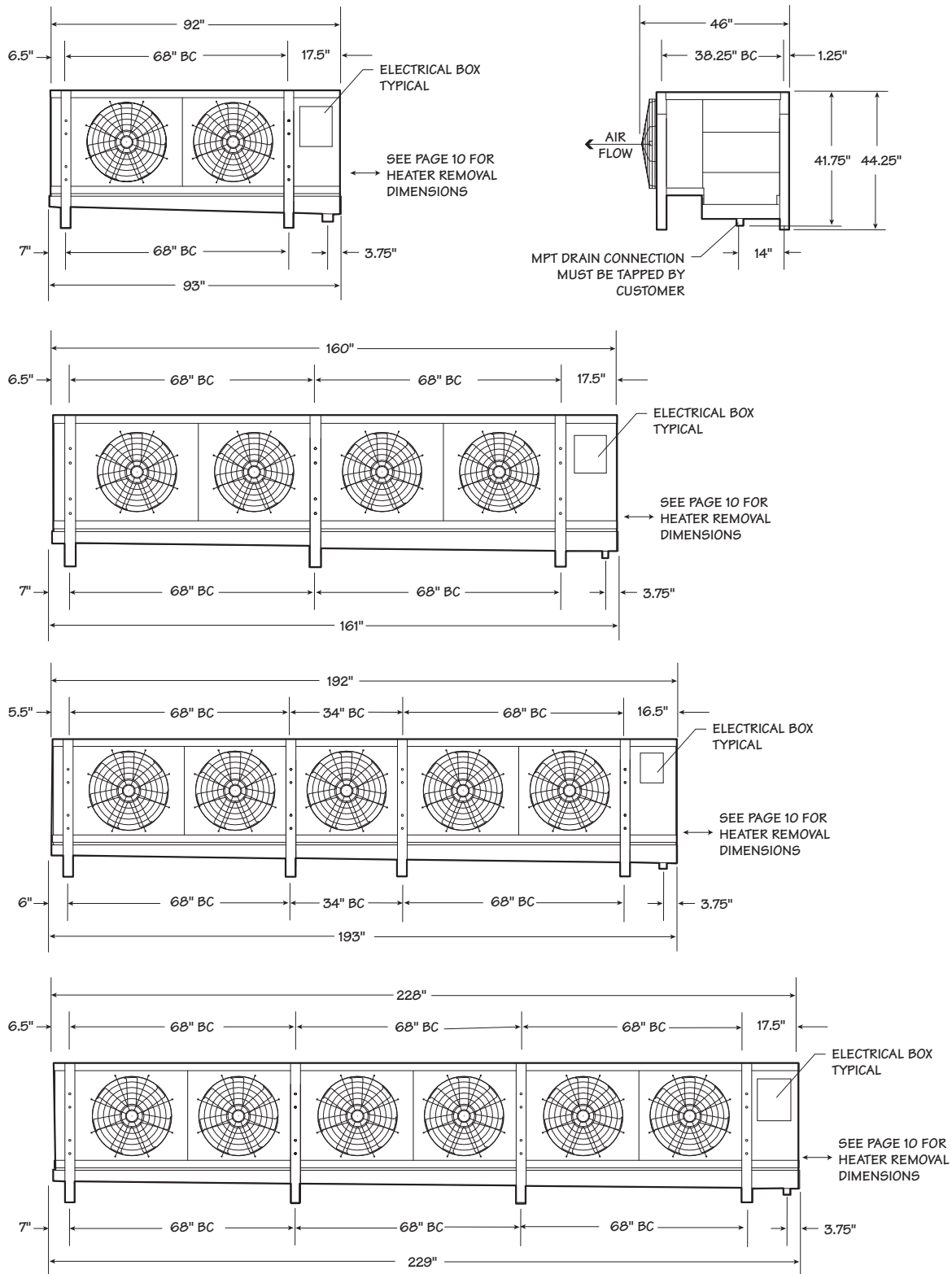

FIGURE 1 Unit Dimensions

installation

5 REFRIGERANT WARNING

The use of any refrigerant can be dangerous under certain conditions. Where people or product can be exposed to hazardous conditions, daily inspections should be made for the detection of any defect or malfunction that could cause the escape of the refrigerant and cause harm. In the case of halocarbon refrigerants, electronic detection devices are available for sensing the presence of such refrigerants in the atmosphere.

Ammonia is a "self-alarmed" gas with its strong odor but detection devices are strongly recommended. People and product are a concern based on the concentration levels (ppm) of ammonia along with OSHA and EPA regulations. An ammonia gas detection device connected to an external alarm system to warn that a leak is occurring is recommended. Refer to local codes and Fire Department for additional local regulations.

Only experienced, qualified personnel should install, operate, and maintain detection and alarm equipment.

6 PIPING INSTALLATION

6.1 DRAIN LINE

The drain line should be as short and as steeply pitched as possible with a minimum of 1/4" drop per running foot. The drain line

should be the same size, or larger, as the drain pan connection. A drain line trap should be installed to prevent warm moist air from migrating through the drain line. The trap should be located in the warmest and/or lowest section of the piping to avoid freezing and provide sufficient liquid head for flow through the trap. If the temperature surrounding the drain line is below freezing (32°F) it must be wrapped with a drain line heater and insulation. Be sure to also wrap the drain pan coupling. The drain line heater should be energized continuously, but to avoid the possibility of overheating, heat tape manufacturers recommend a thermostat be installed. Be sure to follow the manufacturer's recommendations. The drain line trap should be outside of the freezing space. See Figure 2.

A union at the drain pan connection is recommended for future servicing. The union should be located just outside the edge of the drain pan so that when the pan is lowered for cleaning or repair the drain line run is not in the way. Use two wrenches when tightening to prevent the drain fitting from twisting and damaging the drain pan. See Figure 3.

Long runs of drain line, i.e. more than a few feet, should be supported by hangers to avoid damage to the drain pan. For cleaning and inspecting the drain, tees with plugs are recommended instead of elbows.

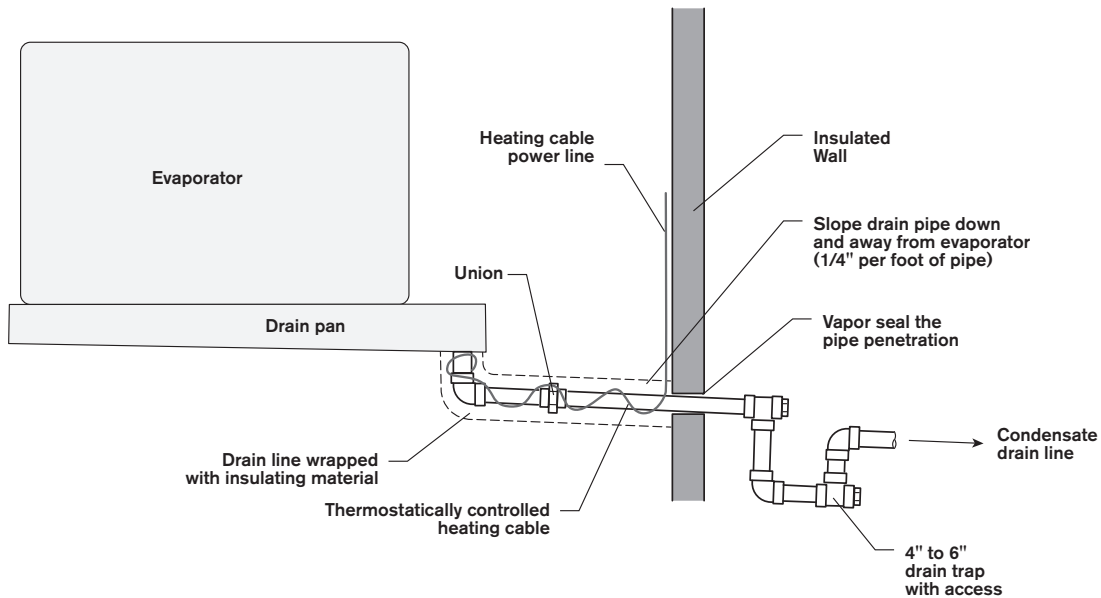

FIGURE 2 Drain Line

installation

6.2 REFRIGERATION PIPING

Installation design must conform to all local and national codes, laws and regulations applying to the site of installation. In addition, safety codes for mechanical refrigeration, IIR-2, ANSI/ASHRAE Std. 15, and ASME B31.5, should be followed as a guide to safe installation and operation practice.

Refrigerant line sizes, piping support, and piping techniques should be obtained from published recognized refrigeration standards. Under no circumstances should the refrigerant connection size of the unit be used as the basis for sizing the lines.

IMPORTANT—The LPC Series units have not been designed to carry the weight of any external piping or valves. Improper support of external piping and valves may result in unit breakage and refrigerant spillage.

The horizontal suction line should slope away from the unit. Vertical suction risers on halocarbon systems require a properly sized “P” trap at the foot of the riser for proper oil return, and thermostatic expansion valve operation.

Aluminum tube units will have aluminum flanged refrigeration connections. Steel Companion flanges with bolts, nuts, and gaskets are shipped loose with the unit. Weld the steel flange to the refrigeration piping or a long stub before bolting to the aluminum flange to avoid heat damage to the aluminum flange and gaskets. See Figure 4 for an assembled view of the aluminum/steel connection.

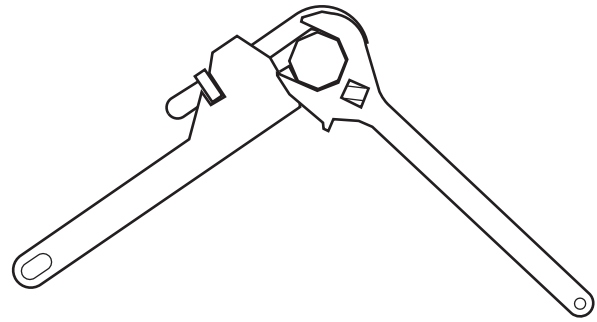

FIGURE 3 Pipe Joining

6.3 HOT GAS INTERPIPING

If the unit was ordered with hot gas defrost the drawing shipped with the unit will contain the piping connection locations for the hot gas inlet and the condensate relief.

6.4 EVACUATION AND LEAK TEST

When all refrigeration connections have been completed, the entire system must be tested for leaks and then evacuated.

6.5 DXA AND SUCTION ACCUMULATORS

Do not use units with Direct Expansion Ammonia (DXA) feed below 0°F evaporating temperatures unless the compressor system is designed and protected to handle the overfed liquid by use of a suction accumulator.

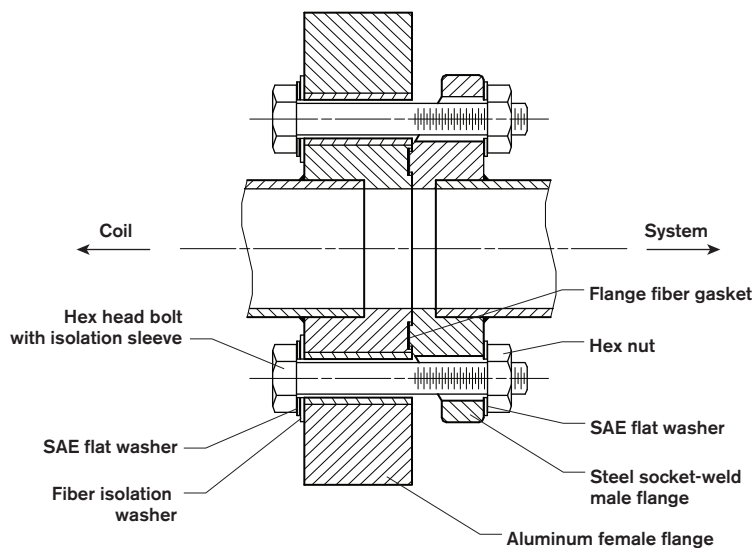

FIGURE 4 Aluminum Flange Assembly

installation

7 ELECTRICAL

FOR SAFETY BEFORE SERVICING:

If the LPC Series unit is equipped with an electrical power disconnect switch make sure the switch is in the "OFF" position before working on the unit, preferably locked out in this position..

7.1 FIELD WIRING

Field wiring should comply with NEC and local codes. The power supply voltage, phase and frequency must match what is shown on the unit data plate. Wire motors so that the fan rotation is counter-clockwise.

Wiring for a unit with Air or Hot Gas, without a SGS mounted electrical panel, requires power to the fan motor terminal block only. The fan motor terminal block is located in the electrical panel on the refrigerant connection end of the unit. If the unit is supplied with Electric Defrost, but no control panel, wiring will be required to the mounted terminal block in the electrical enclosure for both the motor(s) and defrost heaters. See Figure 5 for typical Air Defrost unit wiring or Figure 6 for Electrical Defrost unit wiring 230/380/460/575/3/60 power. If a SGS mounted control panel is provided, wiring to only one set of terminal blocks is required. See wiring diagram supplied with unit.

Table 2 – Motor Electrical Data					
Fan Motor Nameplate Total Full Load Amps					
Motor hp	RPM	208/3/60	460/3/60	380/3/50	575/3/60
.50	1140	2.2	1.1	1.1	1.0*
1.0	1140	3.8	1.9	1.9	1.5*
1.5	1725	4.8	3.0	3.0	2.2
2.0	1725	6.0	3.0	3.0	2.2

7.2 ELECTRICAL DATA

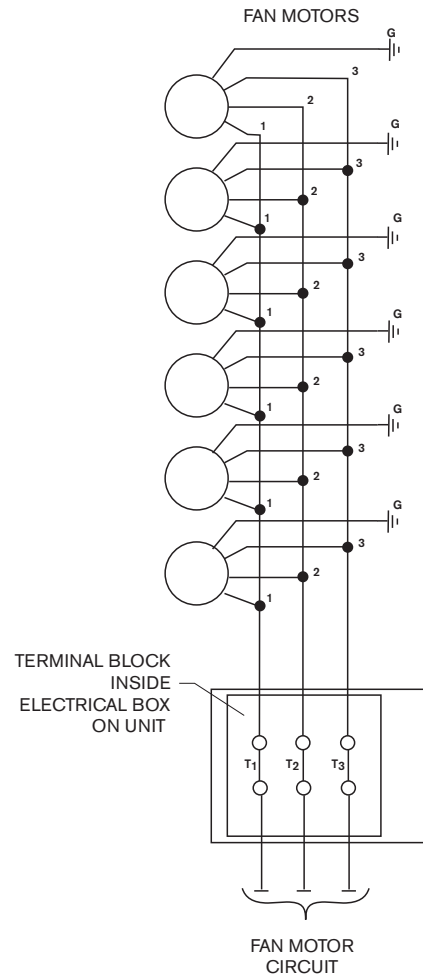

FIGURE 5 Air Defrost Wiring

Table 3 – ED and EDL Electrical Defrost Heater Data

Model	ED						EDL						Heater Removal Dimensions	
	Total kW		Total Amps		Total kW	Total Amps	Total kW		Total Amps		Total kW	Total Amps		
	230/460/575V	230V	460V	575V	380V	380V	230/460/575V	230V	460V	575V	380V	380V	Header End	Return End
166	7.2	18.1	9.0	7.2	6.6	10.0	12.5	31.4	15.7	12.6	11.4	17.3	53"	
168	10.8	27.1	13.6	10.8	9.8	14.9	16.1	40.5	20.2	16.2	14.7	22.3	53"	
346	14.4	36.1	18.1	14.5	13.1	19.9	24.6	61.7	30.9	24.7	22.4	34.0	53"	58"
348	21.6	54.2	27.1	21.7	19.7	29.9	31.8	79.8	39.9	31.9	28.9	43.9	53"	58"
426	18.0	45.2	22.6	18.1	16.4	24.9	30.5	76.6	38.3	30.6	27.8	42.2	70"	77"
428	27.0	67.8	33.9	27.1	24.6	37.3	39.5	99.2	46.6	39.7	36.0	54.6	70"	77"

installation

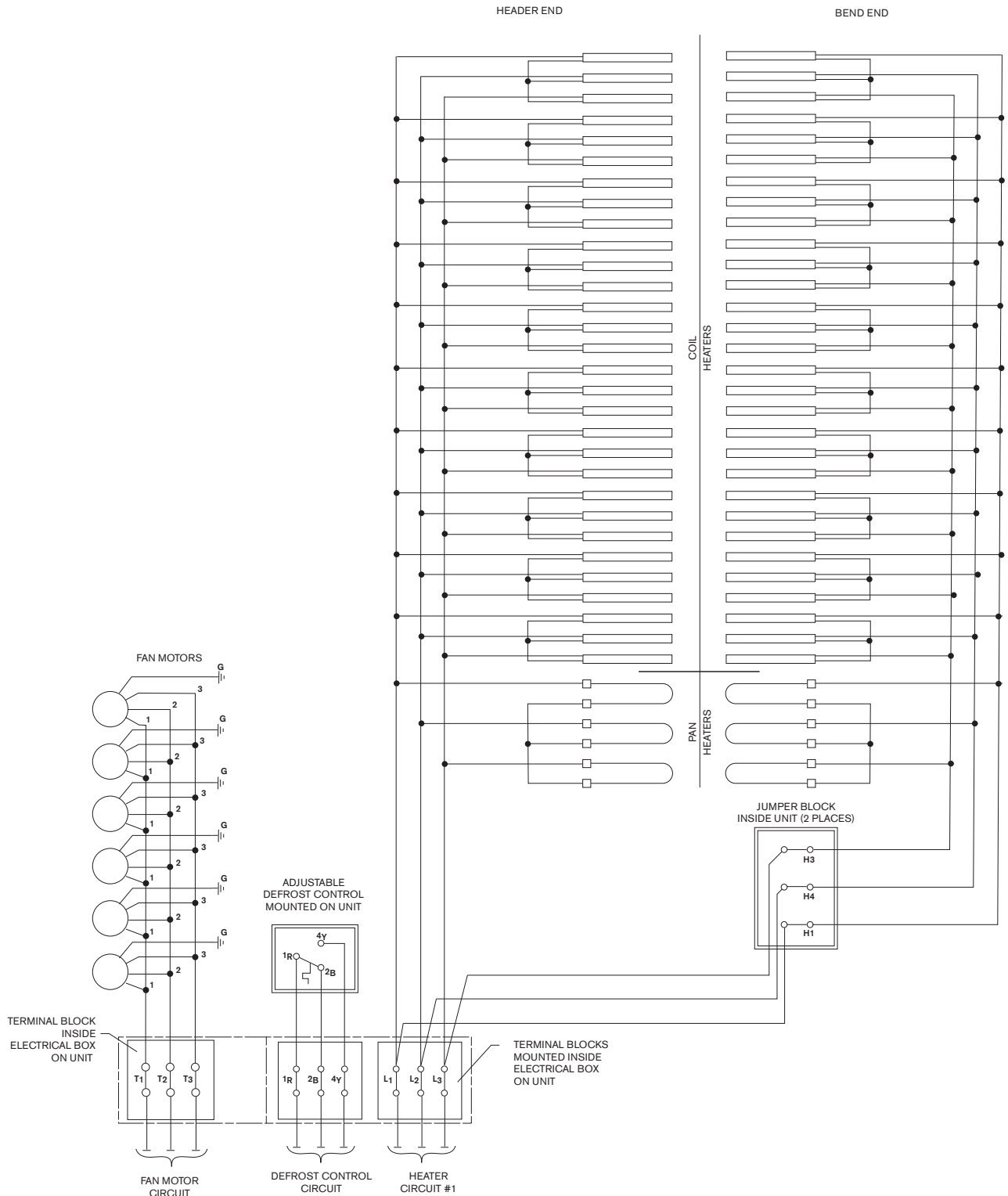

FIGURE 6 Electrical Defrost Wiring 230/380/460/575/3/60

installation

7.3 SUGGESTED NO DEFROST REQUIREMENT SEQUENCE OF OPERATION

Used for units with a suction temperature above freezing.

- A. When the room thermostat calls for cooling, refrigerant begins flowing to the unit.
- B. The fan motors are energized.
- C. When the thermostat is satisfied, refrigerant stops flowing to the unit.
- D. The fan motors are de-energized.

7.4 SUGGESTED AIR DEFROST SEQUENCE OF OPERATION

Used for units with a suction temperature below freezing, but a room temperature above 36°F.

- A. A defrost timer is wired into the fan motors control.
- B. The timer turns off the liquid line solenoid valve at a predetermined time, but the fan motors continue to operate.
- C. When the refrigerant is completely boiled out of the unit, the fan motors still continue to operate so that the room air temperature melts the coil frost.
- D. At a second predetermined time, the timer energizes the liquid solenoid valve and refrigeration resumes.

The timer settings are to be programmed per the need of each evaporator.

7.5 SUGGESTED ELECTRIC DEFROST SEQUENCE OF OPERATION

Used for units with a suction temperature below freezing. The Electric Defrost cycle is time clock initiated and temperature terminated. Three or four defrost cycles per 24 hour period are typical. The following sequence is based on the Paragon 8145 or equal time clock.

- A. Power is supplied to the defrost timer.
- B. The defrost termination thermostat is off and the defrost heaters are off.
- C. The unit operates in cooling mode.
- D. Upon initiation of the defrost cycle the time clock turns off the liquid line solenoid valve.
- E. After a site determined time period the timer de-energizes the fan motors and energizes the defrost heaters.
- F. The heaters, positioned within the coil turbo spacers in the fin pack, heat up the fins directly to melt the accumulated frost.
- G. When the coil reaches the temperature setting of the defrost termination thermostat the thermostat opens the defrost circuit to cut off power to the heaters.
- H. The defrost timer energizes the liquid line solenoid valve allowing refrigerant to flow into the unit, cooling the coil and refreezing any remaining condensate drops that are still present.
- I. The fan motors are started through the fan delay thermostat temperature setting, putting the unit in the cooling cycle.

The timer settings and the adjustable defrost termination fan delay thermostat settings are to be programmed per the need of each evaporator.

installation

7.6 SUGGESTED HOT GAS DEFROST SEQUENCE OF OPERATION

Used for units with a suction temperature below freezing. The Hot Gas Defrost cycle is time clock initiated and terminated. The following sequence is based on the Hansen Frost Master or equal time clock.

- A. Power is supplied to the defrost timer.
- B. The unit operates in the cooling cycle.
- C. Upon initiation of the defrost cycle, the defrost time clock turns off the liquid line solenoid valve. The fan motors continues to operate to boil off the remaining refrigerant in the coil tubes.
- D. After a predetermined time period the defrost timer de-energizes the fan motors and energizes the hot gas supply solenoid valve. Note that larger units may also have a "soft defrost" solenoid to slowly pressurize the coil, which will open before the main hot gas supply solenoid.
- E. Hot gas flows into the unit and warms up the tubes and fins (and drain pan if a hot gas pan was supplied), melting the accumulated frost.
- F. Approximately eight to twelve minutes after starting the hot gas defrost cycle the defrost time clock should de-energize the hot gas supply solenoid valve. If the unit is in defrost for a much longer period of time the condensate on the tubes and fins could "steam" and refreeze on the fan cabinet, fans, or venturi causing maintenance problems.
- G. The defrost time clock should energize the vent solenoid, allowing any remaining high-pressure gas to escape the coil.
- H. The defrost timer energizes the liquid line and suction line solenoid valves allowing refrigerant to flow into the unit, cooling the coil and refreezing any remaining condensate drops that are still present.
- I. The fan motors are energized after a preset fan delay in the time clock and the unit is in the cooling cycle.

The timer settings are to be programmed per the need of each evaporator.

operation

8.0 OPERATION

8.1 PRE-STARTUP

After the installation is completed, a review of the following items should be performed before the system is placed into operation:

- A. Check electrical connections, fan bushing set screws, motor mount bolts, coil flange bolts, drain pan flange bolts, and all other fasteners for tightness. If required, be sure the thermostatic expansion valve bulb is properly located, strapped, and insulated.
- B. For systems with a defrost time clock check the timer to see that it is set for the correct time of day and the starting pins have been installed (normally two or three sets per day). Defrost should be scheduled when the freezer doors are not likely to be open.
- C. When the unit is first started the room temperature is typically above the contact closing temperature of the fan delay thermostat, if a fan delay thermostat is provided for Electric Defrost units (see that particular units electrical diagram). The fans may remain off for a lengthy period of time. To prevent this delay it is permissible to install a temporary jumper wire between terminals "1R" and "2B". Once the room temperature is below +25°F the jumper wire should be removed.
- D. For PH style units make sure that the grease lines to the bearings are filled with grease. See Maintenance section 9.5 or 9.6 for recommended grease types. The motors for LPC units are greased from the motor manufacturer.

8.2 OPERATION CHECKOUT

With the system operating, check the supply voltage. The voltage must be within +/- 10% of the voltage marked on the unit nameplate and the phase to phase unbalance should be 2% or less.

LISTEN CAREFULLY to the unit to make sure there are no unusual sounds. Sounds such as a noisy motor, the fans scraping on the housing, or loose fasteners allowing parts to rattle need to be addressed immediately before continued unit operation.

Check the room THERMOSTAT setting. Be sure it functions properly.

For RECIRCULATED refrigeration systems the hand expansion valve should be opened slowly until either condensate or frost forms on the return bends from the bottom to the top of the coil. A good indicator is when the defrost relief valve reads 5 PSI above suction pressure.

For FLOODED refrigeration systems check to make sure the float valve is working properly and allows refrigerant into the drum to the appropriate level when the level is sufficiently low. If a hand expansion valve has been added, the valve should be set to allow liquid make up 70% of the time.

For DIRECT EXPANSION systems let the system balance out at the desired room temperature and check the operation of the expansion valve by properly measuring the superheat at the sensing bulb. As much as thirty minutes may be required for the new balance to take place after an adjustment is made.

For BRINE or WATER COOLING systems keep the closest vent to the coil open while the fluid fills the coil to allow trapped air to escape. Close the vent valve once fluid flows out of the valve and check for water hammer in the coil.

With HOT GAS DEFROST systems allow the coil to frost, then manually advance the defrost timer to initiate a defrost cycle. Observe the defrost cycle to see if all controls are functioning properly and that the coil is clear of all frost before the system returns to refrigeration. Adjust the time clock pins if necessary. Reset the defrost timer to the correct time of day. A defrost cycle is only needed when the frost build up is such that it impedes the airflow through the coil. The defrost requirements will vary on each installation and may change depending on the time of the year and other conditions.

With ELECTRIC DEFROST systems allow the coil to frost then manually advance the defrost timer to initiate a defrost cycle. Observe the defrost cycle to see if all controls are functioning properly and that the coil is clear of all frost before the system returns to refrigeration. Adjust the time clock pins if necessary. Reset the defrost timer to the correct time of day. A defrost cycle is only needed when the frost build up is such that it impedes the airflow through the coil. The defrost requirements will vary on each installation and may change depending on the time of the year and other conditions.

maintenance

9 MAINTENANCE

A preventive maintenance schedule should be established as soon as the LPC Series unit is installed. The unit should be inspected periodically for proper operation and build up of frost and debris.

WARNING: All power to the evaporator must be off before cleaning or performing maintenance.

9.1 DRAIN PAN

Inspect and clean the drain pan to insure free drainage of condensate. The drain pan should be cleaned regularly with warm water and soap.

If the drain pan needs to be removed, support the long dimension of the pan from underneath with a minimum of two 4x4s for one and two fan units, or two 6x6s for three and four fan units, so the outer sheet metal skin does not buckle and become damaged. Do not point load the center of the support beam. For longer pans more than one lifting device may be needed to keep the pan balanced when lifting. If the drain pan uses hot gas defrost make sure the coil is completely pumped out and isolated with hand valves to prevent refrigerant from escaping to the atmosphere. Remove the hot gas piping or electric wires if the unit has a Hot Gas or an Electric Defrost drain pan. Remove the drain line so that it is out of the way of the pan when it is being lowered. Remove the drain pan attachment bolts from the bottom of the evaporator unit and slowly lower the pan from the unit. Assemble pan in reverse order. Replace hot gas interpipng gaskets before tightening flange bolts.

9.2 COIL AND CABINET

Clean the coil, fan cabinet, fans, and fan guards with warm water and soap. A low-pressure water hose is recommended to avoid water entering into electrical components and causing equipment failure.

The evaporator coil should be checked once a month for proper defrosting. Many variables affect coil frosting such as room temperature, type of product being stored or processed, how often new product is

LPC Low Profile Product Coolers (E318714 R0) brought in, and the length of time the door to the room remains open. Summer conditions of high humidity can cause heavier frost loads and it may be necessary to change the number of defrost cycles seasonally.

9.3 AN GUARD OR LONG THROW ADAPTER REPLACEMENT

To remove a fan guard or long throw adapter for fan-motor maintenance, or for guard or adapter replacement, make sure all electrical power to the unit has been turned off before any work is performed. Remove the two nuts on the lowest part of the guard or adapter first. While holding the guard or adapter to the unit with one hand use your other hand to remove the top two nuts. Use both hands to remove the guard or adapter. Reassemble in the reverse order.

9.4 FAN REPLACEMENT

If a fan is out of balance, damaged, or needs to be replaced, the unit does not need to be at floor level for maintenance. Make sure all electrical power to the unit has been turned off before any work is performed. Remove the fan guard as described in Section 9.3. Remove the two or three bolts from the bushing that hold the fan onto the motor shaft. Insert the bolts that were just removed into the auxiliary holes in the fan bushing. Insert a small, thin piece of metal, like a dime or similar thickness, between the end of the bolt and the fan hub. By tightening the bolts against the hard metal and the hub the bushing will be pulled from the motor shaft. Remove the bushing, fan, and key. Clean and deburr the motor shaft, key, and keyway if necessary.

Place the new fan onto the motor shaft so that the fan blades cup the air away from the coil, all the way to the motor body. Typically the center hub of the fan has an extension that should point towards the motor. Align the keyway on the taper-lock bushing and the motor shaft. Insert the key and tap the key and the bushing onto the motor shaft until they are flush with the end of the motor shaft. Rotate the fan until the non-threaded holes in the bushing align with the threaded holes in the fan hub. Insert new bolts through the holes in the bushing. Evenly tighten the bolts, drawing the fan over the bushing. The bushing should be flush with the motor shaft when finished. Tighten the bolts to 14 ft-lbs. When the bolts are tight, tap the key with a punch to make sure the key is tight. Reattach the fan guard or adapter.

IMPORTANT: If the key slips, remove the fan and start over, possibly with a new key and bushing. If the key is not tight the fan may come off on startup, or during operation causing damage.

maintenance

9.5 LPC TYPE UNIT MOTOR REPLACEMENT

When greasing the motor use Chevron RPM Arctic, Esso Beacon #325, or equivalent grease. Use a low-pressure grease gun to avoid over lubrication or destruction of the bearing seals.

Make sure all electrical power to the unit has been turned off before any work is performed. To replace a motor a lifting device may be required for the heavy motors. Remove the fan guard and fan as described in Sections 9.3 and 9.4. Remove the motor junction box cover and disconnect the motor leads.

If the motor being removed is the same frame size as the replacement motor, use a pencil to trace an outline on the unit motor mount for the replacement motor installation. For safety, the motor should be supported before the hold down bolts and nuts are taken apart. Remove the motor hold-down bolts and remove the motor from the housing.

Remove the motor junction box cover. Set the replacement motor in place using the pencil marks as a guide. Connect the wires to the motor following the wiring schematic for the motor. Make certain the motor is wired for the correct supply voltage. Attach the motor junction box cover. Measure from the shaft center to the outside of the fan orifice at several angles. The motor shaft should be centered. If the motor is too low, shim the base up with washers or use a motor base conversion kit if the frame sizes are different. If the motor is too high, the motor mount will need to be lowered in the fan cabinet.

When the motor shaft is centered, insert the bolts and nuts to hold the motor in place. Only slightly tighten the bolts at this time in case the motor needs to be adjusted after the fan is installed.

Place the new fan, with the numbers cast on the fan hub toward the installer, onto the motor shaft all the way to the motor body. Align the keyway on the taper-lock bushing and the motor shaft. Insert the key and tap the key and the bushing onto the motor shaft until they are flush with the end of the motor shaft. Rotate the fan until the non-threaded holes in the bushing align with the threaded holes in the fan hub. Insert new bolts through the holes in the bushing. Evenly tighten the bolts, drawing the fan over the bushing. Tighten the bolts to 14 ft-lbs. When the bolts are tight, tap the key with a punch to make sure the key is tight. Reattach the fan guard or adapter.

IMPORTANT: If the key slips, remove the fan and start over, possibly with a new key and bushing. If the key is not tight the fan may come off on startup, or during operation causing damage.

The fan-motor assembly should already be aligned to have equal clearance between the tip of the fan blades and the sheet metal orifice. Position the fan-motor assembly so that the blades are recessed one inch from the front edge of the orifice, which is roughly in the center of the orifice. Complete tightening the fan-motor assembly bolts and nuts to the mounting base. Replace the fan guard or adapter as described in Section 9.3.

When starting the motor make sure the fan is rotating in the proper counter clockwise direction. If the fan rotates clockwise, stop the motor, shut off all power to the unit, and change the motor wiring for counter clockwise rotation.

9.6 45° DOWN DISCHARGE OR LPH TYPE UNIT MOTOR REPLACEMENT

When greasing the motor use Chevron RPM Arctic, Esso Beacon #325, or equivalent grease. Use a low pressure grease gun to avoid over lubrication or destruction of the bearing seals.

Replacing a motor for a 45° Down Discharge or LPH type of unit is basically the same as in Section 9.5, with the following extra precautions:

- Extra care should be taken to avoid the motor and/or fan from falling down through the air discharge, causing harm or damage.
- The motor should be supported through the access plate directly above the motor in the fan cabinet.
- The heavy fan should be supported before and during the taper-lock bushing removal or installation.
- The motor base bolts and nuts should be fully tightened whenever they are installed.
- The grease line to each motor needs to be removed when removing the motor and reattached when the motor is installed.

maintenance

9.7 ELECTRIC DEFROST HEATERS

Inspect the electric defrost heater ends to determine if they are operating. A heater will be operating properly when the heater is observed to be glowing during the defrost cycle. If a heater rod is cold during the defrost cycle it will need to be replaced.

Coil heaters require horizontal removal from one end of the unit. On two or three fan unit heater rods are on both ends of the unit. Remove heater wire from terminal block and note where original wires were located. Rotate the heater rod so that the heater and retainer clip can be slid through the coil endplate slot. Remove clip from the old heater rod and install on the new heater rod in approximately the same location as the original heater. Install new heater rod in the coil original coil slot, rotate the rod 90°, and replace the wires in the positions of the original wires in the terminal block. Drain pan heaters require the drain pan to be removed. Support the long dimension of the pan from underneath with a minimum of two 4x4s for one and two fan units or two 6x6s for three and four fan units so the outer sheet metal skin does not buckle and become damaged. For longer pans more than one lifting device may be needed to keep the pan balanced when lifting. Remove the heater wires from the terminal blocks. Remove the drain line so that it is out of the way of the pan when it is being lowered. Remove the drain pan attachment bolts from the bottom of the evaporator unit and slowly lower the pan from the unit. Remove the nuts from the heater hold down brackets and remove the brackets. Replace the heater. Replace the hold down brackets and assemble the pan in reverse order. Rewire the heaters in the original terminal blocks.

9.8 WATER DEFROST DISTRIBUTION PAN

The Water Defrost distribution pan is removable from the rear of the unit for cleaning or replacement. Disconnect the water piping from the pan inlet connection. Remove the access plate from the front of the water pan section and slide out the water distribution pan. Reassemble in the reverse order.

maintenance

10 REPLACEMENT PARTS LIST

Following are the major replacement parts of the standard LPC Series units. Call sales representative or factory to identify non-standard replacement parts. The full Model Number, Serial Number, and voltage will be necessary to identify the correct replacement part.

Description	.5 hp – 1160 rpm	1 hp – 1160 rpm	1.5 hp – 1750 rpm	2 hp – 1750 rpm
Motor 230/460/3	E312655	11082	E312631	E312405
Fan	E315872	E315873	E316543	E315874
Bushing	E315866	E315866	E315866	E315866
Fan Guard	E82691			
Long Throw Adaptor	CE321143			
Pan Panel – Mill Gavanized	E82691			

Drain Pan Type	Models			
	16	34	42	49
Drain Pan Dimensions	23.5"x94"	23.5"x162"	23.5"x194"	23.5"x230"
Aluminum (A, HGC, ED) Non-Insulated	CE320207	CE320208	CE320594	CE320209
Aluminum (A, HGC, ED) Insulated-Galvanized Cover	CE320203	CE320204	CE320586	CE320205
Aluminum (A, HGC, ED) Insulated-Stainless Cover	CE320015	CE321162	CE321166	CE321170
Aluminum (230V-EDL) Insulated-Galvanized Cover	CE320781	CE320783	CE320724	
Aluminum (460V-EDL) Insulated-Galvanized Cover	CE320782	CE320784	CE320725	
Aluminum (230V-EDL) Insulated-Stainless Cover	CE303818	CE303850	CE303866	
Aluminum (460V-EDL) Insulated-Stainless Cover	CE303819	CE303851	CE303867	
Stainless Waffle (HGP/HGS) Insulated-Galvanized Cover	CE320009	CE320010	CE320583	CE320011
Stainless Waffle (HGP/HGS) Insulated-Stainless Cover	CE321154	CE321160	CE321164	CE321168

maintenance

Table 6 – ED and EDL Heater Replacement Parts

Model	Number of Fans	Total Quantity		Coil Heaters							
				230V		460V		380V		575V	
		ED Coil Heater	EDL Coil Heater	Part Number	Watts	Part Number	Watts	Part Number	Watts	Part Number	Watts
LPC166	2	6	9	E311562	1200	E311099	1200	E311562	1092	E315484	1200
LPC168	2	9	12	E311562	1200	E311099	1200	E311562	1092	E315484	1200
LPC346	4	12	18	E311562	1200	E311099	1200	E311562	1092	E315484	1200
LPC348	4	18	24	E311562	1200	E311099	1200	E311562	1092	E315484	1200
LPC426	5	12	18	17785	1500	17782	1500	17785	1365	E315471	1500
LPC428	5	18	24	17785	1500	17782	1500	17785	1365	E315471	1500

Model	Number of Fans	Total Quantity		Drain Pan Heaters							
				230V		460V		380V		575V	
		EDL Pan Heater	Part Number	Watts	Part Number	Watts	Part Number	Watts	Part Number	Watts	
LPC166	2	3	E312205	575	E312206	575	E312205	523	E315485	575	
LPC168	2	3	E312205	575	E312206	575	E312205	523	E315485	575	
LPC346	4	6	21760	498	21766	498	21760	453	E315477	498	
LPC348	4	6	21760	498	21766	498	21760	453	E315477	498	
LPC426	5	6	21761	585	21767	585	21761	532	E315478	585	
LPC428	5	6	21761	585	21767	585	21761	532	E315478	585	

LPC Series

USER MANUAL

SPX COOLING TECHNOLOGIES, INC.

827 WEST PROGRESS DRIVE
DIXON, IL 61021 USA
815 284 2700 | spxcooling@spx.com
spxcooling.com

E318714 R0 | ISSUED 02/2020
© 2020 SPX COOLING TECHNOLOGIES, INC | ALL RIGHTS RESERVED
In the interest of technological progress, all products are subject to design and/or material change without notice.

