

STC Series twin unit cooler

INSTALLATION - OPERATION - MAINTENANCE

E329630 ISSUED 02/2020

READ AND UNDERSTAND THIS MANUAL PRIOR TO OPERATING OR SERVICING THIS PRODUCT.

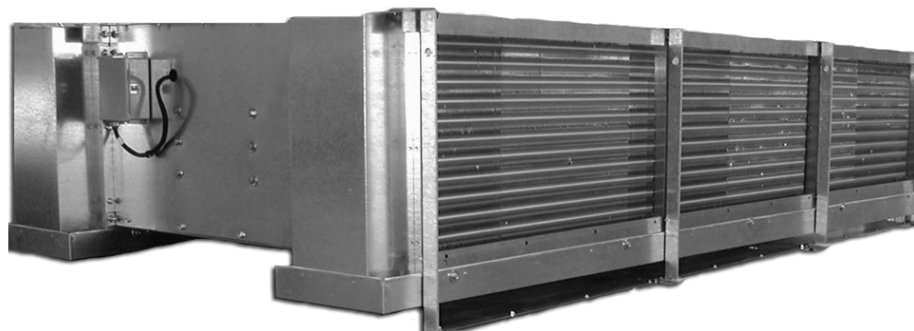

contents

1	Receipt Of Equipment	3
1.1	Inspection	3
1.2	Loss of Gas Holding Charge	3
2	Assembly of Components	3
2.1	Shipped Loose Parts	3
2.2	Dielectric Flange Union	3
2.3	Refrigerant Distributor Nozzle	3
2.4	Expansion Valve (optional item)	3
3	Rigging Instructions	3
4	Unit Location and Mounting	3
4.1	Unit Location	3
4.2	Mounting	3
5	Refrigerant Warning	6
6	Piping Installation	6
6.1	Drain Line	6
6.2	Refrigeration Piping	7
6.3	Hot Gas Interpiping	8
6.4	Evacuation and Leak Test	8
6.5	DXA And Suction Accumulators	8
7	Electrical	9
7.1	Field Wiring	9
7.2	Electrical Data	9
7.3	Suggested No Defrost Requirement Sequence of Operation	17
7.4	Suggested Air Defrost Sequence of Operation	17
7.5	Suggested Electric Defrost Sequence of Operation	17
7.6	Suggested Hot Gas Defrost Sequence of Operation	17
8	Operation	18
8.1	Pre-Startup	18
8.2	Operation Checkout	18
9	Maintenance	19
9.1	Drain Pan	19
9.2	Coil and Cabinet	19
9.3	Fan Guard Replacement	19
9.4	Fan Replacement	19
9.5	Motor Replacement	19
9.6	Electric Defrost Heaters	19
10	Replacement Parts List	20
11	Maintenance Data	21

receiving and installation

1 RECEIPT OF EQUIPMENT

1.1 INSPECTION

All equipment should be carefully checked for damage or shortages as soon as it is received. Each shipment should be carefully checked against the bill of lading. If any damage or shortage is evident, a notation must be made on the delivery receipt before it is signed and a claim should then be filed against the freight carrier. Inspection and claims are the responsibility of the recipient.

1.2 LOSS OF GAS HOLDING CHARGE

Each copper, steel, and stainless steel tube STC unit is leak tested, evacuated to remove moisture and then shipped with a gas holding charge. Absence of this charge may indicate a leak has developed in transit. The system should not be charged with refrigerant until it is verified that there is no leak, or the source of the leak is located. If the unit contains aluminum tubes or flanged refrigerant connections, the unit is leak tested and evacuated but a gas holding charge is not provided.

2 ASSEMBLY OF COMPONENTS

2.1 SHIPPED LOOSE PARTS

Dielectric Flange Union with required bolts, nuts, and gaskets (if the coil contains aluminum tubes); TEV supply shipped loose.

2.2 DIELECTRIC FLANGE UNION

Aluminum tube evaporators have aluminum flanged refrigerant connections. A dielectric flange union to attach steel pipe to the aluminum evaporator flange is provided in a separate box. The box should contain dielectric bolt gaskets, bolts, nuts, flange gasket, and mating steel socket weld flange. To avoid material damage during assembly, preweld a length of refrigerant pipe to the steel flange before assembly to the aluminum flange. See Section 6.2 for the aluminum to steel flange assembly drawing .

2.3 REFRIGERANT DISTRIBUTOR NOZZLE

For a direct expansion system, the STC Series units already have the distributor nozzle installed. As a check, see that the nozzle is in the distributor, or the auxiliary hot gas tee for direct expansion halocarbon with hot gas defrosts, before installing the thermal expansion valve to the distributor or auxiliary hot gas tee.

2.4 EXPANSION VALVE (Optional Item)

Before hanging a unit with a direct expansion design, install the expansion valve and connect the equalizer tube. The expansion valve should be installed directly to the distributor body or as close as possible with no elbows or bends. Steel expansion valves for ammonia requires the removal of the discharge tube. Locate the expansion valve bulb on a horizontal length of suction line closer to the connection stub. Position the bulb in a 3, 4, 8, or 9 o'clock

position. Do not position the bulb on the top or the bottom of the pipe. Clamp the bulb down flush and tight against the pipe and insulate. Never locate the bulb on a trap or downstream from a trap.

Expansion valves are NOT adjusted at the factory prior to shipment. It is important that the operation of the expansion valve be checked after the system has balanced out at the desired room temperature. If the coil is being starved it is necessary to reduce the superheat setting of the valve by turning the adjusting stem counter-clockwise. If the superheat is too low it is necessary to increase the superheat setting of the valve by turning the adjusting stem clockwise. It is recommended that for a 10°F to 12°F T.D. system, the valve be adjusted to maintain 5°F to 6°F of superheat.

3 RIGGING INSTRUCTIONS

An STC unit tends to be a long and heavy object with two coils. Jobsite requirements will affect the method of moving and lifting the unit into place. Carefully consider the support that is required to lift and move the unit. To ensure that the unit is not bowed or damaged when being lifted into place from above, all leg or hanger points should be used. If the unit is being lifted into place from underneath, a level support directly under all of the shipping legs is required to adequately steady the unit as it is lifted to the hanger rods..

4 UNIT LOCATION AND MOUNTING

4.1 UNIT LOCATION

Unit must be located to provide good air circulation to all areas. Space around the unit should allow for free airflow into and out of the unit. Light fixtures, shelving, ceiling structures, and product boxes must be located so that they do not block the air discharge from the unit.

On all units a space should be provided for the possible future replacement of the electric defrost heaters if heaters have been furnished. Table 1 specifies the recommended access dimensions that are needed to remove the heater rods on one or both ends of the unit.

4.2 MOUNTING

The STC units are ceiling hung or floor mounted (12" legs). Ceiling hung units should be suspended with 1/2" diameter threaded STEEL hanger rods. Do not use nylon-threaded rods. Rods should have double nuts on the top and bottom. Adequate support must be provided to hold the weight of the unit. Refer to the unit drawing supplied with the unit or the catalog for the approximate unit weight and hanger locations. All hanger holes on the coil support angle should be used to support the unit. Do not temporarily support a



receiving and installation

unit using less than all hanger or shipping leg holes. The shipping support legs can be removed after the unit is hung. See unit drawing for mounting hole locations. If the refrigeration system is direct expansion, the distributor orifice and expansion valve should be in

place before the unit is hung. See Sections 2.3 and 2.4.

The unit must be level in all directions to insure proper drainage of the condensate drain pan.

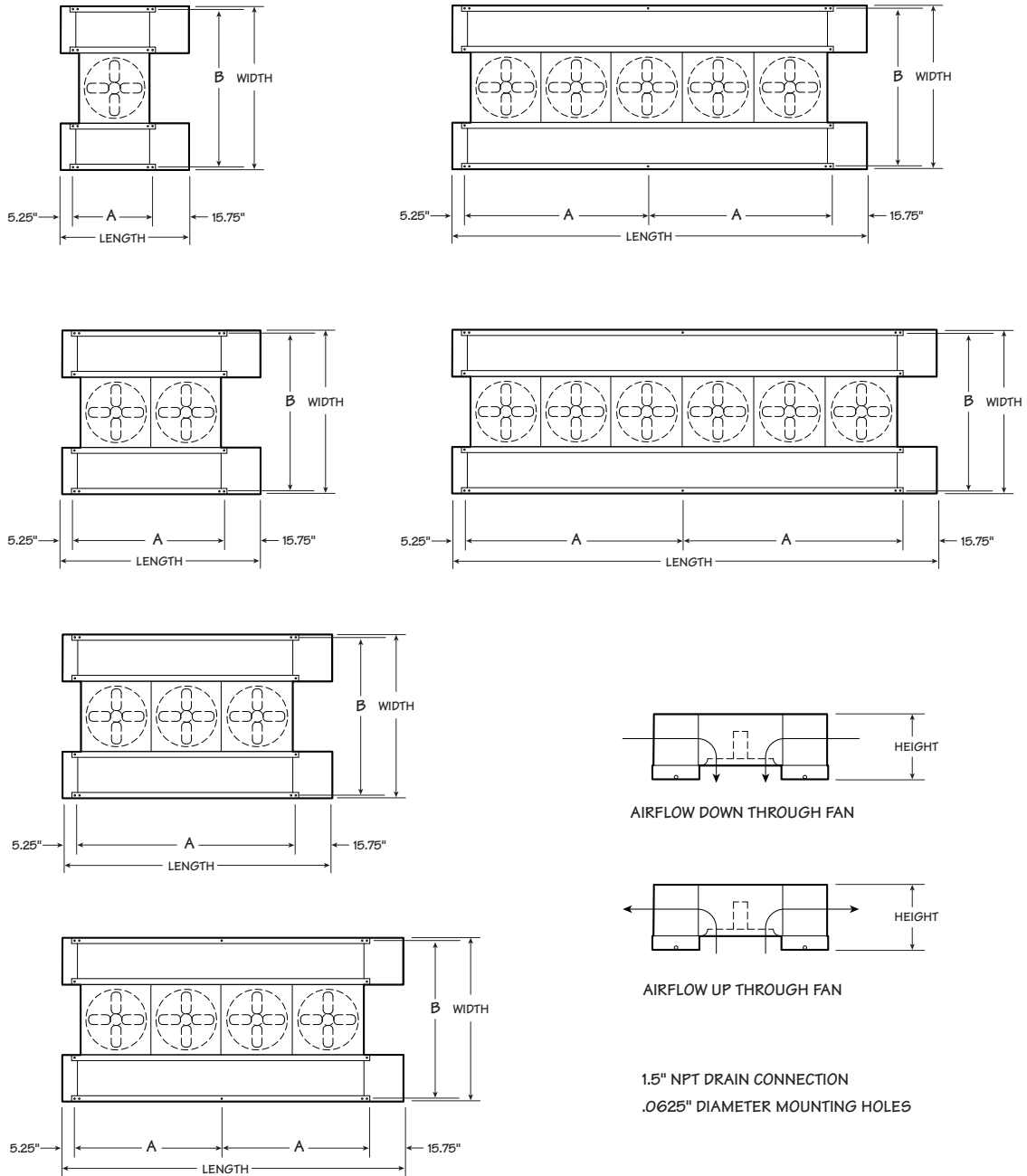

FIGURE 1 Unit Dimension

installation

Table 1 – Unit Dimensions										
Model			Dimensions in					Heater Removal Clearance in		
Fan Quantity	Fan Diameter	Rows	Length	Width	Height	A	B	Header End	Return End	
One	24"	4	55.00	56.00	24.00	34.00	51.75	38		
		6	55.00	64.00	24.00	34.00	59.75			
		8	55.00	70.00	24.00	34.00	65.75			
	30"	4	61.00	62.00	28.00	40.00	57.75	48		
		6	61.00	70.00	28.00	40.00	65.75			
		8	61.00	76.00	28.00	40.00	71.75			
Two	24"	4	85.00	56.00	24.00	64.00	51.75	68		
		6	85.00	64.00	24.00	64.00	59.75			
		8	85.00	70.00	24.00	64.00	65.75			
	30"	4	97.00	62.00	28.00	76.00	57.75	80		
		6	97.00	70.00	28.00	76.00	65.75			
		8	97.00	76.00	28.00	76.00	71.75			
Three	24"	4	115.00	56.00	24.00	94.00	51.75	98		
		6	115.00	64.00	24.00	94.00	59.75			
		8	115.00	70.00	24.00	94.00	65.75			
	30"	4	133.00	62.00	28.00	112.00	57.75	68	68	
		6	133.00	70.00	28.00	112.00	65.75			
		8	133.00	76.00	28.00	112.00	71.75			
Four	24"	4	145.00	56.00	24.00	62.00	51.75	68	68	
		6	145.00	64.00	24.00	62.00	59.75			
		8	145.00	70.00	24.00	62.00	65.75			
	30"	4	169.00	62.00	28.00	74.00	57.75	80		80
		6	169.00	70.00	28.00	74.00	65.75			
		8	169.00	76.00	28.00	74.00	71.75			
Five	24"	4	175.00	56.00	24.00	77.00	51.75	80	80	
		6	175.00	64.00	24.00	77.00	59.75			
		8	175.00	70.00	24.00	77.00	65.75			
	30"	4	205.00	62.00	28.00	92.00	57.75	98		98
		6	205.00	70.00	28.00	92.00	65.75			
		8	205.00	76.00	28.00	92.00	71.75			
Six	24"	4	205.00	56.00	24.00	92.00	51.75	98	98	
		6	205.00	64.00	24.00	92.00	59.75			
		8	205.00	70.00	24.00	92.00	65.75			
	30"	4	241.00	62.00	28.00	110.00	57.75			
		6	241.00	70.00	28.00	110.00	65.75			
		8	241.00	76.00	28.00	110.00	71.75			

installation

5 REFRIGERANT WARNING

The use of any refrigerant can be dangerous under certain conditions. Where people or product can be exposed to hazardous conditions, daily inspections should be made for the detection of any defect or malfunction that could cause the escape of the refrigerant and cause harm. In the case of halocarbon refrigerants, electronic detection devices are available for sensing the presence of such refrigerants in the atmosphere.

Ammonia is a "self-alarmed" gas with its strong odor but detection devices are strongly recommended. People and product are a concern based on the concentration levels (ppm) of ammonia along with OSHA and EPA regulations. An ammonia gas detection device connected to an external alarm system to warn that a leak is occurring is recommended. Refer to local codes and Fire Department for additional local regulations.

Only experienced, qualified personnel should install, operate, and maintain detection and alarm equipment.

6 PIPING INSTALLATION

6.1 DRAIN LINE

The drain line should be connected to both drain pans, and should be as short and as steeply pitched as possible with a minimum

of 1/4" drop per running foot. The drain line should be the same size, or one size larger than drain pan connections. A drain line trap should be installed to prevent warm moist air from migrating through the drain line. The trap should be located in the warmest and/or lowest section of the piping to avoid freezing and provide sufficient liquid head for flow through the trap. If the temperature surrounding the drain line is below freezing (32°F) it must be wrapped with a drain line heater and insulation. Be sure to also wrap the drain pan coupling. The drain line heater should be energized continuously, but to avoid the possibility of overheating heat tape manufacturers recommend a thermostat be installed. Be sure to follow the manufacturer's recommendations. The drain line trap should be outside of the freezing space. See Figure 2.

A union at the drain pan connection is recommended for future servicing. The union should be located outside the edge of the drain pan so that when the pan is lowered for cleaning or repair the drain line run is not in the way. Use two wrenches when tightening to prevent the drain fitting from twisting and damaging the drain pan. See Figure 3.

Long runs of drain line, i.e. more than a few feet, should be supported by hangers to avoid damage to the drain pan. For cleaning and inspecting the drain, tees with plugs are recommended instead of elbows.

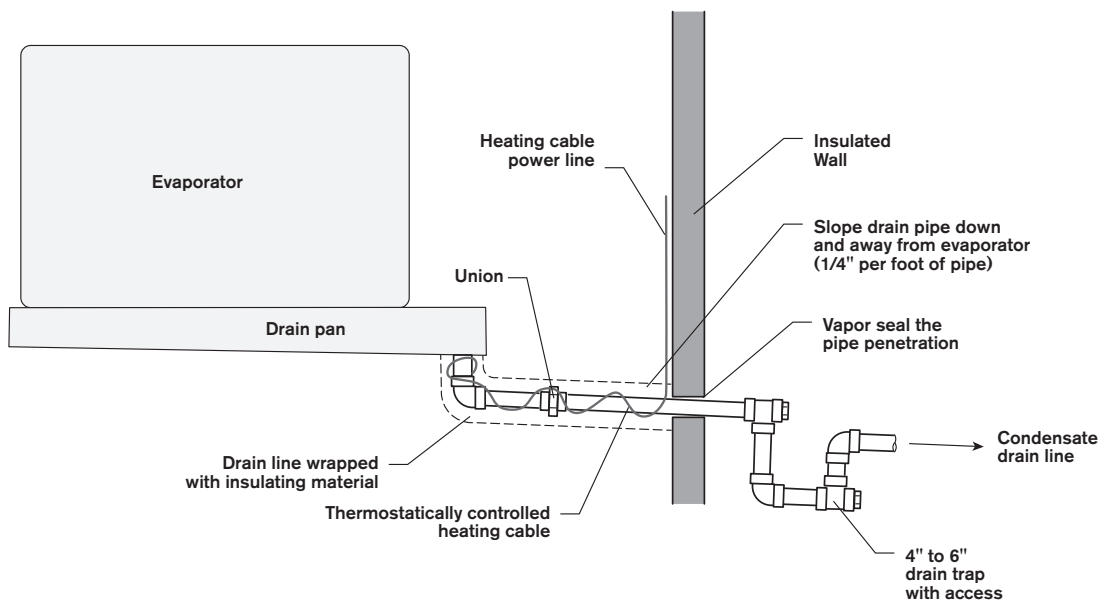

FIGURE 2 Drain Line

installation

6.2 REFRIGERATION PIPING

Installation design must conform to all local and national codes, laws and regulations applying to the site of installation. In addition, safety codes for mechanical refrigeration, IIR-2, ANSI/ASHRAE Std. 15, and ASME B31.5, should be followed as a guide to safe installation and operation practice.

Refrigerant line sizes, piping support, and piping techniques should be obtained from published recognized refrigeration standards. Under no circumstances should the refrigerant connection size of the unit be used as the basis for sizing the lines.

For aluminum flange connections see Figure 4 for final assembly drawing.

IMPORTANT—The STC units have not been designed to carry the weight of any external piping or valves. Improper support of external piping and valves may result in unit breakage and refrigerant leakage.

The horizontal suction line should slope away from the unit. Vertical suction risers on halocarbon systems require a properly sized “P” trap at the foot of the riser for proper oil return, and thermostatic expansion valve operation.

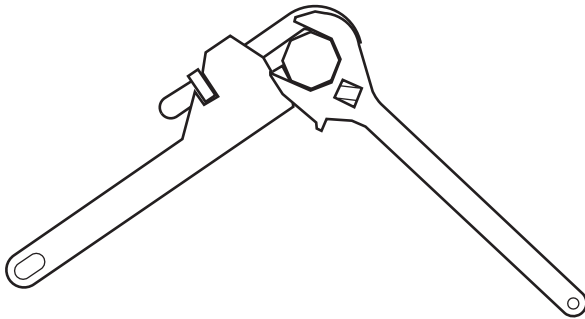

FIGURE 3 Pipe Joining

installation

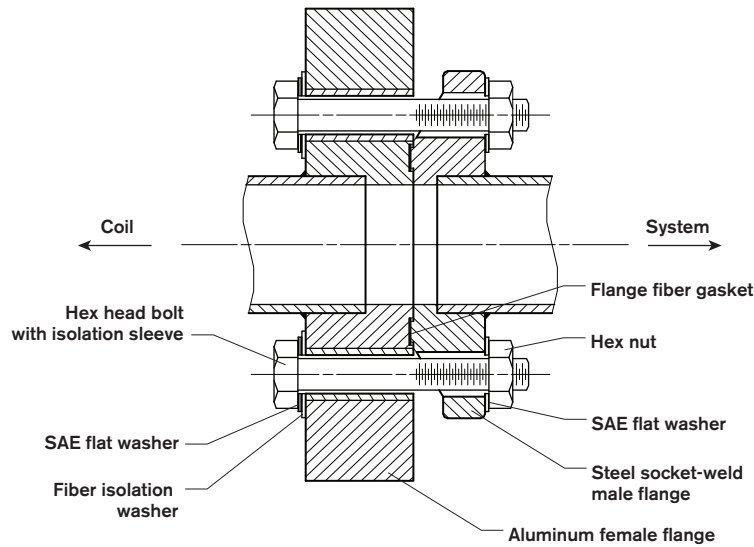

FIGURE 4 Aluminum Flange Assembly

6.3 HOT GAS INTERPIPING

If the unit was ordered with hot gas defrost the drawing shipped with the unit will contain the piping connection locations for the hot gas inlet and the condensate relief.

6.4 EVACUATION AND LEAK TEST

When all refrigeration connections have been completed, the entire system must be tested for leaks and then evacuated.

6.5 DXA AND SUCTION ACCUMULATORS

Do not use units with Direct Expansion Ammonia (DXA) feed below 0°F evaporating temperatures unless the compressor system is designed and protected to handle the overfed liquid by use of a suction accumulator.

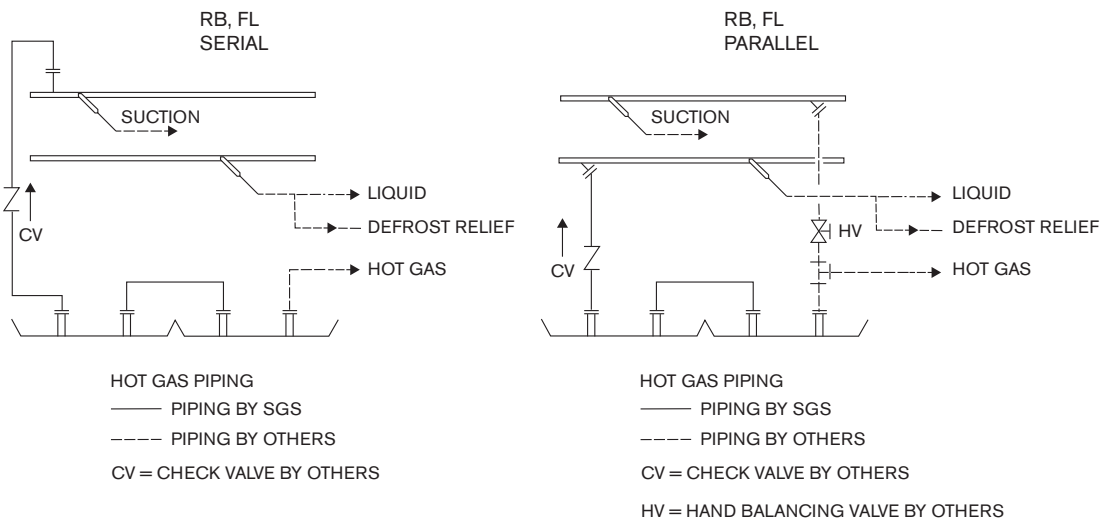

FIGURE 5 Hot Gas Interpiping

installation

7 ELECTRICAL

FOR SAFETY BEFORE SERVICING:

If the STC Series unit is equipped with an electrical power disconnect switch make sure the switch is in the "OFF" position before working on the unit, preferably locked out in this position.

7.1 FIELD WIRING

Field wiring should comply with NEC and local codes. The power supply voltage, phase and frequency must match what is shown on the unit data plate. Wire each motor so that the fan rotation is counter-clockwise.

Wiring for a unit with Air or Hot Gas Defrost requires power to the fan motors terminal block only. The fan motor terminal block is located on the end panel at the unit end opposite the refrigerant connection end of the unit. If the unit is supplied with Electric Defrost, wiring will be required to the mounted terminal blocks in the electrical enclosure for defrost heaters. See Figure 6, 7, and 8 for typical unit wiring. See wiring diagram supplied with unit for the specific wiring of each unit.

7.2 ELECTRICAL DATA

Table 1 – Motor Electrical Data													
Number of Fans	Fan RPM	hp	Fan Motor Nameplate Total Full Load Amps				Number of Fans	Fan RPM	hp	Fan Motor Nameplate Total Full Load Amps			
			230/60/3	380/50/3	460/60/3	575/60/3				230/60/3	380/50/3	460/60/3	575/60/3
One	1140	1/3	1.8	0.9	0.9	-	Four	1140	1/3	7.2	3.6	3.6	-
	1140	1/2	2.4	1.2	1.2	1.0		1140	1/2	9.6	4.8	4.8	4.0
	850	1/2	2.6	1.3	1.3	1.3		850	1/2	10.4	5.2	5.2	5.2
	1140	3/4	2.8	1.4	1.4	1.2		1140	3/4	11.2	5.6	5.6	4.8
	850	3/4	4.0	2.0	2.0	1.6		850	3/4	16.0	8.0	8.0	6.4
	1140	1	3.6	1.8	1.8	1.5		1140	1	14.4	7.2	7.2	6.0
	850	1	4.2	2.1	2.1	1.8		850	1	16.8	8.4	8.4	7.2
	1140	1-1/2	5.0	2.5	2.5	2.0		1140	1-1/2	20.0	10.0	10.0	8.0
	1140	1-1/2	5.0	2.5	2.5	2.0		1140	1-1/2	20.0	10.0	10.0	8.0
	850	1-1/2	6.2	3.1	3.1	2.5		850	1-1/2	24.8	12.4	12.4	10.0
1140	2	7.0	3.5	3.5	2.5	1140	2	28.0	14.0	14.0	10.0		
Two	1140	1/3	3.6	1.8	1.8		Five	1140	1/3	9.0	4.5	4.5	
	1140	1/2	4.8	2.4	2.4	2.0		1140	1/2	12.0	6.0	6.0	5.0
	850	1/2	5.2	2.6	2.6	2.6		850	1/2	13.0	6.5	6.5	6.5
	1140	3/4	5.6	2.8	2.8	2.4		1140	3/4	14.0	7.0	7.0	6.0
	850	3/4	8.0	4.0	4.0	3.2		850	3/4	20.0	10.0	10.0	8.0
	1140	1	7.2	3.6	3.6	3.0		1140	1	18.0	9.0	9.0	7.5
	850	1	8.4	4.2	4.2	3.6		850	1	21.0	10.5	10.5	9.0
	1140	1-1/2	10.0	5.0	5.0	4.0		1140	1-1/2	25.0	12.5	12.5	10.0
	1140	1-1/2	10.0	5.0	5.0	4.0		1140	1-1/2	25.0	12.5	12.5	10.0
	850	1-1/2	12.4	6.2	6.2	5.0		850	1-1/2	31.0	15.5	15.5	12.5
1140	2	14.0	7.0	7.0	5.0	1140	2	35.0	17.5	17.5	12.5		
Three	1140	1/3	5.4	2.7	2.7		Six	1140	1/3	10.8	5.4	5.4	
	1140	1/2	7.2	3.6	3.6	3.0		1140	1/2	14.4	7.2	7.2	6.0
	850	1/2	7.8	3.9	3.9	3.9		850	1/2	15.6	7.8	7.8	7.8
	1140	3/4	8.4	4.2	4.2	3.6		1140	3/4	16.8	8.4	8.4	7.2
	850	3/4	12.0	6.0	6.0	4.8		850	3/4	24.0	12.0	12.0	9.6
	1140	1	10.8	5.4	5.4	4.5		1140	1	21.6	10.8	10.8	9.0
	850	1	12.6	6.3	6.3	5.4		850	1	25.2	12.6	12.6	10.8
	1140	1-1/2	15.0	7.5	7.5	6.0		1140	1-1/2	30.0	15.0	15.0	12.0
	1140	1-1/2	15.0	7.5	7.5	6.0		1140	1-1/2	30.0	15.0	15.0	12.0
	850	1-1/2	18.6	9.3	9.3	7.5		850	1-1/2	37.2	18.6	18.6	15.0
1140	2	21.0	10.5	10.5	7.5	1140	2	42.0	21.0	21.0	15.0		

installation

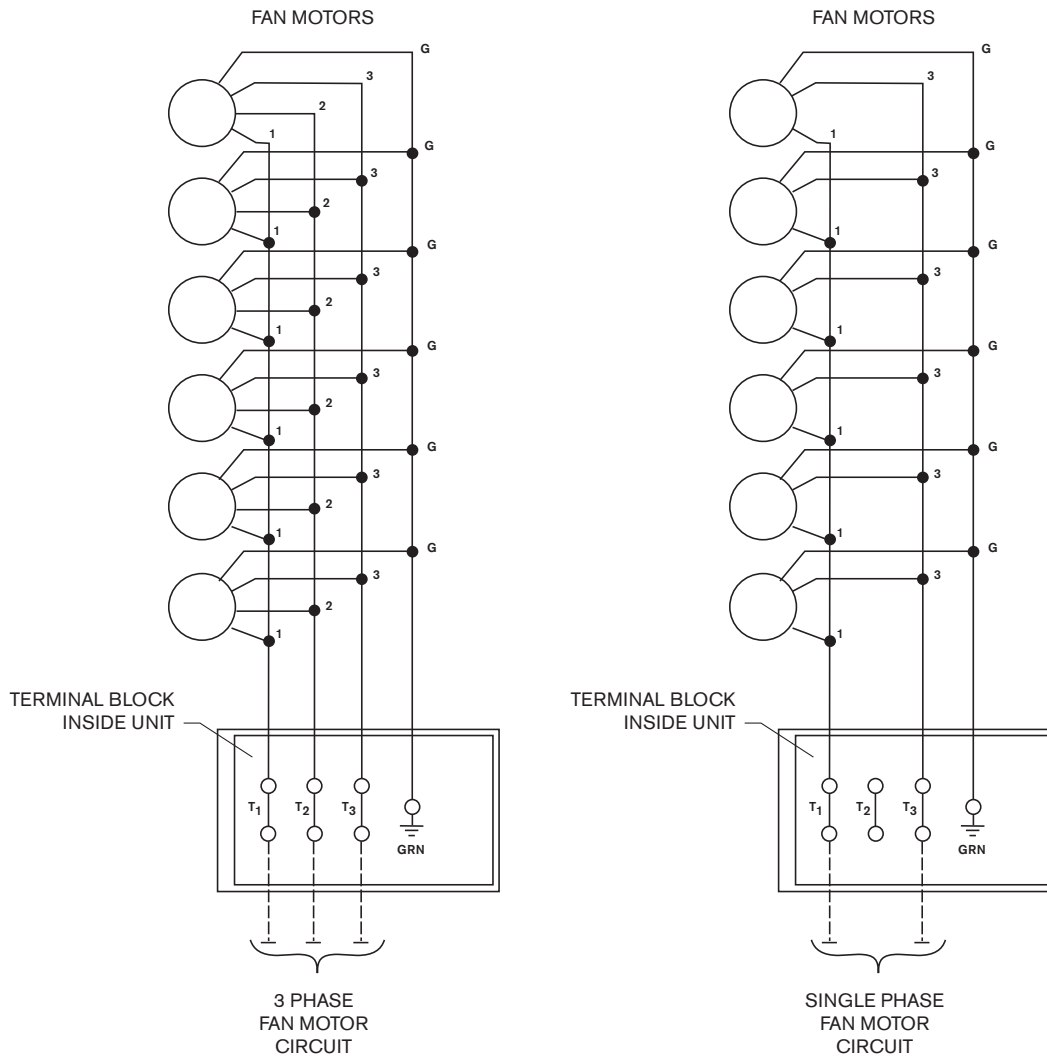

FIGURE 6 Air Defrost Wiring 230/380/460/575/3/60

installation

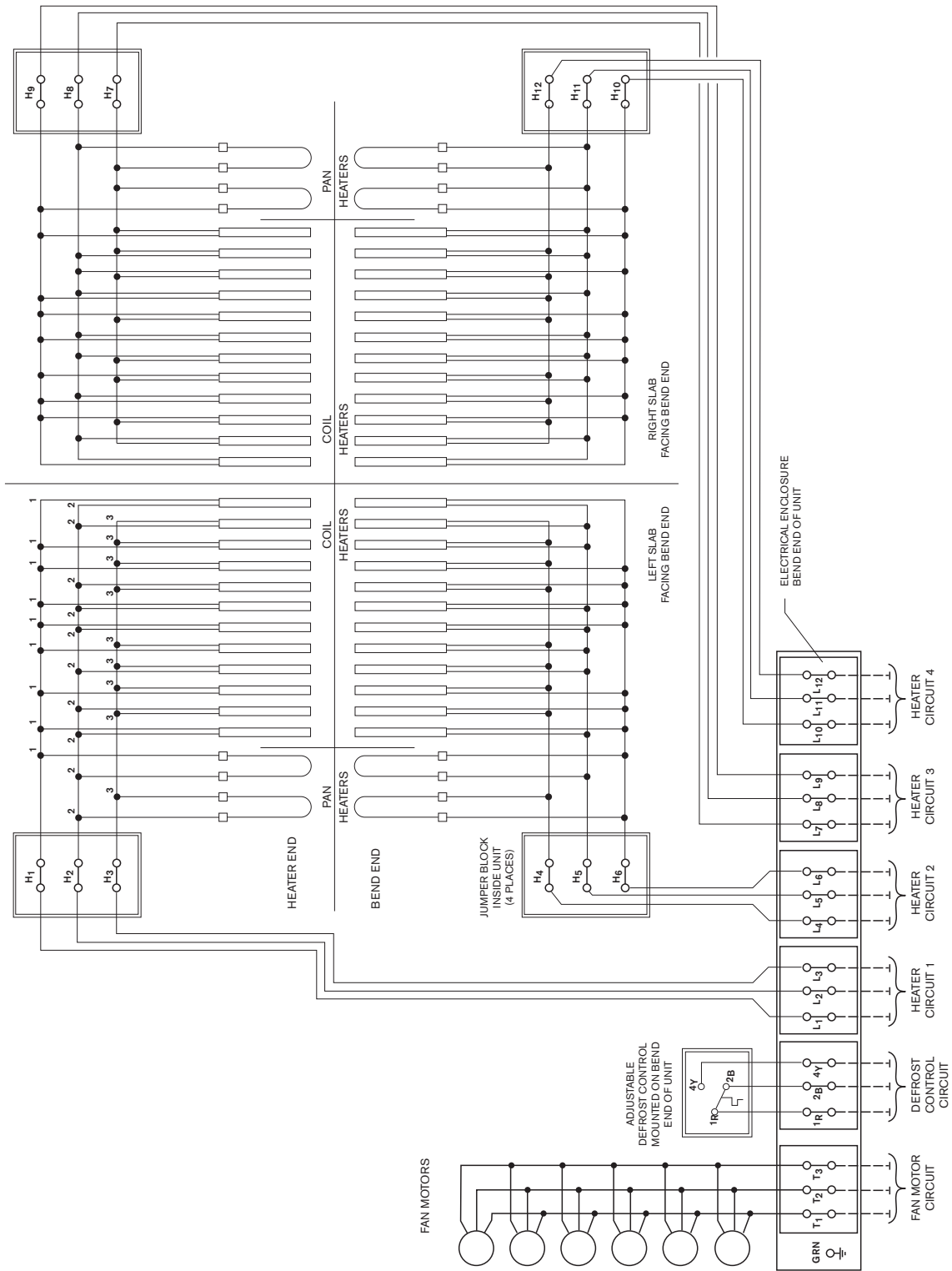

FIGURE 7 Electric Defrost Wiring 230/3/60

installation

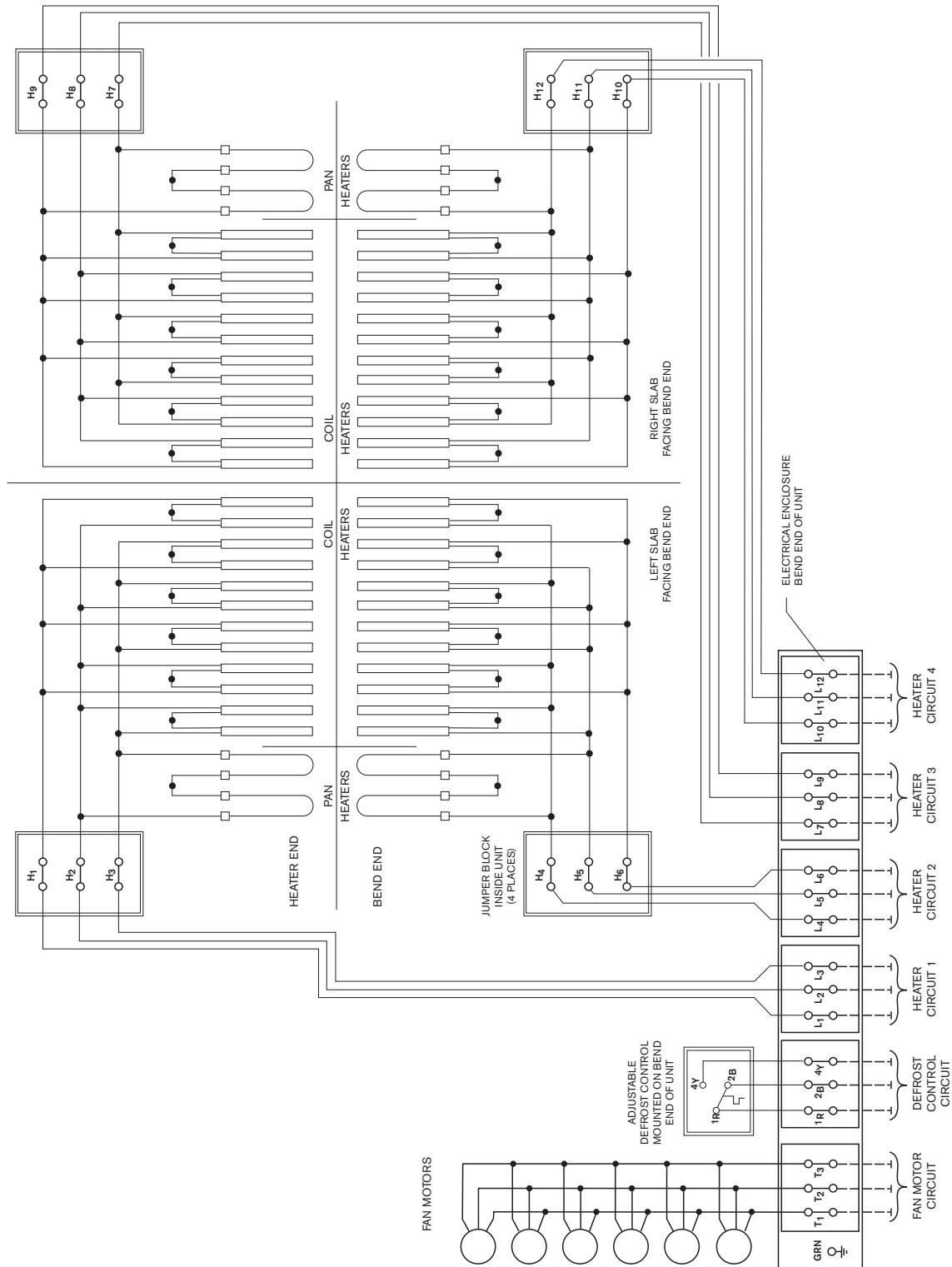

FIGURE 8 Electric Defrost Wiring 380/460/575/3/60

installation

Table 3 – 24" Fan EDL Heater Data

Model	Fan Quantity	EDL Heater Full Load Amps											
		Total kW	230V				380V		460V		575V		
			Circuit 1	Circuit 2	Circuit 3	Circuit 4	Circuit 1 (3)	Circuit 2 (4)	Circuit 1	Circuit 2	Circuit 1	Circuit 2	
STC1*-43-A, STC1*-44-A	1	5.50	14.12					8.55		7.07		5.65	
STC1*-63-A, STC1*-64-A	1	7.50	19.31					12.53		10.35		8.28	
STC1*-83-A, STC1*-84-A	1	9.50	24.95					15.41		12.73		10.19	
STC1*-46-A	1	7.50	19.31					12.53		10.35		8.28	
STC1*-66-A	1	9.50	24.95					15.41		12.73		10.19	
STC1*-86-A	1	11.50	29.18					17.67		14.59		11.67	
STC2*-43-A, STC2*-44-A	2	10.40	27.11					16.44		13.58		10.87	
STC2*-63-A, STC2*-64-A	2	14.40	36.92					23.70		19.58		15.66	
STC2*-83-A, STC2*-84-A	2	18.40	24.89	24.89				30.12		24.89		19.91	
STC2*-46-A	2	14.40	36.92					23.70		19.58		15.66	
STC2*-66-A	2	18.40	24.89	24.89				30.12		24.89		19.91	
STC2*-86-A	2	22.40	28.63	28.63				34.66		28.63		22.90	
STC3*-43-A, STC3*-44-A	3	15.20	39.91					24.23		20.01		16.01	
STC3*-63-A, STC3*-64-A	3	21.20	28.62	28.62				34.64		28.62		22.89	
STC3*-83-A, STC3*-84-A	3	27.20	36.94	36.94				44.72		36.94		29.55	
STC3*-46-A	3	21.20	28.62	28.62				34.64		28.62		22.89	
STC3*-66-A	3	27.20	36.94	36.94				44.72		36.94		29.55	
STC3*-86-A	3	33.20	42.58	42.58				27.35	27.35	42.58		34.06	
STC4*-43-A, STC4*-44-A	4	20.00	28.26	28.26				31.91		26.36		21.09	
STC4*-63-A, STC4*-64-A	4	28.00	35.79	35.79				43.32		35.79		28.63	
STC4*-83-A, STC4*-84-A	4	36.00	47.08	47.18				29.66	29.66	47.08		37.66	
STC4*-46-A	4	28.00	35.79	35.79				43.32		35.79		28.63	
STC4*-66-A	4	36.00	47.08	47.18				29.66	29.66	47.08		37.66	
STC4*-86-A	4	44.00	28.26	28.26	28.26	28.26		34.21	34.21	28.26	28.26	45.18	
STC5*-43-A, STC5*-44-A	5	25.00	35.30	35.38				39.90		32.96		26.37	
STC5*-63-A, STC5*-64-A	5	35.00	44.73	44.73				28.49	28.49	44.73		35.79	
STC5*-83-A, STC5*-84-A	5	45.00	36.27	27.30	36.27	24.98		37.04	37.04	30.59	30.59	46.34	
STC5*-46-A	5	35.00	44.73	44.73				28.49	28.49	44.73		35.79	
STC5*-66-A	5	45.00	36.27	27.30	36.27	24.98		37.04	37.04	30.59	30.59	46.34	
STC5*-86-A	5	55.00	41.93	28.72	41.93	28.72		43.88	43.88	36.25	36.25	29.00	29.00
STC6*-43-A, STC6*-44-A	6	29.80	42.11	42.11				47.63		39.35		31.48	
STC6*-63-A, STC6*-64-A	6	41.80	28.05	28.05	28.05	28.05		33.96	33.96	28.05	28.05	42.72	
STC6*-83-A, STC6*-84-A	6	53.80	36.65	39.35	36.65	36.65		44.37	44.37	36.65	36.65	29.32	29.32
STC6*-46-A	6	41.80	28.05	28.05	28.05	28.05		33.96	33.96	28.05	28.05	42.72	
STC6*-66-A	6	53.80	36.65	39.35	36.65	36.65		44.37	44.37	36.65	36.65	29.32	29.32
STC6*-86-A	6	65.80	42.30	42.30	42.30	42.30	(2) 27.35	(2) 27.35		42.30	42.30	33.84	33.84

* Aluminium and copper fin coil only

installation

Table 4 – 30" Fan EDL Heater Data

Model	Fan Quantity	EDL Heater Full Load Amps											
		Total kW	230V				380V		460V		575V		
			Circuit 1	Circuit 2	Circuit 3	Circuit 4	Circuit 1 (3)	Circuit 2 (4)	Circuit 1	Circuit 2	Circuit 1	Circuit 2	
STC1*-43-C, STC1*-44-C	1	6.50	16.76					10.15		8.39		6.71	
STC1*-63-C, STC1*-64-C	1	8.90	22.89					14.81		12.24		9.79	
STC1*-83-C, STC1*-84-C	1	11.30	29.65					18.38		15.18		12.15	
STC1*-46-C	1	8.90	22.89					14.81		12.24		9.79	
STC1*-66-C	1	13.70	34.83					21.09		17.42		13.94	
STC1*-86-C	1	16.10	40.96					25.75		21.27		17.02	
STC2*-43-C, STC2*-44-C	2	12.40	32.38					19.64		16.23		12.98	
STC2*-63-C, STC2*-64-C	2	17.20	44.08					28.26		23.35		18.68	
STC2*-83-C, STC2*-84-C	2	22.00	29.78	29.78				36.06		29.78		23.83	
STC2*-46-C	2	17.20	44.08					28.26		23.35		18.68	
STC2*-66-C	2	26.80	34.28	34.28				41.50		34.28		27.43	
STC2*-86-C	2	31.60	41.42	41.42				25.14	25.14	41.42		33.13	
STC3*-43-C, STC3*-44-C	3	18.20	47.35					28.99		23.95		19.16	
STC3*-63-C, STC3*-64-C	3	25.40	32.49	32.49				39.33		32.49		25.99	
STC3*-83-C, STC3*-84-C	3	32.60	42.00	43.83				26.78	26.78	42.00		33.60	
STC3*-46-C	3	25.40	32.49	32.49				39.33		32.49		25.99	
STC3*-66-C	3	39.80	31.45	17.61	31.45	17.61		32.25	32.25	26.64	26.64	40.83	
STC3*-86-C	3	47.00	39.72	21.65	39.72	21.65		37.15	37.15	30.69	30.69	47.68	
STC4*-43-C, STC4*-44-C	4	24.00	33.91	33.91				38.29		31.63		25.30	
STC4*-63-C, STC4*-64-C	4	33.60	42.94	42.94				27.35	27.35	42.94		34.36	
STC4*-83-C, STC4*-84-C	4	43.20	29.40	31.63	29.40	31.63		35.59	35.59	29.40	29.40	45.20	
STC4*-46-C	4	33.60	42.94	42.94				27.35	27.35	42.94		34.36	
STC4*-66-C	4	52.80	33.91	33.91	33.91	33.91		41.05	41.05	33.91	33.91	27.13	27.13
STC4*-86-C	4	62.40	40.67	40.67	40.67	40.67		(2) 24.7	(2) 24.7	40.67	40.67	32.53	32.53
STC5*-43-C, STC5*-44-C	5	29.80	42.11	42.11				47.63		39.35		31.48	
STC5*-63-C, STC5*-64-C	5	41.80	28.05	28.05	28.05	28.05		33.96	33.96	28.05	28.05	42.72	
STC5*-83-C, STC5*-84-C	5	53.80	36.65	36.65	36.65	36.65		44.37	44.37	36.65	36.65	29.32	29.32
STC5*-46-C	5	41.80	28.05	28.05	28.05	28.05		33.96	33.96	28.05	28.05	42.72	
STC5*-66-C	5	65.80	42.30	42.30	42.30	42.30		(2) 27.35	(2) 27.35	42.30	42.30	33.84	33.84
STC5*-86-C	5	77.80						(2) 30.71	(2) 30.71	(2) 25.37	(2) 25.37	40.51	40.51

* Aluminium and copper fin coil only

installation

Table 5 – 24" Fan ED Heater Data

Model	Fan Quantity	ED Heater Full Load Amps											
		Total kW	230V				380V		460V		575V		
			Circuit 1	Circuit 2	Circuit 3	Circuit 4	Circuit 1	Circuit 2	Circuit 1	Circuit 2	Circuit 1	Circuit 2	
STC1*-43-A, STC1*-44-A	1	4.00	11.30					6.96		5.75		4.60	
STC1*-63-A, STC1*-64-A	1	4.00	11.30					6.96		5.75		4.60	
STC1*-83-A, STC1*-84-A	1	6.00	15.06					9.12		7.53		6.02	
STC1*-46-A	1	4.00	11.30					6.96		5.75		4.60	
STC1*-66-A	1	6.00	15.06					9.12		7.53		6.02	
STC1*-86-A	1	8.00	20.74					13.67		11.30		9.04	
STC2*-43-A, STC2*-44-A	2	8.00	22.59					13.93		11.50		9.20	
STC2*-63-A, STC2*-64-A	2	8.00	22.59					13.93		11.50		9.20	
STC2*-83-A, STC2*-84-A	2	12.00	30.12					18.23		15.06		12.05	
STC2*-46-A	2	8.00	22.59					13.93		11.50		9.20	
STC2*-66-A	2	12.00	30.12					18.23		15.06		12.05	
STC2*-86-A	2	16.00	41.48					27.35		22.59		18.07	
STC3*-43-A, STC3*-44-A	3	12.00	33.89					20.89		17.25		13.80	
STC3*-63-A, STC3*-64-A	3	12.00	33.89					20.89		17.25		13.80	
STC3*-83-A, STC3*-84-A	3	18.00	45.18					27.35		22.59		18.07	
STC3*-46-A	3	12.00	33.89					20.89		17.25		13.80	
STC3*-66-A	3	18.00	45.18					27.35		22.59		18.07	
STC3*-86-A	3	24.00	33.89	33.89				41.02		33.89		27.11	
STC4*-43-A, STC4*-44-A	4	16.00	41.48					27.35		22.59		18.07	
STC4*-63-A, STC4*-64-A	4	16.00	41.48					27.35		22.59		18.07	
STC4*-83-A, STC4*-84-A	4	24.00	30.12	30.12				36.46		30.12		24.10	
STC4*-46-A	4	16.00	41.48					27.35		22.59		18.07	
STC4*-66-A	4	24.00	30.12	30.12				36.46		30.12		24.10	
STC4*-86-A	4	32.00	41.48	41.48				27.35	27.35	41.48		33.18	
STC5*-43-A, STC5*-44-A	5	20.00	28.26	28.26				34.21		28.26		22.61	
STC5*-63-A, STC5*-64-A	5	20.00	28.26	28.26				34.21		28.26		22.61	
STC5*-83-A, STC5*-84-A	5	30.00	37.65	37.65				45.58		37.65		30.12	
STC5*-46-A	5	20.00	28.26	28.26				34.21		28.26		22.61	
STC5*-66-A	5	30.00	37.65	37.65				45.58		37.65		30.12	
STC5*-86-A	5	40.00	33.89	22.59	33.89	22.59		34.21	34.21	28.26	28.26	42.21	
STC6*-43-A, STC6*-44-A	6	24.00	33.89	33.89				41.02		33.89		27.11	
STC6*-63-A, STC6*-64-A	6	24.00	33.89	33.89				41.02		33.89		27.11	
STC6*-83-A, STC6*-84-A	6	36.00	45.18	45.18				27.35	27.35	45.18		36.15	
STC6*-46-A	6	24.00	33.89	33.89				41.02		33.89		27.11	
STC6*-66-A	6	36.00	45.18	45.18				27.35	27.35	45.18		36.15	
STC6*-86-A	6	48.00	33.89	33.89	33.89	33.89		41.02	41.02	33.89	33.89	27.11	27.11

* Aluminium and copper fin coil only

installation

Table 6 – 30" Fan ED Heater Data

Model	Fan Quantity	ED Heater Full Load Amps											
		Total kW	230V				380V		460V		575V		
			Circuit 1	Circuit 2	Circuit 3	Circuit 4	Circuit 1 (3)	Circuit 2 (4)	Circuit 1	Circuit 2	Circuit 1	Circuit 2	
STC1*-43-C, STC1*-44-C	1	4.80	13.56					8.36		6.90		5.52	
STC1*-63-C, STC1*-64-C	1	7.20	18.07					10.94		9.04		7.23	
STC1*-83-C, STC1*-84-C	1	9.60	24.89					16.41		13.56		10.84	
STC1*-46-C	1	7.20	18.07					10.94		9.04		7.23	
STC1*-66-C	1	9.60	24.89					16.41		13.56		10.84	
STC1*-86-C	1	12.00	31.63					19.21		15.87		12.69	
STC2*-43-C, STC2*-44-C	2	9.60	27.11					16.71		13.80		11.04	
STC2*-63-C, STC2*-64-C	2	14.40	36.15					21.88		18.07		14.46	
STC2*-83-C, STC2*-84-C	2	19.20	27.11	27.11				32.82		27.11		21.69	
STC2*-46-C	2	14.40	36.15					21.88		18.07		14.46	
STC2*-66-C	2	19.20	27.11	27.11				32.82		27.11		21.69	
STC2*-86-C	2	24.00	31.74	31.74				38.42		31.74		25.39	
STC3*-43-C, STC3*-44-C	3	14.40	38.43					24.66		20.37		16.30	
STC3*-63-C, STC3*-64-C	3	21.60	27.11	27.11				32.82		27.11		21.69	
STC3*-83-C, STC3*-84-C	3	28.80	38.43	38.43				46.52		38.43		30.74	
STC3*-46-C	3	21.60	27.11	27.11				32.82		27.11		21.69	
STC3*-66-C	3	28.80	38.43	38.43				46.52		38.43		30.74	
STC3*-86-C	3	36.00	47.46	47.46				30.12	30.12	47.46		37.97	
STC4*-43-C, STC4*-44-C	4	27.11	27.11			32.82		27.11	27.11			21.69	
STC4*-63-C, STC4*-64-C	4	36.15	36.15			43.76		36.15	36.15			28.92	
STC4*-83-C, STC4*-84-C	4	27.11	27.11	27.11	27.11	32.82	32.82	27.11	27.11	27.11		39.82	
STC4*-46-C	4	36.15	36.15			43.76		36.15	36.15			28.92	
STC4*-66-C	4	27.11	27.11	27.11	27.11	32.82	32.82	27.11	27.11	27.11		39.82	
STC4*-86-C	4	31.74	31.74	31.74	31.74	38.42	38.42	31.74	31.74	31.74		25.39	25.39
STC5*-43-C, STC5*-44-C	5	24.00	33.89	33.89				41.02		33.89		27.11	
STC5*-63-C, STC5*-64-C	5	36.00	45.18	45.18				27.35	27.35	45.18		36.15	
STC5*-83-C, STC5*-84-C	5	48.00	33.89	33.89	33.89	33.89	41.02	41.02	33.89	33.89		27.11	27.11
STC5*-46-C	5	36.00	45.18	45.18				27.35	27.35	45.18		36.15	
STC5*-66-C	5	48.00	33.89	33.89	33.89	33.89	41.02	41.02	33.89	33.89		27.11	27.11
STC5*-86-C	5	60.00					(2) 27.35	(2) 27.35	39.67	39.67		31.74	31.74

* Aluminium and copper fin coil only

installation

7.3 SUGGESTED NO DEFROST REQUIREMENT SEQUENCE OF OPERATION

Used for units with a suction temperature above freezing.

- A. When the room thermostat calls for cooling the liquid solenoid valve opens allowing refrigerant begins to flow to the unit.
- B. When the thermostat is satisfied the liquid solenoid valve closes, which stops refrigerant flowing to the unit.
- C. The fan motors continue to run throughout the cycle.

7.4 SUGGESTED AIR DEFROST SEQUENCE OF OPERATION

Used for units with a suction temperature below freezing, but a room temperature above 36°F.

- A. A defrost timer is wired into the fan motors control.
- B. The timer turns off the liquid line solenoid valve at a predetermined time, but the fan motors continue to operate.
- C. When the refrigerant is completely boiled out of the unit, the fan motors still continue to operate so that the room air temperature melts the coil frost.
- D. At a second predetermined time, the timer energizes the liquid solenoid valve and refrigeration resumes.

The timer settings are to be programmed per the need of each evaporator.

7.5 SUGGESTED ELECTRIC DEFROST SEQUENCE OF OPERATION

Used for units with a suction temperature below freezing. The Electric Defrost cycle is time clock initiated and temperature terminated. Three or four defrost cycles per 24 hour period are typical. The following sequence is based on the Paragon 8145 or equal time clock.

- A. Power is supplied to the defrost timer.
- B. The defrost termination thermostat is off and the defrost heaters are off.
- C. The unit operates in cooling mode.
- D. Upon initiation of the defrost cycle the time clock turns off the liquid line solenoid valve.
- E. After a site determined time period the timer de-energizes the fan motors and energizes the defrost heaters.
- F. The heaters, positioned within the coil turbo spacers in the fin pack, heat up the fins directly to melt the accumulated frost.
- G. When the coil reaches the temperature setting of the defrost termination thermostat the thermostat opens the defrost circuit to cut off power to the heaters.

- H. The defrost timer energizes the liquid line solenoid valve allowing refrigerant to flow into the unit, cooling the coil and refreezing any remaining condensate drops that are still present.

- I. The fan motor is started through the fan delay thermostat temperature setting, putting the unit in the cooling cycle.

The timer settings and the adjustable defrost termination fan delay thermostat settings are to be programmed per the need of each evaporator.

7.6 SUGGESTED HOT GAS DEFROST SEQUENCE OF OPERATION

Used for units with a suction temperature below freezing. The Hot Gas Defrost cycle is time clock initiated and terminated. The following sequence is based on the Hansen Frost Master or equal time clock.

- A. Power is supplied to the defrost timer.
- B. The unit operates in the cooling cycle.
- C. Upon initiation of the defrost cycle, the defrost time clock turns off the liquid line solenoid valve. The fan motor(s) continues to operate to boil off the remaining refrigerant in the coil tubes.
- D. After a predetermined time period the defrost timer de-energizes the fan motor(s) and energizes the hot gas supply solenoid valve. Note that larger units may also have a "soft defrost" solenoid to slowly pressurize the coil, which will open before the main hot gas supply solenoid.
- E. Hot gas flows into the unit and warms up the tubes and fins (and drain pan if an HGU unit), melting the accumulated frost.
- F. Approximately eight to twelve minutes after starting the hot gas defrost cycle the defrost time clock should de-energize the hot gas supply solenoid valve. If the unit is in defrost for a much longer period of time the condensate on the tubes and fins could "steam" and refreeze on the fan cabinet, fan(s), or venturi causing maintenance problems.
- G. The defrost time clock should energize the vent solenoid, allowing any remaining high pressure gas to escape the coil.
- H. The defrost timer energizes the liquid line and suction line solenoid valves allowing refrigerant to flow into the unit, cooling the coil and refreezing any remaining condensate drops that are still present.
- I. The fan motor is energized after a preset fan delay in the time clock and the unit is in the cooling cycle.

The timer settings are to be programmed per the need of each evaporator.

operation

8.0 OPERATION

8.1 PRE-START UP

After the installation is completed, a review of the following items should be preformed before the system is placed into operation:

- A. Check electrical connections, fan bushing set screws, motor mount bolts, coil flange bolts, drain pan flange bolts, and all other fasteners for tightness. If required, be sure the thermostatic expansion valve bulb is properly located, strapped, and insulated.
- B. For systems with a defrost time clock check the timer to see that it is set for the correct time of day and the starting pins have been installed (normally two or three sets per day). Defrost should be scheduled when the freezer doors are not likely to be open.
- C. When the unit is first started the room temperature is typically above the contact closing temperature of the fan delay thermostat, if a fan delay thermostat is provided for Electric Defrost units (see that particular units electrical diagram). The fans may remain off for a lengthy period of time. To prevent this delay it is permissible to install a temporary jumper wire between terminals "1R" and "2B". Once the room temperature is below 25°F the jumper wire should be removed.
- D. The motors for STC units are greased from the motor manufacturer.

8.2 OPERATION CHECKOUT

With the system operating, check the supply voltage. The voltage must be within +/- 10% of the voltage marked on the unit nameplate and the phase to phase unbalance should be 2% or less.

LISTEN CAREFULLY to the unit to make sure there are no unusual sounds. Sounds such as a noisy motor, the fan(s) scraping on the housing, or loose fasteners allowing parts to rattle need to be addressed immediately before continued unit operation.

Check the room THERMOSTAT setting. Be sure it functions properly.

For RECIRCULATED refrigeration systems the hand expansion valve should be opened slowly until either condensate or frost forms on the return bends from the bottom to the top of the coil. A good indicator is when the defrost relief valve reads 5 PSI above suction pressure.

For FLOODED refrigeration systems check to make sure the float valve is working properly and allows refrigerant into the drum to the appropriate level when the level is sufficiently low. If a hand expansion valve has been added, the valve should be set to allow liquid make up 70% of the time.

For DIRECT EXPANSION systems let the system balance out at the desired room temperature and check the operation of the expansion valve by properly measuring the superheat at the sensing bulb. As much as thirty minutes may be required for the new balance to take place after an adjustment is made.

For BRINE or WATER COOLING systems keep the closest vent to the coil open while the fluid fills the coil to allow trapped air to escape. Close the vent valve once fluid flows out of the valve and check for water hammer in the coil.

With HOT GAS DEFROST systems allow the coil to frost, then manually advance the defrost timer to initiate a defrost cycle. Observe the defrost cycle to see if all controls are functioning properly and that the coil is clear of all frost before the system returns to refrigeration. Adjust the time clock pins if necessary. Reset the defrost timer to the correct time of day. A defrost cycle is only needed when the frost build up is such that it impedes the airflow through the coil. The defrost requirements will vary on each installation and may change depending on the time of the year and other conditions.

With ELECTRIC DEFROST systems allow the coil to frost then manually advance the defrost timer to initiate a defrost cycle. Observe the defrost cycle to see if all controls are functioning properly and that the coil is clear of all frost before the system returns to refrigeration. Adjust the time clock pins if necessary. Reset the defrost timer to the correct time of day. A defrost cycle is only needed when the frost build up is such that it impedes the airflow through the coil. The defrost requirements will vary on each installation and may change depending on the time of the year and other conditions.

maintenance

9 MAINTENANCE

A preventive maintenance schedule should be established as soon as the STC Series unit is installed. The unit should be inspected periodically for proper operation and build up of frost and debris.

WARNING: All power to the evaporator must be off before cleaning or performing maintenance.

9.1 DRAIN PAN

Inspect and clean each drain pan to insure free drainage of condensate. Drain pans should be cleaned regularly with warm water and soap.

If a drain pan needs to be removed, support the long dimension of the pan from underneath with a minimum of two 4x4s for one thru four fan units, or two 6x6s for five and six fan units, so the outer sheet metal skin does not buckle and become damaged. Do not point load the center of the support beam. For longer pans more than one lifting device may be needed to keep the pan balanced when lifting. If the drain pan uses hot gas defrost make sure the coil is completely pumped out and isolated with hand valves to prevent refrigerant from escaping to the atmosphere. Remove the hot gas piping or electric wires if the unit has a HTS or an electric defrost drain pan. Remove the drain line so that it is out of the way of the pan when it is being lowered. Remove the drain pan attachment bolts from the bottom of the evaporator unit and slowly lower the pan from the unit. Assemble pan in reverse order. Replace hot gas interpiping gaskets before tightening flange bolts.

9.2 COIL AND CABINET

Clean coils, the fan cabinet, fan(s), and fan guard(s) with warm water and soap. A low pressure water hose is recommended to avoid water entering into electrical components and causing equipment failure.

The evaporator coil should be checked once a month for proper defrosting. Many variables affect coil frosting such as room temperature, type of product being stored or processed, how often new product is brought in, and the length of time the door to the room remains open. Summer conditions of high humidity can cause heavier frost loads and it may be necessary to change the number of defrost cycles seasonally.

9.3 FAN GUARD REPLACEMENT

To remove a fan guard for fan-motor maintenance, or for guard replacement, make sure all electrical power to the unit has been turned off before any work is performed. While supporting the guard to the unit remove nuts. Remove the guard. Reassemble in the reverse order.

9.4 FAN REPLACEMENT

If a fan is out of balance, damaged, or needs to be replaced, the unit does not need to be at floor level for maintenance. Make sure

all electrical power to the unit has been turned off before any work is performed. Remove the fan guard as described in Section 9.3. Loosen two bolts from the bushing that hold the fan onto the motor shaft. Remove the fan. Clean and deburr the motor shaft if necessary. Place the new fan onto the motor shaft and tighten bolts. Reattach the fan guard.

9.5 MOTOR REPLACEMENT

Make sure all electrical power to the unit has been turned off before any work is performed. To replace a motor a lifting device may be required for heavy motors. Remove the fan guard and fan as described in Sections 9.3 and 9.4. Remove the motor cover and disconnect motor leads. Support the motor from the unit then unbolt from the motor mount.

Assemble the replacement motor, fan and fan guard in the reverse order.

When starting the motor make sure the fan is rotating in the proper counter clockwise direction, when looking at the fan from under the unit. If the fan rotates clockwise, stop the motor, shut off all power to the unit, and change the motor wiring for counter clockwise rotation.

9.6 ELECTRIC DEFROST HEATERS

Inspect the electric defrost heater ends to determine if they are operating. A heater will be operating properly when the heater is observed to be glowing during the defrost cycle. If a heater rod is cold during the defrost cycle it will need to be replaced.

Coil heaters require horizontal removal from ends of the unit. See Table 1 to determine if heaters have to be removed from one or both ends of the unit. Turn off all electrical power on the unit. Remove heater wires from the terminal block and note where original wires were located. Rotate the heater rod so that the heater and retainer clip can be slid through the coil endplate slot. Remove clip from the old heater rod and install on the new heater rod in approximately the same location as the original heater. Install new heater rod in the original coil slot, rotate the rod 90°, and place new wires in position of original wires in the terminal block.

Drain pan heaters require the drain pan to be removed. Support the long dimension of the pan from underneath with a minimum of two 4x4s for one thru four fan units or two 6x6s for five and six fan units so the outer sheet metal skin does not buckle and become damaged. For longer pans more than one lifting device may be needed to keep the pan balanced when lifting. Remove heater's wires from terminal blocks. Remove the drain line so that it is out of the way of the pan when it is being lowered. Remove the drain pan attachment bolts from the bottom of the evaporator unit and slowly lower the pan from the unit. Remove clips from the heater's hold down brackets and remove brackets. Replace the heater. Replace hold down brackets and assemble the pan in reverse order. Rewire heaters in original terminal blocks.

maintenance

10 REPLACEMENT PARTS LIST

Following are major replacement parts of standard STC Series units. Model Number, Serial Number, and voltage will be necessary to identify the correct replacement part.

Fan Quantity	Fan Diameter in	Fan Section in	Model Code	Air Flow Up (U) Hub on Air Entering Side Fan part number	Motor rpm	Motor hp	230/460/3/60 Motor part number	575/3/60 Motor part number	Air Flow Down (D) Hub on Air Entering Side Fan part number
1	24	30	AA	E315554	1140	1/3	E315544	E315534	E315566
1	24	30	AB	E315555	1140	1/2	E315545	E315535	E315567
1	24	30	AC	E315556	1140	3/4	E315546	E315536	E315568
1	24	30	AD	E315557	1140	1	E315547	E315537	E315569
1	24	30	AE	E315558	1140	1.5	E315548	E315538	E315570
1	30	36	CD	E315559	1140	1	E315547	E315537	E315571
1	30	36	CE	E315560	1140	1.5	E315548	E315538	E315572
1	30	36	CF	E315561	1140	2	E315549	E315539	E315573
1	30	36	BB	E315562	850	1/2	E315550	E315540	E315574
1	30	36	BC	E315563	850	3/4	E315551	E315541	E315575
1	30	36	BD	E315564	850	1	E315552	E315542	E315576
1	30	36	BE	E315565	850	1.5	E315553	E315543	E315577

Coil Heater Overall Length in	Coil Heater Rated Watts	230V Coil Heater for 230/460V Power part number	190V Coil Heater for 380V Power part number	288V Coil Heater for 575V Power part number
38.00	500	E315614	E315619	E315624
44.00	600	E315615	E315620	E315625
68.00	1000	E315616	E315621	E315626
80.00	1200	E315617	E315622	E315627
98.00	1500	E315618	E315623	E315628

Coil Heater Overall Length in	Coil Heater Rated Watts	230V Coil Heater for 230/460V Power part number	190V Coil Heater for 380V Power part number	288V Coil Heater for 575V Power part number
50.00	375	E315629	E315638	E315647
56.00	425	E315630	E315639	E315648
64.00	475	E315631	E315640	E315649
68.00	500	E315632	E315641	E315650
80.00	600	E315633	E315642	E315651
83.00	625	E315634	E315643	E315652
92.00	700	E315635	E315644	E315653
98.00	725	E315636	E315645	E315654
110.00	800	E315637	E315646	E315655

STS Series

USER MANUAL

SPX COOLING TECHNOLOGIES, INC.

7401 WEST 129 STREET
OVERLAND PARK, KS 66213 USA
913 664 7400 | spxcooling@spx.com
spxcooling.com

E329630 | ISSUED 02/2020
© 2020 SPX COOLING TECHNOLOGIES, INC | ALL RIGHTS RESERVED
In the interest of technological progress, all products are subject to design and/or material change without notice.

