

Sound Solutions

Sometimes, being quiet is every bit as important as being cool. For applications where sound reduction is imperative, Marley NC cooling towers are equipped with a choice of best-in-class low sound options.

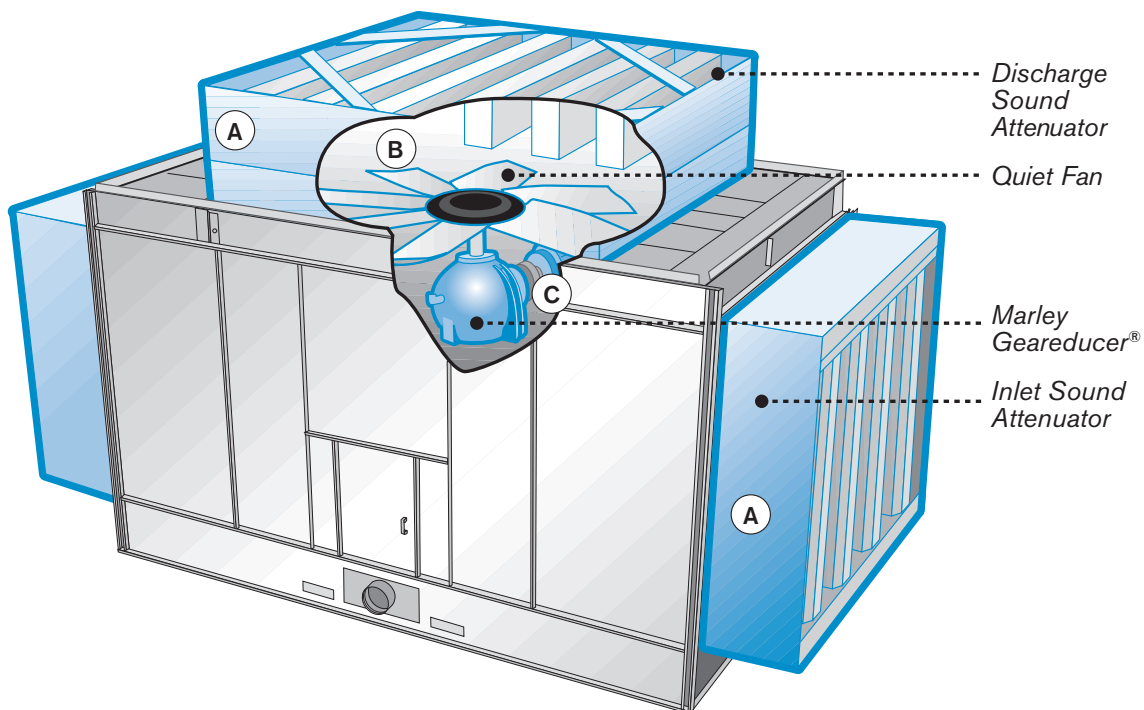

A Sound Attenuators

Sound attenuator sections can be installed on both the discharge and inlet areas of cooling towers. For maximum noise reduction, two stages of attenuators can be installed as an option for the most stringent noise control.

Unlike others, Marley inlet attenuators have negligible effect on performance, however, discharge attenuators may necessitate an increase in tower size or fan power.

B Fan

Fan noise is typically the largest noise contributor. By installing premium efficiency fans, sound levels can be lowered significantly.



Quiet Fan

Suitable for most noise-sensitive situations.



Ultra Quiet Fan

This fan can reduce sound levels even further with negligible performance reduction.

C Drive and Motor

Marley Geareducers are engineered to be the quietest gear drive system available and are typically quieter than belt drives.

Marley Variable Speed Drives

minimize a tower's sound level during periods of reduced load and/or reduced ambient temperature.

Common Applications

- **Hospitals**
Noise concerns may be paramount near medical facilities where quiet and rest are necessary.
- **Universities and Office Buildings**
Whenever HVAC equipment is near people, unwanted noise may be a concern. For example, conducting a meeting or teaching a class in a room with cooling equipment outside can be an unwelcome distraction.
- **Hotels and Residential Areas**
At night, ambient noise levels are lower, which may make a cooling tower seem louder to anyone nearby. Hotel guests or residential neighbors shouldn't have to contend with cooling equipment cycling on and off.

The Marley "Quiet Package"

Marley Low-Sound fans are standard on all NC models ensuring quiet operation in our most economical configuration. The Marley "Quiet Package" includes the affordable Quiet Fan mechanical option, a combination of motor, gear ratio, fan blade count and blade profile optimized to achieve the lowest possible sound levels while maintaining efficiency at a reasonable cost.

For more severe cases requiring the lowest possible fan sound levels, the Marley "Ultra Quiet" fan option is now available on most NC models.

Have an Existing Cooling Tower that's Too Loud?

Most of these options can be retrofitted to existing Marley NC cooling towers back to year 2000 models with few modifications. Contact your local Marley sales representative to find out how.



All of these options are CTI Certified for thermal performance.

SPX COOLING TECHNOLOGIES, INC.

7401 WEST 129 STREET
OVERLAND PARK, KS 66213 USA
913 664 7400 | spxcooling@spx.com
spxcooling.com

IN-SOUND-17 | ISSUED 03/2017
COPYRIGHT © 2017 SPX CORPORATION

In the interest of technological progress, all products are subject to design and/or material change without notice.

