

Structural Connections

What are Shear Plates?

Shear plates increase the load-bearing capability of joints in wood structures by increasing the bearing area. Design standards for wood structures recognize and quantify the ability of shear plates to strengthen a joint.

In addition, properly designed shear plates provide joint stability even if the bolted connection becomes loose because of wood shrinkage or minor movement between the members making up the joint. The bolt acts merely to clamp the joint system together.

Proper Use of Shear Plates can be Critical to Cooling Tower Life

The strength of timber connections is impacted not only by the lumber species, but also by fastener type, direction of load, fastener spacing and distance from the end of the member; as well as service conditions such as moisture content, temperature and duration of load. Most structural connections in wood cooling

towers are made with machine bolts. However, the strength of the connection can be more than doubled by the use of shear plates in the joint. The use of shear plates is approved by both the National Design Specification for Wood Construction (NDS) and by CTI STD-119.

Increased strength developed by the use of shear plates is particularly important in highly loaded connections such as:

- Connections subjected to high operating and live loads (fill and mechanical equipment supports, fan deck supports, wind load diagonals, etc.).
- Connections where the bolted joint strength is reduced due to fastener spacing or end distance such as end and side wall girt connections subjected to wind load.

The NDS also requires that the timber members in the joint be fabricated with “grooves conforming accurately to the dimensions and shape of the connector used.”

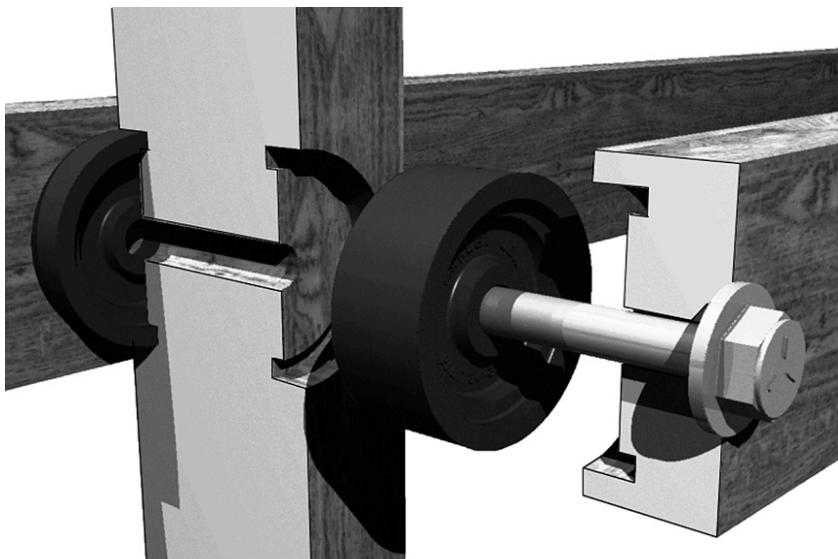

The Marley Difference

Structural shear plates are used in all critical framing joints on Marley cooling towers. These shear plates are manufactured to Marley specifications of high-strength glass-filled nylon, which is an inert material. As required by NDS, these shear plates fit into recesses that conform precisely to the shape of the shear plate, which are cored

into the wood members at the factory before preservative treatment. Obviously, the tooling and fabrication necessary to accommodate shear-plate-type construction adds to our cost. However, its net value far exceeds its cost because it insures that the structure we provide for our customers will be serviceable for many years to come.

Typically, other cooling tower manufacturers provide fewer structural connectors, usually limited only to those joints in which the use of bolts alone is obviously inadequate. Some manufacturers use none!

Recommendation

Whenever you evaluate your cooling tower quotations, ask your vendors:

- 1 If they use shear plates;
- 2 In how many and in what types of connections shear plates are used;
- 3 If the timber members are fabricated to accurately conform to the shape of the connector used;

- 4 What material the shear plate is made of; and
- 5 Whether they have test data or recognized standards to verify the load carrying capacity of their connectors.

How to Specify

Include in your specification language similar to the following:

Critical framing joints shall be made with structural shear plates made of glass-filled nylon, or equally inert material of comparable strength. Framing specific to those joints shall be factory-fabricated before treatment to accept the insertion of shear plates, as required by NDS and as approved by CTI Bulletin STD-119. wCooling tower designer shall maintain structural design calculations for review by the purchaser.

To order copies of CTI publications, contact:

Cooling Technology Institute
PO Box 73383
Houston, Texas 77273

281 583 4087
www.cti.org

SPX COOLING TECHNOLOGIES, INC.

7401 WEST 129 STREET
OVERLAND PARK, KS 66213 USA
913 664 7400 | spxcooling@spx.com
spxcooling.com

ITEM-S-3B | ISSUED 03/2017
COPYRIGHT © 2017 SPX CORPORATION

In the interest of technological progress, all products are subject to design and/or material change without notice.

