



MANUAL

*Installation, Operation
and
Maintenance Instructions*



SERIES 4700
STEEL AQUATOWERS

APRIL, 1984

MANUAL 92 - 1313

OM-4700D

5800 Foxridge Drive – P.O. Box 2912 – Mission, Kansas 66201

INSTALLATION, OPERATION, MAINTENANCE, DISASSEMBLY – STEEL AQUATOWERS

Installation, Operation and Maintenance Instructions

SERIES 4700

STEEL AQUATOWERS

RECEIVING INSPECTION

The tower is shipped complete with the motor in a carton and miscellaneous parts packaged within the tower. Check motor nameplate to be sure that power supply and motor have the same characteristics. Check miscellaneous parts as well as over-all tower condition for any damage in transit.

TOWER LOCATION

NOTE: The cooling tower must be located at such distance and directions from any air conditioning or ventilating system air intake ducts as to be safe with respect to fire or clean air considerations. It is recommended that the purchaser obtain the services of a Licensed Professional Engineer or Registered Architect to certify that the location of the tower is safe and in compliance with applicable air pollution and fire codes and clean air considerations.

Locate so prevailing wind will blow into the louvered face. Direct fan discharge away from building surfaces to eliminate the possibility of discoloration. Locate so there is free flow of air to and from the tower. Allow clearance on all sides for maintenance.

INDOOR INSTALLATION

A duct is required from the tower air discharge to the outside. In some cases it may also be desirable to install an inlet air duct. If ducts are used, the total draft loss should not exceed .10" water pressure. Draft losses can be minimized by:

- Using 20% oversize ducts.
- Avoiding sharp turns or abrupt changes in size.
- Keeping duct length to a minimum.
- Increasing the area of screened or louvered opening so the net free area is at least 20% greater than the tower discharge opening area.

Ducts should be attached to the tower using rubber or canvas connections. Access openings for servicing the mechanical equipment must be provided if air discharge ducts are installed. If the duct discharges into the prevailing wind, it may be necessary to install a windbreak or an elbow to serve as a deflector. Ducts installed on towers with year around usage should be water tight and insulated to prevent condensation.

TOWER INSTALLATION

Install tower in a level position on a stable foundation. Anchor tower by bolting to the foundation through holes provided in tower skid. Four 3/8" diameter bolts (by others) are required.

PIPING TO TOWER (Summer Temperature Conditions)

- Sufficiently sized piping should be used to provide minimum friction loss.
- Connect float valve to make-up water supply.
- Install bleed-off line. Bleed-off is the continuous wasting of a small amount of water during operation to retard scale and corrosion. A bleed-off line can be installed at any point in the system, however, the best point is in the hot water line near the top of the

tower so water will be removed when the pump is operating. A copper tube, pinched down, or a pet cock can be used.

PIPING TO TOWER (Winter Freezing Conditions)

- Where operating conditions require tower use during freezing weather, it is recommended that the towers be installed for "dry basin" operation. See Detail "A".
- Provide an inside open type storage tank with a capacity of four times the cooling tower GPM.
- Connect tower suction to storage tank.
- Install make-up water, bleed-off, overflow and drain lines on tank.
- Insulate and heat water lines exposed to freezing temperatures.

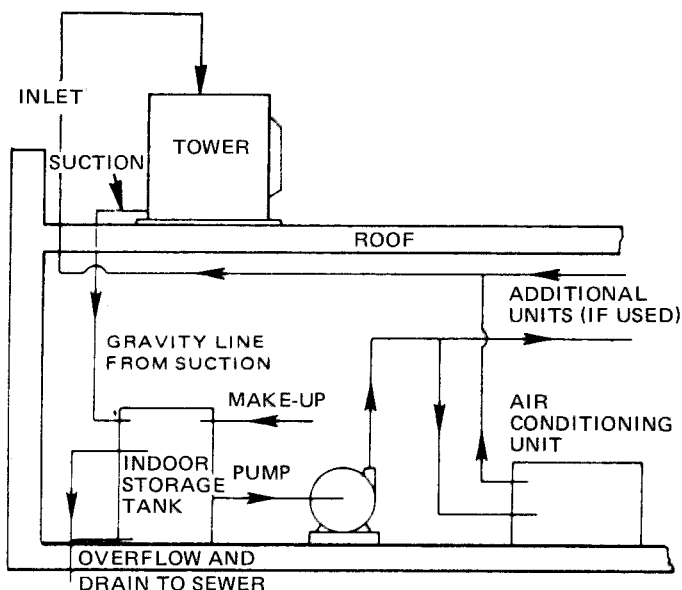

DETAIL "A" Flow Diagram for a Cooling Tower with Indoor Storage Tank. (Piping is Arranged So That Tower Basin Will Drain When Pump Is Shut Off.)

MECHANICAL EQUIPMENT INSTALLATION

MOTOR, SHEAVE AND V-BELT INSTALLATION

- Check the motor nameplate to be sure its voltage, phase and frequency ratings are the same as the power supply.
- Check to insure that fan is tightly secured to bearing housing shaft and free to rotate and that bearing housing is secured to its support.
- Bolt motor to motor base with four bolts, standard cut washers, lock washers and nuts (see Detail "B", Page 2). The adjusting bolts may need to be loosened so the motor base can be raised to allow for enough working room under the motor base to tighten bolts attaching motor.
- Install motor sheave and align it with fan sheave. A plumb line will be helpful in aligning sheaves. See Detail "C", page 2. *(continued on page 4)*

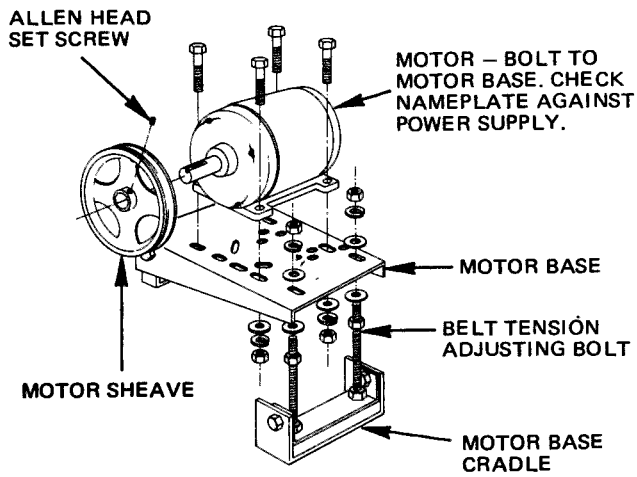

DETAIL "B"

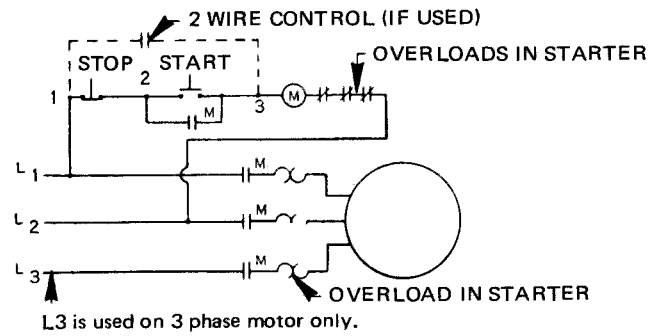

Showing Overload in Starter
DIAGRAM "D"

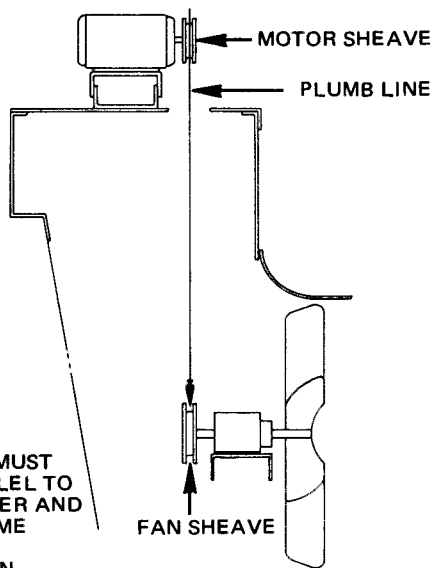

NOTE: SHEAVES MUST BE PARALLEL TO EACH OTHER AND IN THE SAME PLANE OF OPERATION.

DETAIL "C"

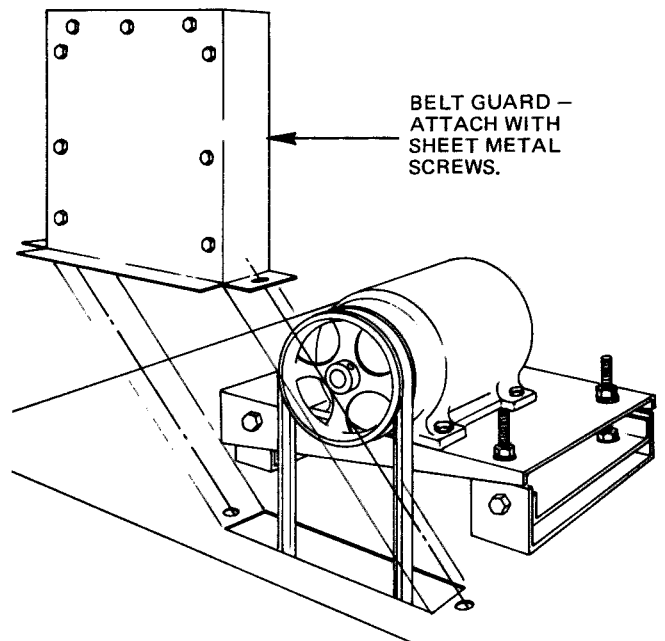

Belt Guard Installation
DETAIL "E"

WIRING DIAGRAM CAPACITOR START SINGLE PHASE MOTORS, REVERSIBLE, DOUBLE VOLTAGE

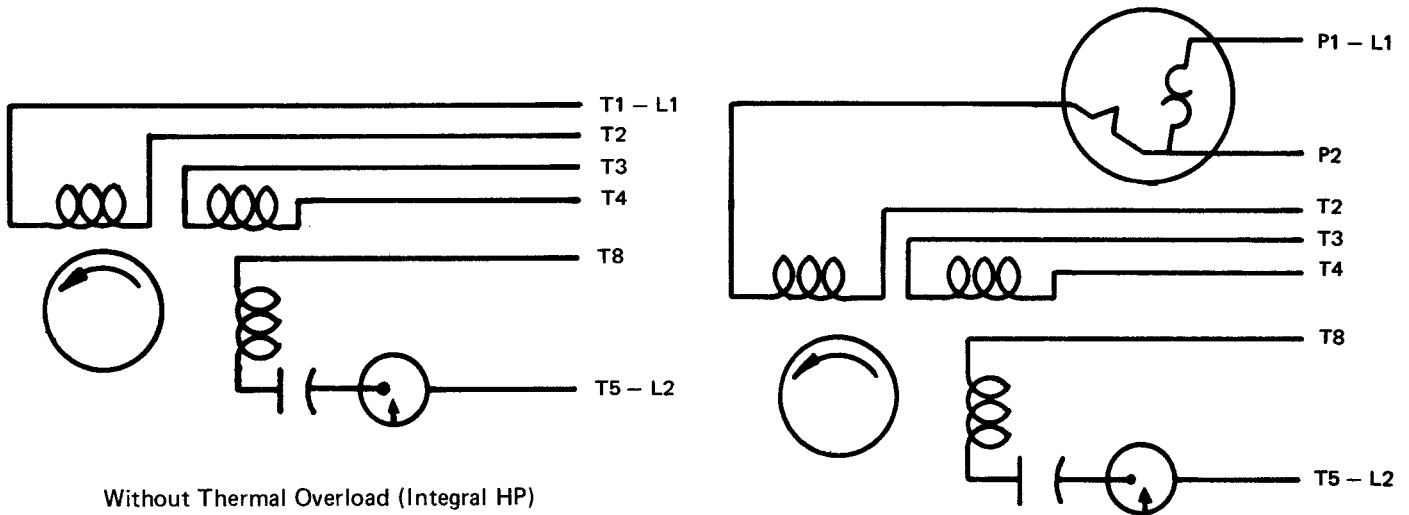

Without Thermal Overload (Integral HP)

HIGH VOLTAGE

1. Connect T1 and L1 and insulate.
2. Connect T2, T3 and T8 and insulate.
3. Connect T4, T5 and L2 and insulate.

LOW VOLTAGE

1. Connect T1, T3, T8 and L1 and insulate.
2. Connect T2, T4, T5 and L2 and insulate.

With Thermal Overload (Fractional HP)

HIGH VOLTAGE

1. Insulate P2.
2. Connect T2, T3 and T8 and insulate.
3. Connect T4, T5 and L2 and insulate.
4. Connect P1 and L1 and insulate.

LOW VOLTAGE

1. Connect P1 and L1 and insulate.
2. Connect P2, T3 and T8 and insulate.
3. Connect T2, T4, T5 and L2 and insulate.

GENERAL:

Colors may be substituted for numbers as follows:

T1 – Blue	T5 – Black
T2 – White	T6 – Red
T3 – Orange	P1 – No Color Assigned
T4 – Yellow	P2 – Brown

To reverse rotation, interchange leads T5 and T8.

WIRING DIAGRAM 3 PHASE SINGLE SPEED WYE WOUND MOTORS

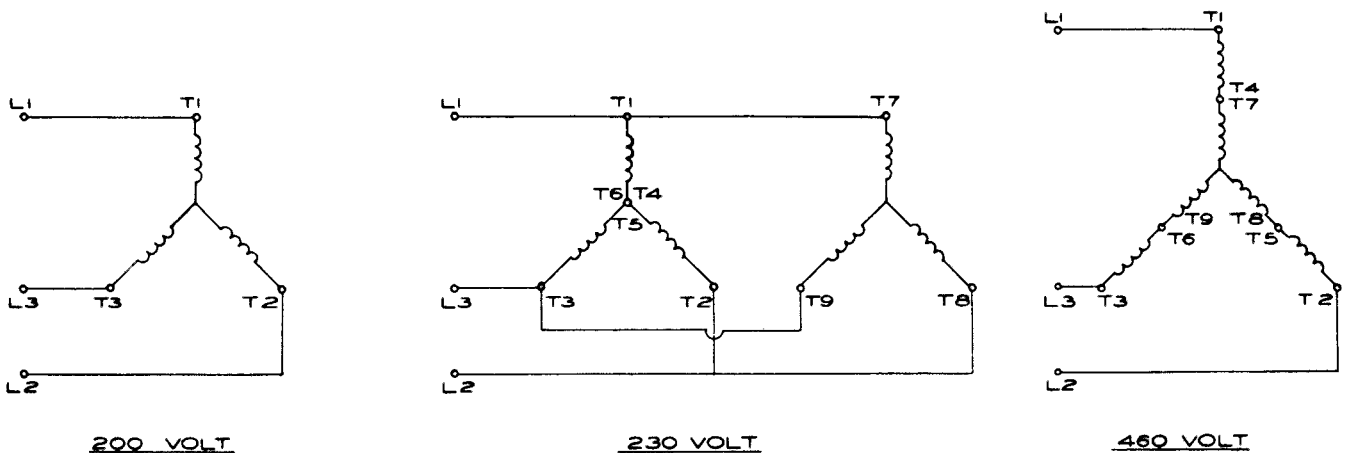

200 VOLT

230 VOLT

460 VOLT

To reverse rotation, interchange any two of three power leads.

5. Install V-belt and adjust tension by means of belt tension adjusting bolts. A correctly tensioned belt does not slip when the fan is started; and, when running, the "tight" side is straight between sheaves. The "slack" side will have a slight bow. Correct tension can only be determined by trial runs at successively higher tensions until slipping has stopped.

A small further increase in tension should be made to account for normal belt stretch. Avoid over tensioning. Too much tension reduces bearing and belt life.

New belts must be retensioned after 8 to 12 hours operation since new belts stretch at a higher rate and "seat" into sheaves grooves.

6. Check to be sure bearing housing is filled to the proper level with SAE 20 weight mineral oil. For models 4790 and 4799, leave ¼" space above static oil level to allow for thermal expansion of the oil during operation.
7. Connect motor to power supply using wiring, switching, short circuit protection and overload protection in accordance with the National Electric Code and local requirements. Failure to wire the motor correctly will void its warranty. The overload protection for motors must be part of the control system. See Diagram "D", page 2.
8. Sleeve bearing motors are usually shipped without oil and must be oiled before operation. Use high grade turbine type mineral oil of viscosity recommended by the motor manufacturer. Ball bearing motors are lubricated for the initial operation by the manufacturer, however, the motor bearing housing should be examined for presence of adequate grease before motor is placed in operation. Use grease recommended by the motor manufacturer. Chevron SRI-2 is recognized by many motor manufacturers as a suitable grease for ball bearing motors on cooling tower service. Refer to Marley Electric Motor service manual for lubricating procedures.
9. Install belt guard using sheet metal screws. See Detail "E", page 2.

STARTING AND OPERATION INSTRUCTIONS

1. Wash foreign matter from fill and basin.
2. Fill circulating system with water. Fill the cold water basin with water until level is approximately 1½" below rim of overflow cup.
3. Start pump and adjust float valve. Maintain 4" of water on model 4705, 4707, 4710 and 4515, and 5" in the depressed section of the basin on models 4720 thru 4799. *Caution: Hot water temperatures exceeding 125°F could damage PVC (plastic) fill.*
4. Check bleed-off line to make sure water is being discharged during operation.
5. Check fan for free rotation and oil level in bearing housing (see maintenance instructions). Start motor and check direction of rotation. Fan must rotate clockwise when viewed from the fan discharge side. If the rotation is incorrect, change any two of the three motor leads.

Depth of water in hot water basin should be uniform. If the basin overflows, reduce the flow rate. Do not pump more water than design capacity.

7. Do not cycle the motor so that the total of the starting times exceeds 30 seconds each hour.

MAINTENANCE INSTRUCTIONS

MOTOR

Lubricate the motor according to the motor manufacturer's instructions shipped with the motor.

Remove any oil, dust or scale deposits from the motor. They can cause excessive insulation temperatures.

Refer to Marley Electric Motor service manual for maintenance and lubrication information.

BEARING HOUSING

Lubricate bearing housing with SAE 20 weight mineral oil. Refer to Item 6 under Mechanical Equipment Installation, page 4.

BELT TENSION

Check belt tension every two to three weeks during peak operating season. Refer to V-belt installation, Item 5, page 4.

FLOAT VALVE

Check float valve periodically for proper operation and maintenance of water level.

BASIN AND SUCTION SCREEN

Drain and clean cold water basin and suction screen periodically.

BLEED-OFF

Check the bleed-off for continuous water discharge during operation.

WATER TREATMENT

The following table shows the proper amount of bleed-off:

COOLING RANGE DEGREES F	BLEED-OFF IN PERCENT OF TOTAL GPM
6	.15
7½	.22
10	.33
15	.54
20	.75

CHEMICAL TREATMENT

The quality of many waters is such that chemical treatment for scale prevention or removal will not normally be required if adequate bleed-off is maintained. In areas where bleed-off alone is not sufficient to prevent objectionable scale or corrosion, use a simplified phosphate treatment or contact a reputable water treatment company for aid.

Slime, a gelatinous organic growth, and algae, a green moss, may grow in the cooling tower or heat exchangers. Their presence can interfere with cooling efficiencies. Proprietary compounds are available from water treating companies for the control of slime and/or algae, however, compounds which contain copper must be used with care. Copper can accelerate corrosion of steel, iron, aluminum and galvanizing and should not be used in systems containing any of those materials. Chlorine and chlorine containing compounds are effective algicides and slimicides but excess chlorine can damage wood and other organic materials of construction. If used, chlorine should be added as intermittent (or shock) treatment only as frequently as needed to control the slime and algae, and free residual levels should not exceed one part per million parts water (1 ppm). Chlorine or chlorine containing compounds should be added carefully since very high levels of chlorine may occur at or near the point of entry into the circulating water system.

FOAMING

Foaming occasionally becomes a problem with certain water conditions when a new tower is put into operation. The condition is not normally persistent for an extended period, and foaming can be lessened by increasing bleed-off until condition is improved. If increased bleed-off does not lessen foaming sufficiently, a foam depressant chemical should be used. These are generally available through local chemical supply companies and some water treating companies.

SEASONAL SHUTDOWN INSTRUCTIONS

Drain the tower basins and all exposed piping. Leave the basin drain open. Water may be left in cold water basin if tower is located in a non-freezing area.

During shutdown, clean the tower and make any necessary repairs. Apply protective coating as required to all metal parts. Particular attention should be given to bearing housing supports.

MECHANICAL EQUIPMENT

V-BELTS AND SHEAVES

1. At shutdown, remove and store belts in a cool, dark, dry room. Clean and coat sheave grooves with rust preventive, lacquer, or paint.
2. Before putting belts back on sheaves, remove rust preventive. Replace belts that show excessive wear.
3. When putting tower back into service refer to "Mechanical Equipment Installation", page 1, 2, 3 and 4, for belt installation and tensioning instructions.

BEARING HOUSING, Oil Lubricated Type

1. At shutdown, operate until oil is warm; drain and refill. Use SAE 20 weight mineral oil.
2. Each month, drain water condensate at the drain plug. Check oil level on oil reservoir cup and add oil if necessary.
3. At start-up, operate until oil is warm; drain and refill.
4. Bearing housing may be refilled at point where copper line from oil reservoir cup connects to bearing housing.

ELECTRIC MOTOR

Clean and lubricate motor at close of each operating season. Refer to motor manufacturer's recommendations.

Do not start motor without determining that there will be no interference with free rotation of the fan drive.

The motor should be run for three hours at least once a month. This serves to dry out windings and relubricate bearing surfaces. Refer to Marley Electric Motor service manual.

At start of new operating season, make sure bearings are adequately lubricated before returning motor to service.

PROLONGED SHUTDOWN

If shutdown period is longer than seasonal, contact your Marley sales office or representative for additional information.

When writing for information or when ordering parts, always mention tower serial number shown on the nameplate.

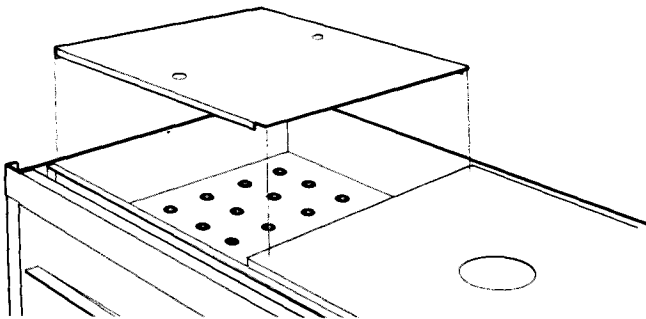

Hot Water Basin Cover — 16 gauge HMG — Covers open hot water distribution basin

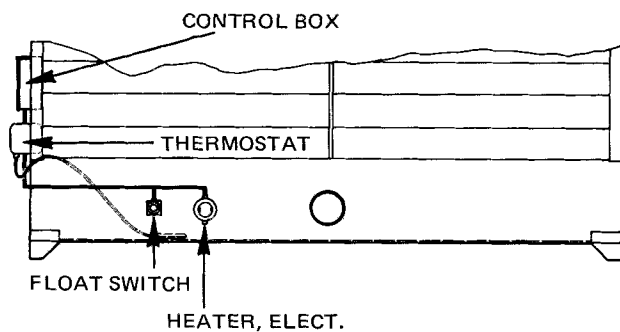

Electric Heater System — To prevent freezing water in the cold water basin when it can not be drained

OPTIONAL EQUIPMENT

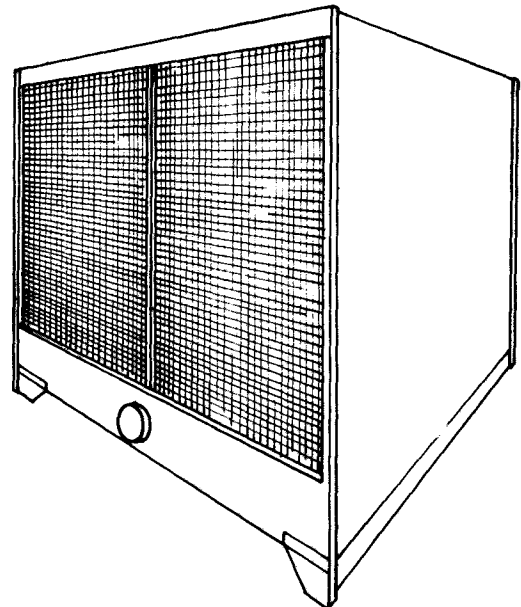

Air Inlet Screens — Rectangular assembly consisting of No. 2 mesh 16 gauge HMG screen bounded on four sides with 16 gauge HMG U-edging.

DISASSEMBLY AND REASSEMBLY INSTRUCTIONS

(See Detail "F")

Never disassemble the Aquatower further than necessary. For example, if removal of the motor base is sufficient to get the tower to the installation site, remove only that part. When disassembling, remember how each part is screwed, bolted and set in place. Fasten screws and bolts for each part with each section. Be careful not to mar galvanized coating. Sections of the tower are sealed with polyurethane sealer. Remember areas to be resealed. (Use Vulkem or equivalent.)

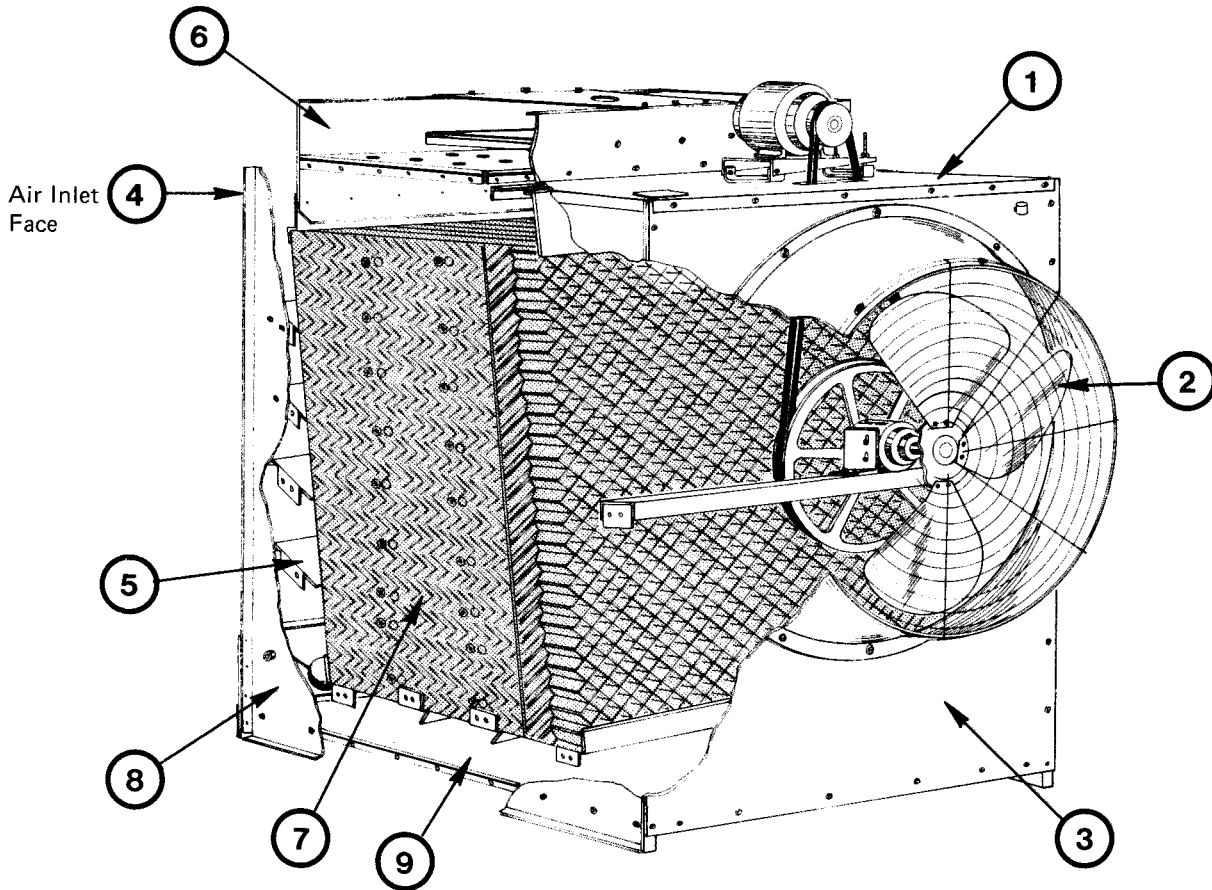

DETAIL "F"

DISASSEMBLY

1. Remove top sheet.
2. Remove fan guard, fan, bearing housing, and bearing housing support channel.
3. Remove fan sheet with fan cylinder intact.
4. Remove tie rods. (Models 4755 thru 4799)
5. Remove louvers, louver column, and stiffener channel above louvers. (Smaller models do not have louver column or stiffener channel)
6. Remove hot water distribution basin. Disassemble if necessary.
7. Remove fill and eliminators.
8. Remove side casing sheets.
9. Disassemble cold water collection basin and skids.

REASSEMBLY

Reassembly of the Aquatower is the reverse of the steps noted above.

IMPORTANT

The following precautions are important:

1. Fill must be installed level to assure full tower performance.
2. Bolts and screws which use sealing washers under head should be tightened securely to prevent leaks.
3. Be sure mechanical equipment is installed correctly and fan rotates freely.
4. Be sure to reseat the basins and every location sealer was used before disassembly.

TOWER TROUBLE TIPS

TROUBLE	CAUSE	REMEDY
Unusual Motor Noise	Motor running single-phase	Stop motor and attempt to start it. Motor will not start if single-phased. Check wiring, controls and motor.
	Motor leads connected incorrectly	Check motor connections against wiring diagram on motor.
	Ball Bearings	Check lubrication, Replace bad bearings.
	Electrical unbalance	Check voltage and currents of all three lines. Correct if required.
	Rotor unbalance	Rebalance.
Motor Runs Hot	Motor overload, wrong voltage or unbalanced voltage	Check voltage and current of all three lines against nameplate values.
	Wrong fan rpm	Check nameplate rpm of motor and sheave ratio against parts list. Measure rpm.
	Bearings overgreased	Remove grease reliefs, Run motor up to speed to purge excessive grease.
	Rotor rubs stator bore	If not poor machining, replace worn bearing.
	Wrong lubricant in bearings	Change to proper lubricant. See motor manufacturer's instructions.
	One phase open	Stop motor and attempt to start it. Motor will not start if single-phased. Check wiring, controls and motor.
	Poor ventilation	Clean motor and check ventilation openings. Allow ample ventilation around motor.
	Winding fault	Check with Ohmmeter.
	Insufficient grease	Remove plugs and regrease bearings.
	Too frequent starting	Limit accumulative starting time to a total of 30 seconds each hour.
Bearings damaged	Replace bearings.	
Unusual Fan Drive Vibration	Loose bolts and cap screws	Tighten all bolts and cap screws on all mechanical equipment and supports.
	Worn fan shaft bearings	Check shaft to see if it is loose.
	Bent shaft	Replace.
	Misalignment	Make sure fan and motor are straight and properly aligned.
	Belt	Check belt for proper tension.
	Unbalanced motor	Disconnect load. Remove sheave, tape 1/2" key in keyway and operate motor. If motor still vibrates, rebalance rotor.