



MANUAL

SERIES **NC**[®] STEEL
DOUBLE-FLOW[®]
Series 8800 and 8900

*Operation and Maintenance
Instructions*

MANUAL 92 - 1329

AUGUST, 1984

OM-NC-8800 & 8900A

OPERATION & MAINTENANCE INSTRUCTIONS—SERIES 8800 AND 8900 NC STEEL DOUBLE-FLOW

5800 Foxridge Drive — P.O. Box 2912 — Mission, Kansas 66201

SERIES 8800 and 8900 NC STEEL DOUBLE-FLOW

TABLE OF CONTENTS

Pre-starting Instructions	Page 3
Starting Instructions	Page 3
Operation	Page 4
Maintenance	Page 4
Water Treatment, Bleed-off, Foaming	Page 5
Spare Parts	Page 6
Seasonal Shutdown Instructions	Page 6
Inspection & Maintenance Schedule	Page 6
Motor Lubrication — Shaft Extension End Bearing	Pages 7 & 9
Recommended Conduit Installation	Pages 8 & 10
Tower Trouble Tips	Pages 11 & 12

—IMPORTANT—

Always refer to tower serial number in any correspondence. Serial number is stamped on the Marley nameplate located on or above the tower access door.

SERIES NC[®] STEEL DOUBLE-FLOW[®] Series 8800 and 8900 Operation and Maintenance Instructions

GENERAL

NOTE: The cooling tower must be located at such distance and direction from any air conditioning or ventilating system air intake ducts as to be safe with respect to fire or clean air considerations. It is recommended that the purchaser obtain the services of a Licensed Professional Engineer or Registered Architect to certify that the location of the tower is safe and in compliance with applicable air pollution and fire codes and clean air considerations.

These instructions have been prepared to assist the tower owner and operator in obtaining the best results and long life from his Marley tower. Service manuals on mechanical equipment and parts manual sheets are sent with these instructions and should be read before the tower is put in service.

Any questions concerning the operation and/or maintenance not covered by these instructions should be referred to the nearest Marley representative. *When writing for information or ordering parts, always mention tower serial number shown on the nameplate.*

PRE-STARTING

When a cooling tower is started for the first time or after a long shut down period, it should be cleaned and inspected. All operating assemblies must be inspected before they are placed in operation. Following is a list of functions to be performed before starting the tower:

1. Remove items shipped in cold water basin and install per installation drawings shipped with tower.
2. All models ship with top fan ring and fan guard detached. Install per installation drawing shipped with tower.
3. Clean any dirt, leaves or foreign matter from the hot water basins, cold water basin and air inlet louvers. See that metering orifices in hot water basins are in place and open. Remove any debris from suction screen and sump in the cold water basin. See that sump screens are installed properly.
4. Wash down fill and water basins using a hose to run water through the hot water basins. Avoid directing high pressure water stream onto fill or eliminators. Drain cold water. Remove any debris. Clean outlet screens as required.
5. Before operating the motor, check that overload protection has been installed in all three lines. Overloads should be at the same ambient temperature as the motor. Do not use ambient compensated overloads. Also, check the wiring system for grounds and check the resistance between all leads for open, bad or incorrect connections. (See installation section of Marley Service Manual on Electric Motors.)
6. Grease motor if there are grease fittings or plugs. The motors should be greased in accordance with

the motor manufacturer's instructions. Chevron SRI-2 is recognized by many motor manufacturers as a suitable grease for ball bearing motors on cooling tower service. Refer to Marley Electric Motor Service Manual and Detail "A" or Detail "B", page 7 or page 9, for greasing procedure for appropriate series tower.

7. Test motor insulation resistance with a "megger". (See maintenance section of Marley Service Manual on Electric Motors.)
8. Check oil in Geareducer by draining off a sample and examining for water. Drain, flush and refill with oil if water is present. Check Geareducer and oil line (optional equipment) fittings for leakage and correct as required. Add oil if level is low. *Check oil level at external sight glass or dip stick (optional equipment) to be sure full mark corresponds with full level in Geareducer.* (See Geareducer Service Manual.)
9. Check the fan for free rotation and ample tip clearance. Clearance between the ends of the blades and the cylinder should be a minimum of 1/8". Check the fan hardware for proper torque. (See Fan Service Manual)
10. Be sure float valve for make-up water is operating freely and float rod is in a vertical position.
11. Check, and tighten as necessary, structural bolting in mechanical equipment supports and Geareducer mounting bolts. Inspect drive shaft couplings and check alignment of shafts. All cap screws and set screws must be tight. (See Drive Shaft Service Manual.)

STARTING

FILLING THE WATER SYSTEM

Fill the cold water basin and connected pipe system with water until the operating water level is reached. (See "Operation — Cold Water Collecting Basin" page 4.) The float valve should be adjusted to maintain water at the required level, then basin should be filled to overflow level.

NOTE: If tower is equipped with a standard side-suction connection, vent any accumulated air from the top of the suction hood by removing one or both tap screws provided at that location. Replace these tap screws when venting is complete.

Open the hot water valve; then prime and start the circulating water pump. The water depth in the hot water basins should be between 2.8 and 5.4 inches.

CAUTION: Hot water temperatures exceeding 125°F could damage PVC (plastic) fill.

STARTING THE FAN

Fan must run clockwise when viewed from above and discharge the air up. Directional arrows on the fan blades show the proper rotation.

If the motor is not loaded in accordance with the contract horsepower, adjust fan blade pitch. (See operation section of Marley Service Manual on Electric Motors and Fan Service Manual.)

OPERATION

CAUTION: *Do not cycle the motor so that the total of the starting time exceeds 30 seconds each hour. Refer to Marley Electric Motor Manual.*

FAN DRIVE

If a two speed motor is used, allow a time delay of a minimum of 20 seconds after de-energizing the high speed winding and before energizing the low speed winding. Tremendous strains are placed on driven machinery and motor unless the motor is allowed to slow to low speed rpm or less before the low speed winding is energized. When changing fan direction of rotation, allow a minimum of two minutes time delay before energizing the fan motor.

HOT WATER DISTRIBUTION BASINS

To obtain maximum performance, maintain equal water flow and distribution over the basins. If all the metering orifices are clean and in place, equal water depth (2.8 to 5.4 inches) in both basins will indicate even distribution. If a major change in the quantity of water circulated over the tower is made, it may be desirable to change the orifice size to provide adequate water break-up and maintain the proper water level. Consult the Marley sales office or representative in your area if a change in circulating water rate is being considered.

COLD WATER COLLECTING BASIN

Normal operating water level in the collecting basin at bottom of tower is 1½ to 2 inches of water in the basin area under the fill. Maintain sufficient depth to prevent air from entering suction line under normal operation, but not so deep that water is lost out overflow when tower is shut down. Maintain water at design operating depth for maximum performance.

WATER MAKE-UP AND BLEED OFF

The volume of make-up water that is required to maintain adequate water depth in the cold water collecting basin depends upon the evaporation loss, drift loss and bleed-off. Water for make-up averages 1½ % of the tower water circulated for a cooling range of 10°F. For additional information see section on "Water Treatment", page 5.

WINTER OPERATION

During periods of low temperature operation (36° to 40°F and below), ice will form on the relatively dry parts of the tower that are in contact with the incoming air. Primarily, this includes the louvers and adjacent structural framing.

Ice forming characteristics on any given tower will vary, depending on velocity and direction of wind, circulating water rate and heat load. Ice formation may be controlled by regulating air and water flow through the tower by one or more of the following procedures:

1. Shut down the fan. This reduces the cooling rate to a

minimum and increases the quantity of warm water on the louvers to a maximum. Except for extreme cold conditions or extended freezing conditions, this procedure will normally control ice formation. For automatic operation, a timer switch can be provided to shut the fan down for a few minutes each hour.

2. If the tower has two-speed motors, operate the fan at half speed forward. This reduces the cooling rate (heat transfer) and increases the quantity of warm water on the louvers.

Under extended extreme cold conditions, it may be necessary to operate the fan in reverse. This forces warm air out through the louvers, melting any accumulated ice. Reversal may be at either full or half speed, however, full speed is recommended. Reverse operation of the fan should only be used to eliminate ice, not prevent it. *Reverse fan operation should not exceed 15 to 20 minutes.* Usually much less time than this is required to melt accumulated ice.

Do not operate tower with reduced water rate and/or no heat load. If a by-pass directly into the cold water basin is used, all water must be by-passed.

Avoid prolonged reverse operation of the fan since ice will build up on the blade tips or fan cylinder with resultant damage, and the moist air out through the louvers can create an accumulation of ice on surfaces exterior to the tower at the louvers.

See "Operation — Fan Drive", page 4, for fan speed change and reversing precautions.

INTERMITTENT WINTER OPERATION

When the cooling tower is operated intermittently during winter weather, it is necessary that the water be drained from the exposed piping and tower basin to insure protection against freezing and possible pipe rupture. Basin drains should be left open during winter shut-down periods to allow rain and melted snow to escape.

Basin heaters can be furnished to prevent freezing of water in the cold water basin.

If tower has oil gage and drain lines, check for condensate and drain as required. (See Geareducer Service Manual.)

TOWER MAINTENANCE

Maximum performance and service life depends on inspection and maintenance of all parts of the tower and its supply system. In most cases, a general tower inspection once a day should be sufficient. The schedule in Table I can be used by the operator to obtain continuously good performance with the least tower maintenance. Marley recommends setting up a regular inspection schedule to insure effective safe operation of the cooling tower. Keep continuous lubrication and maintenance records for each cooling tower. Regular inspection and repair of personnel safety items, indicated by asterisk in Table I, and a record of same is especially important. "SAFETY FIRST"

CAUTION! *The tower is designed so it can be maintained from the exterior and interior using a portable ladder. The top horizontal surface should not be used as*

a working platform unless an approved handrail is installed.

TOWER FRAMEWORK

Check structural steel bolted connections annually and tighten as required.

HOT WATER DISTRIBUTION BASINS

Metering orifices in the bottom of the hot water basin may be cleaned without shutting down any part of the tower. Remove dirt, algae, leaves, etc., which might get in basins or orifices. Orifices must be in place to assure proper water distribution.

BASIN COVERS (OPTIONAL)

Cooling tower distribution basin covers and hot water flumes are not designed for use as a walking surface or working platform. Decals have been installed on the hot water basin flumes to instruct personnel on top of tower not to use them as a walking surface or working platform. These decals read CAUTION: DO NOT USE THIS SURFACE OR BASIN COVERS AS A WALKING SURFACE OR WORKING PLATFORM. Maintain or replace decals as required to retain their legibility.

COLD WATER COLLECTING BASIN

The water level in the cold water basin should be checked daily. Inspect the suction screen each week, cleaning away any accumulated debris. Float valves or make-up water controls should operate freely and maintain the proper water level.

FILL

The fill must be kept clean. It is easier to prevent the deposition of foreign material than to remove it later. This is covered more completely in the "Water Treatment" section of this manual.

ELECTRIC MOTOR

Remove any oil, dust or scale deposits from the motor. They can cause excessive insulation temperatures. Check motor anchor bolts semi-annually and tighten as required.

Lubricate the motor in accordance with the manufacturer's recommendations. Refer to Detail "A" or Detail "B", page 7 or page 9, for appropriate series tower.

Refer to Marley Electric Motor Service Manual for maintenance and lubrication information.

GEAREDUCER

Geareducers supplied with new towers are filled with oil. Lubricating oil is not furnished with Geareducers supplied as spares or on replacement orders. Check Geareducer anchor bolts semi-annually and tighten as required.

Check oil level before start-up and make sure there are no oil leaks.

Run Geareducer at full speed, full load for one week or 150 hours. Change oil after this initial break in period to remove any foreign matter. See Geareducer Service Manual for recommended lubricants and instructions for changing oil.

Change oil at least every six months or 3000 hours of

operation.

FAN

Check fan operation daily. Inspect blades monthly and clean if necessary. (See Fan Service Manual.) Check fan assembly bolting semi-annually and tighten as required.

FLOW CONTROL VALVES

If tower has optional inlet valves by Marley, grease valve threads at zerk fitting semi-annually using rust inhibiting lithium base grease of NLGI No. 2 consistency.

PAINTING

All metal parts subject to corrosion and not galvanized should be cleaned and painted periodically with rust-resistant paint. Bitumastic base paints are good for this. The actual time between paintings is dependent upon the operating cycle, water conditions and climatic conditions.

WATER TREATMENT

BLEED-OFF

Bleed-off, or blowdown, is the continuous removal of a small portion of the water from the circulating system. The purpose of bleed-off is to prevent dissolved solids from concentrating to the point where they will form scale. As a guide, many waters can be allowed to concentrate two or three times without causing scale problems. The amount of bleed-off to hold concentrations to two or three depends upon the cooling range (hot water temperature minus cold water temperature). The following table shows amount of bleed-off required at three different cooling ranges.

COOLING RANGE (DEGREES F)	% OF CIRCULATING RATE TO BLEED-OFF TO MAINTAIN THREE CONCENTRATIONS	% OF CIRCULATING RATE TO BLEED-OFF TO MAINTAIN TWO CONCENTRATIONS
5	.18	.38
10	.38	.78
15	.58	1.18

EXAMPLE: 1200 GPM circulating rate, cooling range 10°F. To maintain three concentrations, the required bleed-off = 1200 x .0038 = 4.6 GPM

CHEMICAL TREATMENT

Bleed-off rate alone may not be sufficient to prevent scale or corrosion. In such cases, a reputable water treatment company should be contacted for assistance. Slime, a gelatinous organic growth, and algae, a green moss-like growth, may grow in the cooling tower or heat exchangers. Their presence can interfere with cooling efficiencies. Proprietary compounds are available from water treatment companies for the control of slime and/or algae. Compounds which contain soluble copper should be avoided. Chlorine and chlorine-containing compounds are effective algacides and slimicides and, at typical water treating concentrations, do not harm components in Series 8900 NC towers and most 8800 towers.

CAUTION: Some Series 8800 towers were furnished with asbestos fill and/or eliminators. If chlorine is used on towers having asbestos fill and/or eliminators the chlorine should be added as intermittent or shock treatment to a free residual level not exceeding one part per million parts of water (1 ppm).

FOAMING

Heavy foaming sometimes occurs when a new tower is put into operation. The type of foaming generally subsides after a relatively short period of operation. Persistent foaming can be caused by the concentration of certain combinations of dissolved solids or by contamination of the circulating water with foam-causing compounds. This type of foaming can sometimes be minimized by increasing the blowdown, but in some cases foam depressant chemicals must be added to the system. Foam depressants are available from a number of chemical companies.

SPARE PARTS

Marley maintains a stock of replacement parts for mechanical equipment at Olathe, Kansas. Shipment of these parts is normally made within ten days after an order is received. If emergency service is necessary, contact the Marley sales office or representative in your area for assistance.

To prevent prolonged shutdown periods in case of damage to mechanical equipment, it is suggested that the following spare parts be carried in the owner's stock:

1. One fan assembly.
2. One Geareducer assembly.
3. One driveshaft assembly.

Be sure to furnish the tower serial number when ordering any parts.

SEASONAL SHUTDOWN INSTRUCTIONS

Drain the tower basins and all the exposed piping. Leave the basin drain open.

During shutdown, clean the tower and make any necessary repairs. Apply protective coating as required to all metal parts. Particular attention should be given to mechanical equipment supports and drive shafts.

TOWER FRAMEWORK

Check structural steel bolted connections and tighten as required.

GEAREDUCERS

1. At shutdown, operate Geareducer until oil is warm; drain and refill. (See the lubrication section of Geareducer Service Manual for instructions on changing oil.)
2. Each month, drain water condensate from the lowest point of the Geareducer and, if tower is so equipped, from its oil system. Check oil level at Geareducer and add oil if necessary. Operate to re-coat all interior surfaces with oil.
3. Check Geareducer anchor bolts and tighten as required.
4. At start-up, operate until oil is warm; drain and refill.

FANS

Check fan assembly bolting and tighten as required.

FLOW CONTROL VALVES

If tower has optional inlet valves by Marley, grease valve threads at zerk fitting using rust inhibiting lithium base grease of NLGI No. 2 consistency and then open valve.

ELECTRIC MOTORS

Clean and lubricate motor at close of each operating season. Refer to motor manufacturer's recommendations. Check motor anchor bolts and tighten as required.

Do not start motor without determining that there will be no interference with free rotation of the fan drive.

The motor should be run for three hours at least once a month. This serves to dry out windings and relubricate bearing surfaces. Refer to Marley Electric Motor Service Manual.

At start of new operating season, make sure bearings are adequately lubricated before returning motor to service.

PROLONGED SHUTDOWN

If shutdown period is longer than seasonal, contact the Marley sales office or representative in your area for additional information.

TABLE I

INSPECTION & MAINTENANCE SCHEDULE
General Recommendations

(More frequent inspection and maintenance may be desirable)

1. Inspect for clogging
2. Check for unusual noise or vibration
3. Inspect keys and set screws
4. Lubricate (grease)
5. Visually check for oil leakage
6. Check oil level and oil seals
7. Check oil for water and dirt
8. Change oil, at least
9. Check water level
10. Check for leakage
11. Inspect general condition
12. Tighten loose bolts
13. Clean
14. Repaint
15. Completely open & close
16. Make sure vents are open
- *17. Inspect and repair for safe use

	FAN AND FAN GUARD	MOTOR	GEAREDUCER	DRIVESHAFT & GUARDS	DRIFT ELIMINATORS	FILL	COLD WATER BASIN	DISTRIBUTIONS BASINS	STRUCTURAL MEMBERS	CASING	FLOAT VALVE	SUCTION SCREEN	FLOW CONTROL VALVES (OPT.)	LADDERS & HANDRAILS*
					W	W		W				W		
1.	D	D	D	D					Y					
2.	S	S	S	S									S	
3.		S												
4.			D											
5.			W											
6.			M											
7.			S											
8.							D	D						
9.			W					S			S			
10.	M	S	S	S	Y	Y	Y	S	S	Y	Y	S	S	S
11.	S	S	S	S					S	R				
12.	R	S	R	R	R	R	S	R			R	W	R	
13.	R	R	R	R										
14.													S	
15.			M											
16.	Y			Y										Y

D-daily; W-weekly; M-monthly; Q-quarterly; S-semi-annually; Y-yearly; R-as required

8800 MODEL TOWERS

MOTOR RE-LUBRICATION INSTRUCTIONS

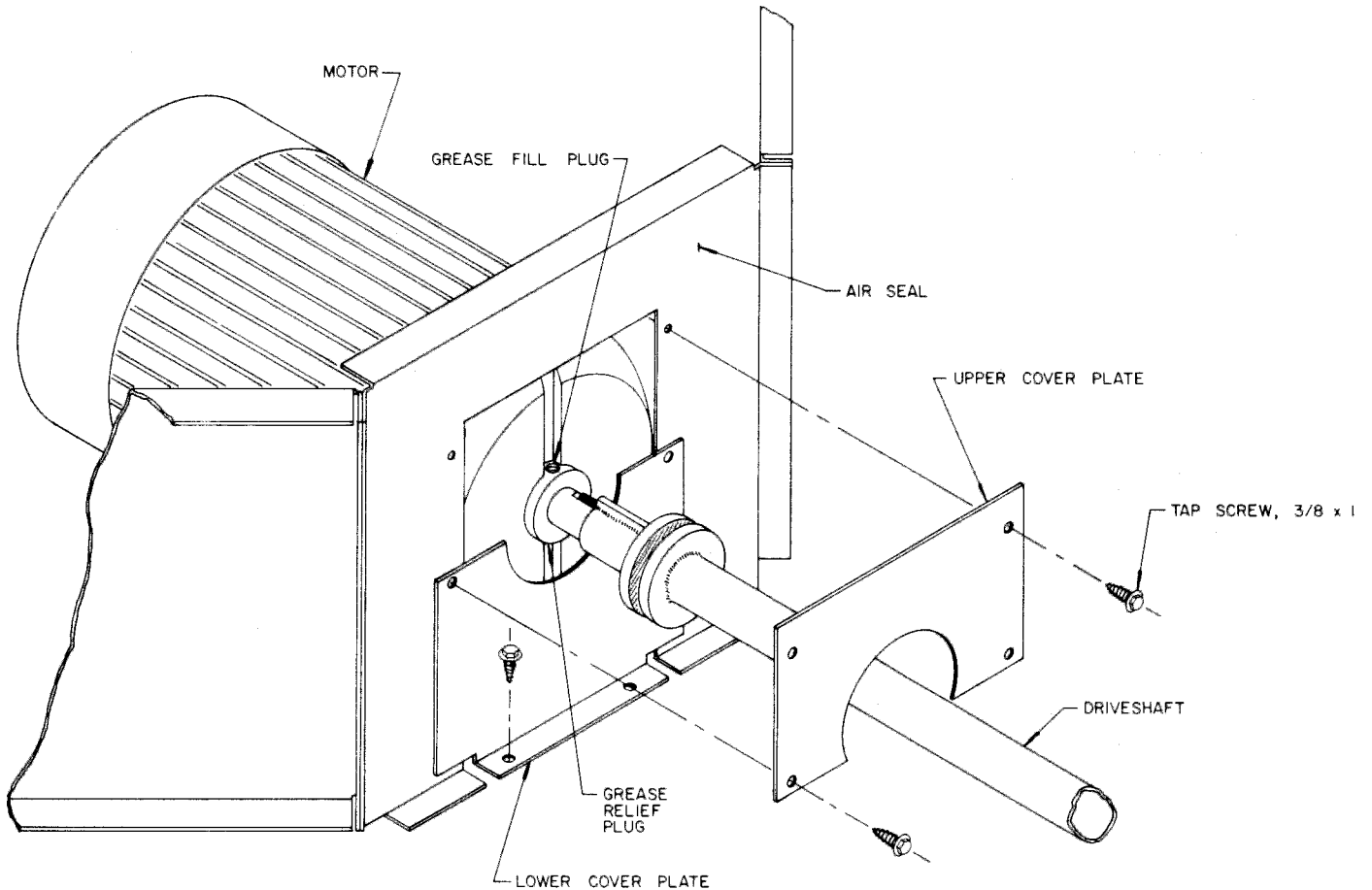

DETAIL "A"

Removal of cover plates from inside tower for access to shaft extension

CAUTION: *Open and tag out main power supply switch and make sure motor cannot be started.*

1. Remove cover plates as shown in Detail "A". Opposite end motor bearing is assessible from outside the tower.
2. Remove grease fill and relief plugs at both shaft extension end and opposite end bearings and remove hardened grease, using clean wire.
3. Insert grease fittings in grease fill openings and add grease until grease is forced out relief openings.
4. Replace fill plugs and operate mechanical equipment 30 minutes to one hour to purge excess grease at grease relief opening. *Shut down and tag out main power supply switch. Make sure motor cannot be started.*
5. Reinstall grease relief plugs and reinstall cover plates. See Detail "A".
6. Resume normal tower operation.

RECOMMENDED CONDUIT INSTALLATION FOR 8800 MODEL TOWERS

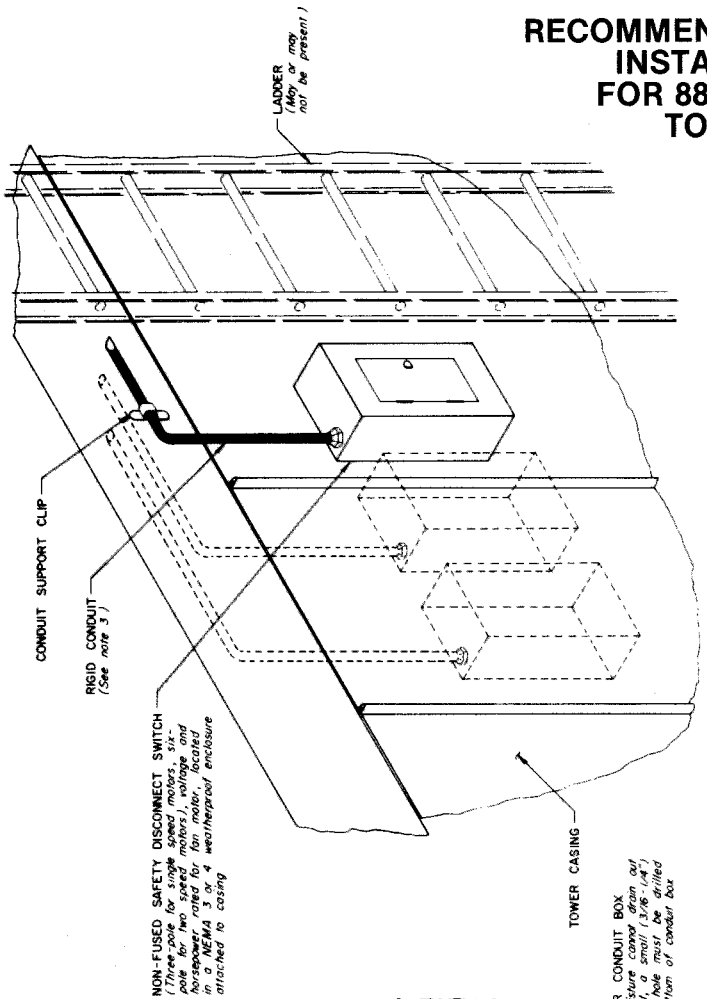

VIEW B-B

GENERAL NOTES

1. All conduit, connections, supporting clips, and safety switches are supplied by others.
2. All wiring must conform to local and national codes.
3. Conduit should be supported approximately every ten feet. **IMPORTANT!** Conduit must be pitched down to allow condensation to drain away from motor. Conduit cannot turn up and must be watertight.
4. Towers with no ladder and handrail:
 - a. One cell towers may have disconnect switch located directly below motor.
 - b. Two cell towers should have disconnect switches located together. Separate conduit is required for each motor. Install conduit around perimeter of tower.
5. Towers with ladder and handrail:

Disconnect switches should be located on ladder side of tower for ease in accessibility. Separate conduit is required for each motor. Install conduit around perimeter of tower. See conduit installation key plan.

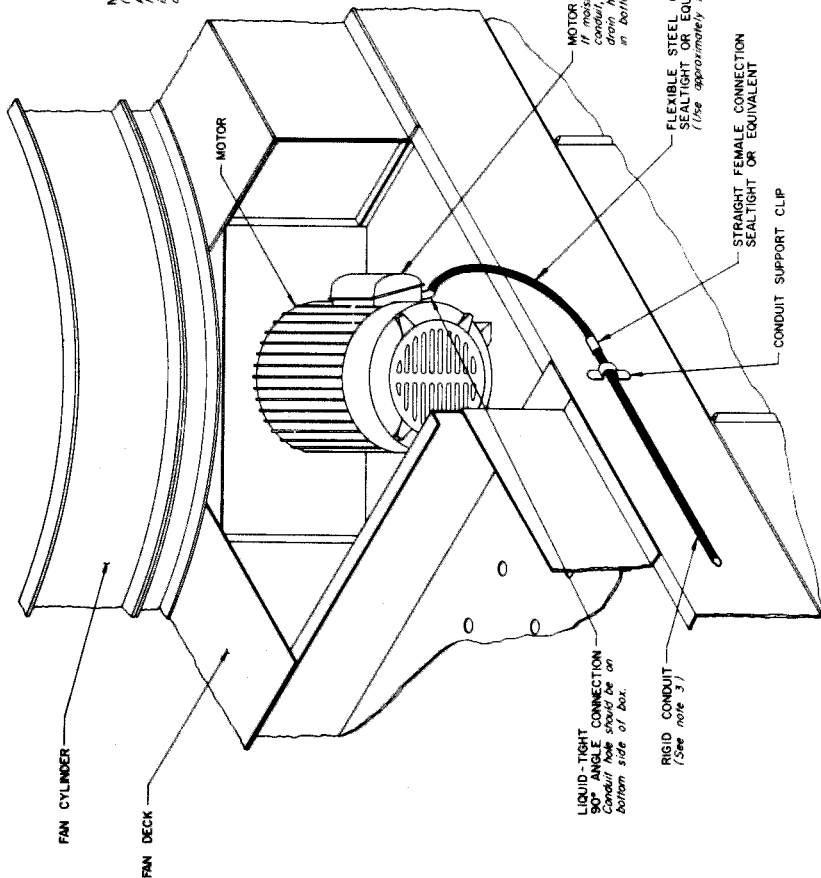

VIEW A-A

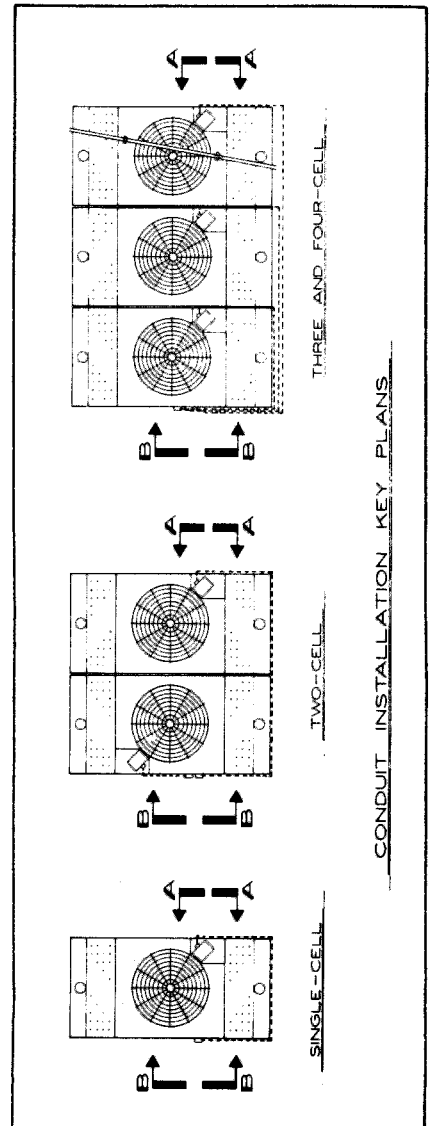

CONDUIT INSTALLATION KEY PLANS

8900 MODEL TOWERS

MOTOR RE-LUBRICATION INSTRUCTIONS

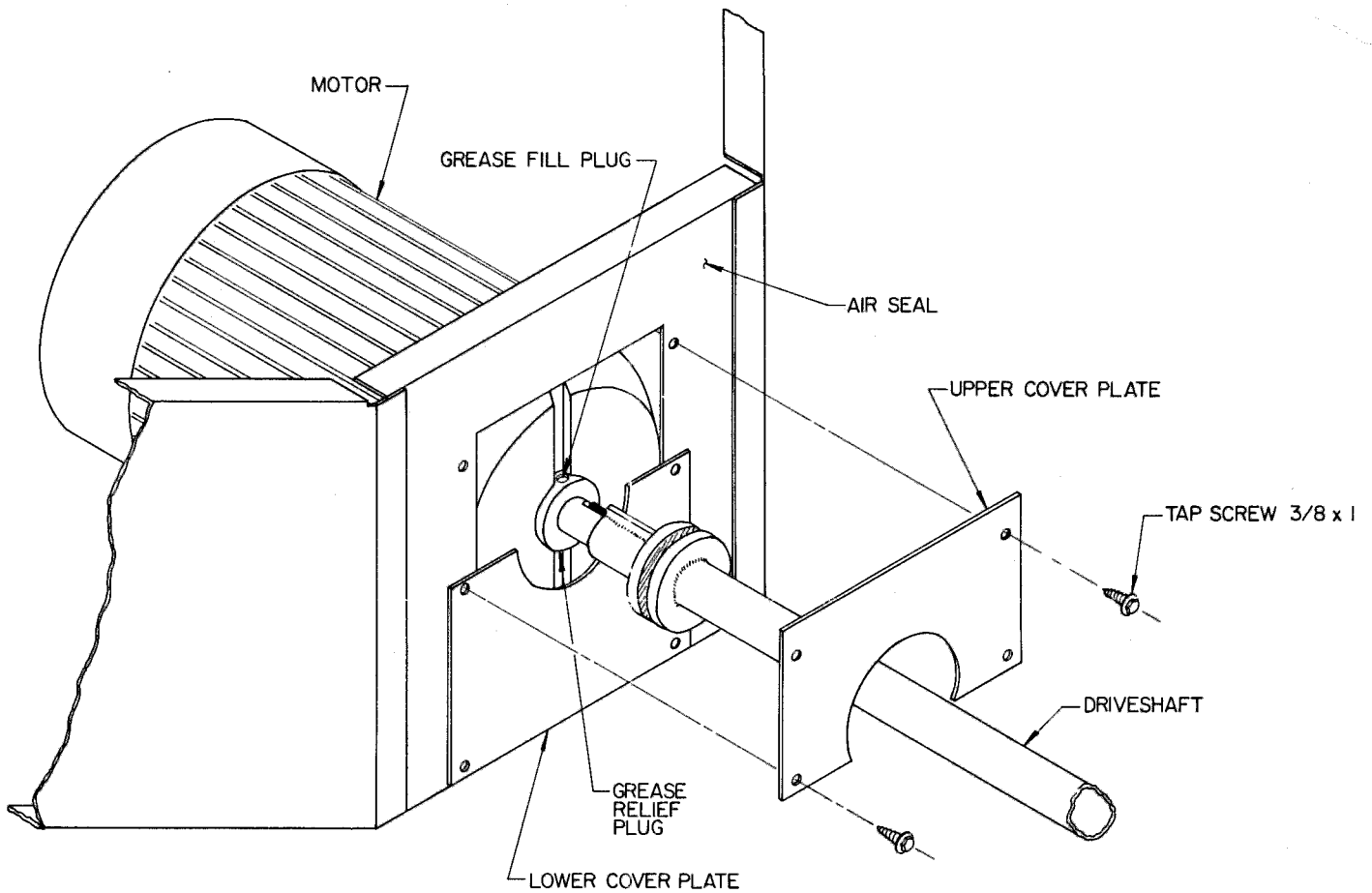

DETAIL "B"

Removal of cover plates from inside tower for access to shaft extension

CAUTION: *Open and tag out main power supply switch and make sure motor cannot be started.*

1. Remove cover plates as shown in Detail "B". Opposite end motor bearing is assessible from outside the tower.
2. Remove grease fill and relief plugs at both shaft extension end and opposite end bearings and remove hardened grease, using clean wire.
3. Insert grease fittings in grease fill openings and add grease until grease is forced out relief openings.
4. Replace fill plugs and operate mechanical equipment 30 minutes to one hour to purge excess grease at grease relief opening. *Shut down and tag out main power supply switch. Make sure motor cannot be started.*
5. Reinstall grease relief plugs and reinstall cover plates. See Detail "B".
6. Resume normal tower operation.

RECOMMENDED CONDUIT INSTALLATION FOR 8900 MODEL TOWERS

GENERAL NOTES

1. All conduit, connections, supporting clips, and safety switches are supplied by others.
2. All wiring must conform to local and national codes.
3. Conduit should be supported approximately every ten feet, except where noted. **IMPORTANT!** Conduit must be pitched down to allow condensation to drain away from motor. Conduit cannot turn up and must be watertight.
4. Towers with no ladder and handrail:
 - a. One cell towers may have disconnect switch located directly below motor.
 - b. Two cell towers should have disconnect switches located together. Separate conduit is required for each motor. Install conduit around perimeter of tower.
5. Towers with ladder and handrail:

Disconnect switches should be located on ladder side of tower for ease in accessibility. Separate conduit is required for each motor. Install conduit around perimeter of tower. See conduit installation key plan.

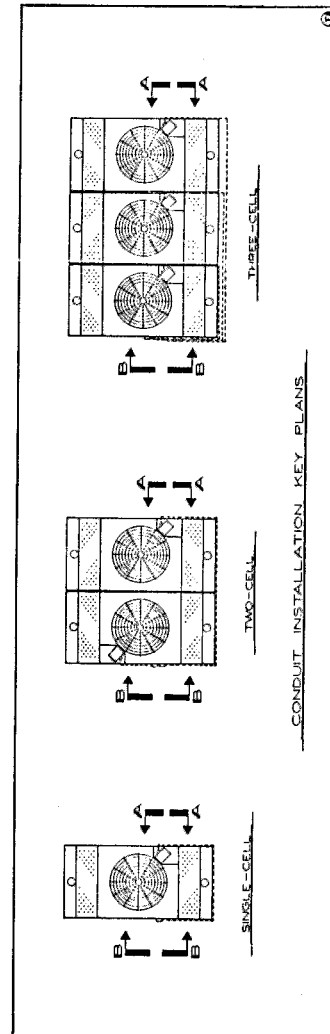
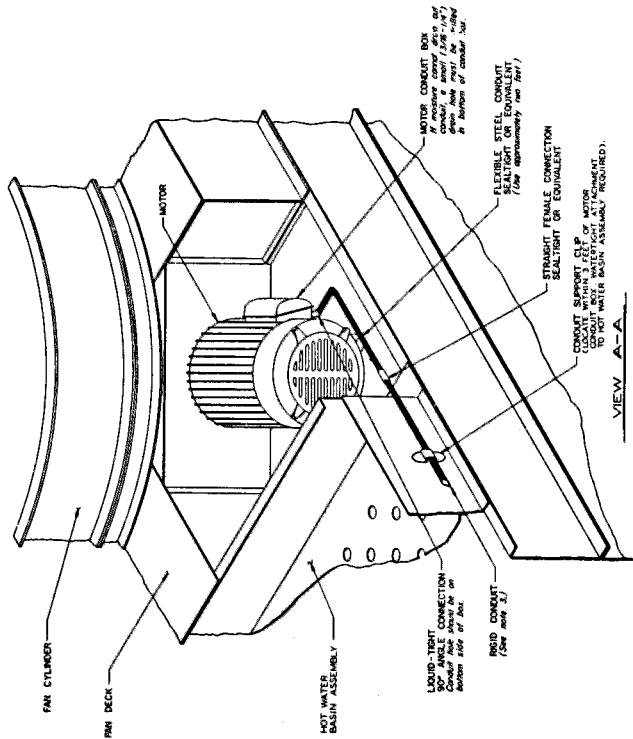
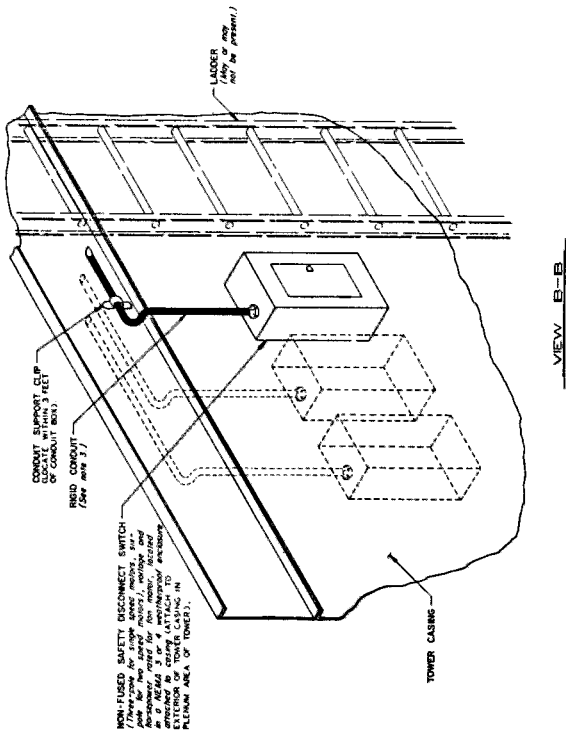

TOWER TROUBLE TIPS

TROUBLE	CAUSE	REMEDY
Motor Will Not Start	Power not available at motor terminals	<ol style="list-style-type: none"> 1. Check power at starter. Correct any bad connections between the control apparatus and the motor. 2. Check starter contacts and control circuit. Reset overloads, close contacts, reset tripped switches or replace failed control switches. 3. If power is not on all leads at starter make sure overload and short circuit devices are in proper condition.
	Wrong connections	Check motor and control connections against wiring diagrams.
	Low voltage	Check nameplate voltage against power supply. Check voltage at motor terminals.
	Open circuit in motor winding	Check stator windings for open circuits.
	Motor or fan drive stuck	Disconnect motor from load and check motor and Geareducer for cause of problem.
	Rotor defective	Look for broken bars and rings.
Unusual Motor Noise	Motor running single-phase	Stop motor and attempt to start it. Motor will not start if single-phased. Check wiring, controls and motor.
	Motor leads connected incorrectly	Check motor connections against wiring diagram on motor.
	Ball bearings	Check lubrication. Replace bad bearings.
	Electrical unbalance	Check voltage and currents of all three lines. Correct if required.
	Air gap not uniform	Check and correct bracket fits or bearing.
	Rotor unbalance	Rebalance.
	Cooling fan hitting end bell guard	Reinstall or replace fan.
Fan Noise	Blade rubbing inside of fan cylinder	Adjust cylinder to provide blade tip clearance.
	Loose bolts in blade clamps	Check and tighten if necessary. Check fan blade pitch. Refer to Fan Service Manual.
Scale or Foreign Substance in Water System	Lack of or insufficient bleed-off	See "Water Treatment" section of this manual.
	Water treatment	Consult competent water treating specialist. See "Water Treatment" section of this manual.
Unusual Fan Drive Vibration	Loose bolts and cap screws	Tighten all bolts and cap screws on all mechanical equipment and supports.
	Unbalanced drive shaft or worn couplings	Make sure motor and Geareducer shafts are in proper alignment and "match marks" properly matched. Repair or replace worn couplings. Rebalance drive shaft by adding or removing weights from balancing cap screws. See Drive Shaft Service Manual.
	Unbalanced Fan	Be sure blades are properly positioned in correct sockets. (See match numbers.) Make certain all blades are as far from center of fan as safety devices permit. All blades must be pitched the same. See Fan Service Manual. Clean off deposit build-up on blades.
	Worn Geareducer bearings	Check fan and pinion shaft endplay. Replace bearings as necessary.
	Unbalanced motor	Disconnect load and operate motor. If motor still vibrates, rebalance rotor.
	Bent Geareducer shaft	Check fan and pinion shafts with dial indicator. Replace if necessary.

TOWER TROUBLE TIPS (continued)

TROUBLE	CAUSE	REMEDY
Excessive Water Drift	Faulty drift elimination	<ol style="list-style-type: none"> 1. Check to be sure all louvers and eliminator sections are in place. (Towers with asbestos fill only.) 2. Metering orifices of hot water basins must be in place and clean of debris. 3. There must be no leaks under hot water basin sides.
	Overpumping	Reduce water flow to tower to design conditions or use larger basin orifices. Excess water flow will cause overflowing onto fan deck and into fan cylinder.
Cold Water Too Warm	Overpumping	Reduce water flow to tower to design conditions.
	Not enough air	Check motor current and voltage to be sure of correct contract horsepower. Clean louvers, fill and eliminators.
Motor Runs Hot	Motor overload, wrong voltage or unbalanced voltage	Check voltage and current of all three lines against nameplate values.
	Wrong motor rpm	Check nameplate against power supply. Check rpm of motor and gear ratio.
	Bearings overgreased	Remove grease reliefs. Run motor up to speed to purge excessive grease.
	Wrong lubricant in bearings	Change to proper lubricant. See motor manufacturer's instructions.
	One phase open	Stop motor and attempt to start it. Motor will not start if single-phased. Check wiring, controls and motor.
	Poor ventilation	Clean motor and check ventilation openings. Allow ample ventilation around motor.
	Winding fault	Check with Ohmmeter.
	Bent motor shaft	Straighten or replace shaft.
	Insufficient grease	Remove plugs and regrease bearings.
	Too frequent starting	Limit accumulative starting time to a total of 30 seconds each hour.
	Deterioration of or foreign material in grease	Flush bearings and relubricate.
	Bearings damaged	Replace bearings.
Motor Does Not Come Up To Speed	Voltage too low at motor terminals because of line drop	Check transformer and setting of taps. Use higher voltage on transformer terminals or reduce loads. Increase wire size or reduce inertia.
	Broken rotor bars	Look for cracks near the rings. A new rotor may be required. Have motor service man check motor.
Wrong Rotation (Motor)	Wrong sequence of phases	Change any two of the three motor leads.
Geareducer Noise	Geareducer bearings	If new, see if noise disappears after one week of operation. Drain, flush and refill Geareducer. See Geareducer Service Manual. If still noisy, replace.
	Gears	Correct tooth engagement. Replace badly worn gears. Replace gears with imperfect tooth spacing or form.