



DT-DTX Series unit cooler

INSTALLATION - OPERATION - MAINTENANCE

R0 E316013 ISSUED 02/2020

READ AND UNDERSTAND THIS MANUAL PRIOR TO OPERATING OR SERVICING THIS PRODUCT.



contents

1	Receipt Of Equipment	3
1.1	Inspection	3
1.2	Loss of Gas Holding Charge	3
2	Assembly Of Components	3
2.1	Shipped Loose Parts	3
2.2	Long Throw Adapter	3
2.3	Water Defrost Splash Guard	3
2.4	Dielectric Flange Union	3
3	Rigging Instructions	3
4	Unit Location And Mounting	3
4.1	Unit Location	3
4.2	Mounting	4
5	Refrigerant Warning	6
6	Piping Installation	6
6.1	Drain Line	6
6.2	Refrigeration Piping	7
6.3	Hot Gas Interpiping	8
6.4	Refrigerant Distributor Nozzle	8
6.5	Expansion Valve (optional item)	8
6.6	Evacuation and Leak Test	8
6.7	DXA and Suction Accumulators	9
7	Electrical	9
7.1	Field Wiring	9
7.2	Electrical Data	9
7.3	Suggested No Defrost Requirement Sequence of Operation	14
7.4	Suggested Air Defrost Sequence of Operation	14
7.5	Suggested Electric Defrost Sequence of Operation	14
7.6	Suggested Hot Gas Defrost Sequence of Operation	15
7.7	Suggested Water Defrost Sequence Of operation	15
8	Operation	16
8.1	Pre-Startup	16
8.2	Operation Checkout	16
9	Maintenance	17
9.1	Drain Pan	17
9.2	Coil and Cabinet	17
9.3	Fan Replacement	17
9.4	Motor Replacement	17
9.5	Fan Guard and Belly Band Replacement	17
9.6	Electric Defrost Heater Replacement	17
9.7	Water Defrost Distribution Pan Replacement	18
10	Replacement Parts List	18
11	Maintanance Data	20

receiving and installation

1 RECEIPT OF EQUIPMENT

1.1 INSPECTION

All equipment should be carefully checked for damage or shortages as soon as it is received. Each shipment should be carefully checked against the bill of lading. If optional Long Throw Adapters have been ordered, the adapters are shipped loose from the evaporator. If any damage or shortage is evident, a notation must be made on the delivery receipt before it is signed and a claim should then be filed against the freight carrier. Inspection and claims are the responsibility of the recipient.

1.2 LOSS OF GAS HOLDING CHARGE

Each copper, steel, and stainless steel tube DT/DTX unit is leak tested, evacuated to remove moisture and then shipped with a gas holding charge. Absence of this charge may indicate a leak has developed in transit. The system should not be charged with refrigerant until it is verified that there is no leak, or the source of the leak is located. If the unit contains aluminum tubes or flanged refrigerant connections, the unit is leak tested and evacuated but a gas holding charge is not provided.

2 ASSEMBLY OF COMPONENTS

2.1 SHIPPED LOOSE PARTS

Long Throw Adapters, Water Defrost Splash Guards with required bolts and nuts and Dielectric Flange Union with required bolts, nuts, and gaskets (if the coil contains aluminum tubes) supply shipped loose. See Figure 1 for Long Throw Adapters and Water Defrost.

2.2 LONG THROW ADAPTER

Long Throw Adapters should be mounted on the unit before the unit is installed. The evaporator fan cabinet contains through-bolts with the threaded end pointing out away from the fan cabinet. The bolts have two 1/2" nuts and flat washers on them. Remove the outer most nut and flat washer on each bolt. Keep the fan guard in place and put the Long Throw Adapter on the bolts braced against the fan guard. While holding the adapter with one hand place the flat washers on the bolts, then thread the nuts on the top two bolts first to hold the guard and adapter in place. Then place the remaining washers and thread the remaining two nuts on the bottom two bolts. Secure with a wrench.

2.3 WATER DEFROST SPLASH GUARD

When the water defrost splashguard is shipped loose, align the holes in the guard to the holes on the bottom horizontal support angle on the air inlet side of the evaporator. Use the bolts and nuts provided with the splashguard to hold it in place.

2.4 DIELECTRIC FLANGE UNION

Aluminum tube evaporators have aluminum flanged refrigerant connections. A dielectric flange union to attach steel pipe to the aluminum evaporator flange is provided in a separate box. The box should contain dielectric bolt gaskets, bolts, nuts, flange gasket, and mating steel socket weld flange. To avoid material damage during assembly, preweld a length of refrigerant pipe to the steel flange before assembly to the aluminum flange. See Section 6.2 for the aluminum to steel flange assembly drawing.

3 RIGGING INSTRUCTIONS

A DT/DTX unit tends to be a long and heavy object with about 2/3 of the weight contained in the coil element at the rear of the unit. Jobsite requirements will affect the method of moving and lifting the unit into place. Carefully consider the support that is required to lift and move the unit. Under no circumstances should the shipping skid be used for lifting the unit. To ensure that the unit is not bowed or damaged when being lifted into place from above, all leg or hanger points should be used. If the unit is being lifted into place from underneath, a level support directly under all of the shipping legs is required to adequately steady the unit as it is lifted to the hanger rods.

4 UNIT LOCATION AND MOUNTING

4.1 UNIT LOCATION

Unit must be located to provide good air circulation to all areas. The unit should be positioned to blow away from walls and directed down an aisle, over product, or into product as the room design is specified. For best performance it is desirable to arrange the air discharge toward the door of the room to minimize the entrance of warm moist air when the door is open. If the distance between the unit and a dock door is within the longest third of the unit standard air throw distance, long throw adapters should be considered to keep air velocity up in the door area. Light fixtures, shelving, ceiling structures, and product boxes must be located so that they do not block the air intake or air discharge from the unit.

IMPORTANT—The coil face must be located away from a wall a minimum distance equal to the height of the coil to assure unrestricted air intake.

On all electric defrost units a space at the ends of the unit should be provided for the possible future replacement of the electric defrost heaters. Figure 2 specifies the recommended access dimensions that are needed to remove the heater rods on one or both ends of the unit.



receiving and installation

4.2 MOUNTING

The DT/DTX units should be suspended with 1/2" diameter threaded steel hanger rods. Do not use nylon-threaded rods. Rods should have double nuts on the top and bottom. Adequate support must be provided to hold the weight of the unit. Refer to the unit drawing supplied with the unit or the catalog for the approximate unit weight and hanger locations. All hanger holes should be used to support the unit. Do not temporarily support a unit using less than all hanger or shipping leg holes. The shipping support legs can

be removed after the unit is hung. See unit drawing for mounting hole locations. If the refrigeration system is direct expansion, the distributor orifice and expansion valve should be in place before the unit is hung. See Sections 6.4 and 6.5.

The unit must be level in all directions to insure proper drainage of the condensate drain pan. Suspended units must have sufficient clearance above for cleaning the top of the unit and repairing the Water Defrost assemblies, if provided.

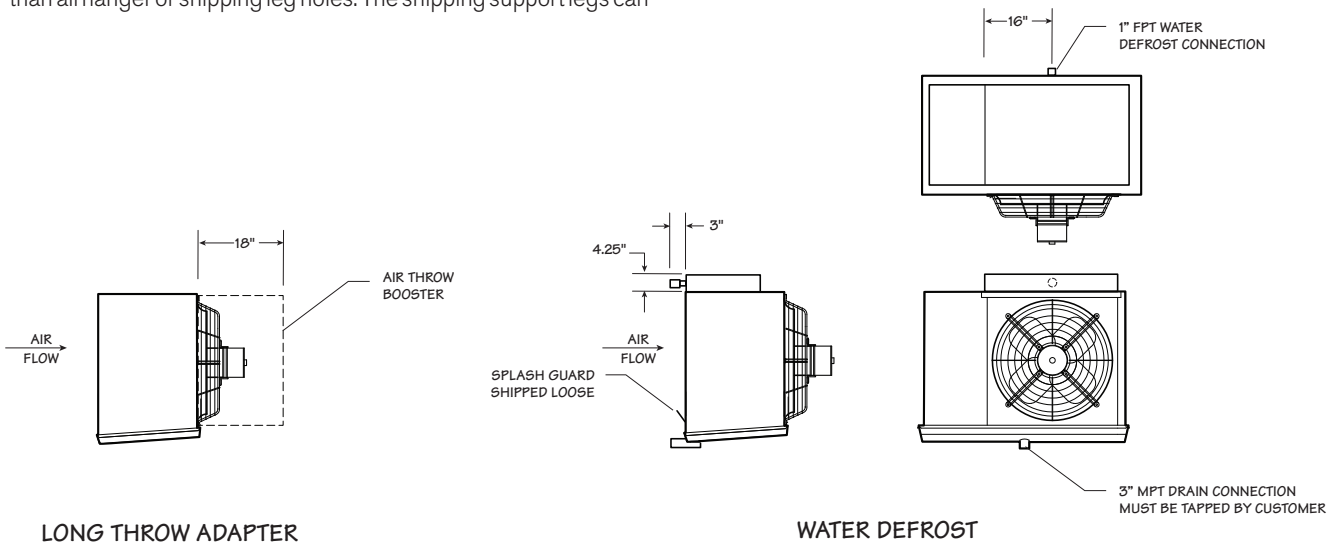

FIGURE 1 Shipped Loose Parts

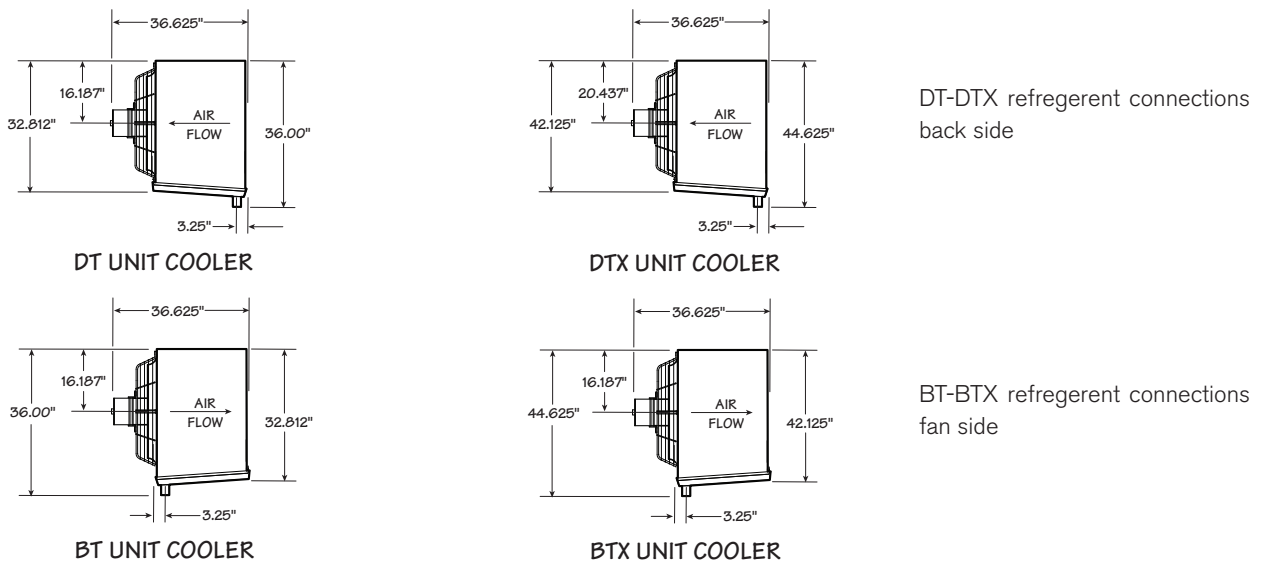

FIGURE 2A Unit Dimension

installation

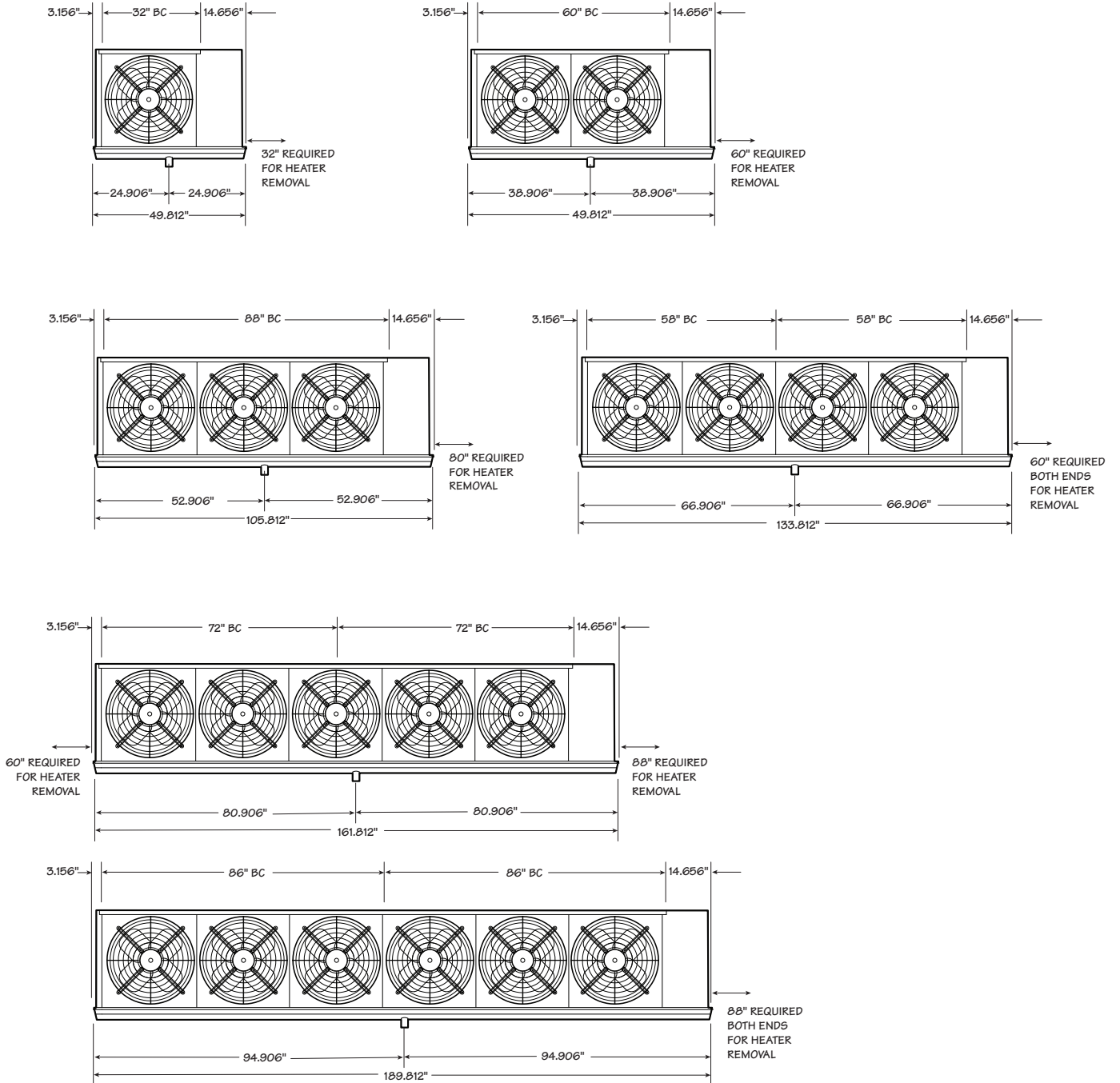

FIGURE 2B Unit Dimension

installation

5 REFRIGERANT WARNING

The use of any refrigerant can be dangerous under certain conditions. Where people or product can be exposed to hazardous conditions, daily inspections should be made for the detection of any defect or malfunction that could cause the escape of the refrigerant and cause harm. In the case of halocarbon refrigerants, electronic detection devices are available for sensing the presence of such refrigerants in the atmosphere.

Ammonia is a "self-alarmed" gas with its strong odor but detection devices are strongly recommended. People and product are a concern based on the concentration levels (ppm) of ammonia along with OSHA and EPA regulations. An ammonia gas detection device connected to an external alarm system to warn that a leak is occurring is recommended. Refer to local codes and Fire Department for additional local regulations.

Only experienced, qualified personnel should install, operate, and maintain detection and alarm equipment.

6 PIPING INSTALLATION

6.1 DRAIN LINE

The drain line should be as short and as steeply pitched as possible with a minimum of 1/4" drop per running foot. The drain line should

be the same size, or larger, as the drain pan connection. A drain line trap should be installed to prevent warm moist air from migrating through the drain line. The trap should be located in the warmest and/or lowest section of the piping to avoid freezing and provide sufficient liquid head for flow through the trap. If the temperature surrounding the drain line is below freezing (32°F) it must be wrapped with a drain line heater and insulation. Be sure to also wrap the drain pan coupling. The drain line heater should be energized continuously, but to avoid the possibility of overheating, heat tape manufacturers recommend a thermostat be installed. Be sure to follow the manufacturer's recommendations. The drain line trap should be outside of the freezing space. See Figure 3.

A union at the drain pan connection is recommended for future servicing. The union should be located just outside the edge of the drain pan so that when the pan is lowered for cleaning or repair the drain line run is not in the way. Use two wrenches when tightening to prevent the drain fitting from twisting and damaging the drain pan. See Figure 4.

Long runs of drain line, i.e. more than a few feet, should be supported by hangers to avoid damage to the drain pan. For cleaning and inspecting the drain, tees with plugs are recommended instead of elbows.

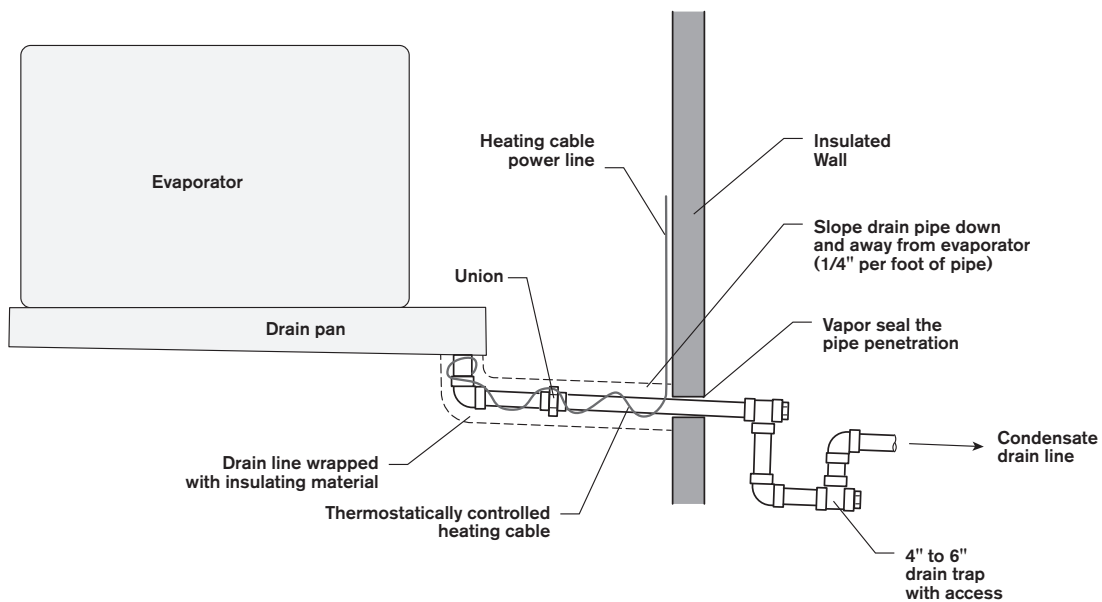

FIGURE 3 Drain Line

installation

6.2 REFRIGERATION PIPING

Installation design must conform to all local and national codes, laws and regulations applying to the site of installation. In addition, safety codes for mechanical refrigeration, IIR-2, ANSI/ASHRAE Std. 15, and ASME B31.5, should be followed as a guide to safe installation and operation practice.

Refrigerant line sizes, piping support, and piping techniques should be obtained from published recognized refrigeration standards. Under no circumstances should the refrigerant connection size of the unit be used as the basis for sizing the lines.

For aluminum flange union connections see Figure 5 for final assembly drawing.

IMPORTANT—The DT/DTX units have not been designed to carry the weight of any external piping or valves. Improper support of external piping and valves may result in unit breakage and refrigerant leakage.

The horizontal suction line should slope away from the unit. Vertical suction risers on halocarbon systems require a properly sized “P” trap at the foot of the riser for proper oil return, and thermostatic expansion valve operation.

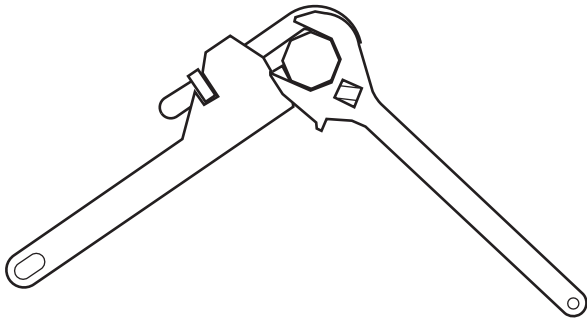

FIGURE 4 Pipe Joining

installation

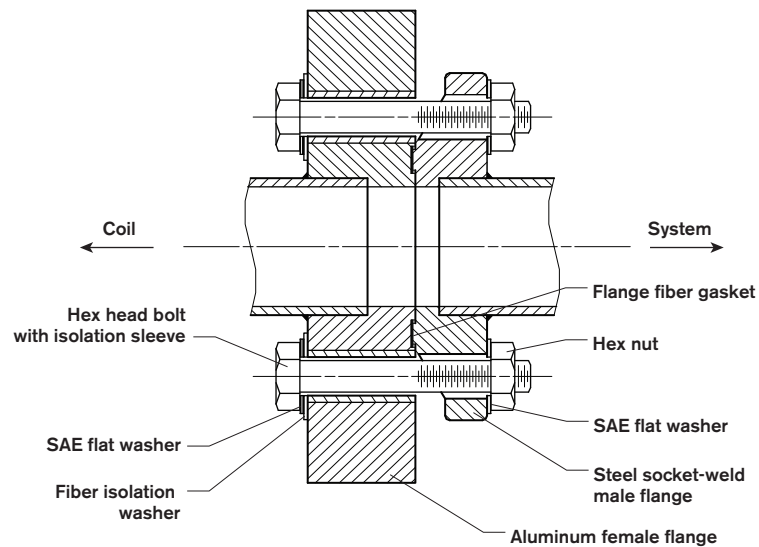

FIGURE 5 Aluminum Flange Assembly

6.3 HOT GAS INTERPIPING

If the unit was ordered with hot gas defrost the drawing shipped with the unit will contain the piping connection locations for the hot gas inlet and the condensate relief.

6.4 REFRIGERANT DISTRIBUTOR NOZZLE

For a direct expansion system, the DT/DTX Series units already have the distributor nozzle installed. As a check, see that the nozzle is in the distributor, or the auxiliary hot gas tee for direct expansion halocarbon with hot gas defrosts, before installing the thermal expansion valve to the distributor or auxiliary hot gas tee.

6.5 EXPANSION VALVE (Optional Item)

Before hanging a unit with a direct expansion design, install the expansion valve and connect the equalizer tube. The expansion valve should be installed **directly** to the distributor body or as close as possible with **no elbows or bends**. Steel expansion valves for ammonia requires the removal of the discharge tube. Locate the expansion valve bulb on a horizontal length of suction line as close to the suction header as possible. Position the bulb in a 3, 4, 8, or 9 o'clock position. Do not position the bulb on the top or the bottom of the pipe. Clamp the bulb down flush and tight against the pipe and insulate. Never locate the bulb on a trap or downstream from a trap.

Expansion valves are NOT adjusted at the factory prior to shipment. It is important that the operation of the expansion valve be checked after the system has balanced out at the desired room temperature. If the coil is being starved it is necessary to reduce the superheat setting of the valve by turning the adjusting stem counter-clockwise. If the superheat is too low it is necessary to increase the superheat setting of the valve by turning the adjusting stem clockwise. It is recommended that for a 10°F to 12°F T.D. system, the valve be adjusted to maintain 5°F to 6°F of superheat.

6.6 EVACUATION AND LEAK TEST

When all refrigeration connections have been completed, the entire system must be tested for leaks and then evacuated.

installation

6.7 DXA AND SUCTION ACCUMULATORS

Do not use units with Direct Expansion Ammonia (DXA) feed below 0°F evaporating temperatures unless the compressor system is designed and protected to handle the overfed liquid by use of a suction accumulator.

7 ELECTRICAL

FOR SAFETY BEFORE SERVICING:

If the DT/DTX Series unit is equipped with an electrical power disconnect switch make sure the switch is in the "OFF" position before working on the unit, preferably locked out in this position.

7.1 FIELD WIRING

Field wiring should comply with NEC and local codes. The power supply voltage, phase and frequency must match what is shown on the unit data plate. Wiring should be made so that the fan rotation is counter-clockwise. A motor in a cold room may draw greater than nameplate amperage due to denser, colder air flowing through the unit.

Wiring for a unit with Air, Hot Gas, or Water Defrost, without a SGS mounted electrical panel, requires power to the fan motor disconnect switch only. The fan motor disconnect is located on the front panel at the refrigerant connection end of the unit. If the unit is supplied with Electric Defrost, but no control panel, wiring will be required to the mounted terminal blocks in the electrical enclosure for defrost heaters. See **Figure 5, 6, 7, 8** for typical unit wiring with. If a SGS mounted control panel is provided, wiring to only one set of terminal blocks is required. See wiring diagram supplied with unit.

7.2 ELECTRICAL DATA

Table 1 – Motor Electrical Data								
Unit	Number of Fans	hp	Fan Motor Nameplate Total Full Load Amps					
			115/1	208/1 230/1	208/3 230/3	460/3	380/3	575/3
DT1 - DTX1	1	1/3	5.40	2.70	1.70	0.85	0.55	
BT1 - BTX1	1	1/2	7.80	3.90	2.00	1.00	1.10	0.76
DT2 - DTX2	2	1/3	10.80	5.40	3.40	1.70	1.10	
BT2 - BTX2	2	1/2	15.60	7.80	4.00	2.00	2.20	1.52
DT3 - DTX3	3	1/3	16.20	8.10	5.10	2.55	1.65	
BT3 - BTX3	3	1/2		11.70	6.00	3.00	3.30	2.28
DT4 - DTX4	4	1/3		10.80	6.80	3.40	2.20	
BT4 - BTX4	4	1/2			8.00	4.00	4.40	3.04
DT5 - DTX5	5	1/3		13.50	8.50	4.25	2.75	
BT5 - BTX5	5	1/2			10.00	5.00	5.50	3.80
DT6 - DTX6	6	1/3			10.20	5.10	3.30	
BT6 - BTX6	6	1/2			12.00	6.00	6.60	4.56

installation

Table 2 – Reheat Electrical Data						
Unit*	Heater Quantity one/fan	kW	Reheat Heater Total Full Load Amps			
			208/3 230/3	460/3	380/3	575/3
DT1 - DTX1 BT1 - BTX1	1	4.65	11.67	5.84	7.06	4.67
DT2 - DTX2 BT2 - BTX2	2	9.30	23.35	11.67	14.13	9.34
DT3 - DTX3 BT3 - BTX3	3	13.95	35.02	17.51	21.19	14.01
DT4 - DTX4 BT4 - BTX4	4	18.60	46.69	23.35	28.26	18.68
DT5 - DTX5 BT5 - BTX5	5	23.25	58.36	29.18	35.32	23.35
DT6 - DTX6 BT6 - BTX6	6	27.90	70.04	35.02	42.39	28.01

*Reheat used with 6 row units only

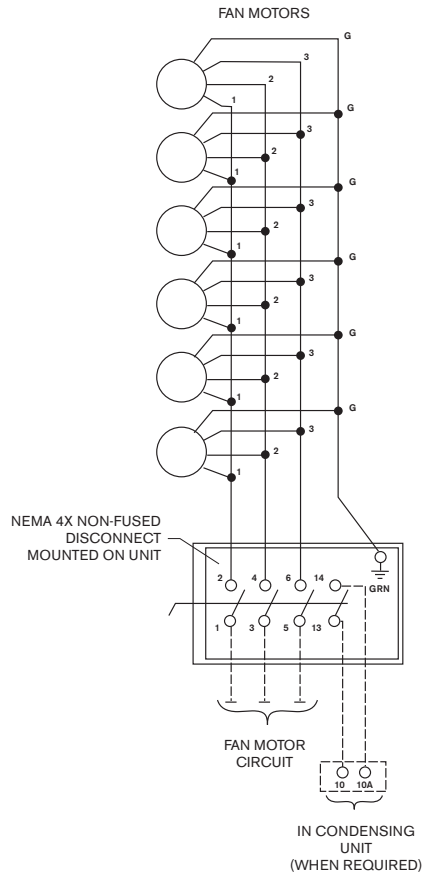

FIGURE 6 Air Defrost Wiring 230/380/460/575/3/60

installation

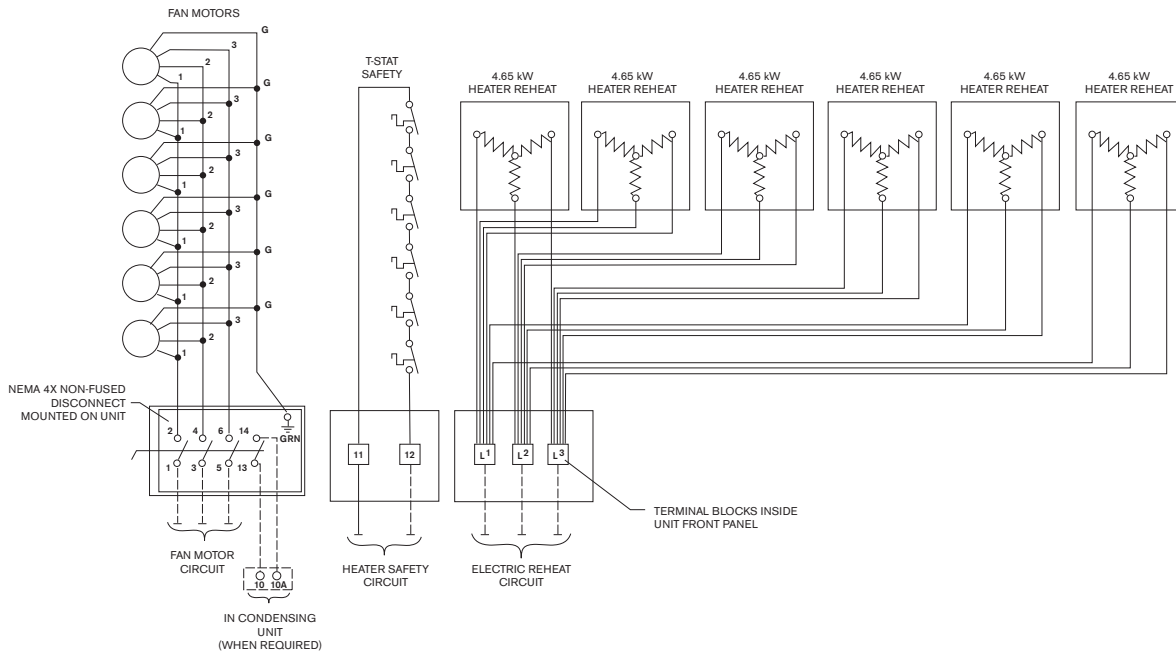

FIGURE 7 Electric Defrost Wiring 230/460/575/3/60

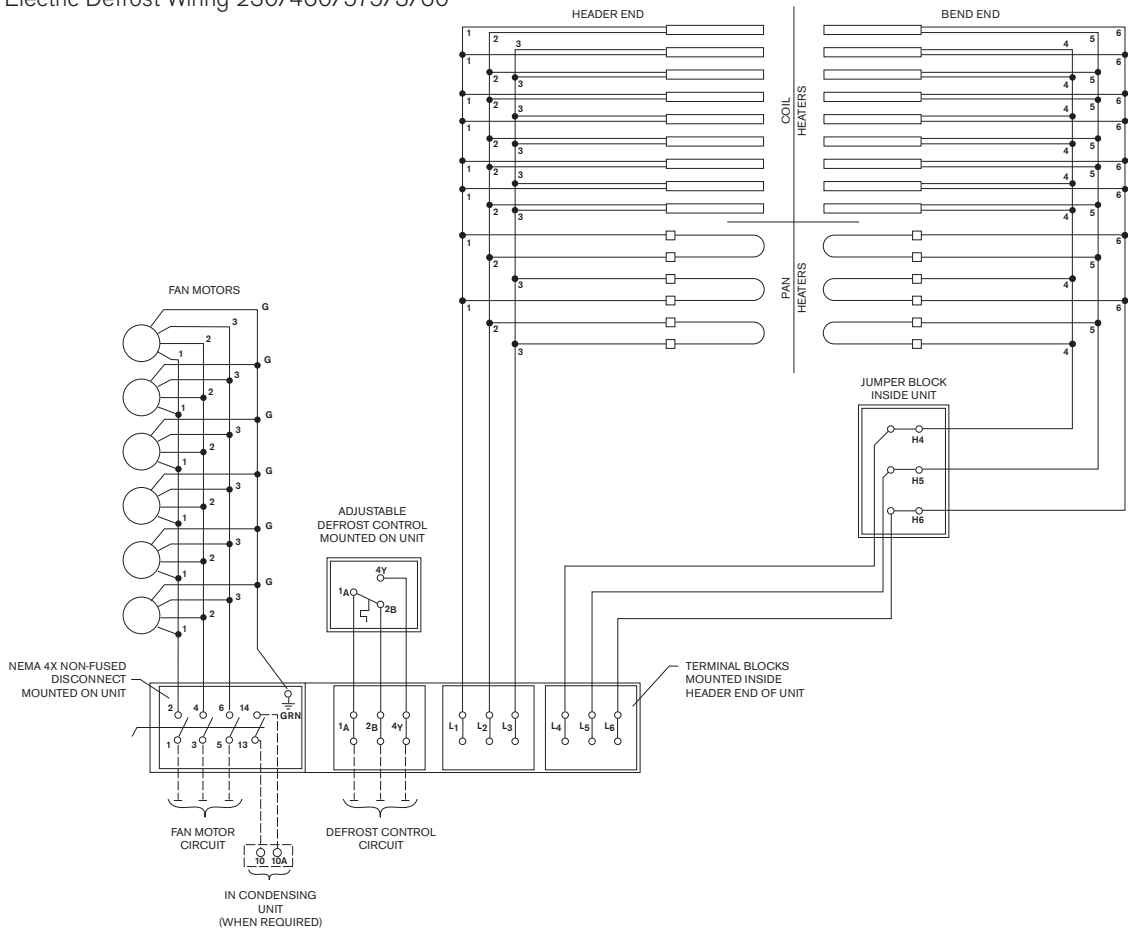

FIGURE 8 Electric Defrost Wiring 230/3/60

installation

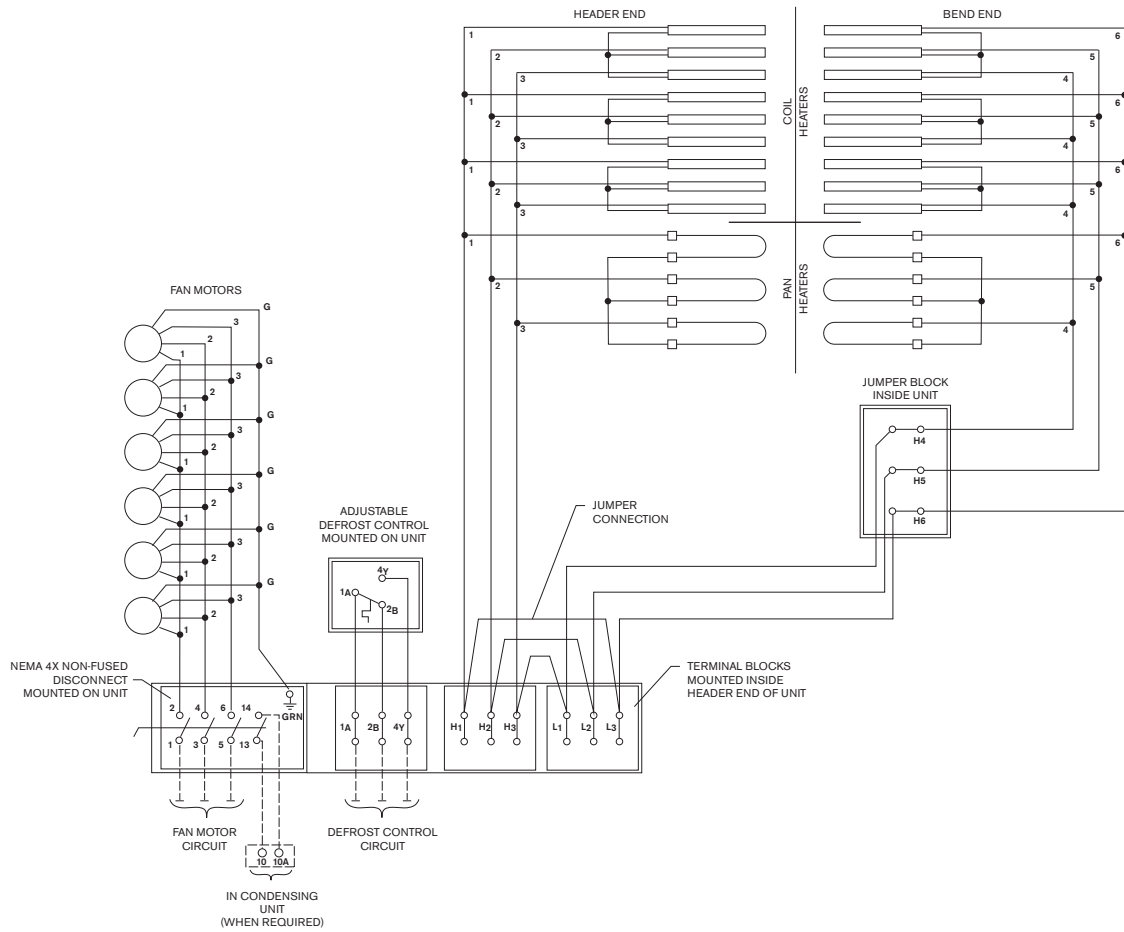

FIGURE 9 Electric Defrost Wiring 460/575/3/60

installation

Table 3 – Electric Defrost Data

Model	Rows	ED						EDL					
		Total Heaters	Number of Circuits Amps per Circuit			Total Heaters	Number of Circuits Amps per Circuit			Total Heaters	Number of Circuits Amps per Circuit		
		kW	230V/3	460V/3	575V/3	kW	380V/3	kW	230V/3	460V/3	575V/3	kW	380V/3
DT/BT 1	6	3.0	1 x 7.5	1 x 3.8	1 x 3.0	2.7	1 x 4.1	5.4	1 x 13.6	1 x 6.8	1 x 5.4	4.9	1 x 7.5
DT 1	8	4.5	1 x 11.3	1 x 5.6	1 x 4.5	4.1	1 x 6.2	6.9	1 x 17.3	1 x 8.7	1 x 6.9	6.3	1 x 9.5
DT/BT 2	6	6.0	1 x 15.1	1 x 7.5	1 x 6.0	5.5	1 x 8.3	10.4	1 x 26.2	1 x 13.1	1 x 10.5	9.5	1 x 14.4
DT 2	8	9.0	1 x 22.6	1 x 11.3	1 x 9.0	8.2	1 x 12.4	13.4	1 x 33.7	1 x 16.9	1 x 13.5	12.2	1 x 18.6
DT/BT 3	6	9.0	1 x 22.6	1 x 11.3	1 x 9.0	8.2	1 x 12.4	15.4	1 x 38.8	1 x 19.4	1 x 15.5	14.1	1 x 21.4
DT 3	8	13.5	1 x 33.9	1 x 16.9	1 x 13.6	12.3	1 x 18.7	19.9	1 x 33.9	1 x 25.0	1 x 20.0	18.1	1 x 27.6
										1 x 16.2			
DT/BT 4	6	12.0	1 x 30.1	1 x 15.1	1 x 12.0	10.9	1 x 16.6	20.5	1 x 25.7	1 x 25.7	1 x 20.5	18.6	1 x 28.3
DT 4	8	18.0	1 x 45.2	1 x 22.6	1 x 18.1	16.4	1 x 24.9	26.5	1 x 33.2	1 x 33.2	1 x 26.6	24.1	1 x 36.6
DT/BT 5	6	15.0	1 x 37.7	1 x 18.8	1 x 15.1	13.6	1 x 20.7	25.5	1 x 37.6	1 x 32.0	1 x 25.6	23.2	1 x 35.2
										1 x 26.3			
DT 5	8	22.5	1 x 33.9	1 x 28.2	1 x 22.6	20.5	1 x 31.1	33.0	1 x 33.9	1 x 41.4	1 x 33.1	30.0	1 x 45.6
			1 x 22.6							1 x 15.0			
DT/BT 6	6	18.0	1 x 45.2	1 x 22.6	1 x 18.1	16.4	1 x 24.9	30.5	1 x 38.3	1 x 38.3	1 x 30.6	27.8	1 x 42.2
DT 6	8	27.0	1 x 33.9	1 x 33.9	1 x 27.1	24.6	1 x 37.3	39.5	1 x 33.9	1 x 24.8	1 x 39.7	35.9	1 x 27.3
										1 x 31.4			
DTX/BTX 1	6	4.5	1 x 11.3	1 x 5.6	1 x 4.5	4.1	1 x 6.2	6.9	1 x 17.3	1 x 8.7	1 x 6.9	6.3	1 x 9.5
DTX 1	8	6.0	1 x 15.1	1 x 7.5	1 x 6.0	5.5	1 x 8.3	8.4	1 x 21.1	1 x 10.5	1 x 8.4	7.6	1 x 11.6
DTX/BTX 2	6	9.0	1 x 22.6	1 x 11.3	1 x 9.0	8.2	1 x 12.4	13.4	1 x 33.7	1 x 16.7	1 x 13.5	12.2	1 x 18.6
DTX 2	8	12.0	1 x 30.1	1 x 15.1	1 x 12.0	10.9	1 x 16.6	16.4	1 x 41.2	1 x 20.6	1 x 16.5	14.9	1 x 22.7
DTX/BTX 3	6	13.5	1 x 33.9	1 x 16.9	1 x 13.6	12.3	1 x 18.7	19.9	1 x 33.9	1 x 25.0	1 x 20.0	18.1	1 x 27.6
										1 x 16.2			
DTX 3	8	18.0	1 x 45.2	1 x 22.6	1 x 18.1	16.4	1 x 24.9	24.4	1 x 33.9	1 x 30.7	1 x 24.5	22.2	1 x 33.8
										1 x 27.5			
DTX/BTX 4	6	18.0	1 x 45.2	1 x 22.6	1 x 18.1	16.4	1 x 24.9	26.5	2 x 33.2	1 x 33.2	1 x 26.6	24.1	1 x 36.6
DTX 4	8	24.0	1 x 30.1	1 x 30.1	1 x 24.1	21.8	1 x 33.2	32.5	2 x 40.7	1 x 40.7	1 x 32.6	29.5	1 x 44.9
DTX/BTX 5	6	22.5	1 x 33.9	1 x 28.2	1 x 22.6	20.5	1 x 31.1	33.0	2 x 33.9	1 x 41.4	1 x 33.1	30.0	1 x 45.6
			1 x 22.6							1 x 15.1			
DTX 5	8	30.0	1 x 45.2	1 x 37.7	1 x 30.1	27.3	1 x 41.5	40.5	1 x 33.9	1 x 30.1	1 x 40.7	36.8	1 x 33.2
			1 x 30.1							1 x 26.3	1 x 20.7		1 x 22.8
										1 x 41.4			
DTX/BTX 6	6	27.0	2 x 33.9	1 x 33.9	1 x 27.1	24.6	1 x 37.3	39.5	2 x 33.9	2 x 24.8	1 x 39.7	35.9	2 x 27.3
										1 x 31.4			
DTX 6	8	36.0	2 x 45.2	1 x 45.2	1 x 36.1	32.8	1 x 24.9	48.5	2 x 45.2	2 x 30.4	2 x 24.4	44.1	2 x 33.5
										1 x 31.4			

installation

7.3 SUGGESTED NO DEFROST REQUIREMENT SEQUENCE OF OPERATION

Used for units with a suction temperature above freezing.

- A. When the room thermostat calls for cooling the liquid solenoid valve opens allowing refrigerant begins to flow to the unit.
- B. When the thermostat is satisfied the liquid solenoid valve closes, which stops refrigerant flowing to the unit.
- C. The fan motors continue to run throughout the cycle.

7.4 SUGGESTED AIR DEFROST SEQUENCE OF OPERATION

Used for units with a suction temperature below freezing, but a room temperature above 36°F.

- A. A defrost timer is wired into the fan motors control.
- B. The timer turns off the liquid line solenoid valve at a predetermined time, but the fan motors continue to operate.
- C. When the refrigerant is completely boiled out of the unit, the fan motors still continue to operate so that the room air temperature melts the coil frost.
- D. At a second predetermined time, the timer energizes the liquid solenoid valve and refrigeration resumes.

The timer settings are to be programmed per the need of each evaporator.

7.5 SUGGESTED ELECTRIC DEFROST SEQUENCE OF OPERATION

Used for units with a suction temperature below freezing. The Electric Defrost cycle is time clock initiated and temperature terminated. Three or four defrost cycles per 24 hour period are typical. The following sequence is based on the Paragon 8145 or equal time clock.

- A. Power is supplied to the defrost timer.
- B. The defrost termination thermostat is off and the defrost heaters are off.
- C. The unit operates in cooling mode.
- D. Upon initiation of the defrost cycle the time clock turns off the liquid line solenoid valve.
- E. After a site determined time period the timer de-energizes the fan motors and energizes the defrost heaters.
- F. The heaters, positioned within the coil turbo spacers in the fin pack, heat up the fins directly to melt the accumulated frost.
- G. When the coil reaches the temperature setting of the defrost termination thermostat the thermostat opens the defrost circuit to cut off power to the heaters.
- H. The defrost timer energizes the liquid line solenoid valve allowing refrigerant to flow into the unit, cooling the coil and refreezing any remaining condensate drops that are still present.
- I. The fan motor is started through the fan delay thermostat temperature setting, putting the unit in the cooling cycle.

The timer settings and the adjustable defrost termination fan delay thermostat settings are to be programmed per the need of each evaporator.

installation

7.6 SUGGESTED HOT GAS DEFROST SEQUENCE OF OPERATION

Used for units with a suction temperature below freezing. The Hot Gas Defrost cycle is time clock initiated and terminated. The following sequence is based on the Hansen Frost Master or equal time clock.

- A. Power is supplied to the defrost timer.
- B. The unit operates in the cooling cycle.
- C. Upon initiation of the defrost cycle, the defrost time clock turns off the liquid line solenoid valve. The fan motor(s) continues to operate to boil off the remaining refrigerant in the coil tubes.
- D. After a predetermined time period the defrost timer de-energizes the fan motor(s) and energizes the hot gas supply solenoid valve. Note that larger units may also have a "soft defrost" solenoid to slowly pressurize the coil, which will open before the main hot gas supply solenoid.
- E. Hot gas flows into the unit and warms up the tubes and fins (and drain pan if an HGU unit), melting the accumulated frost.
- F. Approximately eight to twelve minutes after starting the hot gas defrost cycle the defrost time clock should de-energize the hot gas supply solenoid valve. If the unit is in defrost for a much longer period of time the condensate on the tubes and fins could "steam" and refreeze on the fan cabinet, fan(s), or venturi causing maintenance problems.
- G. The defrost time clock should energize the vent solenoid, allowing any remaining high pressure gas to escape the coil.
- H. The defrost timer energizes the liquid line and suction line solenoid valves allowing refrigerant to flow into the unit, cooling the coil and refreezing any remaining condensate drops that are still present.
- I. The fan motor is energized after a preset fan delay in the time clock and the unit is in the cooling cycle.

The timer settings are to be programmed per the need of each evaporator.

7.7 SUGGESTED WATER DEFROST SEQUENCE OF OPERATION

Used for units with a suction temperature below freezing. The Water Defrost cycle is time clock initiated and terminated.

- A. Power is supplied to the defrost timer.
- B. The unit operates in the cooling cycle.
- C. Upon initiation of the defrost cycle, the defrost time clock turns off the liquid line solenoid valve. The fan motor(s) continues to operate to boil off the remaining refrigerant in the coil tubes.
- D. After a predetermined time period the defrost timer de-energizes the fan motor(s) and energizes the water supply solenoid valve.
- E. Water flows onto the unit and warms up the tubes, fins, and drain pan, melting the accumulated frost.
- F. Approximately ten minutes after starting the water defrost cycle the defrost time clock should de-energize the water supply solenoid valve.
- G. The defrost time clock should allow the remaining water to drip off of the coil surface.
- H. The defrost timer energizes the liquid line solenoid valve allowing refrigerant to flow into the unit, cooling the coil and refreezing any remaining condensate drops that are still present.
- I. The fan motor is energized after a preset fan delay in the time clock and the unit is in the cooling cycle.

The timer settings are to be programmed per the need of each evaporator.

operation

8.0 OPERATION

8.1 PRE-START UP

After the installation is completed, a review of the following items should be preformed before the system is placed into operation:

- A. Check electrical connections, fan bushing set screws, motor mount bolts, coil flange bolts, drain pan flange bolts, and all other fasteners for tightness. If required, be sure the thermostatic expansion valve bulb is properly located, strapped, and insulated.
- B. For systems with a defrost time clock check the timer to see that it is set for the correct time of day and the starting pins have been installed (normally two or three sets per day). Defrost should be scheduled when the freezer doors are not likely to be open.
- C. When the unit is first started the room temperature is typically above the contact closing temperature of the fan delay thermostat, if a fan delay thermostat is provided for Electric Defrost units (see that particular units electrical diagram). The fans may remain off for a lengthy period of time. To prevent this delay it is permissible to install a temporary jumper wire between terminals "1R" and "2B". Once the room temperature is below 25°F the jumper wire should be removed.
- D. The motors for either DT/DTX units are greased from the motor manufacturer.

8.2 OPERATION CHECKOUT

With the system operating, check the supply voltage. The voltage must be within +/- 10% of the voltage marked on the unit nameplate and the phase to phase unbalance should be 2% or less.

LISTEN CAREFULLY to the unit to make sure there are no unusual sounds. Sounds such as a noisy motor, the fan(s) scraping on the housing, or loose fasteners allowing parts to rattle need to be addressed immediately before continued unit operation.

Check the room **THERMOSTAT** setting. Be sure it functions properly.

For **RECIRCULATED** refrigeration systems the hand expansion valve should be opened slowly until either condensate or frost forms on the return bends from the bottom to the top of the coil. A good indicator is when the defrost relief valve reads 5 PSI above suction pressure.

For **FLOODED** refrigeration systems check to make sure the float valve is working properly and allows refrigerant into the drum to the appropriate level when the level is sufficiently low. If a hand expansion valve has been added, the valve should be set to allow liquid make up 70% of the time.

For **DIRECT EXPANSION** systems let the system balance out at the desired room temperature and check the operation of the expansion valve by properly measuring the superheat at the sensing bulb. As much as thirty minutes may be required for the new balance to take place after an adjustment is made.

For **BRINE** or **WATER COOLING** systems keep the closest vent to the coil open while the fluid fills the coil to allow trapped air to escape. Close the vent valve once fluid flows out of the valve and check for water hammer in the coil.

With **HOT GAS DEFROST** systems allow the coil to frost, then manually advance the defrost timer to initiate a defrost cycle. Observe the defrost cycle to see if all controls are functioning properly and that the coil is clear of all frost before the system returns to refrigeration. Adjust the time clock pins if necessary. Reset the defrost timer to the correct time of day. A defrost cycle is only needed when the frost build up is such that it impedes the airflow through the coil. The defrost requirements will vary on each installation and may change depending on the time of the year and other conditions.

With **ELECTRIC DEFROST** systems allow the coil to frost then manually advance the defrost timer to initiate a defrost cycle. Observe the defrost cycle to see if all controls are functioning properly and that the coil is clear of all frost before the system returns to refrigeration. Adjust the time clock pins if necessary. Reset the defrost timer to the correct time of day. A defrost cycle is only needed when the frost build up is such that it impedes the airflow through the coil. The defrost requirements will vary on each installation and may change depending on the time of the year and other conditions.

With **WATER DEFROST** systems allow the coil to frost then manually advance the defrost timer to initiate a defrost cycle. Observe the defrost cycle to see if all controls are functioning properly and that the coil is clear of all frost before the system returns to refrigeration. Adjust the time clock pins if necessary. Reset the defrost timer to the correct time of day. A defrost cycle is only needed when the frost build up is such that it impedes the airflow through the coil. The defrost requirements will vary on each installation and may change depending on the time of the year and other conditions.

maintenance

9 MAINTENANCE

A preventive maintenance schedule should be established as soon as the DT/DTX Series unit is installed. The unit should be inspected periodically for proper operation and build up of frost and debris.

WARNING: All power to the evaporator must be off before cleaning or performing maintenance.

9.1 DRAIN PAN

Inspect and clean the drain pan to insure free drainage of condensate. The drain pan should be cleaned regularly with warm water and soap.

If the drain pan needs to be removed, support the long dimension of the pan from underneath with a minimum of two 4x4s for one and two fan units, or two 6x6s for three and four fan units, so the outer sheet metal skin does not buckle and become damaged. Do not point load the center of the support beam. For longer pans more than one lifting device may be needed to keep the pan balanced when lifting. Remove unit end covers, if necessary. If the drain pan uses hot gas defrost make sure the coil is completely pumped out and isolated with hand valves to prevent refrigerant from escaping to the atmosphere. Remove the hot gas piping or electric wires if the unit has a Hot Gas or an electric defrost drain pan. Remove the drain line so that it is out of the way of the pan when it is being lowered. Remove the drain pan attachment bolts from the bottom of the evaporator unit and slowly lower the pan from the unit. Assemble pan in reverse order. Replace with new hot gas interlocking gaskets before tightening flange bolts.

9.2 COIL AND CABINET

Clean the coil, fan cabinet, fans, and fan guards with warm water and soap. A low pressure water hose is recommended to avoid water entering into electrical components and causing equipment failure.

The evaporator coil should be checked once a month for proper defrosting. Many variables affect coil frosting such as room temperature, type of product being stored or processed, how often new product is brought in, and the length of time the door to the room remains open. Summer conditions of high humidity can cause heavier frost loads and it may be necessary to change the number of defrost cycles seasonally.

9.3 FAN REPLACEMENT

To replace the fan the motor/fan guard assembly must be removed from the unit. Make sure the electrical power to the unit is off and locked out before performing any work on the unit. Do not use the electrical conduit to support the motor/fan assembly. Open the electrical cover on the back of the motor and remove the power supply wires, noting where they attach for reassembly. The motor/fan assembly will weigh approximately 45 lb. Remove the nuts

on the bottom two fan attachments then support the motor/fan assembly against the unit and remove the top two attachment nuts. Place the motor/fan assembly on a working surface. Make a mark on the motor shaft, on the motor side of the fan, locating the original fan. Remove the fan and deburr the motor shaft. Place the new fan on the shaft to the location mark and tighten fan hub set screw. Make sure the orientation matches the original fan. Reattach motor/fan assembly in reverse order as it was taken off. Test the fan rotation when putting the unit in normal operation.

9.4 MOTOR REPLACEMENT

Once the motor/fan assembly has been removed from the unit and the fan removed as described in section 9.3 also mark the existing motor where it is located in the belly band. Loosen the bolt that clamps the motor to the belly band and remove the motor from the fan guard assembly. Measure the fan location mark on the old motor and mark the new motor shaft in the same place, plus mark the new motor for the belly band location. Place the new motor in the belly band to the location mark and tighten belly band bolt. Assemble fan and attach to the unit as described in Section 9.3.

9.5 FAN GUARD AND BELLY BAND REPLACEMENT

Use the same procedure as in Sections 9.3 and 9.4. Note the old fan guard/belly band assembly and assemble the new parts together in the same way. Replace the motor and fan as described in Sections 9.3 and 9.4.

9.6 ELECTRIC DEFROST HEATER REPLACEMENT

Inspect the electric defrost heater ends to determine if they are operating. A heater will be operating properly when the heater is observed to be glowing during the defrost cycle. If a heater rod is cold during the defrost cycle it will need to be replaced.

Coil heaters require horizontal removal from one or both ends of the unit. On one through three fan units the heater rods are all on one end of the unit. Four through six fan units will have heaters on both ends of the unit. Turn off all electrical power on the unit. Remove power wires of the heater being replaced from the terminal block and note where original wires were located. Rotate the heater rod about 90° either way so that the heater and factory attached retainer clip can be pulled through the coil endplate slot. Remove clip from the old heater rod and install on the new heater rod in approximately the same location as the original heater. Install the new heater rod in the original coil slot, rotate the rod 90°, and replace the wires in the positions of the original wires in the terminal block.

Turn off all electrical power on the unit.



maintenance

Drain pan heaters require the drain pan to be removed. Support the long dimension of the pan from underneath with minimum units, so the outer sheet metal skin does not buckle and become damaged. For longer pans more than one lifting device may be needed to keep the pan balanced when lifting. Remove the heater wire from terminal blocks. Remove the drain line so that it is out of the way of the pan when it is being lowered. Remove the drain pan attachment bolts from the bottom of the evaporator unit and slowly lower the pan from the unit. Remove clips from the heater's hold down brackets and remove brackets. Replace the heater. Replace the hold down brackets and assemble the pan in reverse order. Rewire heaters in original terminal blocks.

9.7 WATER DEFROST DISTRIBUTION PAN REPLACEMENT

The Water Defrost distribution pan is removable from the rear of the unit for cleaning or replacement. Disconnect the water piping from the pan inlet connection. Remove the access plate from the front of the water pan section and slide out the water distribution pan. Reassemble in the reverse order.

10 REPLACEMENT PARTS LIST

Following are the major replacement parts of the standard DT Series units. The full Model Number, Serial Number, and voltage will be necessary to identify the correct replacement part.

Description	Voltage	Part Number
Motor 1140 RPM 1/4 hp	115/208-230/50-60/1	11079
Motor 1140 RPM 1/3 hp	115/208-230/50-60/1	11078
Motor 1140 RPM 1/2 hp	115/208-230/50-60/1	11080
Motor 2 Speed 1140/850 RPM 1/2 hp	208-230/50-60/3	E310112
Motor 1140 RPM 1/3 hp	208-230/380/460/50-60/3	11507
Motor 1140 RPM 1/2 hp	208-230/380/460/50-60/3	11096
Motor 2 Speed 1140/850 RPM 1/2 hp	460/50-60/3	11508
Motor 1140 RPM 1/2 hp	575/60/3	11506
Motor Inverter Duty 1/2 hp	230/460/3/60	11096I
Fan Guard		22845
Motor Mount 1PH 48 Frame		22849
Motor Mount 3PH 56 Frame		22850
22" Diameter Fan 21 Degrees CW 5/8 Bore		11251
22" Diameter Fan 27 Degrees CW 5/8 Bore		11252
22" Diameter Fan 21 Degrees CCW 5/8 Bore		11258
22" Diameter Fan 24 Degrees CCW 5/8 Bore		11259
22" Diameter Fan 17 Degrees CCW 5/8 Bore		11256
22" Diameter Fan 19 Degrees CCW 5/8 Bore		11257
22" Diameter Fan 24 Degrees CCW 5/8 Bore		11259
Long Throw Adapters		E700281

Description	Voltage	Part Number
HTR-COIL 1000W 230V	230/380	17784
HTR-COIL 1500W 230V	230/380	17785
HTR-COIL 500W 230V	230/380	17788
HTR-COIL 1000W 265V	460	17781
HTR-COIL 1500W 265V	460	17782
HTR-COIL 500W 265V	460	17787
HTR-COIL 1000W 332V	575	E315470
HTR-COIL 1500W 332V	575	E315471
HTR-COIL 500W 332V	575	E315472

maintenance

Description	Voltage	Part Number
HTR-PAN 301W 230V	230/380	21756
HTR-PAN 476W 230V	230/380	21757
HTR-PAN 648W 230V	230/380	21758
HTR-PAN 411W 230V	230/380	21759
HTR-PAN 498W 230V	230/380	21760
HTR-PAN 585W 230V	230/380	21761
HTR-PAN 301W 265V	460	21762
HTR-PAN 476W 265V	460	21763
HTR-PAN 648W 265V	460	21764
HTR-PAN 411W 265V	460	21765
HTR-PAN 498W 265V	460	21766
HTR-PAN 585W 265V	460	21767
HTR-PAN 301W 332V	575	E315473
HTR-PAN 476W 332V	575	E315474
HTR-PAN 648W 332V	575	E315475
HTR-PAN 411W 332V	575	E315476
HTR-PAN 498W 332V	575	E315477
HTR-PAN 585W 332V	575	E315478

Number of Fans	Drain Pan Part Number	Number of Drip Pans	Splash Guard Part Number
1	E318030	1	E318017
2	E318018	1	E318006
3	E318019	1	E318007
4	E318018	2	E318008
5	E318018	1	E318009
	E318019	1	
6	E318019	2	E318010

Description	Number of Fans					
	1	2	3	4	5	6
Aluminum (A, HGC, ED) Non-Insulated	21082D	21084D	21086D	21088D	21090D	21092D
Aluminum (A, HGC, ED) Insulated-Mill Galvanized Cover	21130D	21131D	21132D	21133D	21134D	21135D
Aluminum (A, HGC, ED) Insulated-Stainless Cover	21118D	21119D	21120D	21121D	21122D	21123D
Aluminum (230-EDL) Insulated-Mill Galv. Cover	21781D	21782D	21783D	21784D	21785D	21786D
Aluminum (230-EDL) Insulated-Stainless Cover	21787D	21788D	21789D	21790D	21791D	21792D
Aluminum (460-EDL) Insulated-Mill Galv. Cover	21793D	21794D	21795D	21796D	21797D	21798D
Aluminum (460-EDL) Insulated-Stainless Cover	21799D	21800D	21801D	21802D	21803D	21804D
Aluminum (WD) Non-Insulated	CE318069	CE318070	CE318071	CE318072	CE318073	CE318074

Orientation	Number of Fans											
	1		2		3		4		5		6	
	LH	RH	LH	RH	LH	RH	LH	RH	LH	RH	LH	RH
Stainless (HGS, HGP) Insulated Mill Galv. Cover	21021Y	21021Z	21022Y	21022Z	21023Y	21023Z	21024Y	21024Z	21025Y	21025Z	21026Y	21026Z
Stainless (HGS, HGP) Insulated Stainless Cover	21021O	21021N	21022O	21022N	21023O	21023N	21024O	21024N	21025O	21025N	21026O	21026N

Note: Replacement EDL drain pans include electric heater rods. Replacement HGS, HGP drain pans do not include companion flanges, new gaskets, bolts, or nuts for the hot gas interpipng connections.

