

# ABHi

BASIN HEATER CONTROLS

engineering data  
and specifications



MARLEY® 

**ABHi-ADVANCED BASIN HEATER CONTROLS**

The Marley ABHi integrated basin heater package controls the ON and OFF operation of the basin heater device providing freeze protection in the cold water collection basin of a cooling tower. This system is designed to be integrated into a Marley control panel along with other cooling tower controls e.g. fan motor VFD and basin heater controls. The integrated control package includes a main circuit breaker disconnect that feeds a contactor providing power for the heater element or steam solenoid valve.

The solid-state temperature controller is programmed to monitor water temperature in the cold-water basin and control the heater element or steam valve. The controller has a two-line display for PV (process variable) and SV (setpoint variable) values. The value shown on the PV line is water temperature in the basin being monitored by the temperature sensor and the value shown on the SV line is the set point.

A RTD (resistant temperature device) monitors water temperature in the basin for the temperature controller. The Marley RTD sensor includes a low water cutout circuit preventing the control from energizing if the sensor is not submerged in water. Standard sensor lead length is 30 feet (9 meters) while longer leads are available. The factory lead may be lengthened in the field or a sensor with extra-long lead may be ordered. Maximum distance is 200 feet (61 meters) as tested. An alarm contact will close when the temperature approaches a freezing condition for indication back to a BMS (building management system).

**SEQUENCE OF OPERATION**

Utility power applied to the main disconnect provides all required power to the internal and external circuits including the basin heater element. The main disconnect provides a means to isolate the incoming utility voltage.

The temperature controller monitors water temperature in the cold-water basin of the cooling tower via the RTD providing ON and OFF operation of the basin heater element. A set point temperature resides in the controller factory programmed at 42°F (5.5°C) with an operating band width of 5°F (2.8°C). When the temperature drops to 40°F (4.4°C) the controller energizes the power contactor to the ON position energizing the basin heater element. The controller de-energizes the power contactor OFF at 45°F (7.2°F). An alarm contact closes if temperature in the cold-water basin is 35°F (1.7°C) or less.

The Marley RTD provides dual functions, temperature and low water cutout safety circuit. The low water cutout circuit will not allow the heater to energize unless the sensor is submerged in water. The sensor is located about one inch higher than the heater element assuring the heater element is covered with water before energizing.

The basin heater element may be provided with a TCO (thermal cut out) safety device which acts as a one-time thermal fuse. If the heater element reaches an overheated condition the TCO opens the safety circuit of the ABH circuit de-energizing the power contactor. This is a one-time thermal fuse and is field replaceable.

**SYSTEM DIAGRAM**

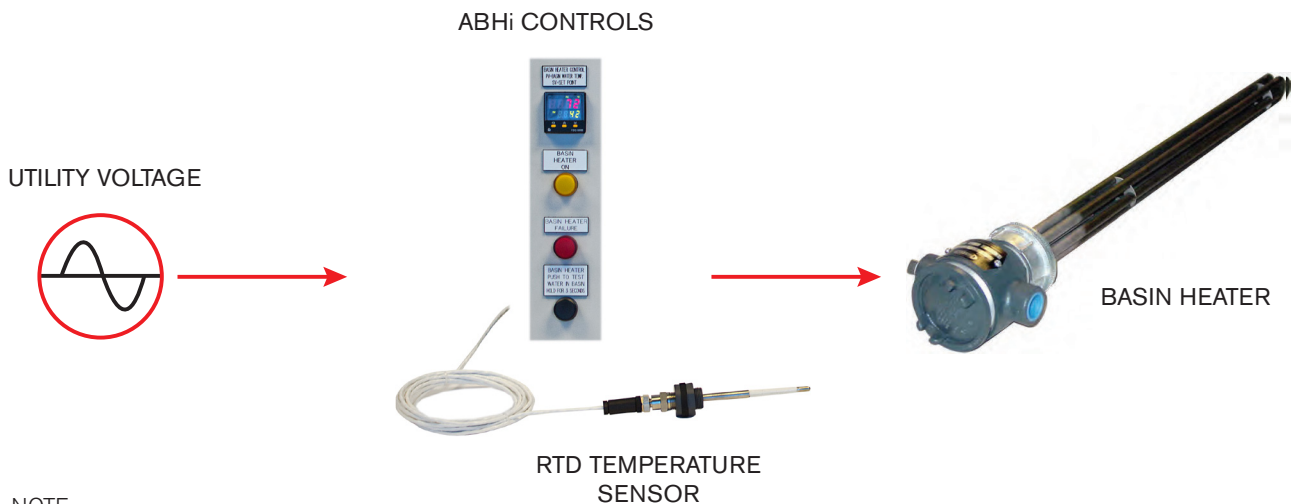

**NOTE**

- 1 When using multiple heater elements, wire the heaters in parallel and route three wires and ground to the ABH control panel.
- 2 Heater element may have a two-wire thermal cutout. These two wires may be run in same conduit as the power wiring. Follow local electrical codes.

## ABHi CONTROLLER DETAILS

Solid-state temperature controller with dual display and adjustable set points  
Low water conductivity cutout safety circuit  
Freezing water low temperature alarm contact  
Push-to-test button to check if basin heater element is functional  
Basin heater ON pilot light  
Basin heater FAILED pilot light with dry contact output status  
Low water cutout protection for the heater element  
User terminal strip for status and RTD terminations  
Low temperature alarm contact wired to used terminal strip  
RTD PT-100 temperature sensor with long lead voltage drop compensation  
30 foot plug on lead for temperature sensor is standard  
Remote heater testing ability via customer's dry contact closure

## COMMUNICATIONS

1 – N.O. dry alarm contact closes at 35° F  
1 – N.O. dry contact closes when the power contactor closes  
1 – N.O. dry contact closes for basin heater ON confirmation  
1 – N.O. dry contact closes for basin heater failure confirmation

## REMOTE PROVISIONS

Heater element operation may be remotely checked via dry contact closure  
Second set point may be selected via remote dry contact closure  
Run enable via remote dry contact closure

## SETTINGS

Adjustable 42°F (5.5°C) set point  
ON at 40° (4.5°C), OFF at 45° (7.2°C)  
Adjustable freezing alarm contact at 35°F (1.7°C)

## OPTIONS

4-20mA output representing basin water temperature (optional plug in module)  
Other specials are considered on a job by job basis

**Voltage Ratings**

- Q What are the available voltage ratings?
- A 575V, 480V, 240V, 208V, and 380V 50/60Hz. Contact SPX for other voltage options.

**Temperature Sensor**

- Q Is the temperature sensor furnished with wire?
- A Yes – 30 foot lead is standard.
- Q Can sensor leads be extended?
- A Yes – use #18 gauge 5 wire stranded copper conductor plus a shield.
- Q Are longer sensor leads available from the factory?
- A Yes – 30 foot leads are standard and leads are available in 100', 150' and 200' lengths.
- Q Can leads be cut to length?
- A Yes.
- Q Are sensor leads replaceable?
- A Yes – the lead attaches to the sensor with a plug and screw connector.
- Q Does the sensor require maintenance?
- A Yes – the sensor should be cleaned during normal maintenance inspections.
- Q Does the sensor lead need to be in conduit?
- A The wire is rated for outdoor use (check local codes).
- Q Is a low water cutout circuit required?
- A Yes – the temperature sensor is a combination probe with an integral low water cutout circuit already built into it therefore no additional wiring or components required.
- Q How is the sensor mounted?
- A Typical location is through the side wall of the cold water basin near the heater element and pump suction area. Bulkhead compression fittings are supplied with the sensor.

**Integration**

- Q Is the ABHi designed be integrated into other Marley control panels?
- A Yes – the system may be integrated into the Marley AIO or SPPC control panel.

**Temperature Controller**

- Q Is the controller solid state?
- A Yes.
- Q Is the controller factory programmed?
- A Yes - set point 42°F (5.5°C).
- Q Is the controller programmable in the field?
- A Yes.
- Q Can the set point temperature be locked out with a security code?
- A Yes.
- Q Does the display show water temperature?
- A Yes.
- Q Does the display show set point temperature?
- A Yes.
- Q Is a 4-20mA water temperature signal available?
- A Yes – as an option.

**Pilot Lights**

- Q Are pilot lights LED type?
- A Yes.

**Wiring**

- Q How are heater elements wired back to the control panel?
- A A cooling tower cell may be furnished with 1, 2, 3 or 4 heater elements depending on amount of heat needed. The heater elements should be wired in parallel and 3 wires plus ground brought back to the control panel.
- Q What is the purpose of the two white wires labeled C1 and C2 located in the conduit head of the heater element?
- A This is a secondary safety circuit in case the heater element overheats. These two wires should be wired back to terminal points C1 and C2 in the ABHi controls and may be run in the same conduit as the power feed. Use wire insulation rated for the feeder voltage. If C1 and C2 are not electrically connected the ABHi controls will not operate.

**Electrical Standards**

The assembly is built to the following industrial control panel standards:

UL 508A CUL 508A NFPA 70 (NEC)

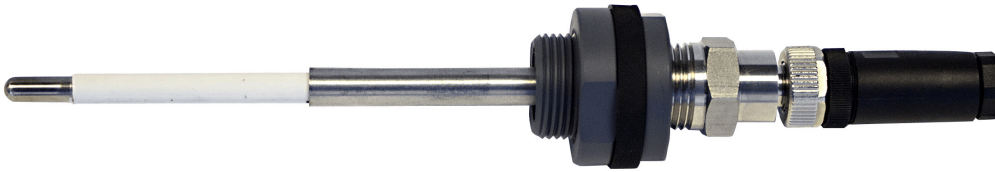

Marley RTD Sensor Type PT-100 with bulkhead fitting.

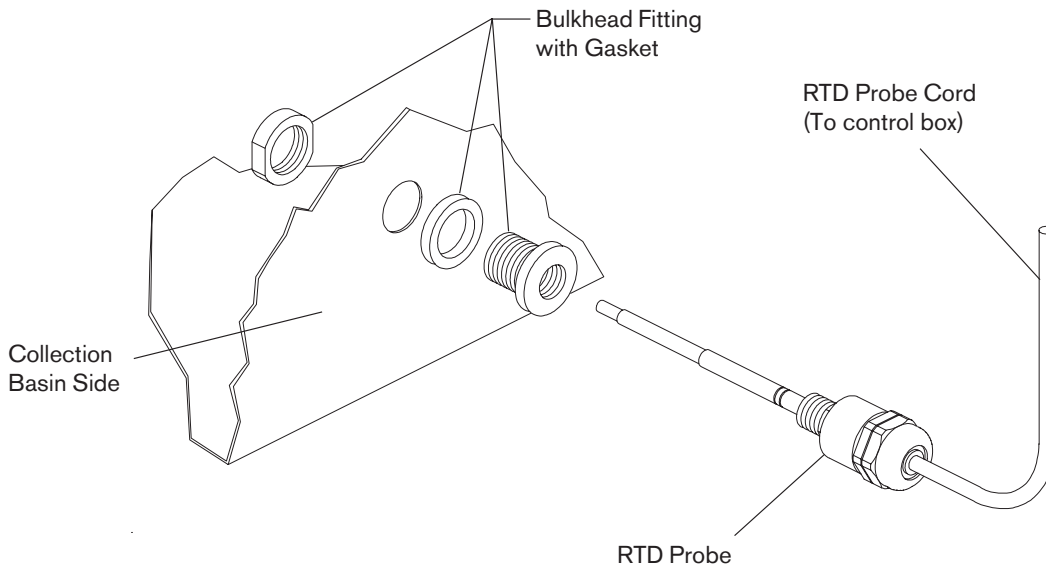
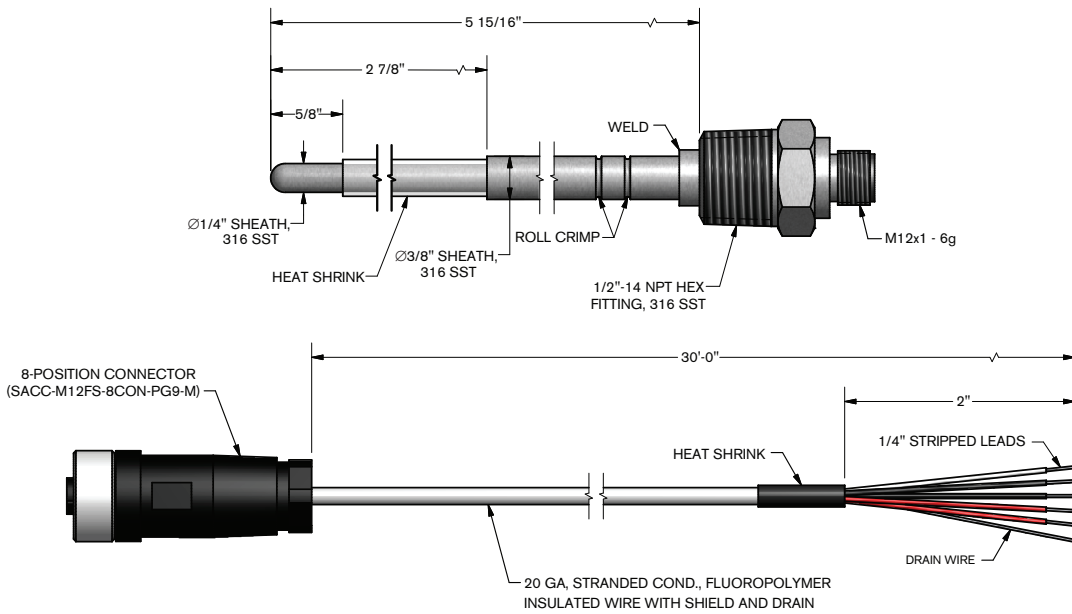

3 phase heater element system						
			Total number of heater elements per control panel			
			1	2	3	4
kW	Volts	Amp draw	Main circuit breaker size in amps			
3	208	8	15	20	30	50
4.5	208	13	20	30	50	60
6	208	17	25	40	60	80
7.5	208	21	25	50	70	100
9	208	25	30	60	80	125
12	208	33	40	80	125	150
15	208	42	50	90	150	175
18	208	50	60	125	175	225
3	240	7	15	20	30	40
4.5	240	11	15	30	40	50
6	240	14	20	40	50	70
7.5	240	18	25	40	60	80
9	240	22	30	50	80	100
12	240	29	40	70	100	125
15	240	36	50	80	125	175
18	240	43	50	100	150	200
3	380	5	15	15	20	30
4.5	380	7	15	20	30	40
6	380	10	15	25	40	50
7.5	380	12	15	30	50	60
9	380	14	20	40	50	70
12	380	19	25	50	70	90
15	380	23	30	60	80	100
18	380	28	40	70	100	125
3	480	4	15	15	20	20
4.5	480	5	15	15	20	30
6	480	7	15	20	30	40
7.5	480	9	15	30	40	50
9	480	11	15	30	40	50
12	480	14	20	40	50	70
15	480	18	25	50	60	80
18	480	22	30	50	80	100
3	575	4	15	15	20	20
4.5	575	5	15	15	20	30
6	575	7	15	20	30	40
7.5	575	8	15	20	30	40
9	575	10	15	30	40	50
12	575	13	20	40	50	60
18	575	18	25	50	70	80

3 phase heater element system		
kW	Volts	Amp draw
3	208	8
4.5	208	13
6	208	17
7.5	208	21
9	208	25
12	208	33
15	208	42
18	208	50
3	240	7
4.5	240	11
6	240	14
7.5	240	18
9	240	22
12	240	29
15	240	36
18	240	43
3	380	5
4.5	380	7
6	380	10
7.5	380	12
9	380	14
12	380	19
15	380	23
18	380	28
3	480	4
4.5	480	5
6	480	7
7.5	480	9
9	480	11
12	480	14
15	480	18
18	480	22
3	575	4
4.5	575	5
6	575	7
7.5	575	8
9	575	10
12	575	13
15	575	15
18	575	18

1 phase heater element system		
kW	Volts	Amp draw
3	120	25
4.5	120	38
3	208	14
4.5	208	22
6	208	29
7.5	208	36
3	220	14
4.5	220	21
6	220	28
7.5	220	34
9	220	41
3	240	13
4.5	240	19
6	240	25
7.5	240	31
9	240	38
4.5	480	9
6	480	13
7.5	480	16
9	480	19
12	480	25

# ABHi basin heater controls

ENGINEERING DATA

---

**SPX COOLING TECHNOLOGIES, INC.**

7401 WEST 129 STREET  
OVERLAND PARK, KS 66213 USA  
913 664 7400 | [spxcooling@spx.com](mailto:spxcooling@spx.com)  
[spxcooling.com](http://spxcooling.com)

TECH-ABHi-19 | ISSUED 6/2019

©2018-2019 SPX COOLING TECHNOLOGIES, INC. ALL RIGHTS RESERVED  
In the interest of technological progress, all products are subject to design and/or material change without notice.

