

Geareducer[®] model 32.2

INSTALLATION - OPERATION - MAINTENANCE

Z0238997_D ISSUED 11/2022

READ AND UNDERSTAND THIS MANUAL PRIOR TO OPERATING OR SERVICING THIS PRODUCT

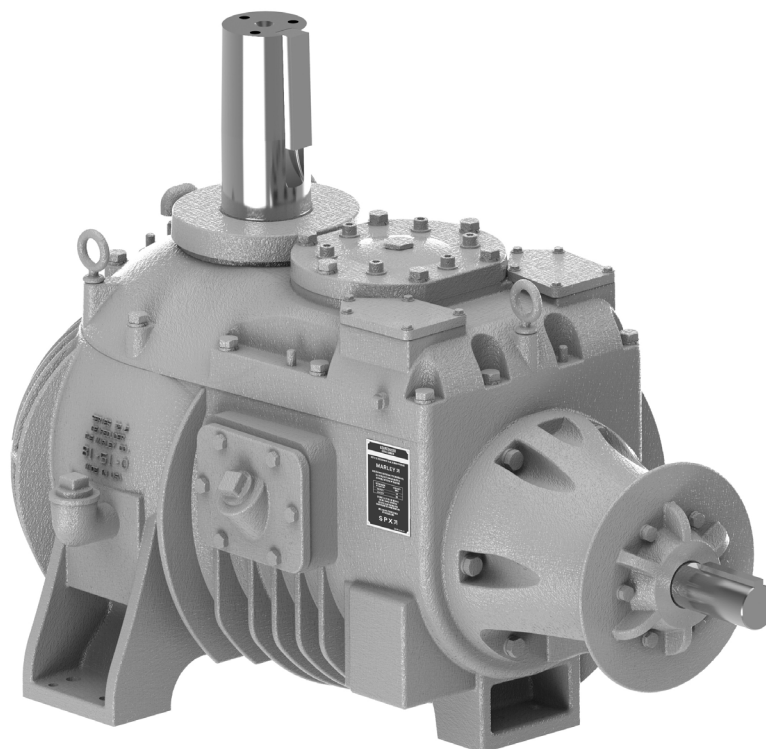

operation and service

Corrosion and Dry Start-Up Protection

Marley Geareducers utilize iron and steel materials, which if not maintained correctly, may degrade. While some external corrosion is acceptable, an internal lubrication film must be maintained at all times to protect the working components against corrosion and potential startup damage. The following information describes methods of operation and preventive measures to ensure suitability for long-term operation.

Status Definitions

Pre-Commission

Duration* = Up to 4 months after receipt.

*export shipment status duration is reduced by 1 month

This is the as-shipped condition, which contains a factory rust-proofing coating on the interior of the unit as well as a grease coating on the exposed shaft surfaces.

If the cooling tower is not ready for operation at the time of status expiration, steps must be taken to place the Geareducer into **Long-Term Storage or Downtime** status.

Operational

This stage is initiated upon the first motor driven sequence. The Geareducer is now considered as being placed into regular service and operation.

Idle

Duration = 2 to 4 weeks.

This stage is a suspension in operational status and lasts up to two 2 weeks. The duration may be doubled by completing a **Run Cycle**.

It is not recommended to extend the idle status more than once in any given sequence.

A common application is during a temporary outage

Seasonal Shutdown

Duration = Up to 4 months after operational is suspended.

This stage may be considered an extended idle condition.

Requires additional preventive maintenance.

Long-Term Storage or Downtime

Duration = Indefinite.

Requires long-term preventive measures.

Run Cycle

Defined as full speed operation for a minimum of 30 minutes. This recoats all internal components and surfaces with lubricant and also helps to expel some moisture that may have accumulated from daily ambient condition cycling.

As shipped, a Marley Geareducer is protected internally against corrosion with machine enamel on un-machined parts and with rust-proofing oil and grease on machined surfaces. These coatings normally protect the Geareducer against corrosion for the duration of the **Pre-Commission** phase. Adding normal lubricant to the unit will dissolve the rust-proofing oil in the Geareducer sump. Provided it is added via the filler-neck or pumped in through the drain connection, this lubricant will not reduce the overall level of protection however, if the unit is operated for any amount of time, the **Pre-Commission** period is depleted and the unit is now considered to be in **Operational** status.

Check the Geareducer exterior yearly. Touch up with paint as required. Exposed pipe threads are coated to prevent corrosion. Touch up coating as required.

Initial Operation

Priming

Due to lack of control over facility operational readiness, site ambient conditions or storage practices, etc., it is recommended to supplement lubricant prior to initial operation. The same fill lubricant should be poured or pumped into the port above the interstage shaft. Remove pipe plug in center of Interstage Bearing Cap to expose port. Refer to **Figure 1**. If additional oil is being used, an amount of 1 to 1 1/2 quarts should be used. If the lubricant is being pumped from the sump bulk volume, at least 1 quart **should** be transferred. In either case, this priming step should be performed within 5 days of initial operation. If a delay occurs and the 5 day duration is exceeded, repeat the process. In either case, this priming step should be performed **while rotating the gear train by hand** and within 5 days of initial operation.

Warning – Operating the Geareducer at an oil level other than between the Add and Full levels may damage the unit and possibly mating equipment. This could also escalate to a safety concern for nearby personnel.

The Geareducer must be filled with oil to the Full oil level mark on the Geareducer case before it is placed in operation. If the unit is being taken out of **Long-Term Storage or Downtime**, the oil should be drained down to the Full operating level. If drain-down occurs within 5 days of the initial startup, the above priming sequence may be skipped. See **Change Geareducer Oil** section for oil filling instructions.

Geareducers supplied with new cooling towers include oil for the initial filling and in some cases, will also ship with an additional amount required to place the unit into **Long-Term Storage or Downtime** status. Normally, oil is not furnished with Geareducers supplied as a spare or on replacement orders. Before operating the mechanical equipment, check to be sure the oil level is at the Full mark at the Geareducer and that the external gauge placard Full mark corresponds with the Full level in the Geareducer. Check oil lines to be sure there are no leaks.

operation and service

The Geareducer vent or vent line must be checked for blockage to prevent failure of pinion shaft oil seal—clean when necessary.

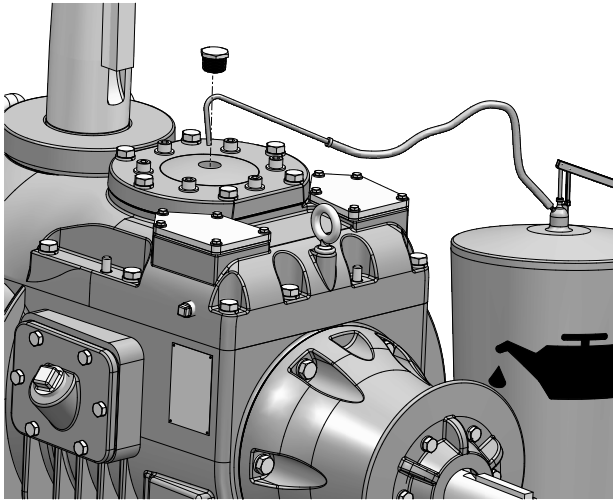

Figure 1 Priming Interstage Shaft

Check all gasketed joints for oil seepage. Tighten cap screws and flange bolting if necessary.

The Geareducer must be installed level and properly aligned with the driveshaft and motor shaft. Refer to the ***Driveshaft User Manual***.

It is recommended to operate the Geareducer for no less than 30 minutes in any given run sequence. It is acceptable to ignore this when “bumping” the motor for confirmation of the correct direction of rotation.

Seasonal Shutdown up to 4 months

At start of shutdown period, perform a ***Run Cycle*** and change the oil. See section on ***Changing Geareducer Oil***.

Every 2 weeks check the oil level and perform a ***Run Cycle***.

Once each month drain any water condensation from the lowest point of the Geareducer and its oil system. Check the oil level and add oil if necessary. Perform a ***Run Cycle***.

To put back into operation, drain water condensation from the lowest point of the Geareducer and its oil system and check oil level. Add oil if necessary.

Long-Term Storage or Downtime indefinite duration

If unit has been in an operational state, perform a ***Run Cycle*** and drain the oil including volume in the oil line, if equipped. If in storage, unit does not need to be operated.

Fabricate and install an overflow reservoir system and fill unit entirely full of oil.

Maintenance Cycle If unit is stored outdoors, drain condensate monthly and top off oil as necessary. If unit is stored indoors, but not climate controlled, maintenance cycle may be extended to 3 months. If stored in climate controlled space, cycle may be extended to once per year.

See *Marley User Manual Z0238848 “Cooling Tower Downtime Instructions”* and *Marley Drawing Z0544916 “Marley Geareducer Reservoir System”* for further information.

Inspection Of Internal Parts

Remove the inspection cover plate from the side of the Geareducer case at each oil change. Check inside of Geareducer for cleanliness of case and internal parts. If any sludge is present, flush inside of Geareducer and connecting oil line.

Also at this time, observe the contact pattern of the gear teeth to see if they appear as illustrated in **Detail A** and **B**. If incorrect gear tooth pattern should occur, refer to *Marley Field Repair Manual* for Series 32.2 Geareducer.

operation and service

CORRECT PINION AND RING GEAR TOOTH CONTACT PATTERNS

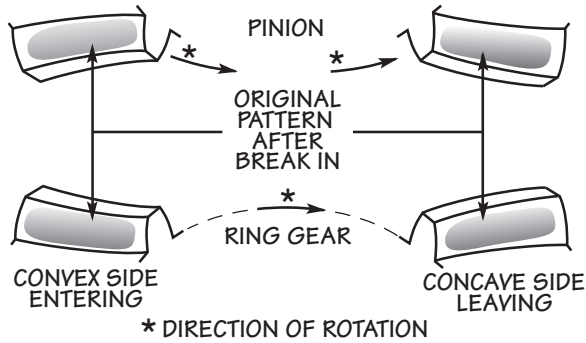

INCORRECT RING GEAR TOOTH CONTACT PATTERNS

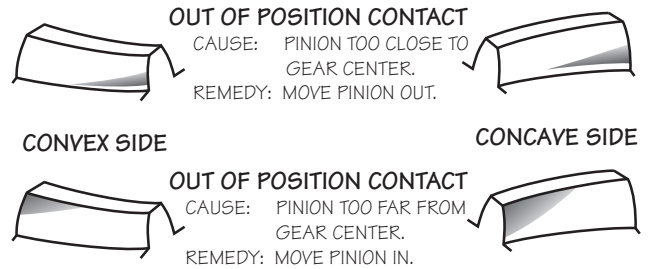

Detail A Spiral Bevel Gear Tooth Pattern

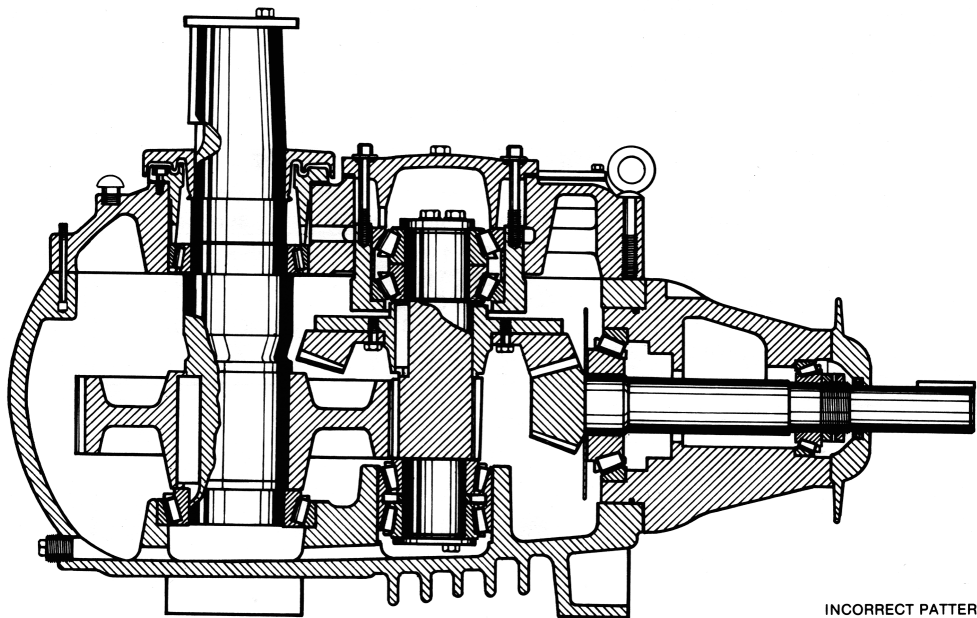

INCORRECT PATTERN

CHECK TOP INTERSTAGE BEARING AND BOTTOM FAN SHAFT BEARING. IF ONE OR BOTH ARE WORN, REPLACE.

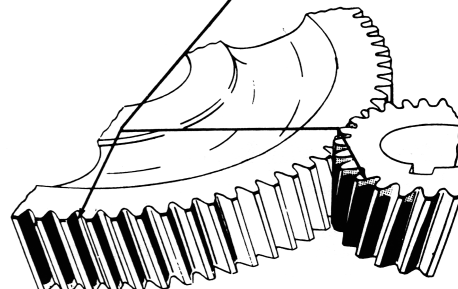
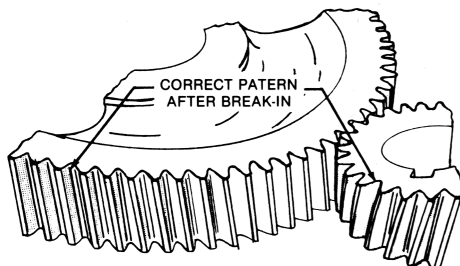

Detail B Helical Gear Tooth Pattern

operation and service

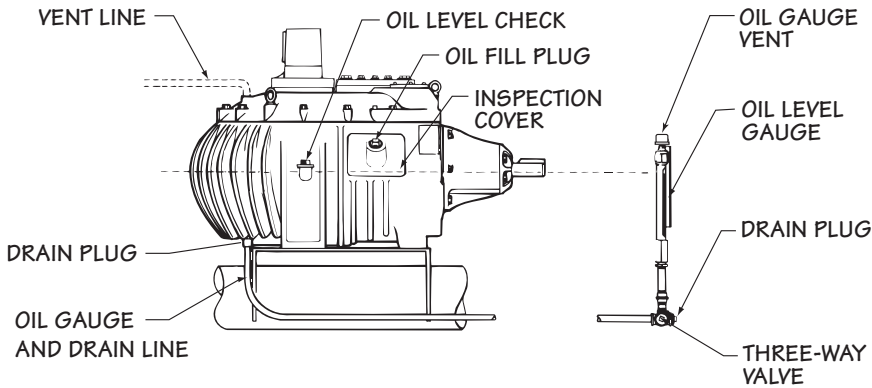

Figure 2 Oil Gauge and Drain Line (Series 36 Geareducer is illustrated)

Changing Geareducer Oil

Drain the Geareducer oil by removing the drain plug. See **Figure 2** for location. If equipped with an external dipstick/oil level gauge, remove the drain plug at that location, and drain the entire system.

When using synthetic oil with extended service intervals remove a sample for lab analysis and look for evidence of foreign material, such as water, metal shavings or sludge. If you find unacceptable condensation or sludge, flush the Geareducer with mineral oil before refilling.

The horizontal part of the oil line must be level or slightly lower at the oil level gauge than at the Geareducer. The oil capacity of the 32.2 Series Geareducer: 9 gallons (34 liters)

The oil level gauge line requires approximately one additional gallon of oil. Refer to back cover for suggested lubricants. If the Geareducer is equipped with an external dipstick/oil level gauge

an additional 3 to 4 quarts of oil will be required. Be certain that the vent on the Geareducer (and external dipstick/oil level gauge, if present) is not plugged. Verify that the gauge/drain line is full and that there aren't any leaks at the connections. Fill the Geareducer and oil line system with oil, using one of the following procedures:

Recommended procedure:

1. Install oil at the opening at the Geareducer inspection cover. Full is the center of the sight glass. If oil is **not** visible in the sight glass then oil needs to be added. See **Figures 2** and **3** Install plug.
2. Start the fan drive and run for one minute.
3. Stop the fan drive. Allow ten minutes for oil level to stabilize and recheck oil level at the Geareducer.
4. If necessary, repeat steps 2 and 3 until stabilized oil level is at the proper level.
5. Check gauge placard location. Full mark on the placard must be at the same elevation as the Full mark at the Geareducer.

Alternate procedure:

The cooling tower has an external oil gauge and drain line equipped with a three-way valve below the oil level gauge. See **Figure 3**.

1. Remove pipe plug. Turn valve control stem clockwise to open drain.
2. With Geareducer drained, the three-way valve turned clockwise, and the pipe plug removed, connect fill source (usually a hose to a pump, to the three-way valve).

Pump oil through the hose. Check oil level occasionally by turning the valve control stem counterclockwise and allowing the oil level in the sight glass to stabilize.

Continue filling until full level mark is reached.

3. With the oil level at the full mark turn the valve control stem counterclockwise to close the drain and open the valve to the sight glass. Remove the oil filling line and reinstall pipe plug in the three-way valve.

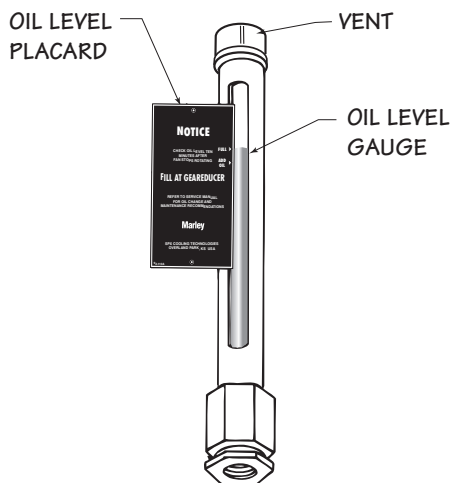

Figure 3 Sight glass gauge assembly

scheduled maintenance

Warning—Make certain that mechanical equipment is inoperable during periods of maintenance—or during any situation of possible endangerment to personnel. If your electrical system contains a disconnect switch, lock it out until the period of exposure to injury is over.

Monthly—Check Geareducer oil level. Shut down the unit and allow 5 minutes for the oil level to stabilize. Add oil if required, noting the addition in your maintenance log. If equipped with an external dipstick/oil level gauge, small quantities of oil can be added at that location.

Semi-annually—If using turbine-type mineral oil, change oil—see **Changing Geareducer Oil** for instructions. Check that all the assembly bolts and cap screws are tight, that oil plugs and pipe connections are in place and free from leaks, and that the vent on the Geareducer (and external dipstick/oil level gauge, if present) is clear—a clogged vent can lead to oil leaks. Intermittent operation and extended periods of downtime can cause condensation of water in the oil. If using synthetic Marley Gearlube, the oil condition must be inspected every six months—see **Changing Geareducer Oil** for maximizing service life.

Annually—Check mechanical equipment anchor bolts, drive shaft coupling bolts, and coupling set screws. Tighten as required. Check Geareducer exterior yearly and touch up with epoxy paint if required. Coat all exposed threads at pipe joints to prevent corrosion.

Every 5 Years—If using synthetic Marley Gearlube, change oil. To maintain five-year change intervals, use only synthetic Marley Gearlube. It is recommended to monitor the oil condition every six months throughout the five-year period per the instructions in **Changing Geareducer Oil**.

Maintenance Service	Monthly	Semi-annually	Seasonal Startup or Annually
Geareducer Drive:			
Inspect and tighten all fasteners including oil plug		x	x
Check for and repair oil leaks	x	x	x
Check oil level	x	R	x
Change oil		R	R
Make sure vent is open		x	x
Check driveshaft alignment			x
Inspect and tighten driveshaft fasteners			x
Check driveshaft bushing / flex elements for unusual wear			x
Lube Lines (if equipped)			
Check for oil leaks in hoses and fittings	x	R	x

R – Refer to instructions within this manual

Note: It is recommended at least weekly, that the general operation and condition be observed. Pay particular attention to any changes in sound or vibration that may signify a need for closer inspection.

repair and lubricants

Repair and Overhaul

If your Geareducer ever needs replacement or repair, SPX Cooling Technologies recommends returning the unit to a Marley factory service center. Contact your Marley sales representative to discuss a course of action. The Marley Order Number on your cooling tower will be required if the Geareducer is shipped back to the factory for repair. Obtain a **“Customer Return Material”** tag from the Marley sales representative in your area. To find your Marley sales representative call **913 664 7400** or check the internet at **spxcooling.com**.

Major repairs require the use of a fully equipped machine shop. If you decide to repair or overhaul your Geareducer, refer to the **Field Repair** Section and Geareducer **Parts List**.

Suggested Lubricants

Table 1 provides viscosity for seasonal and severity of duty applications. Refer to Marley **SB-20** for a list of lubricants for consideration. Those products have been recommended by their respective manufacturers as acceptable for use in a Marley spiral bevel and/or helical Geareducer for cooling tower applications. This list is not an attempt to include all the lubricants that may be satisfactory. If lubricants other than those listed are used they must not contain any additives—such as detergents or EP additives—which are adversely affected by moisture and could reduce the service life of the Geareducer. Suitability of lubricants used other than those listed rests with the customer/owner and lubricant supplier. Geareducer Lubricants **SB-20** is available for download at **spxcooling.com**.

Winter or Summer	Severe Duty/High Temperature
Air Temperature at Geareducer	
Below 110°F (43°C)	Above 110°F (43°C)
ISO 150	ISO 220

Table 1 Oil viscosity

Geareducer 32.2

USER MANUAL

SPX COOLING TECH, LLC
7401 WEST 129 STREET
OVERLAND PARK, KS 66213 USA
913 664 7400 | spxcooling@spx.com
spxcooling.com

Z0238997_D | ISSUED 11/2022
© 2016-2022 SPX TECH, LLC | ALL RIGHTS RESERVED
In the interest of technological progress, all products are subject to design
and/or material change without notice.

