

6Q - 175 - 250 Series driveshaft

INSTALLATION - OPERATION - MAINTENANCE

Z0239004 B ISSUED 05/2026

READ AND UNDERSTAND THIS MANUAL PRIOR TO OPERATING OR SERVICING THIS PRODUCT



parts list

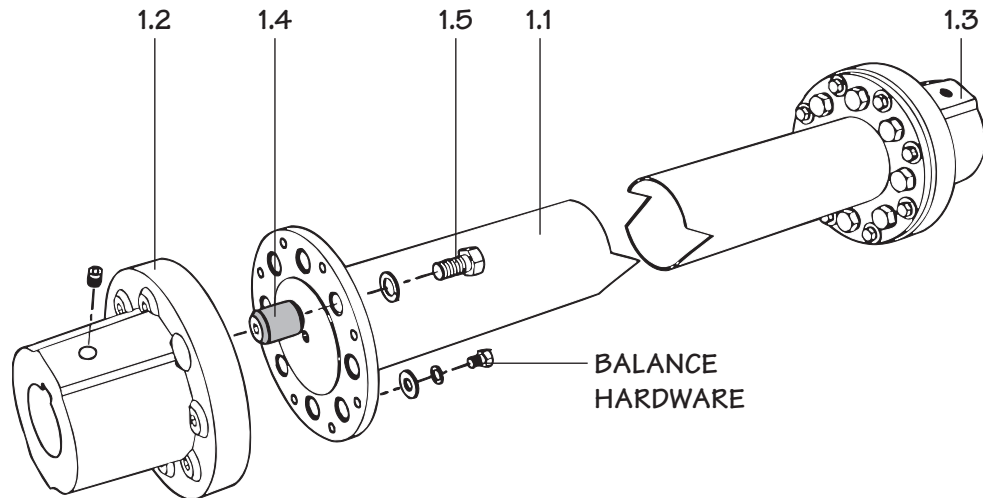

Figure 1 250 series shown

- 1.0** Complete driveshaft assembly
- 1.1** Tube and flange assembly
- 1.2** Geareduceryoke assembly with set screw
- 1.3** Motor yoke assembly with set screw
- 1.4** Bonded rubber bushing. 8 required for 6Q and 175 series driveshaft and 16 required for 250 driveshaft.
- 1.5** Machine bolt or cap screw with lock washer. 8 required for 6Q and 175 series driveshaft and 16 required for 250 driveshaft. The 175 driveshaft also requires 8 nuts.

Note

Complete driveshaft assemblies are dynamically balanced at the factory. When replacement parts are installed, driveshaft may need to be rebalanced.

When ordering parts, always provide cooling tower serial number. Contact the Marley sales office or representative in your area for assistance.

installation

General

Marley driveshafts consist of a motor and Geareducer yoke with rubber bushings and a tube and flange assembly. Driveshafts are balanced dynamically and tube and yoke flanges are match-marked. See Figure 3. Do not change position or relation of match-marked components during installation.

Driveshafts must be rebalanced whenever yokes or tube and flange assemblies are replaced. The driveshaft may be rebalanced on the tower. See instructions on page 6.

Installation

Before installing the driveshaft, be sure the motor and Geareducer are on level bases and that their shafts are in reasonable alignment.

Note match numbers on the driveshaft flanges and remove the yokes. Coat the motor shaft and Geareducer shaft with "Thred-Gard" (Crane Packing Co.) or similar lubricant. Place the key halfway in motor and Geareducer shafts, then install yokes as shown in Figure 4. Use a rubber mallet or wood block when tapping yokes to prevent damage. Tighten each yoke set screw against key to 20 ft·lbf (27 N·m) torque.

Align match numbers on tube and yoke flanges and bolt the tube and flange assembly to the Geareducer yoke while supporting the motor end of the tube and flange assembly. Progressively tighten bolts to 60 ft·lbf (82 N·m) torque. Slide the motor so that motor yoke can be bolted to the tube and flange assembly without pushing or pulling on the bushings. Align match numbers and bolt the motor yoke to the tube and flange assembly. Progressively tighten bolts to 60 ft·lbf (82 N·m) torque. The distance between tube and yoke flanges should be as shown in Figure 4.

Alignment

Check the alignment of motor shaft, driveshaft and Geareducer shaft by measuring between the tube and yoke flanges. Alignment requires the distance between adjacent points on the two flanges not vary more than .005" as the points make one complete revolution. A preliminary check of alignment can be



installation

made by measuring between the flanges at four points: top, bottom and two sides. Alignment requires measurement with a dial indicator as described in the following section. A Marley **Dial Indicator Alignment Kit** is available from SPX Cooling Technologies.

Checking Alignment with Marley Dial Indicator Kit

1. Screw adapter bushing into one of the balancing holes on the tube flange. If necessary, remove any balance hardware. Reinstall balance hardware in original location before running the drive shaft.
2. Insert the dial indicator into the adapter until indicator point contacts the face of the yoke.

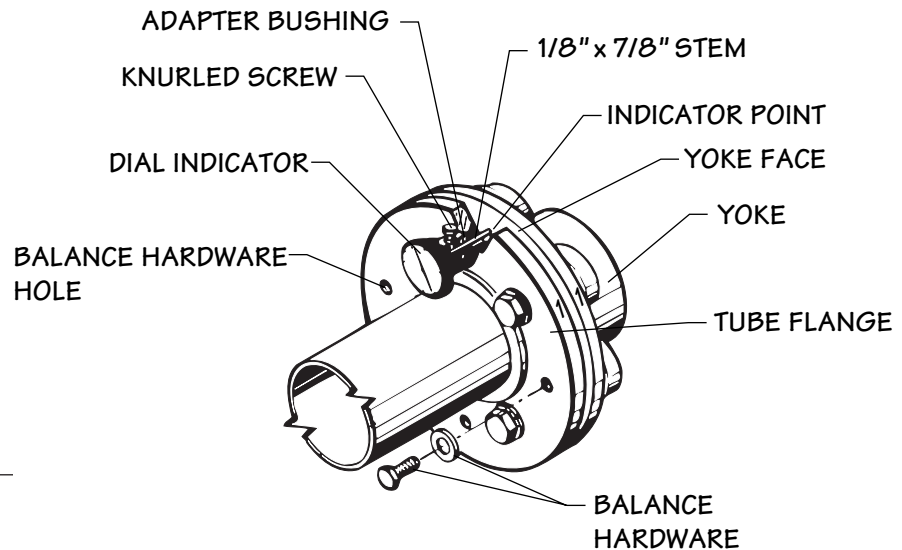

Figure 2 6Q series shown

3. The indicator point must remain in contact with the yoke face during one complete revolution, it must not at any time be pushed in so far that it bottoms out reaching the limit of the stem movement. The total travel of the indicator point is 0.100".
4. When the dial indicator has been positioned, tighten the knurled screw in the adapter enough to hold the indicator stem in contact with yoke face.
5. Check alignment at each end of the driveshaft by rotating the shaft 360° noting the total change in the reading on the dial indicator. Total indicator reading must not exceed .005". Move the motor and/or Geareducer verti-

installation

cally by shimming, or horizontally by shifting on support. Align driveshaft until the total indicator reading at each end is within .005". Tighten all mounting bolts on the motor and Geareducer, and recheck alignment. Maintain gap between face of flange and face of yoke as shown in Figure 4.

Vibration

Forced vibration is a condition where a mechanical system is caused to vibrate at other than a natural frequency. A forced vibration can result from driveshaft imbalance. Vibration at the driveshaft or motor shaft, rotating frequency as measured on the motor suggests driveshaft or motor rotor imbalance. The severity of imbalance is measured in terms of mils, or thousandths of an inch, displacement is usually read in peak-to-peak or double amplitude. For example, a vibration at .002" peak-to-peak at 29.3 CPS (1760 RPM/60 seconds = 29.3 cycles per second) could indicate a motor rotor or driveshaft imbalance.

Note

Drive shaft vibration resulting from imbalance can generally be reduced to .002" peak-to-peak, but in no case should it exceed .005".

If vibration is considered excessive and driveshaft imbalance is suspected on a fan-cell of a multicell tower, measure and record vibration amplitude and frequency in horizontal and vertical planes at the motor and at the Geareducer with all fans, except the one being tested, in operation. These readings will show the vibration introduced from outside sources. Do not attempt to compensate for this vibration within the fan-cell under test.

Start the motor on the test cell. Measure and record vibration amplitude and frequency at the same points and attitudes as above. Three sets of readings should be obtained and the average compared with vibration measured as described in the previous paragraph with the test cell not in operation. The differences in amplitude are the vibration characteristics of the test cell.

If operating conditions permit, stop all motors on the tower except in the test cell and measure vibration as before. This will verify test cell vibration characteristics as calculated above.

installation

Balancing

Note

When balancing a driveshaft on the cooling tower, do not exceed 30 seconds/hour total motor starting time. The motor may become overheated.

Add or remove washer weight or weights on one of the $\frac{3}{8}$ " balancing bolts in the driveshaft tube flange at the motor end. Figures 1 and 2. If improvement is made, continue to add or remove more washer weights at the same point.

Note

Adding weights at one point has the same effect as removing similar weights directly opposite (180°) . This can be used to keep the total weights to a minimum.

If vibration increases, restore original condition and repeat the same operation on a bolt 90° from starting point.

After the motor end is adjusted, repeat the same operation on the Geareducer end. Recheck the motor end to determine if the Geareducer end balance operation has increased motor end vibration reading. If so, repeat balancing of each end until no change in the opposite end is affected.

If a satisfactory balance cannot be obtained, turn the drive shaft tube and flange assembly end for end and repeat the balancing operation. Vibration readings can be taken on the motor with the motor yoke installed and the driveshaft disconnected to determine motor and yoke roughness. If vibration readings still indicate roughness, remove the yoke from the motor shaft and repeat the test to determine motor roughness.

Note

Marley driveshafts do not require lubrication.

Inspection of the complete driveshaft should be made at least every six (6) months. Look for corrosion, checking or cracking of rubber bushings, looseness of hardware, and alignment of the driveshaft. Accurate drive shaft alignment is required to insure maximum service life. Check alignment as outlined in the preceding section on page 4. Repair or replace drive shaft parts as necessary.

maintenance

Replacing Bonded Rubber Bushings

1. Remove the tube and flange assembly by removing the $\frac{5}{8}$ " machine bolts or cap screws at each end of the driveshaft. It may be necessary to loosen the motor mounting bolts and slide the motor back slightly to provide clearance for the tube and flange assembly to be removed.
2. Remove bushings by driving or pulling out of yoke sockets in the direction of the yoke face.
3. Clean yoke sockets but do not polish.
4. Lubricate bushing with rubber lubricant before inserting into the socket from the yoke face.
5. Using a C-clamp, press the bushing into the socket letting the sleeve end extend $\frac{1}{4}'' \pm \frac{1}{32}''$ beyond the 6Q and 175 series yoke face and $\frac{3}{16}'' \pm \frac{1}{32}''$ beyond the 250 series yoke face. Bushing bore must be perpendicular to the yoke face.
6. Care must be exercised to insure equal projection of all the bushings. Should it be necessary to straighten the bushing in the socket, insert a $\frac{5}{8}$ " bolt into the bushing and drive the bushing lightly from the side to attain perpendicularity between the bore of the bushing and the yoke face.
7. Replace the driveshaft tube and flange assembly. Be sure to match the numbers on the tube flanges with their respective numbers on the motor and Geareducer yokes. Install $\frac{5}{8}$ " machine bolts or cap screws in each end of driveshaft. Tighten to 60 ft-lbf (82 N·m) torque. See Figures 3 and 4.

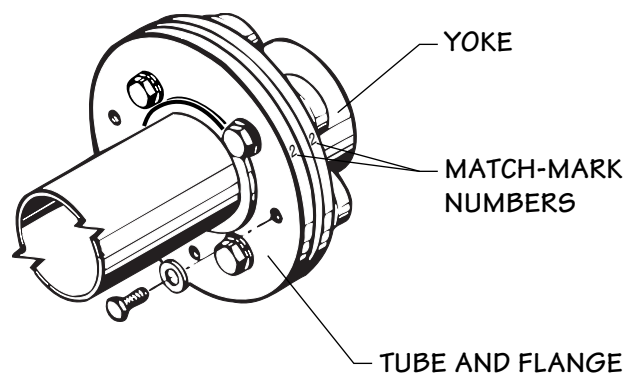

Figure 3 6Q series shown

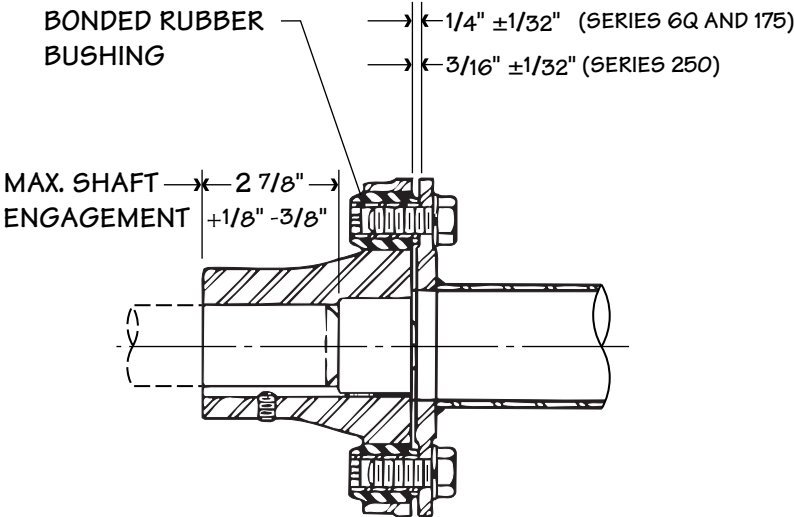

Figure 4 250 series shown

- 8. If the motor has been moved back to permit removal of the tube and flange assembly, reposition the motor, being sure that flange spacing is maintained. See Figure 4. Tighten the $5/8"$ machine bolts or cap screws to 60 ft·lbf (82 N·m) torque. For the 6Q and 175 series driveshaft, use an Allen wrench to prevent bushing from rotating in its socket. Recheck driveshaft alignment and tighten motor mounting bolts.
- 9. Rebalance driveshaft if necessary.