

301 - 400 Series driveshaft

INSTALLATION - OPERATION - MAINTENANCE

Z0440323 B ISSUED 5/2026

READ AND UNDERSTAND THIS MANUAL PRIOR TO OPERATING OR SERVICING THIS PRODUCT.

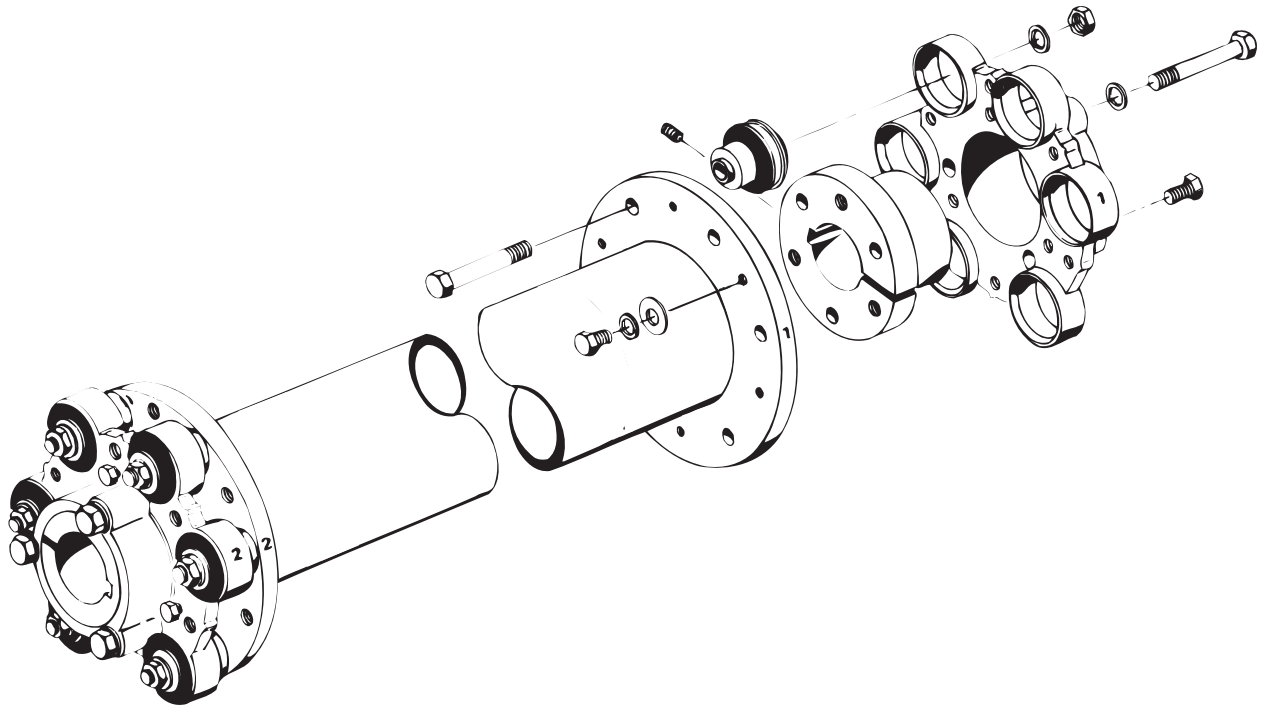

parts list

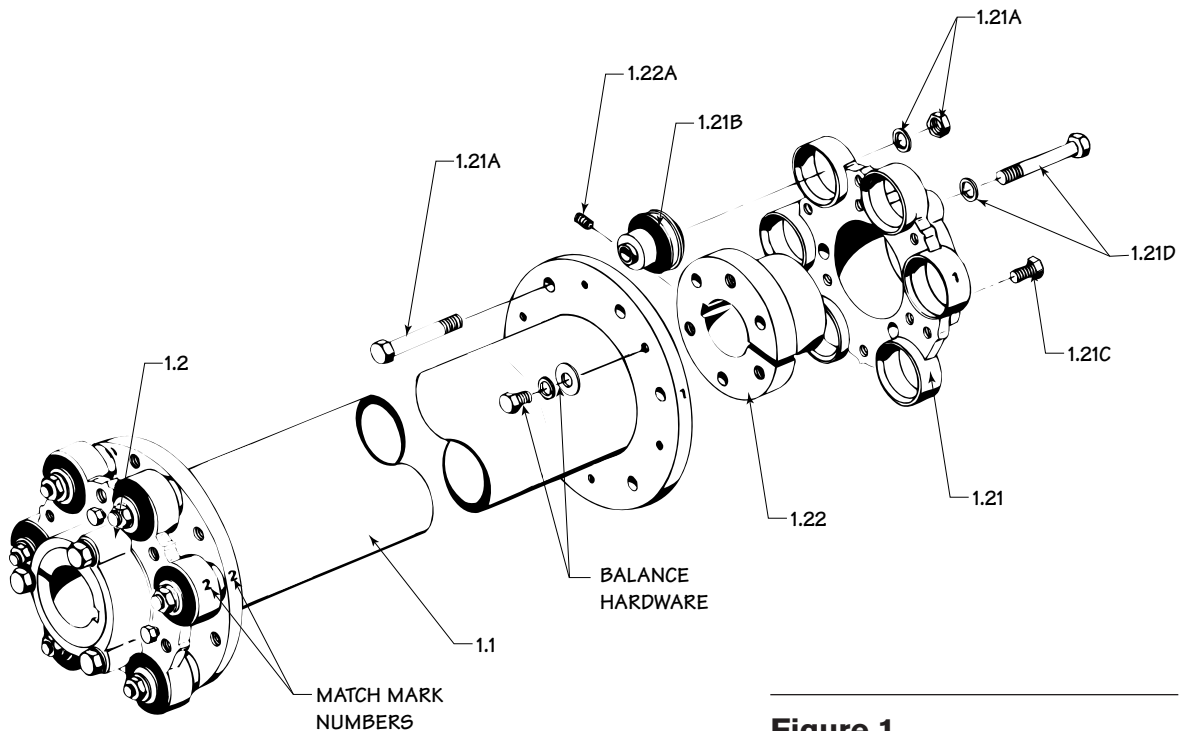

Figure 1

- 1.0 Complete Driveshaft
- 1.1 Tube Assembly
 - 301 series—stainless tube and flanges
 - 400 series—composite tube—stainless flanges
- 1.2 Coupling (2 required per driveshaft) complete with yoke, QDF bushing, flex bushings, cap screws, set screws, machine bolts, lock washers and nuts
- 1.21 Yoke
 - A Machine bolts with lock washers and nuts (6 required per yoke)
 - B Flex Bushing (6 required per yoke)
 - C Jacking screw (3 required per yoke)
 - D Cap screw with lock washer (3 required per yoke)
- 1.22 QDF Bushing
 - A Set screw (1 required per bushing)

Note

301 and 400 driveshafts also use a fixed bore yoke coupling instead of a cast yoke and QDF bushing. See page 5 for fixed bore yoke coupling parts list.

When ordering parts always provide the cooling tower serial number. Contact the Marley sales representative in your area for assistance.

installation

General

Marley 301 and 400 series driveshafts consist of a tube assembly with motor and Geareducer® couplings. Driveshafts are dynamically balanced. Tube and yoke flanges are match-marked as balanced. See Figure 1. Do not change position or relation of match-marked components during installation. When couplings, yokes, or tube assemblies are replaced, the driveshaft may need to be rebalanced. See page 8.

Note

400 series driveshaft tube assembly can be replaced or retrofitted to a 301 series driveshaft without rebalancing.

Some 301 and 400 driveshafts use a fixed bore yoke coupling instead of a cast yoke and QDF bushing. See page 5 for fixed bore yoke installation instructions.

Installation

Before installing the driveshaft, be sure the motor and Geareducer are on level bases and their shafts are in reasonable alignment.

- Note match-mark numbers on the driveshaft flanges then remove the yoke assembly from each end.
- Remove each QDF bushing from its yoke by removing the three cap screws attaching the yoke and bushing. If necessary, drive the bushing out of the yoke by progressively tightening the three jacking screws. Back the jacking screws out after removing the bushings.
- Remove any burrs or scratches from the motor and Geareducer shafts and coat the shafts with an anti-seize compound. Apply a thin layer of machine oil to the tapered surfaces of each QDF bushing.
- Start installation at the Geareducer end by slipping the yoke all the way onto the input shaft. Insert the key halfway into the keyway and slide the QDF bushing onto the shaft to obtain 3 5/8" engagement, see Figure 2. Tighten the set screw on the key to 20 ft·lbf (27 N·m) torque.
- Check to be sure the jacking screws are backed out then slide the yoke onto the QDF bushing and install the three cap screws through the yoke into the QDF bushing. Progressively tighten to 50 ft·lbf (68 N·m) torque. Do not lubricate these cap screws.
- Slip the motor yoke all the way onto the motor shaft and insert the motor key halfway into the keyway. Slide the QDF bushing onto the shaft so the QDF bushing and key are flush with the end of the shaft, but do not tighten the set screw.
- Lift the driveshaft tube assembly into place and support approximately level. Align the match marks at the Geareducer end.
- Install the six machine bolts through the flange of the tube assembly into the Geareducer yoke as shown in Figure 1. Make sure flex bushings are properly seated in the tube assembly flange. Progressively tighten all six bolts to 50 ft·lbf (68 N·m) torque.



installation

- Check to be sure the jacking screws are backed out then slide the motor yoke onto the QDF bushing and install the three cap screws into the bushing finger-tight.
- Align the match marks on the motor yoke and the tube assembly then install the six machine bolts through the flange engaging the nuts one or two turns only.
- Slide the coupling along the motor shaft so the flex bushings are started into the tube assembly flange, leaving a gap of about $\frac{1}{16}$ " (1.6mm) between the flange and the shoulders of the flex bushings.
- Install the three cap screws through the yoke into the bushing and tighten progressively to 50 ft·lbf (68 N·m) torque.
- Check engagement of the motor bushing on the motor shaft. If the QDF bushing extends beyond the end of the shaft, loosen the motor bushing cap screws and slide the motor in until the QDF bushing flange is within tolerance or adjust the position of the entire driveshaft assembly to get the same engagement at both ends. See Figure 2.
- When the engagement at both ends is within tolerance, tighten the set screw against the key on both Geareducer and motor shafts to 20 ft·lbf (27 N·m) torque. Tighten flange and bushing bolts progressively to 50 ft·lbf (68 N·m) torque. Tighten the jacking screws against the QDF bushing. Tighten all motor and Geareducer hold-down hardware.
- Check the torque on all driveshaft hardware.

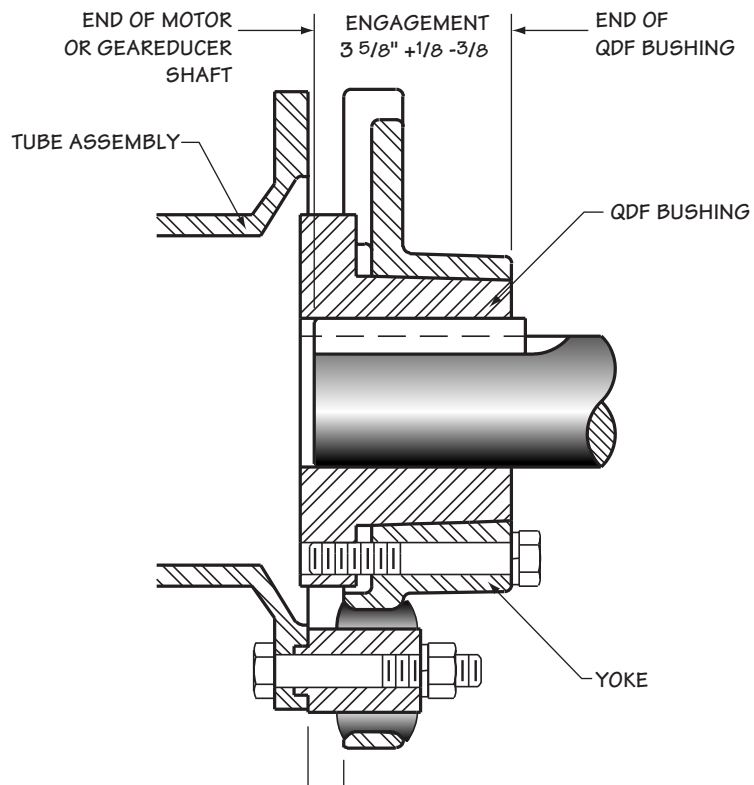

Figure 2

installation

Fixed Bore Yoke Installation

Fixed bore couplings are match-marked with the tube assembly when a complete driveshaft is purchased. Do not change the position or relationship of match-marked components during installation. Engage the fixed bore coupling on the shaft as described:

- The engagement for fixed bore couplings varies.
If your equipment uses a Marley Anti-Reversing Device (ARD), use the driveshaft engagement provided with the ARD installation instructions.
If your fixed bore yoke coupling has a bore 4" (100mm) or greater and you are not using a Marley ARD, the engagement is 4 $\frac{7}{8}$ " (124mm).
If your fixed bore coupling has a bore less than 4" (100mm) and you are not using a Marley ARD, the engagement is 3 $\frac{5}{8}$ " (92mm).
- Tighten the fixed bore coupling set screw(s) to 20 ft·lbf (27 N·m) torque.
- Refer to the preceding Installation instructions starting on page 3 to complete installation.

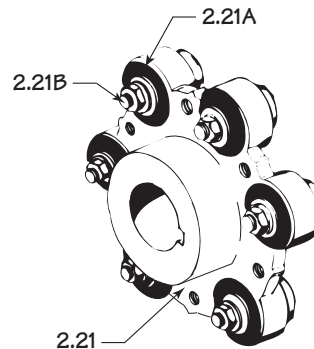

Figure 3

2.2 Coupling complete with yoke, flex bushings, cap screws, lock washers, nuts and set screw

2.21 Yoke with set screw(s)

A Flex Bushing

B Cap screw, lock washer, and nut

installation

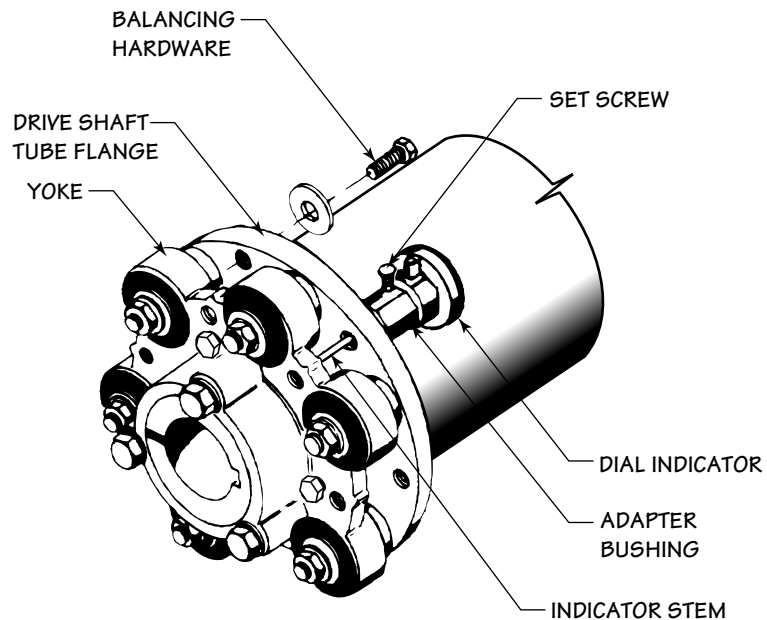

Figure 4

Alignment

Eliminate any large-scale misalignment before proceeding. A preliminary alignment check can be made by measuring between the driveshaft and yoke flanges. The distance should be approximately $1\frac{1}{16}$ " (17.5mm) measured at four points, see Figure 2. The final adjustment must yield a distance between adjacent points on the tube assembly flanges and coupling on each end that does not vary more than .005" (.13mm) through one complete revolution. A Marley **Driveshaft Alignment Indicator Kit** is available and can be purchased.

The following is a suggested procedure for using the Marley Dial Indicator Kit to check driveshaft alignment.

- Screw adapter bushing into one of the unused balancing holes on the tube assembly flange.
- Insert dial indicator into adapter until indicator point contacts the face of the yoke flange.
- The indicator point must remain in contact with the yoke during one complete revolution, but it must not at any time be pushed in so far that it bottoms out.
- When the dial indicator has been positioned, tighten the set screw in the adapter enough to hold the indicator.
- Check alignment at each end of driveshaft by rotating the shaft through 360° noting the total change in reading on the dial indicator. Total indicator reading must not exceed .005" (.13mm). Move motor and/or Geareducer vertically by shimming, or horizontally by shifting on support, to align driveshaft until the total indicator reading at each end is within .005" (.13mm).

installation

Note

Do not move the Geareducer or motor axially (closer together or farther apart) after driveshaft hardware is tight. The loads imposed on the driveshaft by these movements may reduce service life.

- Tighten all mounting bolts on motor and Geareducer, and recheck. Maintain gap between face of flange and face of yoke as shown in Figure 2. Remove dial indicator.
- Lock all jacking bolts at Geareducer support to assure permanent alignment. If jacking bolts are not provided, drill through the Geareducer feet and base plate and install dowel pins.

Maintenance

Note

Marley driveshafts do not require lubrication.

Inspection of the complete driveshaft should be made every six (6) months. Look for corrosion, checking or cracking of flex bushings, loose cap screws and set screws, or misalignment of the driveshaft. Accurate driveshaft alignment is required to insure maximum service life. Check alignment as outlined above. Repair or replace driveshaft parts as necessary.

These driveshafts must be rebalanced whenever couplings, yokes, or tube assemblies are replaced. The driveshaft may be rebalanced on the tower. See instructions on page 8.

Note

400 series driveshaft tube assembly can be replaced or retrofitted to a 301 series driveshaft without rebalancing.

Replacing Flex Bushings

- Locate match marks on yokes and tube flanges. If not identifiable, put new match marks on the edge of the flanges. Remove the tube assembly by removing the six machine bolts through the flex bushings at each end of the driveshaft. You may have to loosen one of the yokes and slide it back on its shaft before you can lift the tube out of the way.
- Remove QDF bushings and yokes from the motor and Geareducer shafts. Use the jacking screws in the yoke casting to push the yoke away from the bushing. Loosen the set screw over the key and slide the bushing and yoke off the shaft.
- Remove flex bushings by pressing or pulling out of yoke sockets. A C-clamp with a short piece of 3" diameter pipe works well to press the bushings out.
- Clean sockets but do not polish. Remove any burrs.
- Lubricate flex bushings with silicone lubricant before installation.



- Press the bushing, pilot end first, into the socket from the outside face of the yoke until the neoprene section of the bushing projects an equal amount from each side of the yoke. Each bushing should seat with an interference fit.
- Measure the distance from the shoulder of the metal insert on the flex bushing to the machined ring face of the yoke. This length should be $1\frac{1}{16}$ " \pm $\frac{1}{32}$ " as shown in Figure 2.
- Replace driveshaft tube assembly and couplings using the installation procedure previously described in this manual.

Balancing

Note

When balancing driveshaft on the tower, do not exceed 30 sec/hour total motor starting time—motor may become overheated.

Balancing should be performed by an experienced service contractor or technician.

SPX COOLING TECH, LLC

7401 WEST 129 STREET
OVERLAND PARK, KS 66213 USA
913 664 7400 | spxcooling@spx.com
spxcooling.com

Z0440323 B | ISSUED 5/2026

©2016-2026 SPX COOLING TECH, LLC | ALL RIGHTS RESERVED

In the interest of technological progress, all products are subject to design and/or material change without notice.

