

AV cooling tower

INSTALLATION - OPERATION - MAINTENANCE

Z0479216_C ISSUED 8/2017

READ AND UNDERSTAND THIS MANUAL PRIOR TO OPERATING OR SERVICING THIS PRODUCT

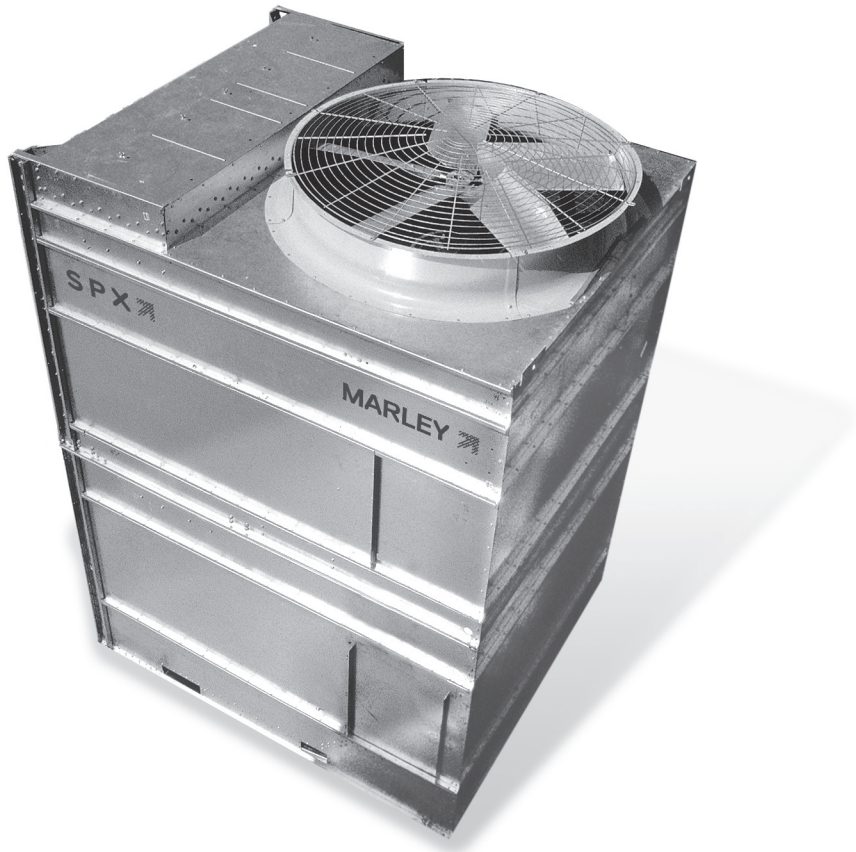

contents

Note

This manual contains vital information for the proper installation and operation of your cooling tower. Carefully read the manual before installation or operation of the tower and follow all instructions. Save this manual for future reference.

Overview.....	3
Tower Location	4
Tower Shipment.....	5
Receiving Tower	5
Hoisting Tower.....	5
Tower Installation.....	6
Tower Start-Up	12
Tower Operation.....	14
Wintertime Operation.....	16
Tower Cleaning, Water Treatment and Blowdown.....	19
Belt Tensioning	21
Sheave Alignment.....	22
Schedule of Tower Maintenance	23
Seasonal Shutdown Instructions	25
Prolonged Shutdown	26
Maintenance Schedule.....	27
Troubleshooting.....	28
Additional Information	30

The following defined terms are used throughout this manual to bring attention to the presence of hazards of various risk levels, or to important information concerning the life of the product.

⚠ Warning

Indicates presence of a hazard which can cause severe personal injury, death or substantial property damage if ignored.

⚠ Caution

Indicates presence of a hazard which will or can cause personal injury or property damage if ignored.

Note

Indicates special instructions on installation, operation or maintenance which are important but not related to personal injury hazards.

overview

This User Manual as well as those offered separately on motors, fans, Geareducer, couplings, drive shafts, float valves, pumps, etc., are intended to assure that this cooling tower serves you properly for the maximum possible time. Since product warrantability may well depend upon your actions, please read this User Manual thoroughly prior to operation.

This User Manual provides information regarding general cooling tower installation and operation. Any deviation from, change or modification to, the User Manual, the original design conditions or the original intended use of the equipment may result in improper installation and/or operation of the tower.

Any such deviation, change or modification shall be the responsibility of the party or parties making such deviation, change or modification. SPX Cooling Technologies, Inc. expressly disclaims all liability for any such deviation, change or modification. The equipment shall be warranted in accordance with the applicable SPX Cooling Technologies Certification of Limited Warranty.

If you have questions about the operation and/or maintenance of this cooling tower, and you don't find the answers in this manual, please contact your Marley sales representative. When writing for information, or when ordering parts, please include the serial number shown on the cooling tower nameplate.

Safety First

The location and orientation of the cooling tower can affect the safety of those responsible for installing, operating or maintaining the tower. However, since SPX Cooling Technologies does not determine the location or orientation of the tower, we cannot be responsible for addressing those safety issues that are affected by the tower's location or orientation.

Warning

The following safety issues should be considered by those responsible for designing the tower installation.

- ***access to and from maintenance access doors***
- ***the possible need for ladders (either portable or permanent) to gain access to the distribution basin or maintenance access doors***
- ***the possible need for distribution basin platforms***
- ***access issues due to obstructions surrounding the tower***
- ***lockout of mechanical equipment***
- ***the possible need for safety cages around ladders***
- ***the need to avoid exposing maintenance personnel to the potentially unsafe environment inside the tower.***



overview

Note

It is not intended nor assumed that access to the fan deck is needed or necessary.

Those are only some of the safety issues that may arise in the design process. SPX strongly recommends that you consult a safety engineer to be sure that all safety considerations have been addressed.

Several options are available that may assist you in addressing some of these personnel safety concerns, including:

- distribution basin access platform with ladder and handrail
- ladder extensions for distribution basin platform ladders (used where the base of the tower is elevated)
- safety cages for distribution basin platform ladders
- mechanical equipment access platform and ladder
- fan cylinder extensions
- flow control valve

Tower Location

Space available around the tower should be as generous as possible to promote ease of maintenance—and to permit freedom of airflow into and through the tower. If you have questions about the adequacy of the available space and the intended configuration of the tower, please contact your Marley sales representative for guidance.

Prepare a stable, level support foundation for the tower, utilizing weight, wind load, and dimensional information appearing on appropriate Marley submittal drawings. Supports must be level to insure proper operation of the tower.

⚠ Warning

The cooling tower must be located at such distance and direction to avoid the possibility of contaminated tower discharge air being drawn into building fresh air intake ducts. The purchaser should obtain the services of a Licensed Professional Engineer or Registered Architect to certify that the location of the tower is in compliance with applicable air pollution, fire, and clean air codes.

receiving and hoisting

Tower Shipment

Unless otherwise specified, AV Series towers ship by truck (on flat bed trailers), which lets you receive, hoist, and install the tower in one continuous operation. Single-cell towers ship on one truck. Multicell towers, depending on their size, may require more than one truck.

Responsibility for the condition of the tower upon its arrival belongs to the trucker—as does the coordination of multiple shipments, if required.

Receiving Tower

Prior to unloading the tower from the delivering carrier, inspect the shipment for evidence of damage in transit. If damage is apparent, note the freight bill accordingly. This will be needed to support any future recovery claim.

Find and remove the installation instruction drawings and bills of material (literature kit) located in a plastic bag in the cold water basin. This information should be kept for future reference and maintenance purposes.

Hoisting Tower

AV6300 through AV6700 models consist of two modules per cell. The upper module includes hoisting clips at the top of the module. The hoisting clips on the lower module are located near the bottom on the ends of the cold water basin. All other models ship in a single module. The hoisting clips for the single height models, AV6100 and AV6200, are located at the top of the tower. A **Hoisting-Installation** label is located on the side casing near the access door and on a drawing in the literature kit. Remove tower from the carrier and hoist into place according to the instructions on the label or on the drawing.

⚠ Warning

Hoisting clips are provided for ease of unloading and positioning tower. For overhead lifts or where additional safety is required, safety slings should also be placed under the tower. Under no circumstances should you combine the top and bottom modules of AV6300 through AV6700 models and attempt to hoist them at the same time by utilizing the hoisting clips alone!

installation

Tower Installation

Note

These installation instructions are intended to help you prepare before your tower arrives. If discrepancies exist between these instructions and those shipped with the tower, the instructions shipped with the tower will govern.

1. Prior to placement of the tower, confirm that the supporting platform is level, and that the anchor bolt holes are correctly located in accordance with Marley drawings.
2. Place tower (or bottom module of AV6300 through AV6700) on your prepared supports, aligning anchor bolt holes with those in your supporting steel. Make sure that the orientation agrees with your intended piping arrangement. Attach tower to supporting steel with four ½" (13 mm) diameter bolts and flat washers (by others). Position flat washers between the bolt head and the tower basin flange.

Note

Remove the sheet metal fill protector shields from the bottom of the top module before setting in place.

3. **AV6300 through AV6700 models only.** Remove shipping guards from bottom of top module (AV6500 thru AV6700). Clean any debris from the underside of the top module fill, skid and beams and from the top of the bottom module before hoisting into place.

Note

Remove paper backing form sealer strips around top perimeter of bottom module.

Place top module on the top peripheral bearing surface (factory-installed gasket) of bottom module, aligning mating holes as it is set in place. Attach top module to bottom module with fasteners provided—according to Field Installation Manual instructions.

If tower purchased is one cell only, ignore steps 4 through 8.

4. If collection basins are to be equalized by the use of Marley standard flumes, unbolt the temporary coverplate from the basin of the cell just installed. The coverplate is located on the basin side.
5. Unbolt temporary coverplate from the basin of the 2nd cell and set 2nd cell (or bottom module of 2nd cell) in place. Align anchor bolt holes and flume openings in basin sides.
6. Install flume according to **Field Installation Manual** instructions.

installation

Note

It is important that the cells be firmly anchored and aligned before the flume is attached to the 2nd cell.

7. Repeat steps 2 and 3 for 2nd top section on AV63000 thru AV67000 models.
8. Repeat steps 4 through 7 for any remaining cells.
9. Attach your cold water supply piping to the cold water basin outlet connection in accordance with drawing instructions, and utilizing gaskets provided by Marley.

⚠ Caution

Do not support your pipe from the tower or outlet connection—support it externally.

Normally, one of the following three outlet arrangements is provided:

Cased face or air inlet face suction connection: This is a factory-installed, galvanized pipe nipple, extending horizontally from the side, or end of the cold water basin. It is both beveled for welding—and grooved for a mechanical coupling. If a weld connection is used, it is recommended that the weld area be protected against corrosion. Cold galvanizing is suggested, applied according to the manufacturer's instructions.

Bottom outlet connection: This is a factory-installed, screened circular opening in the cold water basin floor of one or more cells. An appropriately-sized circular opening has been drilled to accept a 125# ANSI B16.1 flat-face flange connection.

10. Attach makeup water supply piping to the float valve connection located at the air inlet face of the tower. If you wish to pipe overflow and drain water to a remote discharge point, make those connections at this time.
11. Attach your warm water return piping to the inlet connections of the tower.

⚠ Caution

Do not support your pipe from the tower or inlet connection—support it externally.

Normally, one of the following two inlet arrangements is provided:

Standard distribution basin connections: There is a circular opening in the top deck of the tower near the air inlet face, drilled to accept



installation

standard 125# flat-face flange. Remove the center inlet flume assembly to gain access to attach inlet fasteners. (Refer to the AV Field Installation Manual shipped with tower.)

Marley flow-control valve connection (option): The Marley flow-control valve is designed to 1–take the place of a standard elbow normally required for inlet connection, and 2–provide means of regulating flow between individual cells. Remove the center inlet flume assembly to gain access for attachment of valve. (Refer to the AV Field Installation Manual shipped with tower.) The valves provides a vertical face for attachment of your standard 125# flange.

12. Wire motor in accordance with wiring diagram on motor nameplate. Check motor connections and power supply voltage versus motor nameplate voltage.

⚠ Warning

For maintenance/safety purposes, SPX Cooling recommends a lockout type disconnect switch for all mechanical equipment.

In addition to a disconnect switch, the motor should be wired to main power supply through short circuit protection, and a magnetic starter with overload protection.

Motor Wiring

Wire motor leads as shown on the motor nameplate matching the supply voltage. Do not deviate from the motor nameplate wiring.

Internal space heaters may be present, depending upon the motor manufacturer. For space heater operation and wiring refer to the Marley **“Fan Motor”** User Manual Z0239042.

Either of following symbols may be shown on the motor nameplate – Δ , $\Delta \Delta$, Y, or YY. These symbols represent how the motor is constructed on the inside and in no way have anything to do with a Delta or Wye electrical distribution system serving the motor.

When using a starter:

- Set motor overload protection to 110% of motor nameplate amps. This setting allows the fan motor to operate during cooler weather. During cooler weather it is common for the motor to draw 6 to 10% higher than

installation

nameplate amps. High amps are common during tower commissioning when the tower is dry and the ambient air temperature is cool.

Note

Do not start the motor more than four to five times per hour. Short cycling the tower will cause fuses, breakers or O.L.s to operate and will decrease motor life.

When using a two-speed starter:

- Motor rotation must be the same at slow speed and high speed.
- Single winding motor requires a starter with a shorting contactor.
- Two-winding motor requires a starter with out a shorting contactor.
- All two-speed starters must have a 20 second time delay relay when switching from high speed to low speed.

Note

Do not start the motor more than four to five times per hour (each low speed start and each high speed start count as one start).

When using a VFD:

Note

Before beginning, ensure that the motor is rated for “Inverter Duty” per NEMA MG-1, part 31.

- Set the VFD solid state overload protection to 119% of motor nameplate amps and set “maximum current parameter” in the VFD to motor nameplate amps. “Maximum current parameter” will reduce fan speed and limit amp draw to nameplate amps during cold weather operation. If furnished with a mechanical O.L. set this at 110% over motor nameplate amps.
- Motor rotation must be the same in both VFD mode and By-pass mode.
- If cable distance between the VFD and motor is greater than 100 feet a DV/DT output filter is recommended to avoid damage to the motor. 100 feet distance is based on our field experience, the VFD manufacture may state different distances and distance does vary depending on the VFD manufacture.
- Program the VFD for variable torque output. Flux vector and constant torque modes may damage the gearbox.
- Do not start and stop the motor using the safety switch at the motor. If the drive is being commanded to run and the load side is cycled ON and OFF with the safety switch this may damage the VFD.



installation

Using a VFD in cooling applications has advantages over traditional single or two speed motor control. A VFD can reduce the cost of electrical energy being used and provide better temperature control. In addition, it reduces the mechanical and electrical stress on the motor and mechanical equipment. Electrical savings can be large during periods of low ambient temperature when the cooling requirement can be satisfied at reduced speeds. To benefit from these advantages, it is important that the drive be installed correctly.

Marley supplies VFD and VFD controls specifically designed for our cooling products. If you have purchased a Marley VFD and/or controls package, please follow the instructions in the *User Manual* for that system. Most VFD problems can be avoided by purchasing the Marley drive system. If you are installing a VFD other than the Marley drive, please refer to that drives installation manual.

⚠ Warning

Improper use of a VFD may cause damage to equipment or personal injury. Failure to correctly install the VFD drive will automatically void all warranties associated with the motor and any equipment that is either electrically or mechanically (directly) attached to the VFD drive system. The length of this warranty avoidance will be contingent on properly installing the VFD system and repairing any damage that may have occurred during its operation. SPX Cooling Technologies does not assume responsibility for any technical support or damages for problems associate with non-Marley brand VFD systems.

⚠ Warning

Changing the operational fan speed from the factory settings could cause the fan to operate in an unstable region which may result in damage to the equipment and possible injury.

Mechanical Equipment:

⚠ Warning

Always shut off electrical power to the tower fan motor prior to performing any maintenance on the tower. Any electrical switches should be locked out and tagged out to prevent others from turning the power back on.

1. Install AV61000 and AV62000 fan guard according to the installation drawing shipped with the tower. The fan guard on other models is factory installed.
2. Spin the fan manually to assure that all fan blades properly clear the inside of the fan cylinder. Observe the action of the sheaves and belt(s) to be

installation

sure that the motor is properly aligned with the fan sheave. If necessary, correct the alignment. See the Maintenance section for belt tensioning and sheave alignment—page 22.

⚠ Warning

Improper installation of the fan guard will destroy the structural integrity of the fan guard. It is essential that the fan guard be installed in accordance with the Field Installation Manual shipped with the tower. Do not force the fan cylinder out of round.

3. Momentarily energize (“bump”) the motor and observe rotation of the fan. The fan should rotate in a counterclockwise direction when viewed from below. If rotation is backwards, shut off the fan and reverse two of the three primary leads supplying power to the motor.

⚠ Caution

If tower is equipped with a two-speed motor, check for proper rotation at both speeds. Check also to see that starter is equipped with a 20 second time delay which prevents direct switching from high speed to low speed. If the fan is intended to be reversed for deicing purposes, make sure that the starter is equipped with a 2 minute time delay between changes of direction. These delays will prevent abnormal stress from being applied to the mechanical equipment and the electrical circuit components.

4. Run the motor and observe the operation of the mechanical equipment. Operation should be stable.
5. After the first 30 minute run check motor AMPS and voltage with full water and heat load. Repitch fan, if necessary—correct for low ambient temperatures. Refer to motor manual.
6. After 10 to 60 hours of operation check the torque on the fan and motor sheave bushings and check belt tension. Refer to the Maintenance section of this manual for torque values and belt tensioning instructions—page 22.

Note

If the water supply system is not being operated—or if there is no heat load on the system—motor amps read at this time may indicate an apparent overload of as much as 10–20%. This is because of the increased density of unheated air flowing through the fan. Determination of an accurate motor load should await the application of the design heat load.

operation

⚠ Warning

Tower Start-Up

Among other sources, outbreaks of Legionnaires' Disease have reportedly been traced to cooling towers. Maintenance and water treatment procedures that prevent amplification and dissemination of Legionella and other airborne bacteria should be formulated and implemented BEFORE systems are operated and continued regularly thereafter to avoid the risk of sickness or death.

Water System:

1. New installations should be cleaned and treated with biocides by a water treatment expert before startup.
2. Remove any and all accumulated debris from tower. Pay particular attention to inside areas of cold water basin, hot water basins, louvers and drift eliminators. Make sure that cold water suction screens are clear and properly installed.
3. Fill the water system to an approximate depth of 7½" (192 mm) in the depressed area of the cold water basin at the air inlet side of the tower. This is the recommended operating water level. Adjust the float valve so that it is 75% open at that level. Continue filling the system until the water reaches a level approximately ⅛" (3 mm) below the lip of the overflow.

Note

If tower is equipped with a standard suction connection, vent accumulated air from the top of the suction hood by removing one or both tap screws provided at that location. Replace these tap screws when venting is complete.

4. Completely open hot water flow control valve(s). Start your pump(s) and observe system operation. Since the water system external to the tower will have been filled only to the level achieved in the cold water basin, a certain amount of "pump-down" of the basin water level will occur before water completes the circuit and begins to fall from the fill. The amount of initial pump-down may be insufficient to cause the float valve to open. However, you can check its operation by pressing down on the operating lever to which the stem of the float valve is attached.

operation

Some trial-and-error adjustment of the float valve may be required to balance the makeup water with tower operation. Ideally, the float valve setting will be such that no water is wasted through the overflow at pump shutdown. However, the water level after pump start-up **must** be deep enough to assure positive pump suction.

5. If a multicell tower installation is equipped with flow-control valves, adjust them to equalize hot water depth in the distribution basins after reaching design water flow rate. Each basin should have from 2¾" to 5½" (70 mm to 140 mm) water depth, with uniform depth from basin to basin. Fix valves in this position when depth is correct. If the tower is a single cell installation this step is not necessary.

Uniform distribution depth of 2¾" to 5½" (70 mm to 140 mm) is essential to efficient tower operation. Contact your Marley sales representative if you are considering a permanent change in circulating water flow rate that would prevent operation within these limits.

6. Continue pump operation for about 15 minutes, after which it is recommended that the water system be drained, flushed, and refilled.
7. While operating the condensing water pump(s) and prior to operating the cooling tower fan, execute one of the two alternative biocidal treatment programs described in the following:

- Resume treatment with the biocide which had been used prior to shutdown. Utilize the services of the water treatment supplier. Maintain the maximum recommended biocide residual (for the specific biocide) for a sufficient period of time (residual and time will vary with the biocide) to bring the system under good biological control

or

- Treat the system with sodium hypochlorite to a level of 4 to 5 mg/L (ppm) free chlorine residual at a pH of 7.0 to 7.6. The chlorine residual must be held at 4 to 5 mg/L (ppm) for six hours, measurable with standard commercial water test kits.

If the cooling tower has been in operation and then shut down for a duration of time and not drained, perform one of the two previous biocidal treatment programs directly to the cooling water storage vessel (cooling tower sump, drain down tank, etc.) without circulating stagnant water over the cooling tower fill or operating the cooling tower fan. After biocidal pretreatment has been successfully completed, cooling water may be circulated over the tower fill with the fan off.



operation

When biocidal treatment has been maintained at a satisfactory level for at least six hours, the fan may be turned on and the system returned to service. Resume the standard water treatment program, including biocidal treatment.

Tower Operation

General:

The cold water temperature obtained from an operating cooling tower will vary with the following influences:

1. **Heat load:** With the fan in full operation, if the heat load increases, the cold water temperature will rise. If the heat load reduces, the cold water temperature will reduce.

Note that the number of degrees ("range") through which the tower cools the water is established by the system heat load and the amount of water being circulated, in accordance with the following formula:

$$\text{Range} - ^\circ\text{F} = \frac{\text{Heat Load (Btu/hr)}}{\text{gpm} \times 500}$$

The cooling tower establishes only the cold water temperature attainable under any operating circumstance.

2. **Air wet-bulb temperature:** Cold water temperature will also vary with the wet-bulb temperature of the air entering the louvered faces of the tower. Reduced wet-bulb temperatures will result in colder water temperatures. However, the cold water temperature will not vary to the same extent as the wet-bulb. For example, a 20°F (11 °C) reduction in wet-bulb may result in only a 15°F (8°C) reduction in cold water temperature.
3. **Water flow rate:** Increasing the water flow rate (GPM or L/s) will cause a slight elevation in cold water temperature, while reducing the water flow rate will cause the cold water temperature to decrease slightly. However, at a given heat load (see formula above), water flow reductions also cause an increase in the incoming hot water temperature. Use care to prevent the hot water from exceeding 125°F, (52°C) in order to prevent damage to the tower components.

operation

4. **Air flow rate:** Reducing air flow through the tower causes the cold water temperature to rise. This is the approved method by which to control leaving water temperature.

If your tower is equipped with a single-speed motor, the motor may be shut off when the water temperature becomes too cold. This will cause the water temperature to rise. When the water temperature then becomes too warm for your process, the motor can be restarted.

Fan cycling limits:

Note

Considering the normal fan and motor sizes utilized on AV towers, anticipate that approximately 4 to 5 starts per hour are allowable.

If your tower is equipped with a two-speed motor, you will enjoy greater opportunity for temperature control. When the water temperature becomes too cold, switching the fan to half-speed will cause the cold water temperature to rise—stabilizing at a temperature a few degrees higher than before. With a further reduction in water temperature, the fan may be cycled alternately from half-speed to off.

Note

Do not start the motor more than four to five times per hour (each low speed start and each high speed start count as one start).

If your tower consists of two or more cells, cycling of motors may be shared between cells, increasing your steps of operation accordingly.

For greater insight on cold water temperature control, please read “**Cooling Tower Energy and its Management**”, *Marley Technical Report H-001*, available at spxcooling.com.

operation

Wintertime Operation:

The Marley fill system used in the AV Series cooling tower has air entrance louvers that are molded integrally as part of the fill. This feature makes these towers very forgiving of cold weather operation, even at the low temperature and reduced load conditions encountered in free cooling and other low temperature applications. Nevertheless, during operation in subfreezing weather the opportunity exists for ice to form in the colder regions of the tower.

Note

Slushy, transitory ice forms routinely in the colder regions of the fill of low temperature towers, and is visible through the tower louvers. Such ice normally has no adverse effect on tower operation, but its appearance should be a signal to the operator to undertake ice control procedures.

It is the operator's responsibility to prevent the formation of destructive (hard) ice on the cooling tower fill. Certain guidelines should be followed:

1. Do not allow the tower's leaving water temperature to drop below a minimum allowable level—say 36°F to 40°F (2°C to 4.5°C). If such low temperature operation is necessary or beneficial to your process, establish the minimum allowable level as follows:

During the coldest days of the first winter of operation, observe whether any ice is forming on the louver face, particularly near the bottom part of the louver face. If hard ice is present on the louvers, you must increase the allowable cold water temperature. If the coldest possible water is beneficial to your process, ice of a mushy consistency can be tolerated—but routine periodic observation is advisable.

⚠ Caution

If the minimum allowable cold water temperature is established at or near minimum heat load, it should be safe for all operating conditions.

Having established the minimum allowable cold water temperature, maintaining that temperature can be accomplished by fan manipulation, as outlined in **Item 4** under **Tower Operation**. However, in towers of more than one cell, where fans are manipulated sequentially, please realize that the water tem-

operation

perature will be significantly lower in the cell or cells operating at the highest fan speed than the net cold water temperature produced by the entire tower would indicate. Wintertime operation of multicell towers at low cold water temperature levels requires that the operator be especially watchful.

2. As cold air enters the louvers, it causes the water flowing over the fill to be drawn inward toward the center of the tower. Thus, under fan operation, the louvers and lower periphery of the tower structure remain partly dry, seeing only random splashing from within the tower—plus normal atmospheric moisture from the entering air. Such lightly wetted areas are most subject to freezing.

Therefore, if excessive ice forms on the louvers, stop the fan for a few minutes. With the fan off, the water flow will increase in the vicinity of the louvers and reduce the ice buildup.

3. Under extended extreme cold conditions, it may be necessary to operate the fan in reverse. This forces warm air out through the louvers, melting any accumulated ice—adequate heat load must be available. Reversal of fan should only be done at **half speed** or less. Reverse operation of the fan should be used sparingly and should only be used to control ice, **not** to prevent it. Reverse fan operation should not need to exceed 1 or 2 minutes. Monitoring is required to determine the time required to melt accumulated ice.

Warning

Operating the fan in reverse at half speed for prolonged periods during subfreezing weather can cause severe damage to fans and fan cylinders. Ice can accumulate inside fan cylinders at fan blade plane of rotation and fan blade tips will eventually strike this ring of ice, damaging the fan blades or cylinder. Ice can also accumulate on fan blades and be thrown off, damaging fan cylinder or blades. Allow a minimum of 10 minute delay between reverse operation and forward operation during subfreezing weather to permit ice to dissipate from fan blades and fan cylinders. See Caution note on page 11 for fan speed change and reversing precautions.



operation

4. With no heat load on the circulating water, icing cannot be controlled effectively by air control during freezing weather. **Towers must not be operated with reduced water rate and/or no heat load during freezing weather.** If the circulating water system cannot be shut down, water returning from the process should be made to bypass the tower. If a bypass is used, **all** water must be bypassed without modulation. If the water bypass is directly into the tower's cold water basin, its design must be approved by SPX Cooling engineers.

Intermittent Wintertime Operation:

If periods of shutdown (nights, weekends, etc.) occur during freezing weather, measures must be taken to prevent the water in the cold water basin—and all exposed pipework—from freezing. Several methods are used to combat this, including Marley automatic basin heater systems.

⚠ Caution

Unless some means of freeze prevention is incorporated into your system, the tower basin and exposed pipework should be drained at the beginning of each wintertime shutdown period.

⚠ Warning

If tower basin is drained, verify that all basin heaters have been shut off either by automatic cutoff or disconnect switch.

It is recommended that you discuss your freeze prevention options with your local Marley sales representative.

operation

Tower Cleaning, Water Treatment and Blowdown

Maintaining Water Quality:

The steel used in AV Series towers has been galvanized with a heavy zinc coating averaging 2.0 mils in thickness. AV Series towers are also available in stainless steel, which is even more corrosion resistant than galvanized steel in certain environments. Other materials used (PVC fill, drift eliminators, and louvers, aluminum fans, etc.) are selected to offer maximum service life in a “normal” cooling tower environment, defined as follows:

Circulating water with a pH between 6.5 and 8; a chloride content (as NaCl) below 500 ppm; a sulfate content (SO_4) below 250 ppm; total alkalinity (as CaCO_3) below 500 ppm; calcium hardness (as CaCO_3) above 50 ppm; a maximum inlet water temperature not to exceed 125°F (51.7°C); no significant contamination with unusual chemicals or foreign substances; and adequate water treatment to minimize scaling.

- Startup Conditions: The water conditions during the initial tower operation are crucial in preventing premature corrosion of galvanized steel (white rust). For at least the first eight weeks of operation, pH should be controlled between 6.5 and 8.0 with hardness and alkalinity levels between 100 and 300 ppm (expressed as CaCO_3).
- Chlorine (if used) shall be added intermittently, with a free residual not to exceed 1 ppm—maintained for short periods. Excessive chlorine levels may deteriorate sealants and other materials of construction.
- An atmosphere surrounding the tower no worse than “moderate industrial”, where rainfall and fog are no more than slightly acid, and they do not contain significant chlorides or hydrogen sulfide (H_2S).
- Many proprietary chemicals exist for control of scale, corrosion, and biological growth and should be used prudently. Also, combinations of chemicals may cause reactions which reduce treatment effectiveness, and certain chemicals such as surfactants, biodispersants and antifoams may increase drift rate.

⚠ Warning

Unless you purchased a stainless steel AV Series the structure of your AV Series consists primarily of galvanized steel, therefore your water treatment program must be compatible with zinc. In working with your water treatment supplier, it is important that you recognize the potential effects on zinc of the specific treatment program you choose.

maintenance

Cooling Tower Cleaning:

⚠ Warning

Any evaporative-type cooling tower must be thoroughly cleaned on a regular basis to minimize the growth of bacteria, including *Legionella Pneumophila*, to avoid the risk of sickness or death. Service personnel must wear proper personal protective equipment during decontamination. Do NOT attempt any service unless the fan motor is locked out.

Operators of evaporative cooling equipment, such as water cooling towers, should follow maintenance programs which will reduce to an absolute minimum the opportunity for bacteriological contamination. Public Health Service officials have recommended that “good housekeeping” procedures be followed, such as: regular inspections for concentrations of dirt, scale, and algae; periodic flushing and cleaning; and the following of a complete water treatment program including biocidal treatment. See **Tower Startup** instructions on page 12.

The visual inspection should take place at least once a week during the operating season. The periodic flushing and cleaning should be done before and after each cooling season, but in any event at least twice a year. The louvers, drift eliminators, and easily accessible fill surfaces should be flushed by use of a moderate-pressure water nozzle, being careful not to cause physical damage. A reliable water treatment program should be installed and maintained. Filtration devices may be employed to reduce the suspended solids concentrations, thus increasing the effectiveness of the water treatment program. See **Tower Startup** instructions on page 12.

Blowdown:

A cooling tower cools water by continuously causing a portion of it to evaporate. Although the water lost by evaporation is replenished by the makeup system, it exits the tower as pure water—leaving behind its burden of dissolved solids to concentrate in the remaining water. Given no means of control, this increasing concentration of contaminants can reach a very high level.

In order to achieve water quality which is acceptable to the cooling tower (as well as the remainder of your circulating water system), the selected water treatment company must work from a relatively constant level of concentrations. This stabilization of contaminant concentrations is usually accomplished by blowdown, which is the constant discharge of a portion of the circulating water to waste. As a rule, acceptable levels on which to base a treatment schedule will be in the

maintenance

range of 2-4 concentrations. The following table shows the minimum amount of blowdown (percent of flow) required to maintain different concentrations with various cooling ranges*:

Cooling Range	Number of Concentrations						
	1.5X	2.0X	2.5X	3.0X	4.0X	5.0X	6.0X
2.78° C	.7	.38	.25	.18	.11	.08	.06
5.56° C	1.58	.78	.51	.38	.25	.18	.14
8.33° C	2.38	1.18	.78	.58	.38	.28	.22
11.11° C	3.18	1.58	1.05	.78	.51	.38	.30
13.89° C	3.98	1.98	1.32	.98	.64	.48	.38
Multipliers are based on drift of 0.02% of the circulating water rate.							

* Range = Difference between hot water temperature coming to tower and cold water temperature leaving tower.

EXAMPLE: 700 gpm circulating rate, 18°F cooling range. To maintain 4 concentrations, the required blowdown is 0.458% or .00458 times 700 gpm, which is 3.2 gpm.

If tower is operated at 4 concentrations, circulating water will contain four times as much dissolved solid as the makeup water, assuming none of the solids form scale or are otherwise removed from the system.

Note

When water treatment chemicals are added, they should not be introduced into the circulating water system via the cold water basin of the cooling tower. Water velocities are lowest at that point, which results in inadequate mixing.

Belt Tensioning

The belts are adjusted by turning the jacking screw at the motor support. Ideal tension is the lowest tension at which the belt will not slip under peak load conditions. Check tension frequently during the first 24-48 hours of run-in operation. Overtensioning shortens belt and bearing life. Keep belts free from foreign material which may cause slip. Never apply belt dressing as this will damage the belt and cause early failure. A Dodge® V-Belt Tension Tester is an alternate method for tensioning V-belts. Check with you local belt supplier.



maintenance

Sheave Alignment

- The motor sheave is to be positioned as close as possible to the motor in order to minimize torque on the motor bushings.
- The motor and fan sheaves may have grooves that are not used. The bottom surface of the motor and fan sheaves must be aligned within $\frac{1}{8}$ " of each other and level within $\frac{1}{2}^\circ$ ($\frac{1}{8}$ " in 12) in order to not adversely affect belt and sheave life.
- Alignment can be achieved by placing a straight edge across the top of the sheaves making sure that it is level and measuring down to the bottom surface of both sheaves at four points.
- The belt is to be located in the lowest set of grooves.

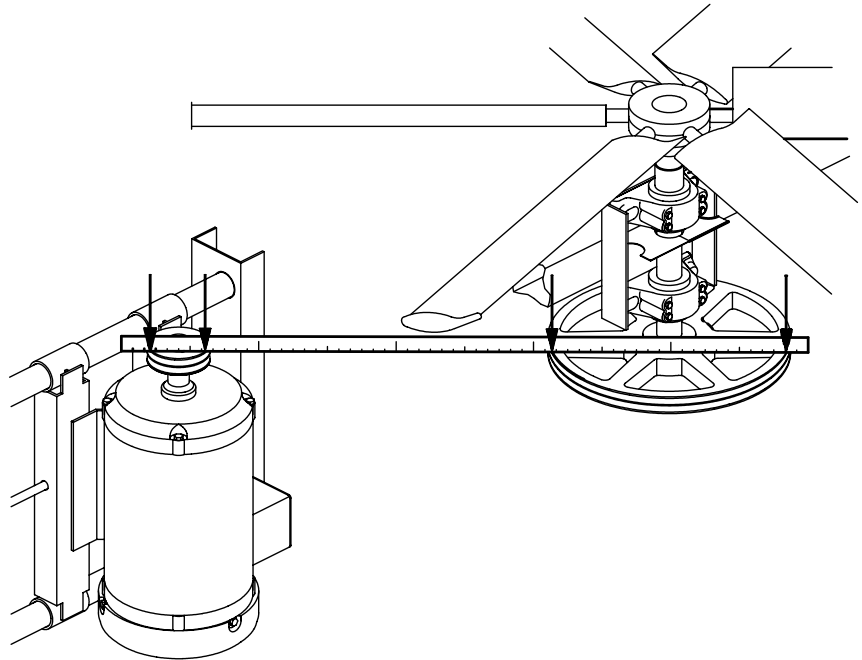

Bushing	Fastener Size	Torque	
		ft·lb _f	N·m
SH	$\frac{1}{4}$ - 20	6	8
SDS	$\frac{1}{4}$ - 20	6	8
SD	$\frac{1}{4}$ - 20	6	8
SK	$\frac{5}{16}$ - 18	13	18
SF	$\frac{3}{8}$ - 16	22	30
E	$\frac{1}{2}$ - 13	35	48
F	$\frac{9}{16}$ - 12	65	88

Bushing Fastener Torque Values

maintenance

Schedule of Tower Maintenance

Some maintenance procedures may require maintenance personnel to enter the tower. Each cased face of the tower has a door for access to the interior of the tower. All AV Series have a 30" wide by 42" high door opening.

The purchaser or owner is responsible for providing a safe method for entering or exiting the access door. Protective clothing to avoid cuts from sheet metal should be worn. Wet sheet metal an/or dirt can be slippery. Nonlip sole shoes should also be worn.

Included with this instruction packet are separate User Manuals on each major operating component of the tower, and it is recommended that you read them thoroughly. Where discrepancies may exist, the separate User Manuals will take precedence.

The following is recommended as a minimum routine of scheduled maintenance:

⚠ Warning

Always shut off electrical power to the tower fan motor prior to performing any inspections that may involve physical contact with the mechanical or electrical equipment in or on the tower. Lock out and tag out any electrical switches to prevent others from turning the power back on. Service personnel must wear proper personal protective clothing and equipment.

Weekly: Inspect for bacterial growth and general operation conditions. Bacterial growth should be reported to your water treatment expert for immediate attention.

Monthly (Weekly at start up): Observe, touch, and listen to the tower. Become accustomed to its normal appearance, sound, and level of vibration. Abnormal aspects relating to the rotating equipment should be considered reason to shut down the tower until the problem can be located and corrected. Observe operation of the motor, sheaves, belt, and fan. Become familiar with the normal operating temperature of the motor, as well as the sight and sound of all components as a whole.

Inspect louvers, drift eliminators and basin trash screens and remove any debris or scale which may have accumulated. Replace any damaged or worn out components. Use of high-pressure water may damage the eliminator and louver material.



maintenance

Observe operation of the float valve. Depress the operating lever to make sure that the valve is operating freely. Inspect the suction screen for plugging. Remove any debris that may have accumulated.

Check for any buildup of silt on the floor of the cold water basin. Mentally make note of the amount, if any, so future inspections will enable you to determine the rate at which it is forming.

Every 3 months: Lubricate fan shaft bearings. While rotating equipment by hand, grease the bearings until a bead forms around the seals—a maximum charge of 0.55 ounces is recommended. Chevron SRI-2 grease is recommended.

Every 6 months: Check belt tension and condition.

Check makeup float valve seals—replace as required.

If equipped with inlet flow control valve, grease valve stem guide—fully open and close—return to original position and lock.

Clean and disinfect cooling tower with biocides. Systems with biofouling, high general bacterial counts, or positive cultures of legionella may require additional cleaning. Refer to **Cooling Tower Cleaning** section on page 19. Consult your water treatment expert as to prudent biological evaluation testing.

If basin silt level is significant, drain the basin and clean it out. Refer to **Cooling Tower Cleaning** section on page 19.

Annually: Lubricate fan motor. Refer to motor manufacturer's recommendations. Remove grease fill and relief plugs from front of motor and remove hardened grease with a wire or similar item. Add grease until grease is forced out at relief hole. Replace fill plug, run ½ to 1 hour and replace relief plug. Fan motors with sealed bearings do not require lubrication maintenance.

Check to see that all bolts are tight in the fan and mechanical equipment region, including the fan cylinder and fan guard. Use torque settings prescribed in the fan manual.

Inspect the tower thoroughly, making maximum use of instructions given in the separate service manuals. Check structural bolted connections and tighten as required. Make preventive maintenance repairs as necessary.

Note

If the motor has sealed bearings, additional lubrication is not required. Refer to the motor nameplate to determine if grease type and amount are specified.

maintenance

Seasonal Shutdown Instructions

When the system is to be shut down for an extended period of time, it is recommended that the entire system (cooling tower, system piping, heat exchangers, etc.) be drained. Leave the basin drains open.

During shutdown, clean the tower (see Warning, page 20) and make any necessary repairs. Pay particular attention to mechanical equipment.

Following each year's shutdown and cleaning, inspect the tower's metal surfaces for evidence of the need to apply a protective coating. Do not misinterpret grime—and transient rust from the piping system—as a need to have the tower painted. If relatively bright metal can be exposed by cleaning, consider that the galvanizing has remained effective. Unless there is evidence of a generalized failure of the galvanizing, localized touch-up should be all that is required.

To the extent that the galvanizing (zinc coating) still exists, paint will not adhere to it readily. Contact the manufacturer of the coating you intend to use for instructions.

Tower framework: Check structural bolted connections and tighten as required.

Fans: Check fan assembly bolting and tighten as required. Use torque settings prescribed in the fan manual.

Fiberglass Components: Check all fiberglass parts for exposed glass fibers. If found, the affected surfaces should be recoated using a two-part polyamide epoxy primer to promote adhesion and a two-part acrylic polyurethane enamel for the topcoat.

Fan shaft bearings: Lubricate fan shaft bearings at close of each operating season—see page 24.

Fan motors: Clean and lubricate motor at close of each operating season (refer to motor manufacturer's recommendations.) Does not apply to motors with sealed bearings. Check motor anchor bolts and tighten as required.

Do not start motor before determining that there will be no interference with free rotation of the fan drive.

The motor should be operated for three hours at least once a month. This serves to dry out windings and lubricate bearing surfaces—refer to Marley “Fan Motor” User Manual Z0239042 for additional information.

At start of new operating season, make sure bearings are adequately lubricated before returning motor to service. Does not apply to motors with sealed bearings.

maintenance

Prolonged Shutdown

If shutdown period is longer than seasonal, contact your Marley sales representative for additional information.

SPX Cooling Technologies' Services

Our interest in your AV Series cooling tower does not end with the sale. Having conceived, designed, and manufactured the most reliable and longest-lasting cooling tower of its class, we want to make sure that you gain the maximum possible benefit from its purchase.

Therefore, the following services are available which are intended to: assure the maximum possible service life under your operating conditions; tailor the operating characteristics to your specific needs; and maintain consistently optimum thermal performance capability. They are available by contacting your Marley sales representative.

Replacement parts: With the exception of the motor, drive system, and float valve, every standard component of your tower is designed and manufactured by SPX Cooling Technologies. We do this because commercially available components have not proved capable of withstanding the harsh environment of a cooling tower—nor do they contribute their share to the thermal capability and operating characteristics intended.

A complete stock of all parts and components is maintained at one or more of the various Marley plants. In cases of emergency, they can normally be shipped within 24 hours—by air freight if necessary. However, you would obviously benefit from anticipating your need in advance, thus avoiding the cost of special handling.

Be sure to include your tower serial number (from the tower nameplate) when ordering parts.

Periodic maintenance: You may wish to contract with SPX Cooling for regularly scheduled visits—for the purpose of inspecting and reporting your tower's condition—to make recommendations intended to prevent emergencies— and to perform maintenance considered outside the norm.

This service is not intended to replace the important function performed by your maintenance staff. Their attention assures the tower's routine operating performance, and is invaluable. However, we recognize that the unusual manner in which a cooling tower performs its function—as well as the unique forces which act upon it—may be considerations which occasionally require the services of an expert technician.

maintenance schedule

Maintenance Service	Monthly	Semi-annually	Seasonal Startup or Annually
Inspect General Condition and Operation	x		x
Observe Operation of:			
Mechanical—motor, fan and drive mechanism	x		x
Makeup valve (if equipped)	x		x
Inspect for unusual noise or vibration	x		x
Inspect and Clean:			
Air inlet	x		x
PVC drift eliminators	x		x
Distribution basin, nozzles and collection basin	x		x
Fan motor exterior	x		x
Check:			
Collection water basin level	x		x
Blowdown—adjust as required	x		x
Belt drive:			
Fan shaft bearing lubrication (every 3 mo.)		every 3 months	every 3 months
Check and tighten support fasteners			x
Check shaft, sheave and belt alignment			x
Check belt tension and condition		x	x
Check sheave bushing fastener torque			x
Fan:			
Check and tighten blade and hub fasteners			x
Check fan blade pitch and tip clearance			x
Check fan cylinder for loose fasteners			x
Motor:			
Lubricate (as required)			R
Check mounting bolts for tightness			x
Operate at least	3 hours a month	3 hours a month	3 hours a month
Basin Heater (if equipped):			
Check for proper operation of temp/low water level sensor			x
Inspect/clean buildup of contaminant from sensor		x	x
Structure:			
Inspect/tighten all fasteners		x	x
Inspect and touch up all metal surfaces			x

R — Refer to Component User Manual

Note: It is recommended at least weekly, that the general operation and condition be observed. Pay attention to any changes in sound or vibration that may signify a need for closer inspection.

troubleshooting

Trouble	Cause	Remedy
Motor will not start		Check power at starter. Correct any bad connections between the control apparatus and the motor.
	Power not available at motor terminals	Check starter contacts and control circuit. Reset overloads, close contacts, reset tripped switches or replace failed control switches. If power is not on all leads at starter, make sure overload and short circuit devices are in proper condition.
	Wrong connections	Check motor and control connections against wiring diagrams.
	Low voltage	Check nameplate voltage against power supply. Check voltage at motor terminals.
	Open circuit in motor winding	Check stator windings for open circuits.
Unusual motor noise	Fan drive stuck	Disconnect motor from load and check motor and Geareducer for cause of problem.
	Rotor defective	Look for broken bars or rings.
	Motor running single-phase	Stop motor and attempt to start it. Motor will not start if single phased. Check wiring, controls and motor.
	Motor leads connected incorrectly	Check motor connections against wiring diagram on motor.
	Bad bearings	Check lubrication. Replace bad bearings.
	Electrical unbalance	Check voltages and currents of all three lines. Correct if required.
	Air gap not uniform	Check and correct bracket fits or bearing.
Motor runs hot	Rotor unbalance	Rebalance.
	Cooling fan hitting end bell-guard	Reinstall or replace fan
	Wrong voltage or unbalanced voltage	Check voltage and current of all three lines against nameplate values.
	Overload	Check fan blade pitch. See Fan User Manual. Check for drag in fan drivetrain as from damaged bearings.
	Wrong motor RPM	Check nameplate against power supply. Check RPM of motor and gear ratio.
	Bearings over greased	Remove grease reliefs. Run motor up to speed to purge excessive grease. Does not apply to motors with sealed bearings.
	Wrong lubrication in bearings	Change to proper lubricant. See motor manufacturer's instructions.
	One phase open	Stop motor and attempt to start it. Motor will not start if single phased. Check wiring controls and motor
	Poor ventilation	Clean motor and check ventilation openings. Allow ample ventilation around motor.
	Winding fault	Check with Ohmmeter.
	Bent motor shaft	Straighten or replace shaft.
Motor runs hot	Insufficient grease	Remove plugs and regrease bearings. Does not apply to motors with sealed bearings.
	Too frequent starting or speed changes	Limit cumulative acceleration time to a total of 30 seconds per hour. Set on/off or speed change set-points farther apart. Consider installing a Marley VFD for fine temperature control.
	Deterioration of grease or foreign material in grease	Flush bearings and relubricate. Does not apply to motors with sealed bearings.
	Bearings damaged	Replace bearings.

troubleshooting

Trouble	Cause	Remedy
Motor does not come up to speed	Voltage too low at motor terminals because of line drop	Check transformer and setting of taps. Use higher voltage on transformer terminals or reduce loads. Increase wire size or reduce inertia.
	Broken rotor bars	Look for cracks near the rings. A new rotor may be required. Have motor service person check motor.
Wrong motor rotation	Wrong sequence of phases	Switch any two of the three motor leads.
Geareducer noise	Geareducer bearings	If new, see if noise disappears after one week of operation. Drain, flush and refill Geareducer oil. See Geareducer User Manual. If still noisy, replace.
	Gears	Correct tooth engagement. Replace badly worn gears. Replace gears with broken or damaged teeth
Unusual fan drive vibration	Loose bolts and cap screws	Tighten all bolts and cap screws on all mechanical equipment and supports.
	Unbalanced driveshaft or worn couplings	Make sure motor and Geareducer shafts are in proper alignment and "match marks" properly matched. Repair or replace worn couplings. Rebalance driveshaft by adding or removing weights from balancing cap screws. See Driveshaft User Manual.
	Fan	Make certain all blades are as far from center of fan as safety devices permit. All blades must be pitched the same. See Fan User Manual. Clean off deposit build-up on blades
	Worn Geareducer bearings	Check fan and pinion shaft endplay. Replace bearings as necessary.
	Unbalanced motor	Disconnect load and operate motor. If motor still vibrates, rebalance motor.
Fan noise	Bent Geareducer shaft	Check fan and pinion shaft with dial indicator. Replace if necessary.
	Blade rubbing inside of fan cylinder	Adjust cylinder to provide blade tip clearance.
	Loose bolts in blade clamps	Check and tighten if necessary
Scale or foreign substance in circulating water system	Insufficient blowdown	See "Water Treatment" section of this manual.
	Water treatment deficiency	Consult competent water treating specialist. See "Water Treatment" section of this manual.
Cold-water temperature too warm (see "Tower Operation")	Entering wet-bulb temperature is above design	Check to see if local heat sources are affecting tower. See if surrounding structures are causing recirculation of tower discharge air. Discuss remedy with Marley representative.
	Design wet-bulb temperature was too low	May have to increase tower size. Discuss remedy with Marley representative.
	Actual process load greater than design	May have to increase tower size. Discuss remedy with Marley representative.
	Overpumping	Reduce water flow over tower to design conditions.
	Tower starved for air	Check motor current and voltage to be sure of correct contract power. Repitch fan blades if necessary. Clean louvers, fill and eliminators. Check to see if nearby structure or enclosing walls are obstructing normal airflow to tower. Discuss remedy with Marley representative.
Excessive drift exiting tower	Distribution basins overflowing	Reduce water flow rate over tower to design conditions. Be sure hot water basin nozzles are in place and not plugged.
	Faulty drift elimination	Check to see that integral fill, louvers and eliminators are clean, free of debris and installed correctly. If drift eliminators are separate from fill, make sure they are correctly installed in place. Clear if necessary. Replace damaged or worn out components.

additional information

Increased load requirements: AV Series towers are designed such that cells of either equal or unequal capacity can be added in the future. This allows you to compensate for the load increases that normally occur with the replacement or addition of production equipment—and still retain continuity with respect to your cooling tower system.

Tower rebuilding: SPX Cooling Technologies routinely rebuilds and upgrades cooling towers of all materials and manufacture. If your tower ever reaches the limit of its service life, we recommend that you investigate the cost of rebuilding before you routinely order a new replacement tower.

Each AV tower includes a document package containing general orientation drawings, a Field Installation Manual, and tower component user manuals. **These documents contain important information relating to safe installation and operation of the cooling tower.** Field installation is always required for piping inlets and piping outlets. The fan guard on larger models and some optional accessories, such as valves, handrails, ladders and safety cages may also require field installation. If installation details are not covered in the Field Installation Manual a separate installation drawing for each purchased option is included in the document package. If you have purchased an option and can't find the appropriate installation drawing, contact your local Marley sales representative before proceeding.

For complete parts and service assistance, contact the Marley sales representative in your area. If you need help locating the office nearest you, please phone 913 664 7400 or check the internet at spxcooling.com.

AV cooling tower

USER MANUAL

SPX COOLING TECHNOLOGIES, INC.

7401 WEST 129 STREET
OVERLAND PARK, KS 66213 USA
913 664 7400 | spxcooling@spx.com
spxcooling.com

Z0479216_C | ISSUED 8/2017
COPYRIGHT © 2017 SPX CORPORATION

In the interest of technological progress, all products are subject to design
and/or material change without notice.

