

Aquatower[®] cooling tower

INSTALLATION - OPERATION - MAINTENANCE

Z0504653_E ISSUED 8/2018

READ AND UNDERSTAND THIS MANUAL PRIOR TO OPERATING OR SERVICING THIS PRODUCT.



contents

This Manual contains vital information for the proper installation and operation of your cooling tower. Carefully read the manual before installation or operation of the tower and follow all instructions. Save this manual for future reference.

Overview	3
Tower Installation.....	5
Piping to Tower.....	5
Mechanical Equipment Installation	6
Motor Electrical Connections.....	9
Starting and Operating Instructions	10
Freezing Weather Operation.....	13
Maintenance Instructions	15
Blowdown.....	16
Cooling Tower Inspection and Maintenance	17
Seasonal Shutdown Instructions	18
Troubleshooting.....	20
Wiring Diagrams.....	21

The following defined terms are used throughout this manual to bring attention to the presence of hazards of various risk levels, or to important information concerning the life of the product.

⚠ Warning

Indicates presence of a hazard which can cause severe personal injury, death or substantial property damage if ignored.

⚠ Caution

Indicates presence of a hazard which will or can cause personal injury or property damage if ignored.

Note

Indicates special instructions on installation, operation or maintenance which are important but not related to personal injury hazards.

overview

This User Manual as well as those offered separately on motors, fans, couplings, drive shafts, float valves, pumps, etc., are intended to assure that this cooling tower serves you properly for the maximum possible time. Since product warrantability may well depend upon your actions, please read this User Manual thoroughly prior to operation.

This User Manual provides information regarding general cooling tower installation and operation. Any deviation from, change or modification to, the User Manual, the original design conditions or the original intended use of the equipment may result in improper installation and/or operation of the cooling tower. Any such deviation, change or modification shall be the responsibility of the party or parties making such deviation, change or modification. SPX Cooling Technologies, Inc. expressly disclaims all liability for any such deviation, change or modification. The equipment shall be warranted in accordance with the applicable SPX Cooling Technologies Certification of Limited Warranty.

If you have questions about the operation and/or maintenance of this cooling tower, and you don't find the answers in this manual, please contact your Marley sales representative. When writing for information, or when ordering parts, please include the serial number shown on the cooling tower nameplate.

Receiving Inspection:

The motor and miscellaneous parts ship with the tower. Check motor nameplate to be sure that power supply and motor have the same characteristics. Inspect the entire shipment for any damage that may have occurred in transit.

installation

⚠ Warning

Tower Location

The cooling tower must be located at such distance and direction to avoid the possibility of contaminated tower discharge air being drawn into building fresh air intake ducts. The purchaser should obtain the services of a Licensed Professional Engineer or Registered Architect to certify that the location of the tower is in compliance with applicable air pollution, fire, and clean air codes.

Locate so prevailing wind will blow into the louvered face, and direct fan discharge away from building surfaces. Locate so there is free air flow to and from the tower. Allow clearance on all sides for maintenance.

Indoor Installation:

Use a duct from the tower air discharge to the outside. You may also want to install an inlet air duct. Do not allow the total pressure loss through ducts to exceed 0.10 inches H₂O. To minimize pressure losses:

- Use 20% oversize ducts.
- Avoid sharp turns or abrupt changes in size.
- Keep duct length to a minimum.
- Screened or louvered openings should have a net free area at least 20% greater than the tower discharge opening area.

Attach ducts to the tower using flexible connections, and support ducts independently from the tower. Provide access openings for servicing the mechanical equipment if air discharge ducts are installed. If the duct discharges into the prevailing wind, you may need to install a windbreak or an elbow to serve as a deflector. Ducts installed on towers with year-round usage should be water tight and insulated to prevent condensation.

installation

Tower Installation:

Install tower in a level position on a stable foundation. Anchor tower to the foundation through holes at base of tower, using four $\frac{3}{8}$ " diameter bolts (not supplied). Remove strapping and brackets from the louver face on models 494–496 and reinstall the bolts to the cold water basin. Install the overflow (fiberglass models only) as shown in Figure 1.

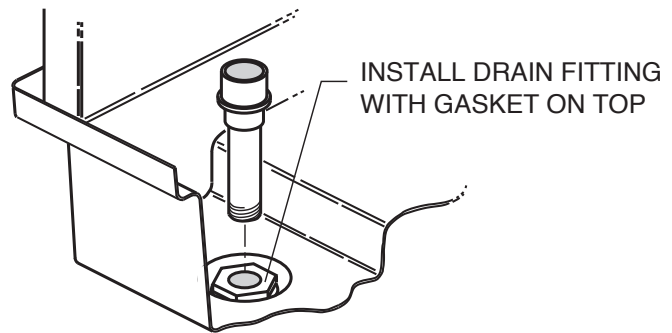

Figure 1

Piping to Tower: (Summer–Only Operation)

1. Use large enough piping to minimize friction loss.
2. Connect float valve to makeup water supply. Install the threaded valve stem and float located in the loose parts package.
3. Install a valved blowdown line at some point in the system, preferably in the hot water line near the top of the tower, so that water will flow through the line whenever the pump is operating. (Blowdown is the continuous removal of a small amount of water during operation to retard scale and corrosion.)

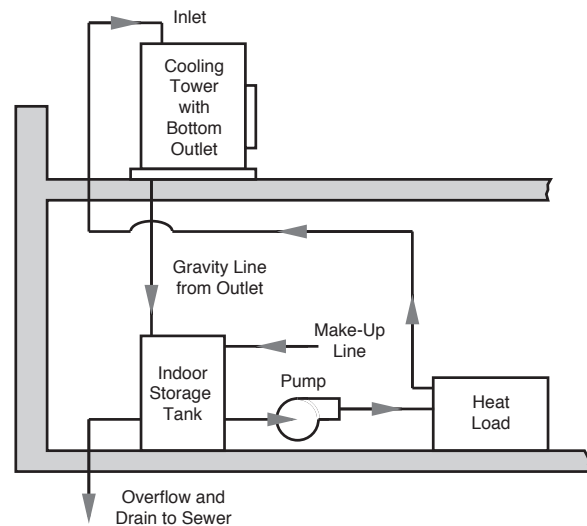

Figure 2

installation

Piping to Tower: (Year-Round Operation)

1. If your tower must operate during freezing weather, it is recommended that the tower be installed for gravity flow operation. See Figure 2.
2. Provide an indoor open type storage tank with a capacity that will contain all water that will drain into the tank from the system during shutdown.
3. Connect tower outlet to storage tank. Bottom outlet option should be used for gravity flow.
4. Install makeup water, bleed-off, overflow and drain lines on tank.
5. Insulate and heat water lines exposed to freezing temperatures.

Mechanical Equipment Installation

Note

Aquatowers with factory-installed controls ship with the motor, sheave, belt, and belt guard factory-installed. Remove shipping stiffener plate and hardware at the adjustable end of the motor support plate and proceed to Motor Electrical Connections.

Motor, Sheave, and V-Belt Installation:

1. Check the motor nameplate to be sure its voltage, phase and frequency ratings are the same as the power supply. ▶▶▶▶▶

Motor Frame Fastener Size

56-143T-145T	$\frac{5}{16}$ "
182T thru 215T	$\frac{3}{8}$ "

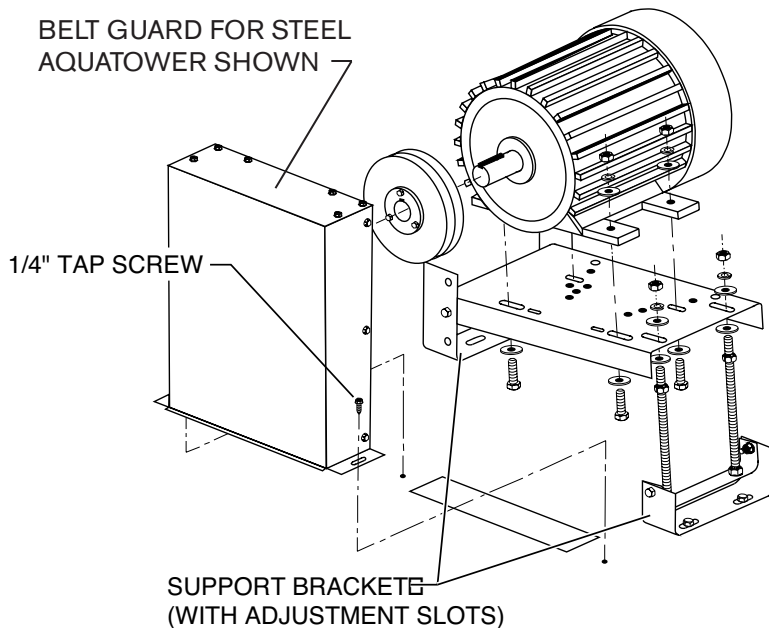

Figure 3

installation

2. Make sure the fan is tightly secured to the bearing housing shaft and that it rotates freely. Make sure the bearing housing is secured to its support.
3. Attach motor to motor base with four bolts, flat washers, lock washers and nuts provided, see Figure 3. You may want to loosen the adjusting bolts and raise the motor base so you can reach under the motor base to tighten the motor hold-down bolts.

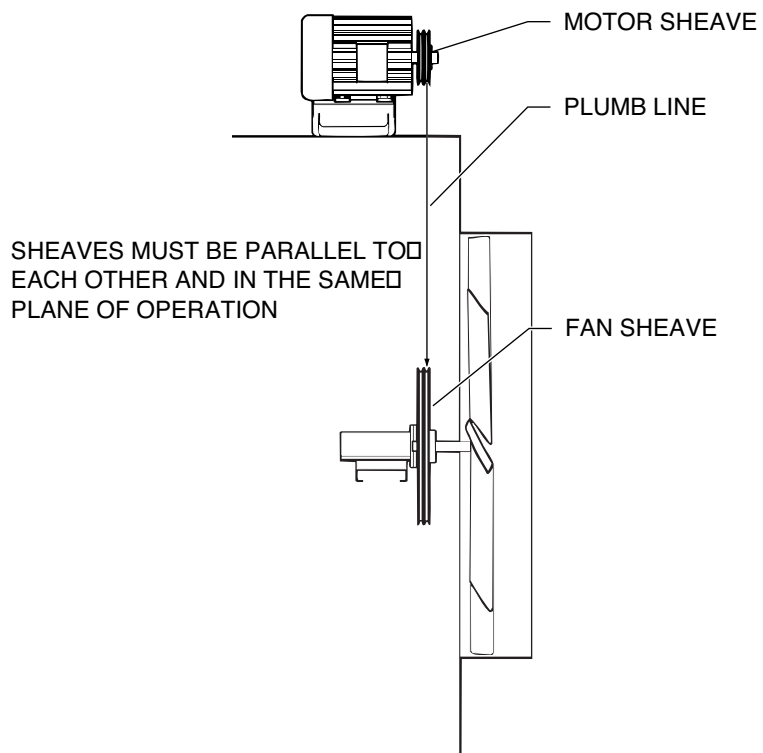

Figure 4

4. Apply a rust preventive coating to the motor shaft to prevent shaft corrosion and to ease sheave installation and removal.
5. Install motor sheave and align it with fan sheave. Motor support brackets are slotted to assist in alignment. See Figure 3. A plumb line will be helpful in aligning sheaves. See Figure 4.
6. Remove the fan guard and fan cylinder splice plate (steel tower only) at the top of the fan cylinder. Install the belt over the fan by passing the belt over the fan and rotating the fan blades past the belt. Install the belt onto the sheaves.



installation

7. Use the adjusting bolts on the motor support to adjust belt tension. A correctly tensioned belt does not slip when the fan is running—and the “tight” side is straight between sheaves. The “slack” side will have a slight bow. If possible, use a commercially available tension measuring device. **Avoid over-tensioning.** Too much tension reduces bearing and belt life. Check the tension on new belts after 8 to 12 hours of operation.
8. Install the belt guard as shown in Figure 3 for a steel tower or Figure 5 for a fiberglass tower.
9. Install fan cylinder splice plate (steel tower) and fan guard.
10. Check bearing housing oil cup level. Fill to the proper level with SAE 30 (ISO 100) weight oil.

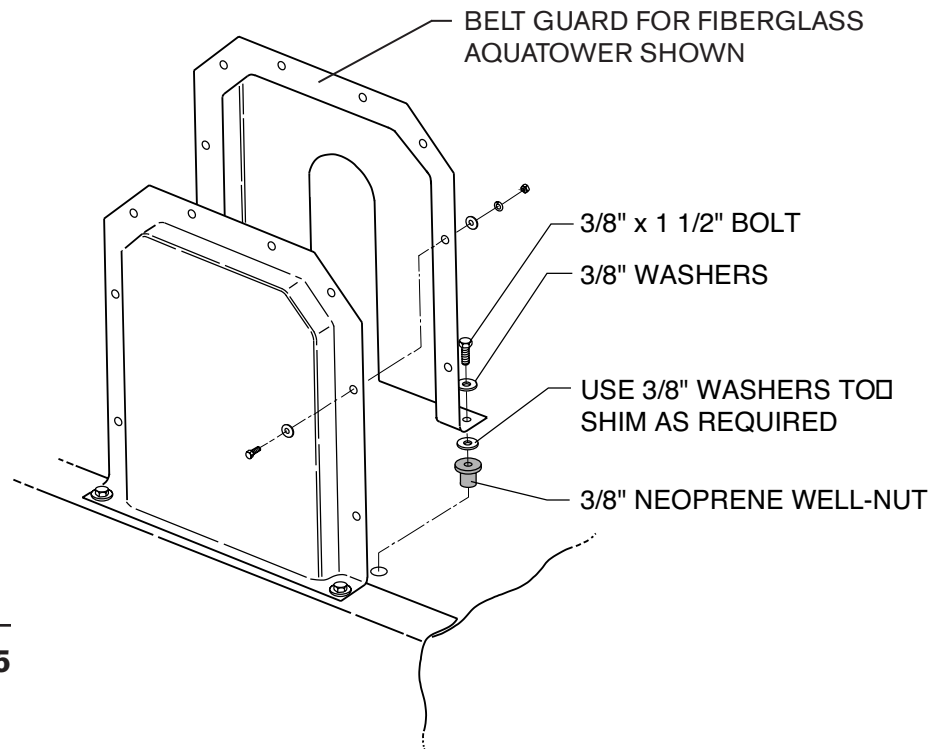

Figure 5

installation

Motor Electrical Connections

Note

If Aquatower is equipped with Marley Control System, refer to Control System Manual for wiring instructions.

Internal space heaters may be present, depending upon the motor manufacturer. For space heater operation and wiring refer to Marley “Fan Motor” User Manual Z0239042.

Connect motor to power supply in accordance with the National Electric Code and local requirements. Failure to wire the motor correctly will void its warranty. Overload protection for motors must be part of the control system. Figure 6 shows one possible control scheme. Other various wiring diagrams appear on pages 19 through 22.

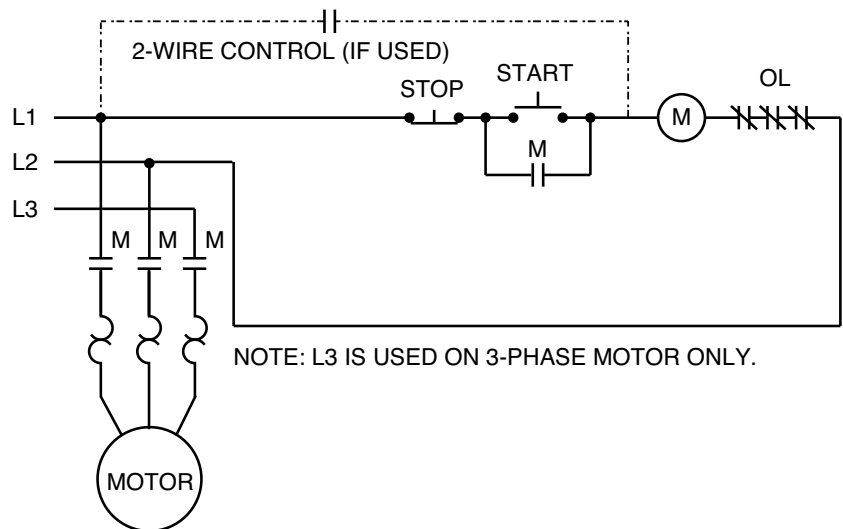

Figure 6

operation

Starting and Operating Instructions

⚠ Warning

Microorganisms including Legionella bacteria can exist in premise plumbing including cooling towers. The development of an effective water management plan (WMP) and implementation of maintenance procedures are essential to prevent the presence, dissemination and amplification of Legionella bacteria and other waterborne contaminants throughout premise plumbing. Before operating the cooling tower, the water management plan and maintenance procedures must be in place and regularly practiced.

1. Consult a knowledgeable water treatment professional to clean and treat your new cooling tower prior to startup. Cooling towers must be cleaned and disinfected regularly in accordance with ASHRAE Standard 188 and Guideline 12.
2. Do NOT attempt any service unless the fan motor is locked out.
3. Clean all debris, such as leaves and dirt from the cooling tower fill and basin.
4. Fill the circulating system with water. The cold water basin should be filled with water until level is at the rim of the overflow.

The water conditions during the initial tower operation are crucial in preventing premature corrosion of galvanized steel (white rust). For at least the first eight weeks of operation, pH should be controlled between 6.5 and 8.0 with hardness and alkalinity levels between 100 and 300 ppm (expressed as CaCO₃).

Note

If tower is equipped with a standard side-suction connection, vent any accumulated air from the top of the suction hood by removing one or both tap screws provided at that location. Replace these tap screws when venting is complete.

5. Start your pump(s). Observe system operation. Since the water system external to the tower will have been filled only to the level in the cold water basin, some “pump-down” of the basin water level will occur before water completes the circuit and begins to fall from the fill. The initial pump-down may not be enough to cause the float valve to open. However, you can check its operation by pressing down on the operating lever. Adjust the

operation

float valve during tower operation with heat load to maintain 4" water depth in the depressed section of the basin on Models 490–493. Maintain 5½" water depth on Models 494–496.

Note

Hot water temperatures exceeding 125°F could damage PVC fill.

6. Make sure blowdown line is discharging water.
7. Depth of water in hot water basin should be uniform. If the basin overflows, reduce the flow rate. Do not pump more water than design capacity.
8. Continue pump operation for about 15 minutes, after which it is recommended that the water system be drained, flushed, and refilled.
9. While operating the condensing water pump(s) and prior to operating the cooling tower fan, execute one of the two alternative biocidal treatment programs described in the following:
 - Resume treatment with the biocide which had been used prior to shut-down. Utilize the services of the water treatment supplier. Maintain the maximum recommended biocide residual (for the specific biocide) for a sufficient period of time (residual and time will vary with the biocide) to bring the system under good biological control
 - or**
 - Treat the system with sodium hypochlorite to a level of 4 to 5 mg/L (ppm) free chlorine residual at a pH of 7.0 to 7.6. The chlorine residual must be held at 4 to 5 mg/L (ppm) for six hours, measurable with standard commercial water test kits.

If the cooling tower has been in operation and then shut down for a duration of time and not drained, perform one of the two previous biocidal treatment programs directly to the cooling water storage vessel (cooling tower sump, drain down tank, etc.) without circulating stagnant water over the cooling tower fill or operating the cooling tower fan.

After biocidal pretreatment has been successfully completed, cooling water may be circulated over the tower fill with the fan off.

When biocidal treatment has been maintained at a satisfactory level for at least six hours, the fan may be turned on and the system returned to service. Resume the standard water treatment program, including biocidal treatment.



operation

10. Check fan for free rotation and check oil level in bearing housing as required (see maintenance instructions). Start motor and check direction of rotation. Fan must rotate clockwise when viewed from the fan discharge side. If the rotation is incorrect, change any two of the three motor leads.

Fan Cycling Limits:

Note

Considering the normal fan and motor sizes utilized on Aquatowers, anticipate that approximately 4 to 5 starts per hour are allowable.

If your tower is equipped with a two-speed motor, you will enjoy greater opportunity for temperature control. When the water temperature becomes too cold, switching the fan to half-speed will cause the cold water temperature to rise—stabilizing at a temperature a few degrees higher than before. With a further reduction in water temperature, the fan may be cycled alternately from half-speed to off.

Note

Do not start the motor more than four to five times per hour (each low speed start and each high speed start count as one start).

For greater insight on cold water temperature control, please read **“Cooling Tower Energy and its Management”**, Technical Report H-001, available on our website.

operation

Freezing Weather Operation

The Marley fill system used in the Aquatower has air entrance louvers that are molded as an integral part of the fill. This feature makes these towers very forgiving of cold weather operation, even at the low temperature and reduced load conditions encountered in free cooling and other low temperature applications. Nevertheless, during operation in subfreezing weather the opportunity exists for ice to form in the colder regions of the tower.

Note

Slushy, transitory ice forms routinely in the colder regions of the fill of low temperature towers, and is visible through the tower louvers. Such ice normally has no adverse effect on tower operation, but its appearance should be a signal to the operator to undertake ice control procedures.

It is the operator's responsibility to prevent the formation of destructive (hard) ice on the cooling tower fill. Certain guidelines should be followed:

1. Do not allow the tower's leaving water temperature to drop below a minimum allowable level—say 36°F to 40°F. If such low temperature operation is necessary or beneficial to your process, establish the minimum allowable level as follows:

During the coldest days of the first winter of operation, observe whether any ice is forming on the louver face, particularly near the bottom part of the louver face. If hard ice is present on the louvers, you must increase the allowable cold water temperature. If the coldest possible water is beneficial to your process, ice of a mushy consistency can be tolerated—but routine periodic observation is advisable.

⚠ Caution

If the minimum allowable cold water temperature is established at or near minimum heat load, it should be safe for all operating conditions.

2. As cold air enters the louvers, it causes the water flowing over the fill to be drawn inward toward the center of the tower. Thus, under fan operation, the louvers and lower periphery of the tower structure remain partly dry, seeing only random splashing from within the tower—plus normal atmospheric moisture from the entering air. Such lightly wetted areas are most subject to freezing.



operation

Therefore, if excessive ice forms on the louvers, stop the fan for a few minutes. With the fan off, the water flow will increase in the vicinity of the louvers and reduce the ice buildup.

3. Under extended extreme cold conditions, it may be necessary to operate the fan in reverse. This forces warm air out through the louvers, melting any accumulated ice—adequate heat load must be available. Reversal of fan should only be done at **half speed** or less. Reverse operation of the fan should be used sparingly and should only be used to control ice, **not** to prevent it. Reverse fan operation should not need to exceed 1 or 2 minutes. Monitoring is required to determine the time required to melt accumulated ice.

Warning

Operating the fan in reverse at half speed for prolonged periods during subfreezing weather can cause severe damage to fans and fan cylinders. Ice can accumulate inside fan cylinders at fan blade plane of rotation and fan blade tips will eventually strike this ring of ice, damaging the fan blades or cylinder. Ice can also accumulate on fan blades and be thrown off, damaging fan cylinder or blades. Allow a minimum of 10 minute delay between reverse operation and forward operation during subfreezing weather to permit ice to dissipate from fan blades and fan cylinders. See Fan cycling limits on page 11 of this manual.

4. With no heat load on the circulating water, icing cannot be controlled effectively by air control during freezing weather. **Towers must not be operated with reduced water rate and/or no heat load during freezing weather.** If the circulating water system cannot be shut down, water returning from the process should be made to bypass the tower. If a bypass is used, **all** water must be bypassed without modulation.

maintenance

Warning

Maintenance Instructions

Always make certain that mechanical equipment is inoperable during periods of maintenance or during any situation of possible endangerment to personnel. If your electrical system contains a disconnect switch, lock it out until the period of exposure to injury is over.

The top of the tower is not a working surface. Do not stand, sit or walk on top of the tower. Use an appropriate ladder adjacent to the tower whenever you perform any maintenance activity on the tower's upper surfaces.

This product is constructed of fiberglass or cold-formed sheet metal. Use protective clothing, gloves and shoes as appropriate for protection against edges of thin gage material.

Fan Motor:

Lubricate the motor according to the motor manufacturer's supplied instructions. Sealed bearing motors do not require lubrication maintenance. Refer to motor nameplate to determine if grease type and amount are specified. Remove any oil, dust or scale deposits from the motor which can cause excessive insulation temperatures.

Refer to Marley "**Fan Motor**" User Manual Z0239042 for additional maintenance and lubrication information.

Fan Shaft Bearing Housing:

Check bearing housing oil cup level. Fill to the proper level with SAE 30 (ISO 100) weight oil.

Belt Tension:

Check belt tension every two to three weeks during peak operating season.

Makeup Float Valve:

Check float valve periodically for proper operation and proper water level.

Basin and Suction Screen:

Drain and clean cold water basin and suction screen periodically.

Blowdown:

Check the blowdown for continuous water discharge during operation.



maintenance

Blowdown

A cooling tower cools water by continuously causing a portion of it to evaporate. Although the water lost by evaporation is replenished by the makeup system, it exits the tower as pure water – leaving behind its burden of dissolved solids to concentrate in the remaining water. Given no means of control, this increasing concentration of contaminants can reach a very high level.

In order to achieve water quality which is acceptable to the cooling tower (as well as the remainder of your circulating water system), the selected water treatment company must work from a relatively constant level of concentrations. This stabilization of contaminant concentrations is usually accomplished by blowdown, which is the constant discharge of a portion of the circulating water to waste. As a rule, acceptable levels on which to base a treatment schedule are in the range of 2–4 concentrations. The following table gives approximate blowdown rates (percent of total water flow rate constantly wasted) to achieve those concentrations at various cooling ranges*:

Blowdown Rate		
Cooling Range (°F)	Two Concentrations	Four Concentrations
6	0.7%	0.17%
8	1.1%	0.30%
11	1.5%	0.43%

*Range is the difference between hot water temperature entering the tower and cold water temperature leaving the tower.

Note

When water treatment chemicals are added, they should not be introduced into the circulating water system via the cold water basin of the cooling tower. Water velocities are lowest at that point, which results in inadequate mixing and may damage the cooling tower.

maintenance

Warning

Cooling Tower Inspection and Maintenance

Microorganisms including Legionella bacteria can exist in premise plumbing including cooling towers. The development of an effective water management plan (WMP) and implementation of maintenance procedures are essential to prevent the presence, dissemination and amplification of Legionella bacteria and other waterborne contaminants throughout premise plumbing. Before operating the cooling tower, the water management plan and maintenance procedures must be in place and regularly practiced.

In addition, the following steps are recommended:

Do NOT attempt any service unless the fan motor is locked out.

- Consult a knowledgeable water treatment professional to clean and treat your new cooling tower prior to startup. See Tower Startup section of this manual.
- Cooling towers must be cleaned and disinfected regularly in accordance with ASHRAE Standard 188 and Guideline 12.
- Workers performing decontamination procedures must wear personal protective equipment (PPE) as directed by their facility safety officer.
- Cooling towers must be visually inspected regularly to assess signs of bacterial growth, appearance of debris and scale on drift eliminators and general operating conditions. Refer to ASHRAE Standard 188 and Guideline 12 for specific frequency recommendations.
- Replace worn or damaged components.

To minimize the presence of waterborne microorganisms, including Legionella, follow the water management plan for your facility, perform regularly scheduled cooling tower inspections and maintenance, and enlist the services of water treatment professionals.

For additional technical support, contact your Marley sales representative. For help identifying the sales representative in your area, visit spxcooling.com/relocator.

References:

ashrae.org. Search “ASHRAE Standard 188” and “ASHRAE Guideline 12.”
cdc.gov. Search “Water Management Program.”

maintenance

Intermittent Freezing Weather Operation:

If periods of shutdown (nights, weekends, etc.) occur during freezing weather, measures must be taken to prevent the water in the cold water basin—and all exposed pipework—from freezing. Several methods are used to combat this, including automatic basin heater systems available from Marley.

⚠ Caution

Unless some means of freeze prevention is incorporated into your system, the tower basin and exposed pipework should be drained at the beginning of each wintertime shutdown period.

⚠ Warning

If tower basin is drained, verify that all basin heaters have been shut off either by automatic cutoff or disconnect switch.

Seasonal Shutdown Instructions

When the system is to be shut down for an extended period of time, it is recommended that the entire system (cooling tower, system piping, heat exchangers, etc.) be drained. Leave the basin drain open.

During shutdown, follow recommendations in the **Cooling Tower Inspection and Maintenance** section of this manual before attempting repairs. Apply protective coating as required to all metal parts. Pay particular attention to bearing housing supports.

Fan Shaft Bearing Housing:

- At shutdown, check the oil level in the oil cup.
- At start of new operating season, operate until the oil is warm—drain and refill. Use SAE 30 (ISO 100) weight oil.
- Bearing housing must be refilled at the point where the oil line from the oil reservoir cup connects to the bearing housing. Attach oil line and fill line and oil cup. Fan guard will have to be removed to change oil. Each month check the oil level at the oil cup.

maintenance

Fan Motor:

Clean and lubricate motor (if required) at close of each operating season. Refer to motor manufacturer's recommendations.

⚠ Warning

Do not start motor before determining that there will be no interference with free rotation of the fan drive.

The motor should be run for three hours at least once a month to dry out windings and lubricate bearing surfaces. Refer to Marley **"Fan Motor"** User Manual Z0239042.

At start of new operating season, make sure bearings are adequately lubricated before returning motor to service. Does not apply to motors with sealed bearings.

Prolonged Shutdown:

If shutdown period is longer than seasonal, contact your Marley Sales Representative for additional information.

Note

Whenever you order parts, or correspond with us about your tower, please include the tower serial number, located on the tower's name plate.

troubleshooting

Trouble	Cause	Remedy
Unusual motor noise	Motor running single-phase	Stop motor and attempt to start it. Motor will not start if single-phased. Check wiring, controls and motor.
	Motor leads connected incorrectly	Check motor connections against wiring diagram on motor.
	Bad bearings	Check lubrication. Replace bad bearings.
	Electrical unbalance	Check voltage and currents of all three lines. Correct if required.
	Rotor unbalance	Rebalance.
Motor runs hot	Motor overload, wrong voltage or unbalanced voltage	Check voltage and current of all three lines against nameplate values. Check nameplate RPM of motor and sheave ratio against parts list.
	Wrong fan RPM	Check nameplate RPM of motor and sheave ratio against parts list. Measure RPM.
	Bearings overgreased	Remove grease reliefs. Run motor up to speed to purge excessive grease. Does not apply to motors with sealed bearings.
	Wrong lubricant in bearings	Change to proper lubricant. See motor manufacturer's instructions.
	One phase open	Stop motor and attempt to start it. Motor will not start if single-phased. Check wiring, controls and motor.
	Poor ventilation	Clean motor and check ventilation openings. Allow ample ventilation around motor.
	Winding fault	Check with Ohmmeter.
	Bent motor shaft	Straighten or replace shaft.
	Insufficient grease	Remove plugs and regrease bearings. Does not apply to motors with sealed bearings.
	Too frequent starting	Limit cumulative starting time to a total of 30 seconds each hour.
	Deterioration of or foreign material in grease	Flush bearings and relubricate.
	Unusual fan drive vibration	Fan shaft bearings damaged
Loose bolts and cap screws		Tighten all bolts and cap screws on all mechanical equipment and supports.
Worn fan shaft bearings		Replace bearings.
Bent shaft		Replace shaft.
Misalignment		Make sure fan and motor are straight and properly aligned.
Loose or stretched belt		Check belt for proper tension.
Unbalanced motor		Disconnect load. Remove sheave, tape key in keyway and operate motor. If motor still vibrates, rebalance motor.

wiring diagrams

Capacitor Start Single Phase Motors, Reversible, Double Voltage

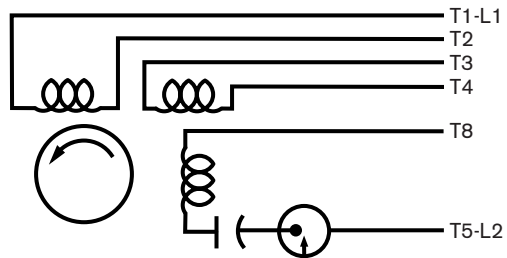

Without Thermal Overload (Integral HP)

High Voltage

1. Connect T1 and L1 and insulate.
2. Connect T2, T3 and T8 and insulate.
3. Connect T4, T5 and L2 and insulate.

Low Voltage

1. Connect T2, T3, T8 and L1 and insulate.
2. Connect T2, T4, T5 and L2 and insulate.

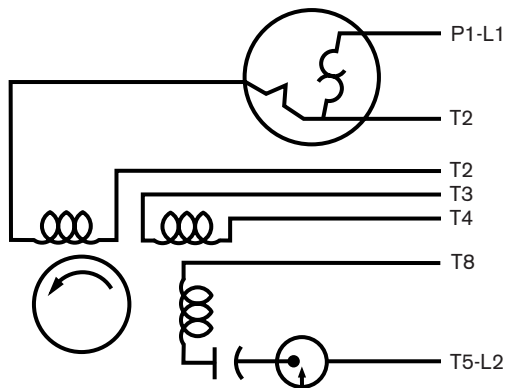

With Thermal Overload (Fractional HP)

High Voltage

1. Insulate P2.
2. Connect T2, T3 and L8 and insulate.
3. Connect T4, T5 and L2 and insulate.
4. Connect P1 and L1 and insulate.



wiring diagrams

Low Voltage

1. Connect P1 and L1 and insulate.
2. Connect P2, T3, and T8 and insulate.
3. Connect T2, T4, T5 and L2 and insulate.

General

Colors may be substituted for numbers as follows:

T1–Blue	T5–Black
T2–White	T6–Red
T3–Orange	P1–No Color Assigned
T4–Yellow	P2–Brown

To reverse rotation, interchange leads T5 and T8.

Three Phase Motors

There are two basic ways of wiring a three phase motor, Wye and Delta. The following show the terminal connections that could be used in Marley motors. Numbers could be stamped on insulation or cloth, plastic or metal bands around each lead.

1. Three Wire Single Voltage Motors–Leads are not always numbered. They could be numbered 1,2,3 or T1, T2 and T3.

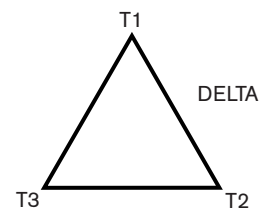
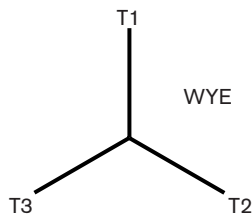

2. Nine Wire Dual Voltage Motors–Leads are numbered 1, 2, 3, 4, 5, 6, 7, 8 and 9 or T1, T2, T3, T4, T5, T6, T7, T8 and T9.

wiring diagrams

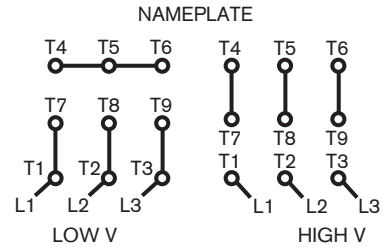
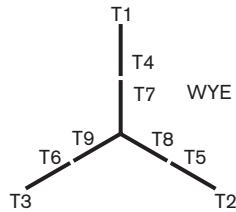

Voltage	L1	L2	L3	Tie Together
Low	T1 T7	T2 T8	T3 T9	T4 T5 T6
High	T1	T2	T3	(T4 T7) (T5 T8) (T6 T9)

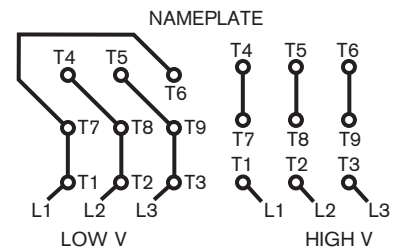
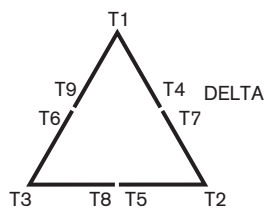

Voltage	L1	L2	L3	Tie Together
Low	(T1 T7 T6)	(T2 T8 T4)	(T3 T5 T9)	
High	T1	T2	T3	(T4 T7) (T5 T8) (T6 T9)

3. Two Speed Single Winding (Consequent Pole) Variable Torque Motor—
Leads are marked 1, 2, 3, 4, 5 and 6 or T1, T2, T3, T4, T5 or T6.

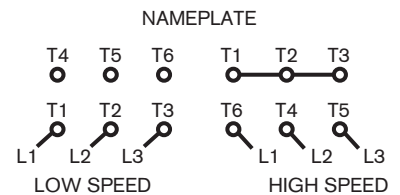
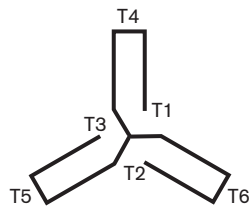

Speed	L1	L2	L3	Tie Together	Insulate Separately
Low	T1	T2	T3		T4-T5-T6
High	T6	T4	T5	T1 T2 T3	

Aquatower cooling tower

USER MANUAL

SPX COOLING TECHNOLOGIES, INC.

7401 WEST 129 STREET
OVERLAND PARK, KS 66213 USA
913 664 7400 | spxcooling@spx.com
spxcooling.com

Z0504653_E | ISSUED 8/2018

© 2010-2018 SPX COOLING TECHNOLOGIES, INC. | ALL RIGHTS RESERVED

In the interest of technological progress, all products are subject to design
and/or material change without notice.

