

Fluid Cooler Pump control panel

INSTALLATION - OPERATION - MAINTENANCE

Z0628618_C ISSUED 7/2020

READ AND UNDERSTAND THIS MANUAL PRIOR TO OPERATING OR SERVICING THIS PRODUCT.



introduction



NEMA 4X fiberglass outdoor enclosure with the following features:

- *Hinged and lockable outer door*
- *Swing-out dead front inner door*
- *Corrosion resistant enclosure*

Electrical Components

- *External disconnect handle with padlocking provisions to meet lockout, tag-out safety requirements*
- *Main circuit breaker with thermal and magnetic overload protection*
- *Door mounted operators* • *Pump starter*
- *Pilot lights* • *Status contacts*
- *Wiring diagram laminated and mounted on inside door*
- *Built to UL508 and CUL508 safety requirements*

Options:

- *Single Point Power Connection*
- *Integrated basin heater controls*
- *Integrated water level controls*
- *VFD feeder breaker if fan is controlled with remote VFD*
- *Factory installed and wired on selected products*

introduction

These instructions are intended to assure that field connections are completed properly and the control system operates for the maximum time possible. Since product warranty may depend on your actions, please read these instructions thoroughly prior to operation. Reference job specific wiring diagrams on the inside of the CoolBoost pump control panel.

If you have questions about the operation and/or maintenance of this control system and you do not find the answers in this manual, please contact your Marley sales representative.

Warning

Hazard of electrical shock or burn. Be sure to turn off power to the panel before servicing. If working on equipment out of site of panel disconnect, lockout using standard lockout procedure.

Safety First

The Marley control system uses UL listed components installed in accordance with the National Electric Code. The location of the cooling product and field installation of the control system can affect the safety of those responsible for installing, operating or maintaining the tower and controls. However, since SPX Cooling Technologies does not control the tower location, or field installation, we cannot be responsible for addressing safety issues that are affected by these items.

Warning

The following safety issues should be addressed by those responsible for installation, maintenance or repair of the tower and controls:

- ***Access to and from the control panel (including the customer supplied main disconnect/branch circuit protection.)***
- ***Proper grounding of electrical control circuits.***
- ***Sizing and protection of branch circuits feeding the control panel.***
- ***Qualification of persons who will install, maintain and service the electrical equipment.***

These are only some of the safety issues that may arise in the design and installation process. SPX Cooling Technologies strongly recommends that you consult a safety engineer to be sure that all safety considerations have been addressed.

Warning

Other safety issues are addressed in literature supplied with your cooling product. You should closely review the literature prior to installing, maintaining or repairing your cooling product.

installation

Circulating Pump Circuits

For the low-water safety circuit connect the two “low water probes”, located in the basin stilling chamber to user terminal points in the control panel. Marley probes are furnished with 20'-0" leads. Refer to the wiring diagram in the control panel for connection points.

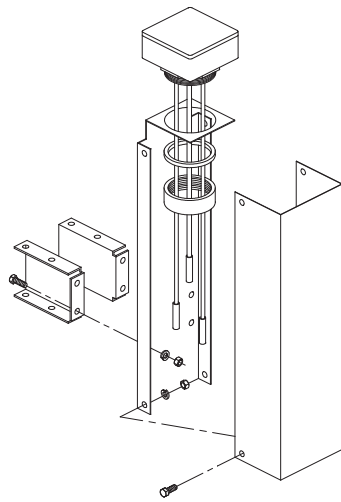

Stilling Chamber



Water Level Probes

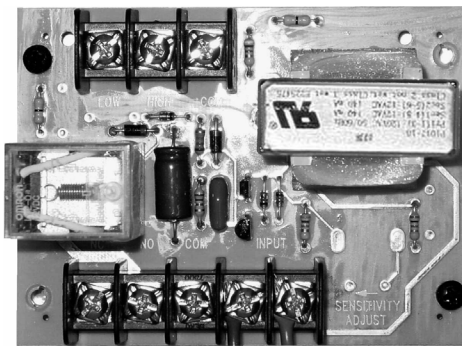

Water Level Card

installation

For the freeze safety circuit run two 18 gauge control wires from the thermostat located on the fluid cooler side casing to user terminal points in the control panel. The thermostat has two sets of terminal points. Use either the left or right two points oriented in a vertical column. Adjust the temperature range so the red arrow on the left points to 35°F as shown below.

Note

The thermostat, provided with this system, requires adjustment. Remove the inner most brass fitting located on the thermostat enclosure to gain access to the adjusting screw. Adjust cut-out set point temperature to 45°F. This automatically sets the cut-in point at 35°F.

Operation

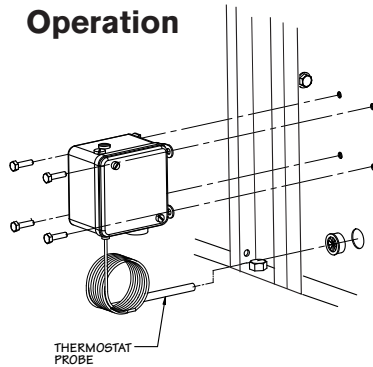

Thermostat Installed on Casing



Thermostat and Probe

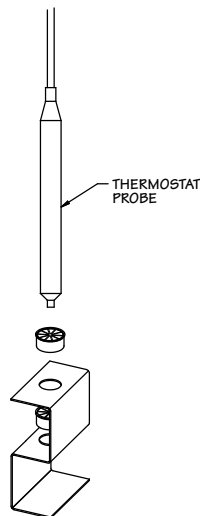

Thermostat Probe Installation

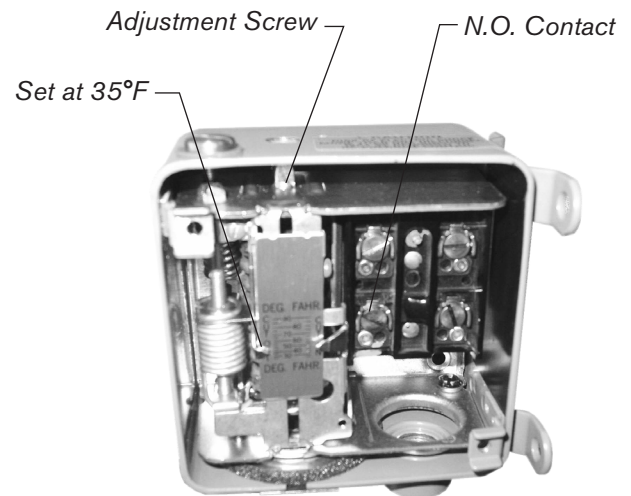

Thermostat

operation

Main Circuit Breaker: Operating handle for the main breaker is located behind the outer door which is pad-lockable for lock out/tag out.

Rotating the handle to the OFF position turns power off to the panel.

Rotating the handle to the ON position provides power to the control panel.

If servicing the panel hot (door open and main breaker in energized position) be sure to align the keyed slot on back of the operating handle with the key on the main breaker shaft before closing the door.

Power ON Light: A pilot light indicates the main disconnect is on and the control panel is powered.

Pump Operation

Standard operation of the pump is by manual control only, using a two-position selector switch located on the door. A removable “run enable” jumper is provided so customer may take control of cycling the pump. See the control panel wiring diagram.

Caution

Cycling the pump on and off for temperature control could cause scaling on the coils and is not recommended.

OFF-ON Selector Switch

- OFF position – pump motor is off.
- ON position – pump motor will run constantly unless a safety circuit is activated.

If the water temperature in the cold-water basin drops to 35°F a N.O. contact from the remote thermostat will close and latch-in a relay, which in turn shuts off the circulating pump. This is a safety circuit to prevent pumping freezing water. To reset this circuit, press the reset button on the door. The circuit can be only reset once the cold-water basin temperature rises above 45°F.

If the basin water drops to a dangerously low level, the water level card contact will close and also energize the latch-in relay shutting the circulating pump off. This is a safety circuit preventing the pump from running dry. To reset this circuit, press the reset button on the door. The circuit can only be reset if the water in the basin has risen to an acceptable operating level.

operation

Integrated Basin Heater Control Circuit Option

The Marley ABHi basin heater package controls the ON and OFF operation of the basin heater device providing freeze protection in the cold-water collection basin of the fluid cooler. The stand-alone control package includes a main circuit breaker disconnect that feeds a contactor providing power for the heater element.

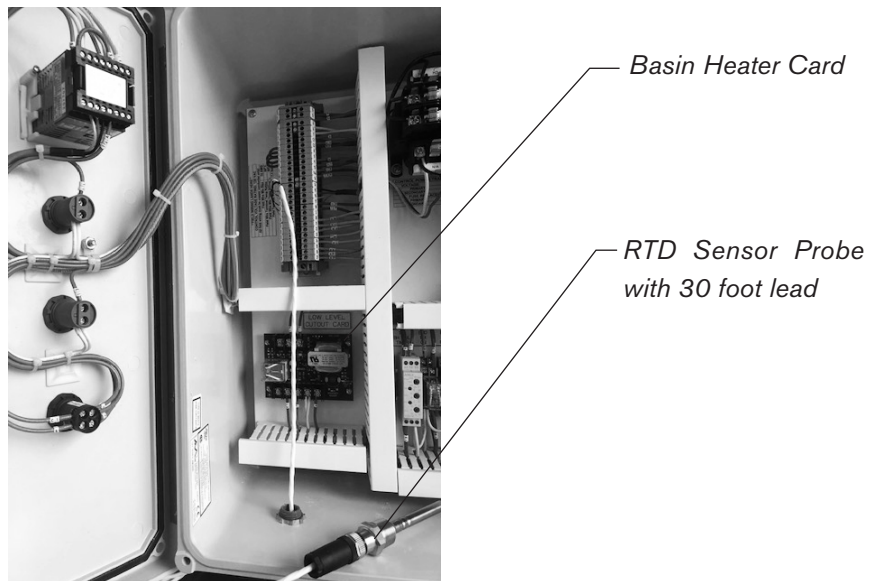

An RTD (resistant temperature device) monitors water temperature in the basin for the temperature controller and includes a low water cutout circuit preventing the control from energizing if the sensor is not submerged in water. Standard sensor lead length is 30'-0"; longer leads are available.

The solid-state control card is located inside the control panel. A power contactor inside the control panel is used to energize the heating element.

The temperature card and basin heater element maintain water temperature in the basin between 40°F and 45°F.

Refer to Marley "ABHi Basin Heater Integrated Controller" User Manual Z1079659 for additional information.

operation

Solid-state Water Level Control and Alarm Circuit Option

The number of probes depends on the number of optional circuits being furnished. Each water level event requires one card. The card includes an on-board relay with (1) form "C" dry contact. Contacts are wired to a user terminal strip for connection to remote devices such as make-up solenoids and alarms.

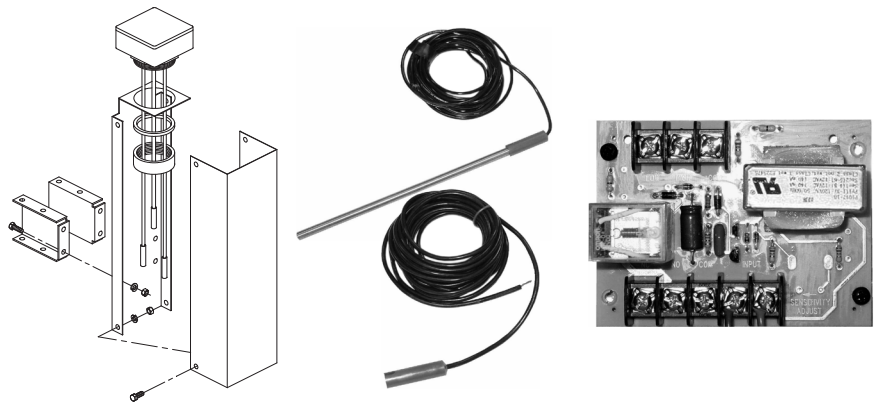

Stilling Chamber

Water Level Probes

Water Level Card

Water make-up control – Form "C" 1- N.O. 1 – N.C. contact wired to 120 VAC fused circuit for customer use to power a remote solenoid.

High water alarm - N.O. contact wired to user terminal block

Low water alarm - N.O. contact wired to user terminal block

High water cutoff – N.C. contact wired to user terminal block

Low water cutoff - N.C. contact wired to user terminal block

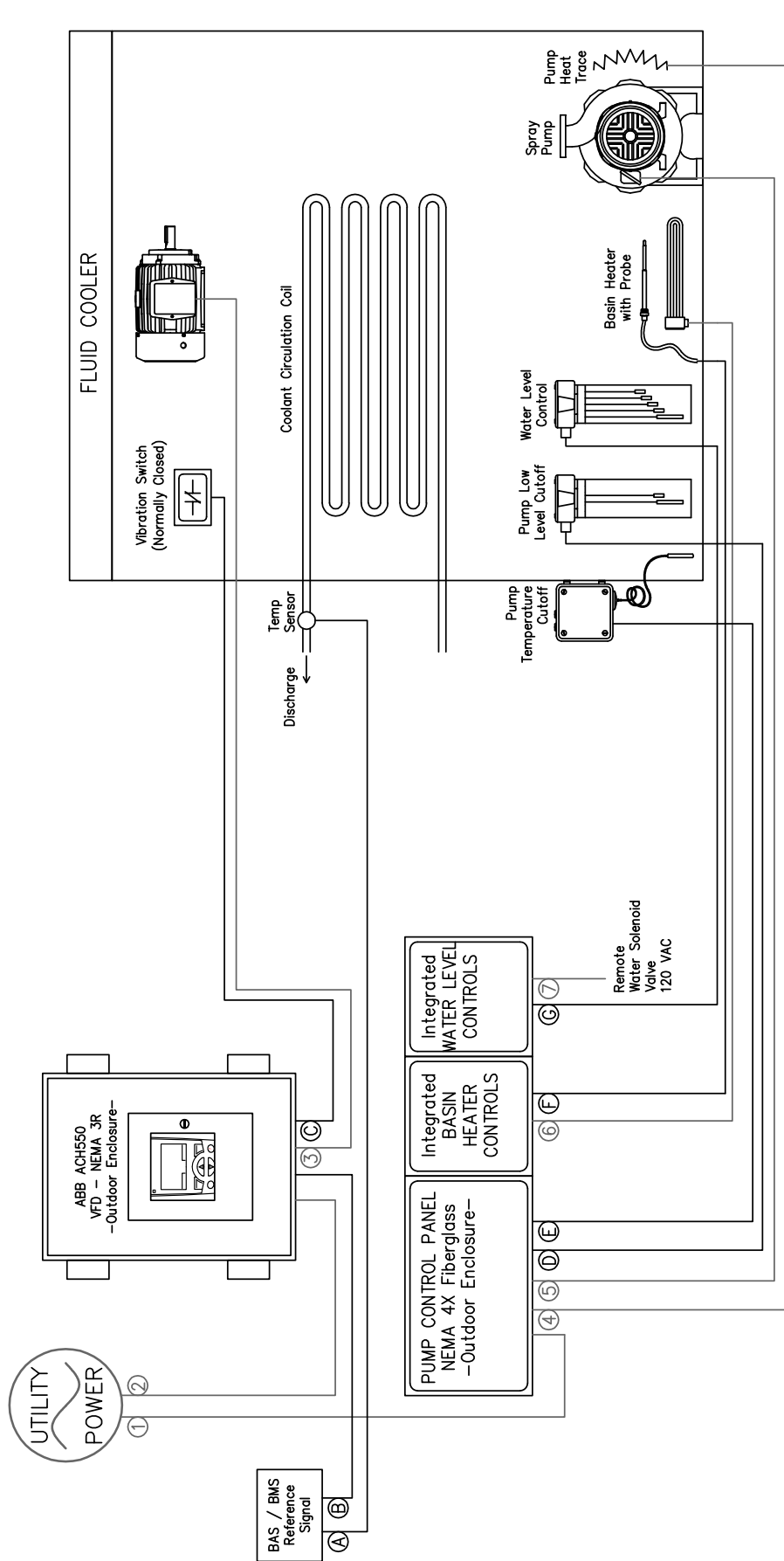

- ① - Feed from utility power to pump/combo control by others, (3) wires plus ground (NEC)
- ② - Feed from utility power to VFD by others, (3) wires plus ground (NEC)
- ③ - Feed from VFD to motor by others, (3) wires plus ground (NEC)
- ④ - Feed from pump/combo control to heat trace by others, (2) wires plus ground (NEC)
- ⑤ - Feed from pump/combo control to pump motor by others, (3) wires plus ground (NEC)
- ⑥ - Feed from pump/combo control to basin heater by others, (3) wires plus ground (NEC)
- ⑦ - Feed from water level control to solenoid by others, (2) wires plus ground (NEC)

- Ⓐ - From temperature sensor to Building Management System
- Ⓑ - 4-20ma speed reference signal from BMS to VFD
- Ⓒ - Vibration N.C. contacts to VFD
- Ⓓ - Pump/combo to low level cutoff probes, (2-20ft) 18 AWG furnished by Marley
- Ⓔ - Pump circuit to thermostat, (2) 18 AWG wires by others (freeze protection)
- Ⓕ - Basin heater probe cable (4 wires w/shield) furnished by Marley
- Ⓖ - Water level control system, (5) 18 AWG wires 20 foot each, furnished by Marley

— = POWER WIRING
 - - - = CONTROL WIRING

Fluid Cooler Pump control panel

USER MANUAL

SPX COOLING TECHNOLOGIES, INC.

7401 WEST 129 STREET
OVERLAND PARK, KS 66213 USA
913 664 7400 | spxcooling@spx.com
spxcooling.com

Z0628618_C | ISSUED 7/2020

©2009-2020 SPX COOLING TECHNOLOGIES, INC. ALL RIGHTS RESERVED

In the interest of technological progress, all products are subject to design
and/or material change without notice.

