

DTC evaporative condenser

INSTALLATION - OPERATION - MAINTENANCE

Z0921107_D ISSUED 6/2024

READ AND UNDERSTAND THIS MANUAL PRIOR TO OPERATING OR SERVICING THIS PRODUCT



contents

Note

This manual contains vital information for the proper installation and operation of your evaporative condenser. Carefully read the manual before installation or operation of the evaporative condenser and follow all instructions. Save this manual for future reference.

Overview	3
Location.....	4
Shipment.....	4
Receiving	5
Hoisting	5
Installation.....	6
Motor Wiring	8
Mechanical Equipment	10
Startup.....	12
Operation.....	14
Dry Operation	15
Freezing Weather Operation.....	15
Water Quality and Blowdown.....	17
Evaporative Condenser Inspection and Maintenance.....	18
Water Collection Basin Access/ Air Inlet Louver Removal	19
Access Door Operation.....	20
Belt Tensioning	21
Sheave Alignment.....	24
Fan Motor Access and Removal	25
Drift Eliminator Removal and Replacement	27
Distribution System Maintenance	28
Routine Maintenance	29
Seasonal Shutdown Instructions	32
Maintenance Schedule.....	37
Troubleshooting.....	38

The following defined terms are used throughout this manual to bring attention to the presence of hazards of various risk levels, or to important information concerning the life of the product. Also, please observe all Caution and Warning labels on the tower.

⚠ Warning

Indicates presence of a hazard which can cause severe personal injury, death or substantial property damage if ignored.

⚠ Caution

Indicates presence of a hazard which will or can cause personal injury or property damage if ignored.

Note

Indicates special instructions on installation, operation or maintenance which are important but not related to personal injury hazards.

overview

This User Manual as well as those offered separately on motors, fans, Geareducer, couplings, drive shafts, float valves, pumps, etc., is intended to assure that this evaporative condenser serves you properly for the maximum possible time. Since product warrantability may well depend upon your actions, please read this User Manual thoroughly prior to operation.

This User Manual provides information regarding general equipment installation and operation. Any deviation from, change or modification to, the User Manual, the original design conditions or the original in-tended use of the equipment may result in improper installation and/or operation.

Any such deviation, change or modification shall be the responsibility of the party or parties making such deviation, change or modification. SPX Cooling Technologies, Inc. expressly disclaims all liability for any such deviation, change or modification. The equipment shall be warranted in accordance with the applicable SPX Cooling Technologies Certification of Limited Warranty.

If you have questions about the operation and/or maintenance of this evaporative condenser, and you don't find the answers in this manual, please contact your sales representative. When writing for information, or when ordering parts, please include the serial number shown on the equipment nameplate.

Safety First

The location and orientation of the evaporative condenser can affect the safety of those responsible for installation, operation or maintenance. However, since SPX Cooling Technologies does not determine the evaporative condenser location or orientation, we cannot be responsible for addressing those safety issues that are affected by evaporative condenser location or orientation.

Warning

The following safety issues should be considered by those responsible for designing the evaporative condenser installation.

- ***Access to and from the collection basin***
- ***Access to and from mechanical access door(s)***
- ***The possible need for ladders (either portable or permanent) to gain access to the mechanical access doors(s)***
- ***The possible need for safety cages around ladders***
- ***The possible need for external mechanical access platforms***
- ***Access issues due to obstructions surrounding the evaporative condenser***
- ***Lockout of mechanical equipment***
- ***The need to avoid exposing maintenance personnel to the potentially unsafe environment inside the evaporative condenser.***



overview

Those are only some of the safety issues that may arise in the design process. SPX strongly recommends that you consult a safety engineer to be sure that all safety considerations have been addressed.

Several options are available that may assist you in addressing some of these personnel safety concerns, including:

- mechanical access platform and ladder
- ladder extensions (used where the base of the tower is elevated)
- safety cages for ladders
- safety gates for platforms

Location

Space available around the evaporative condenser should be as generous as possible to promote ease of maintenance—and to permit freedom of airflow into and through the evaporative condenser. If you have questions about the adequacy of the available space or the intended configuration of the equipment, please contact your SGS Refrigeration sales representative for guidance.

Prepare a stable, level support foundation for the evaporative condenser, utilizing weight, wind load, and dimensional information appearing on appropriate SGS Refrigeration submittal drawings. Supports must be level to insure proper operation of the evaporative condenser.

⚠ Warning

The evaporative condenser must be located at such distance and direction to avoid the possibility of contaminated discharge air being drawn into building fresh air intake ducts. The purchaser should obtain the services of a Licensed Professional Engineer or Registered Architect to certify that the location of the equipment is in compliance with applicable air pollution, fire and clean air codes.

Shipment

Unless otherwise specified, evaporative condensers ship by truck (on trailer(s)), which lets you receive, hoist, and install in one continuous operation. Smaller single-cell evaporative condensers generally ship on one truck. Larger single-cell evaporative condensers, multi-cell evaporative condensers, and evaporative condensers with access options (i.e. factory assembled platforms) may require more than one truck.

Responsibility for the condition of the evaporative condenser upon its arrival belongs to the trucker—as does the coordination of multiple shipments, if required.

receiving and hoisting

Receiving

Prior to unloading the evaporative condenser from the delivering carrier, inspect the shipment for evidence of damage in transit. If damage is apparent, note the freight bill accordingly. This will support your future recovery claim.

Find and remove the installation instruction drawings and bills of material located in a plastic tub in the crate accompanying the evaporative condenser. This information should be kept for future reference and maintenance purposes.

Hoisting

All DTC evaporative condenser models must use hoist clips and overhead lifting for handling assembled shipping modules. **Fork lifting from base of evaporative condenser modules is not permitted.** Hoisting clips are located at the bottom of the basin (bottom) module and at the bottom of the coil/fan (top) module. On models where the upper fan module is shipped separately from the coil module, hoisting clips are located at the fan deck level on the fan (top) module and at the bottom of the coil (middle) module. Never use hoisting clips located at the fan deck level if the fan and coil modules are combined. A **Hoisting-Installation** label which has hoisting dimensional information is located on the side casing of the equipment, and a hoisting drawing is located in the installation instruction drawings accompanying the equipment. Remove evaporative condenser from the trailer and hoist into place according to the instructions.

Warning

Modules must be hoisted and set according to instructions. Do not preassemble modules prior to hoisting unless specifically allowed in the hoisting drawing for that model size and configuration. Under no circumstances should you use hoisting clips located at the fan deck level if the fan and coil modules are combined.

Hoisting clips are provided for ease of unloading and positioning the evaporative condenser. For overhead lifts or where additional safety is required, safety slings should also be placed under the evaporative condenser modules.

installation

Note

Installation

These installation instructions are intended to help you prepare before your evaporative condenser arrives. If discrepancies exist between these instructions and those shipped with the evaporative condenser, the instructions shipped with the evaporative condenser will govern

1. Prior to placement of the evaporative condenser, confirm that the supporting platform is level, and that the anchor bolt holes are correctly located in accordance with SGS Refrigeration drawings. If your installation uses vibration isolators to dampen vibration, they must be mounted below the supporting steel. See support drawings for further information.
2. Place basin (bottom) module on your prepared supports, aligning anchor bolt holes with those in your supporting steel. Make sure that the orientation agrees with your intended piping arrangement. Attach to supporting steel with bolts and flat washers (by others) – see support drawing for size, location and quantity. Position flat washers between the bolt head and the evaporative condenser basin flange.
3. Before setting coil module (middle module on 3-piece shipments, top module on 2-piece shipments) in place on the basin module, clean any debris from the underside of the coil module and the top of the basin module. Apply sealing gasket tape to the top of the basin module per the installation instructions shipped with the evaporative condenser. Make sure that the orientation of the modules agrees with your intended piping arrangement. Pay close attention to face designations on sales orientation drawings e.g. Face A, Face B, etc. Place coil module on the top peripheral bearing surface of basin module, aligning mating holes with drift pins as it is set in place. Use care when setting the modules as lifting and resetting will compromise the sealing gasket between the two sections, possibly resulting in a leaking joint. If the modules must be reset, it may be necessary to remove the sealing gasket tape and replace. Attach the modules together with fasteners provided according to drawings shipped with your evaporative condenser.

Note

Sealing details must be followed correctly or leaks may occur that will not be covered under warranty.

installation

4. Connect the recirculation piping with rubber coupling shipped with the bottom module piping according to drawings shipped with the evaporative condenser.

Note

If evaporative condenser fan and coil sections are combined for shipment, skip step 5.

5. If the evaporative condenser was shipped with the fan and coil in separate modules, it is necessary to now set the fan module. Before setting fan module in place on the coil module, clean any debris from the underside of the fan module and the top of the coil module. Apply sealing gasket tape to the top of the basin module per the installation instructions shipped with the evaporative condenser. Pay close attention to module orientation and face designations on sales orientation drawings. Place coil module on the top peripheral bearing surface of basin module, aligning mating holes with drift pins as it is set in place. Use care when setting the modules as lifting and resetting will compromise the sealing gasket between the two sections, possibly resulting in a leaking joint. Attach the modules together with fasteners provided according to drawings shipped with your evaporative condenser.
6. Attach makeup water supply piping to appropriately-sized float valve connection located in collection water basin side wall. Install the drain and overflow according to drawings shipped with your evaporative condenser. If you wish to pipe overflow and drain water to a remote discharge point, make those connections at this time also.

Note

Fasteners and components provided by others that are to be attached to the evaporative condenser must be compatible with the evaporative condenser materials—i.e. fasteners in a stainless steel cold water basin must be stainless steel.

7. Attach the refrigerant supply and return piping to the condenser coil connections. Coils are charged with nitrogen to approximately 20 psig at the factory. Upon installation, coil connections require cutting and beveling. Protect adjacent areas from excessive heat and sparks or damage may occur. It is recommended that weld areas be protected against corrosion. Cold galvanizing is suggested for weld areas on galvanized coils, applied according to the manufacturer's instructions.



installation

⚠ Caution

Except for the horizontal components of piping, do not support your piping from the evaporative condenser inlet / outlet connections – support it externally.

Protect adjacent areas from excessive heat and sparks during welding or damage may occur.

8. Wire fan motor(s) and recirculation pump motor(s) in accordance with wiring diagrams.

⚠ Warning

For maintenance/safety purposes, SPX recommends a lockout type disconnect switch for all mechanical equipment. In addition to a disconnect switch, the motor(s) should be wired to main power supply through short circuit protection, and a magnetic starter(s) with overload protection.

Motor Wiring

Wire motor leads as shown on the motor nameplate matching the supply voltage. Do not deviate from the motor nameplate wiring.

Internal space heaters may be present, depending upon the motor manufacturer. For space heater operation and wiring refer to the SGS Refrigeration “Fan Motor” User Manual Z0239042.

Either of following symbols may be shown on the motor nameplate – Δ , $\Delta \Delta$, Y, or YY. These symbols represent how the motor is constructed on the inside and in no way have anything to do with a Delta or Wye electrical distribution system serving the motor.

When using a starter:

- Set motor overload protection to 110% of motor nameplate amps. This setting allows the fan motor to operate during cooler weather. During cooler weather it is common for the motor to draw 6 to 10% higher than nameplate amps. High amps are common during evaporative condenser commissioning when the evaporative condenser is dry and the ambient air temperature is cool.

Note

Do not start the motor more than four to five times per hour. Short cycling the motor(s) will cause fuses, breakers or O.L.s to operate and will decrease motor life.

installation

When using a two-speed starter:

- Motor rotation must be the same at slow speed and high speed.
- Single winding motor requires a starter with a shorting contactor.
- Two-winding motor requires a starter with out a shorting contactor.
- All two-speed starters must have a 20 second time delay relay when switching from high speed to low speed.

Note

Do not start the motor more than four to five times per hour (each low speed start and each high speed start count as one start).

When using a VFD:

Note

Before beginning, ensure that the motor is rated for “Inverter Duty” per NEMA MG-1, part 31.

- Set the VFD solid state overload protection to 119% of motor nameplate amps and set “maximum current parameter” in the VFD to motor nameplate amps. “Maximum current parameter” will reduce fan speed and limit amp draw to nameplate amps during cold weather operation. If furnished with a mechanical O.L. set this at 110% over motor nameplate amps.
- Motor rotation must be the same in both VFD mode and By-pass mode.
- If cable distance between the VFD and motor is greater than 100 feet a DV/DTC output filter is recommended to avoid damage to the motor. 100 feet distance is based on our field experience, the VFD manufacture may state different distances and distance does vary depending on the VFD manufacture.
- Program the VFD for variable torque output.
- Do not start and stop the motor using the safety switch at the motor. If the drive is being commanded to run and the load side is cycled ON and OFF with the safety switch this may damage the VFD.

Using a VFD in cooling applications has advantages over traditional single or two speed motor control. A VFD can reduce the cost of electrical energy being used and provide better temperature control. In addition, it reduces the mechanical and electrical stress on the motor and mechanical equipment. Electrical savings can be large during periods of low ambient temperature when the cooling requirement can be satisfied at reduced speeds. To benefit from these advantages, it is important that the drive be installed correctly.



installation

SGS Refrigeration supplies VFD and VFD controls specifically designed for our cooling products. If you have purchased a SGS Refrigeration VFD and/or controls package, please follow the instructions in the User Manual for that system. Most VFD problems can be avoided by purchasing the SGS Refrigeration drive system. If you are installing a VFD other than the SGS Refrigeration drive, please refer to that drives installation manual.

⚠ Warning

Improper use of a VFD may cause damage to equipment or personal injury. Failure to correctly install the VFD drive will automatically void all warranties associated with the motor and any equipment that is either electrically or mechanically (directly) attached to the VFD drive system. The length of this warranty avoidance will be contingent on properly installing the VFD system and repairing any damage that may have occurred during its operation. SPX Cooling Technologies does not assume responsibility for any technical support or damages for problems associate with non-SGS Refrigeration brand VFD systems.

Changing the operational fan speed from the factory settings could cause the fan to operate in an unstable region which may result in damage to the equipment and possible injury.

The evaporative condenser is designed to operate at full speed and half speed. Warranty is void if the evaporative condenser is operated at speeds which cause damaging vibrations to the evaporative condenser and associated equipment. When utilizing a variable frequency drive, the evaporative condenser must be tested across the full range of speeds and checked against CTI guidelines for excessive vibration. Speed ranges not meeting these guidelines must be locked out in the VFD.

Mechanical Equipment:

⚠ Warning

Always shut off electrical power to the evaporative condenser fan motor prior to performing any maintenance on the tower. Any electrical switches should be locked out and tagged out to prevent others from turning the power back on.

1. If equipped, check Geareducer oil level. Although the Geareducer was filled to the proper level at the factory, tipping during shipment and hoisting may have caused some loss of oil. If oil is required, fill Geareducer to the proper level with approved lubricant. See **Geareducer User Manual**.

installation

Check oil level at the Geareducer or dipstick (standpipe located on fan deck, if so equipped) to confirm that the proper level is indicated.

2. Spin the fan(s) manually to assure that all fan blades properly clear the inside of the fan cylinder. If equipped, observe the action of the coupling (or drive shaft couplings) to be sure that the motor and Geareducer are properly aligned. If necessary, correct the alignment in accordance with the included manual. For belt drive equipped models observe the action of the sheaves and belts to be sure that the motor is properly aligned with the fan sheave. See **Belt Tensioning** and **Sheave Alignment** on pages 21 and 24.

⚠ Warning

The following steps require operation of the fan motor while the access door is open. See Access Door Operation on page 20. DO NOT view the fan operation from near or inside the access door location. Fan rotation should be viewed from grade.

⚠ Caution

The access door should NOT be opened while the fan is operating. The fan rotation causes a negative pressure inside the evaporative condenser and will abruptly pull the door open should access be attempted. Only open the access door when the fan is off and locked out.

3. Momentarily bump (energize) the motor(s) and observe rotation of the fan(s). If rotation is backwards, shut off the fan and reverse two of the three primary leads supplying power to the motor.

⚠ Caution

If evaporative condenser is equipped with a two-speed motor, check for proper rotation at both speeds. Check also to see that starter is equipped with a 20 second time delay which prevents direct switching from high speed to low speed. If the fan is intended to be reversed for deicing purposes, make sure that the starter is equipped with a 2 minute time delay between changes of direction. These delays will prevent abnormal stress from being applied to the mechanical equipment and the electrical circuit components.

4. Run the motor and observe the operation of the mechanical equipment. Operation should be stable, and, if equipped, there should be no evidence of oil leakage from the Geareducer.
5. If equipped with belt drive, check belt tension and torque on the fan and motor sheave after 10 - 60 hours of operation. See **Bushing Fastener Torque Values** on page 25.



installation

Note

If the water supply system is not being operated—or if there is no heat load on the system—motor amps read at this time may indicate an apparent overload of as much as 10–20%. This is because of the increased density of unheated air flowing through the fan. Determination of an accurate motor load should await the application of the design heat load.

Startup

⚠ Warning

Microorganisms including Legionella bacteria can exist in premise plumbing including cooling towers. The development of an effective water management plan (WMP) and implementation of maintenance procedures are essential to prevent the presence, dissemination and amplification of Legionella bacteria and other waterborne contaminants throughout premise plumbing. Before operating the cooling tower, the water management plan and maintenance procedures must be in place and regularly practiced.

Water System:

1. Consult a knowledgeable water treatment professional to clean and treat your new cooling tower prior to startup. Cooling towers must be cleaned and disinfected regularly in accordance with ASHRAE Standard 188 and Guideline 12.

The water conditions during the initial tower operation are crucial in preventing premature corrosion of galvanized steel (white rust). For at least the first eight weeks of operation, pH should be controlled between 6.5 and 8.0 with hardness and alkalinity levels between 100 and 300 ppm (expressed as CaCO₃).

2. Do NOT attempt any service unless the fan motor is locked out.
3. Remove any and all accumulated debris from evaporative condenser. Pay particular attention to inside areas of collection water basin, distribution water system, louvers and drift eliminators. Make sure that recirculating water suction screens are clear and properly installed.
4. Fill the water system to the recommended operating water level. Shown on the outlet piping drawing accompanying the evaporative condenser, the recommended operating water level is typically a depth of 7" - 8" in the depressed area of the collection water basin. Adjust the float valve so that it is 75% open at that level. Continue filling the system until the water reaches a level approximately 1/8" below the lip of the overflow.

installation

5. Start your pump(s) and check for proper rotation as indicated by the arrow on the pump cover, observe system operation. A certain amount of “pump-down” of the basin water level will occur before water completes the circuit and begins to fall from the coil(s). The amount of initial pump-down may be insufficient to cause the float valve to open. However, you can check its operation by pressing down on the operating lever to which the stem of the float valve is attached.

Some trial and error adjustment of the float valve may be required to balance the makeup water with evaporative condenser operation. Ideally, the float valve setting will be such that no water is wasted through the overflow at pump shutdown. However, the water level after pump start-up must be deep enough to assure positive pump suction.

6. Open the valve on the evaporative condenser bleed line and adjust bleed to the recommended rate. See **Water Quality and Blowdown** section.
7. Continue pump operation for about 15 minutes, after which it is recommended that the water system be drained, flushed and refilled.
8. While operating the recirculating water pump(s) and prior to operating the evaporative condenser fan(s), execute one of the two alternative biocidal treatment programs described in the following:
 - Resume treatment with the biocide which had been used prior to shut-down. Utilize the services of the water treatment supplier. Maintain the maximum recommended biocide residual (for the specific biocide) for a sufficient period of time (residual and time will vary with the biocide) to bring the system under good biological control
 - or**
 - Treat the system with sodium hypochlorite to a level of 4 to 5 ppm free chlorine residual at a pH of 7.0 to 7.6. The chlorine residual must be held at 4 to 5 ppm for six hours, measurable with standard commercial water test kits.

If the evaporative condenser has been in operation and then shut down for a duration of time and not drained, perform one of the two previous biocidal treatment programs directly to the recirculating water storage vessel (collection basin, drain down tank, etc.) without circulating stagnant water over the coil(s) or operating the fan(s).

After biocidal pretreatment has been successfully completed, cooling water may be circulated over the coil(s) with the fan off.

When biocidal treatment has been maintained at a satisfactory level for at least six hours, the fan may be turned on and the system returned to service. Resume the standard water treatment program, including biocidal treatment.

operation

Operation

General:

The refrigerant condensing temperature obtained from an operating evaporative condenser will vary with the following influences:

1. **Heat load** With the fan in full operation, if the heat load increases, the condensing temperature will rise. If the heat load reduces, the condensing temperature will reduce.

The evaporative condenser establishes only the condensing temperature attainable under any operating circumstance.

2. **Air wet-bulb temperature** Condensing temperature will also vary with the wet-bulb temperature of the air entering the condenser. Reduced wet-bulb temperatures will result in lower condensing temperatures. However, the condensing temperature will not vary linearly with the wet-bulb. For example, a 20°F reduction in wet-bulb may result in only a 15°F reduction in condensing temperature.

3. **Air flow rate** Reducing air flow through the condenser causes the condensing temperature to rise. This is the recommended method by which to control condensing temperature.

If your condenser is equipped with a single-speed motor, the motor may be shut off when the condensing temperature becomes too low. This will cause the condensing temperature to rise. When the condensing temperature then becomes too warm for your process, the motor can be restarted.

Fan Cycling Limits:

Note

Considering the normal fan and motor sizes utilized on DTC evaporative condensers, anticipate that approximately 4 to 5 starts per hour are allowable.

If your evaporative condenser is equipped with a two-speed motor(s), you will have an opportunity for process temperature control. When the process fluid temperature becomes too cold, switching the fan to half-speed will cause the cold process fluid temperature to rise—stabilizing at a temperature a few degrees higher than before. With a further reduction in fluid temperature, the fan may be cycled alternately from half-speed to off.

operation

⚠ Caution

Do not start the motor(s) more than four to five times per hour (each low speed start and each high speed start count as one start).

For greater insight on cold water temperature control, please read **“Cooling Tower Energy and its Management”**, Technical Report H-001, available at spxcooling.com.

Pump cycling limits: Cycling the recirculating water pump(s) to control process fluid temperature is not typically recommended. If the recirculating water pumps(s) are cycled as part of normal system operation, care must be exercised – frequent wet/dry cycles may lead to premature scaling of the coil surface. Motor cycling limits apply.

Dry Operation

Note

Also refer to the Freezing Weather Operation and Protection Against Coil Freezing sections.

DTC evaporative condenser models may be operated dry without recirculating water during colder weather as heat load and ambient conditions permit. Dry operation is the best way to minimize the potential for ice buildup in freezing weather operation.

If dry operation is intended and the recirculating water is at risk of freezing, the recirculating pump should be turned off, and the water in the collection basin, pump and make-up supply piping should be drained. Care must be exercised when cycling the recirculating water pump(s) – frequent wet/dry cycles may lead to premature scaling of the coil surface.

Freezing Weather Operation

During operation in subfreezing weather, the opportunity exists for ice to form in the colder regions of the tower. Your primary concern is to prevent the formation of destructive ice on the cooling tower air inlet louvers. Your understanding of cold weather operation will be enhanced if you read SGS Refrigeration Technical Report H-003 **“Cooling Towers and Freezing Weather”** available at spxcooling.com.



operation

Note

It is the operator's responsibility to prevent the formation of destructive (hard) ice on the evaporative condenser air inlet louvers. Certain guidelines should be followed:

1. As cold air enters the louvers, it causes the water flowing over the coil(s) to be drawn inward toward the center of the condenser. Thus, under fan operation, the louvers and lower periphery of the condenser structure remain partly dry, seeing only random splashing from within the condenser—plus normal atmospheric moisture from the entering air. Such lightly wetted areas are most subject to freezing.

Therefore, if excessive ice forms on the louvers, stop the fan for a few minutes. With the fan off, the water flow will increase in the vicinity of the louvers and reduce the ice buildup.

2. Under extended extreme cold conditions, it may be necessary to operate the fan in reverse. This forces warm air out through the louvers, melting any accumulated ice—adequate heat load must be available. Reversal of fan should only be done at half speed or less. Reverse operation of the fan should be used sparingly and should only be used to control ice, not to prevent it. Reverse fan operation should not need to exceed 1 or 2 minutes. Monitoring is required to determine the time required to melt accumulated ice.

⚠ Warning

Operating the fan in reverse at half speed for prolonged periods during subfreezing weather can cause severe damage to fans and fan cylinders. Ice can accumulate inside fan cylinders at fan blade plane of rotation and fan blade tips will eventually strike this ring of ice, damaging the fan blades or cylinder. Ice can also accumulate on fan blades and be thrown off, damaging fan cylinder or blades. Allow a minimum of 10 minute delay between reverse operation and forward operation during subfreezing weather to permit ice to dissipate from fan blades and fan cylinders. See Fan Drive Caution note on page 10 for fan speed change and reversing precautions.

Intermittent Freezing Weather Operation:

If periods of shutdown (nights, weekends, etc.) occur during freezing weather, measures must be taken to prevent the water in the cold water basin—and all exposed pipework—from freezing. Several methods are used to combat this, including SGS Refrigeration automatic basin heater systems and pump freeze protection systems.

operation

⚠ Caution

Unless some means of freeze prevention is incorporated into your system, the evaporative condenser basin and exposed pipework should be drained at the beginning of each freezing weather shut-down period.

Note

If evaporative condenser basin is drained, verify that all basin heaters have been shut off either by automatic cutoff or disconnect switch

Water Quality and Blowdown

Maintaining Water Quality:

The steel used in DTC evaporative condensers has been galvanized with a heavy zinc coating averaging 2.0 mils in thickness. Other materials used (PVC drift eliminators and louvers, aluminum fans, cast iron Geareducer, etc.) are selected to offer maximum service life in a “normal” evaporative condenser environment, defined as follows:

Circulating water with a pH between 6.5 and 8; a chloride content (as NaCl) below 500 ppm; a sulfate content (SO_4) below 250 ppm; total alkalinity (as CaCO_3) below 500 ppm; calcium hardness (as CaCO_3) above 50 ppm; a maximum inlet water temperature not to exceed 125°F; no significant contamination with unusual chemicals or foreign substances; and adequate water treatment to minimize scaling.

- Startup Conditions: The water conditions during the initial tower operation are crucial in preventing premature corrosion of galvanized steel (white rust). For at least the first eight weeks of operation, pH should be controlled between 6.5 and 8.0 with hardness and alkalinity levels between 100 and 300 ppm (expressed as CaCO_3).
- Chlorine (if used) shall be added intermittently, with a free residual not to exceed 1 ppm—maintained for short periods. Excessive chlorine levels may deteriorate sealants and other materials of construction.
- An atmosphere surrounding the tower no worse than “moderate industrial”, where rainfall and fog are no more than slightly acid, and they do not contain significant chlorides or hydrogen sulfide (H_2S).
- Many proprietary chemicals exist for control of scale, corrosion, and biological growth and should be used prudently. Also, combinations of chemicals may cause reactions which reduce treatment effectiveness, and certain chemicals such as surfactants, biodispersants and antifoams may increase drift rate.



operation

Note

The structure and coil of your evaporative condenser consists primarily of galvanized steel, therefore your water treatment program must be compatible with zinc. In working with your water treatment supplier, it is important that you recognize the potential effects on zinc of the specific treatment program you choose.

Blowdown:

Evaporative heat exchange equipment functions by continuously causing a portion of the water circulated over the heat transfer media to evaporate. Although the water lost by evaporation is replenished by the makeup system, it exits the evaporative condenser as pure water—leaving behind its burden of dissolved solids to concentrate in the remaining water. Given no means of control, this increasing concentration of contaminants can reach a very high level.

In order to achieve water quality which is acceptable to the condenser, the selected water treatment company must work from a relatively constant level of concentrations. This stabilization of contaminant concentrations is usually accomplished by blowdown, which is the discharge of a portion of the circulating water to waste. As a rule, acceptable levels on which to base a treatment schedule will be in the range of 2-4 concentrations. If the condenser is operated at 4 concentrations, circulating water will contain four times as much dissolved solid as the makeup water, assuming none of the solids form scale or are otherwise removed from the system.

Note

When water treatment chemicals are added, they should not be introduced into the circulating water system via the cold water basin of the evaporative condenser. Water velocities are lowest at that point, which results in inadequate mixing.

Evaporative Condenser Inspection and Maintenance

⚠ Warning

Microorganisms including Legionella bacteria can exist in premise plumbing including evaporative condensers. The development of an effective water management plan (WMP) and implementation of maintenance procedures are essential to prevent the presence, dissemination and amplification of Legionella bacteria and other waterborne contaminants throughout premise plumbing. Before operating the evaporative condenser, the water management plan and maintenance procedures must be in place and regularly practiced.

operation

In addition, the following steps are recommended:

Do NOT attempt any service unless the fan motor is locked out.

- Consult a knowledgeable water treatment professional to clean and treat your cooling tower. See **Startup** section of this manual.
- Evaporative condensers must be cleaned and disinfected regularly in accordance with ASHRAE Standard 188 and Guideline 12.
- Workers performing decontamination procedures must wear personal protective equipment (PPE) as directed by their facility safety officer.
- Evaporative condensers must be visually inspected regularly to assess signs of bacterial growth, appearance of debris and scale on drift eliminators and general operating conditions. Refer to ASHRAE Standard 188 and Guideline 12 for specific frequency recommendations.
- Replace worn or damaged components.

To minimize the presence of waterborne microorganisms, including Legionella, follow the water management plan for your facility, perform regularly scheduled Evaporative condensers inspections and maintenance, and enlist the services of water treatment professionals.

For additional technical support, contact your SGS Refrigeration sales representative.

References: ashrae.org. Search “ASHRAE Standard 188” and “ASHRAE Guideline 12.” – cdc.gov. Search “Water Management Program.”

Water Collection Basin Access / Air Inlet Louver Removal:

Some maintenance procedures require access to components located in the water collection basin. These maintenance procedures can be performed from the perimeter of the evaporative condenser without entering the basin. To access the basin, one of the air inlet louver frames must be removed. To remove, loosen the thumbscrews indicated in the image below and push the louver retaining bracket up and to the left to move out of the way of the louver frame. Tip the top of the frame out from the evaporative condenser, then remove. Louver frames are not always the same size, if more than one louver



maintenance

frame is removed, the original location should be noted.

⚠ Caution

Collection basin floor has uneven surfaces and has the potential to be slippery. Care should be taken if entering the basin. Louver edges can be very sharp and could cut skin if proper protection is not used. Always wear gloves and sleeves when handling louver packs.

Access Door Operation:

⚠ Warning

Always shut off electrical power to the evaporative condenser fan motor prior to performing any inspections that may involve physical contact with the mechanical or electrical equipment in or on the evaporative condenser. Lock out and tag out any electrical switches to prevent others from turning the power back on. Service personnel must wear proper personal protective clothing and equipment.

To allow access to the mechanical system, eliminators, water distribution system and coil surface, an access door is provided toward the top of the evaporative condenser. To open, follow the following steps:

1. Remove any lock that is securing the door shut.
2. Loosen and remove the locking knob at the center of the access door panel.
3. Slide the panel with the handle sideways as far as it will travel.
4. Push the panel toward the inside of the tower. The panel will hinge to the side.



maintenance

⚠ Warning

Belt Tensioning:

Always shut off electrical power to the tower fan motor prior to performing any inspections that may involve physical contact with the mechanical or electrical equipment in or on the tower. Lock out and tag out any electrical switches to prevent others from turning the power back on. Service personnel must wear proper personal protective clothing and equipment.

On 8.5' wide models, the fan motor and belt adjustment mechanism is located outside the evaporative condenser. Remove the motor protection hood by loosening the two thumbscrews on top and hinge the hood up and out of the way.

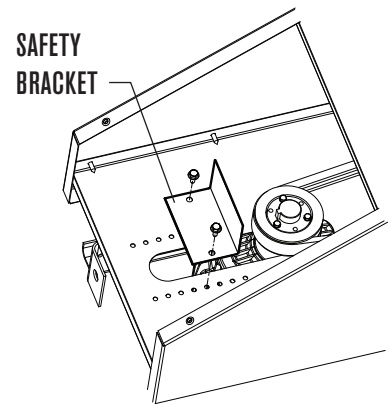

way. Also, remove the motor sheave safety bracket and set aside. See the following images.

On 10' and 12' wide models, the motor is located inside the evaporative condenser plenum. Open the access door (see Access Door Operation) and hinge out of the way.

⚠ Caution

Any bolts loosened or removed functioning as mechanical or structural

Fastener Torque Values				
Machine Bolt Size	Galvanized		Stainless	
	ft·lb _f	N·m	ft·lb _f	N·m
8mm	8	10	15	20
10mm	15	20	30	40
12mm	25	35	50	65
16mm	65	85	120	160
20mm	125	170	230	315

maintenance

al hardware should be re-placed with the torques specified below. Anti-seize compound is recommended for stainless steel hardware.

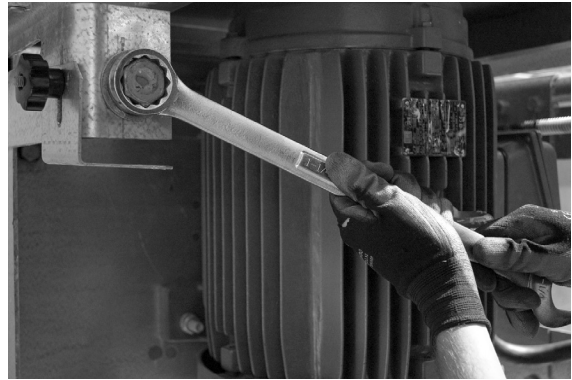

Belt tension on all models is adjusted by turning a large threaded rod(s)

that drives the motor mounting plate away from (or toward) the fan centerline. To turn the rod(s), the rod retention bracket(s) must first be moved. On the models with motors located externally, loosen the thumbscrew holding this bracket in place and rotate the bracket away from the assembly. On models with the motor located in the plenum, rod retention brackets are held in place with fasteners. Loosen fastener and slide bracket away from the adjusting rod. Turn the rod(s) clockwise to drive the motor away from the fan (tighten belts) or counterclockwise to drive the motor toward the fan (loosen the belts). On models with more than one rod, alternate turns on the rods to prevent binding. There is no need to loosen any other hardware to adjust the belt tension. After belt tension is adjusted to a satisfactory position, install



the rod retention bracket with the thumbscrew and replace any safety hoods. Ideal tension is the lowest tension at which the belt will not slip under peak load conditions. Check tension frequently during the first 24-48 hours of run-in operation. Over-tensioning shortens belt and bearing life. Keep belts free from foreign material which may cause slipping. Never apply belt dressing as this will damage the belt and cause early failure. Specific tools are made to measure the tension of a V-belt drive system. A Dodge® V-Belt Tension Tester, Browning® Belt Tension Checker or equivalent an alternative should be used

maintenance

for tensioning V-belts. Check with your local belt supplier.

Belt tension is measured by applying a force perpendicular to the belt at the center point between motor and fan sheaves. The belt should deflect $\frac{1}{64}$ " of the entire span, (measured sheave centerline to sheave centerline) when the pressure shown in the table below is applied. Because belt tension is a function of the motor sheave diameter, it is necessary to inspect the motor sheave to determine the diameter. If diameter markings are unreadable, measure the



sheave diameter at the bottom of the sheave grooves.

New belts (operating less than 8 hours) should be tensioned to the maximum value. Tension after this period should use no less than the minimum value. If the belt span was measured in inches, then use the pounds of force values. If the belt span was measured in centimeters, then use the kilograms of force values. If specific tensioning instructions are provided with your tensioning

Motor Sheave diameter	Used V-Belt minimum	New V-Belt maximum
3.4" - 4.2"	4.9 lb	7.2 lb
85cm - 105cm	2.2 kg	3.3 kg
4.4" - 5.6"	7.1 lb	10.5 lb
106cm - 140cm	3.2 kg	4.8 kg
5.8" - 8.6"	8.5 lb	12.6 lb
141 cm - 220 cm	3.9 kg	5.7 kg

tool, those instructions should be used instead.



maintenance

⚠ Warning

Sheave Alignment:

Always shut off electrical power to the tower fan motor prior to performing any inspections that may involve physical contact with the mechanical or electrical equipment in or on the tower. Lock out and tag out any electrical switches to prevent others from turning the power back on. Service personnel must wear proper personal protective clothing and equipment.

- The motor sheave is to be positioned as close as possible to the motor in order to minimize torque on the motor bushings.
- The motor and fan sheaves may have grooves that are not used. The bottom surface of the motor and fan sheaves must be aligned within $\frac{1}{8}$ " of each other and level within $\frac{1}{2}^\circ$ ($\frac{1}{8}$ " in 12") in order to not adversely affect belt and sheave life.
- Alignment can be achieved by placing a straight edge across the top of the sheaves making sure that it is level and measuring down to the bottom



surface of both sheaves at four points. See photo.

- The number of grooves on the motor and fan sheaves may not match each other, or the number of grooves on the belt. Always install the belts on the highest grooves on the fan sheave. Doing so will reduce the force

maintenance

Bushing Fastener Torque Values

Bushing	Fastener Size	Torque	
		ft·lb _f	N·m
SH	1/4 - 20	6	8
SDS	1/4 - 20	6	8
SD	1/4 - 20	6	8
SK	5/16 - 18	13	18
SF	3/8 - 16	22	30
E	1/2 - 13	35	48
F	9/16 - 12	65	88

on the fan shaft bearings, thus increasing their life.

Fan Motor Access and Removal:

Always shut off electrical power to the tower fan motor prior to performing any inspections that may involve physical contact with the mechanical or electrical equipment in or on the tower. Lock out and tag out any electrical switches to prevent others from turning the power back on. Service personnel must wear proper personal protective clothing and equipment.

⚠ Warning

The DTC fan motors are located inside or outside the evaporative condenser, depending on the model. On 8.5' wide models, the fan motor is located outside the evaporative condenser.

The motor is fully accessed by removing the motor protection hood. Remove motor protection hood and the drive belt by following the instructions in the **Belt Tensioning** section.

8.5' wide DTC models' fan motors are oriented with the shaft up. The motor may be hoisted by threading an eye bolt into the motor shaft and lifting with a hoist. To remove the motor fastener hardware, lift on the motor slightly with the hoist to remove the weight from the fasteners, then loosen and remove motor fasteners.

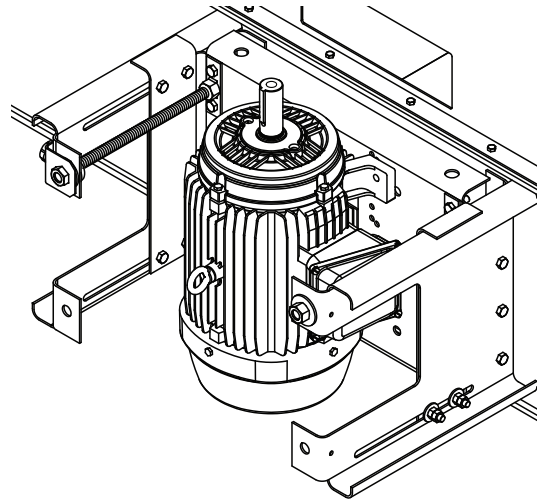

On 10' and 12' wide models, the fan motor is located inside the plenum of the evaporative condenser. The motor can be accessed through the mechanical access panel. See the **Access Door Operation** section for instructions. 

maintenance

opening the access panel. Remove the drive belt by following the instructions in the **Belt Tensioning** section.

Motor inside plenum models are equipped with either a hinged or sliding motor plate. For hinged motor plate models, loosen the motor mount system retaining bolts shown in the image. It is not necessary to loosen any hardware other than what is indicated. Hinge the motor mounting system 90° out through the access panel. Attach a hoist to the motor with straps or chains.

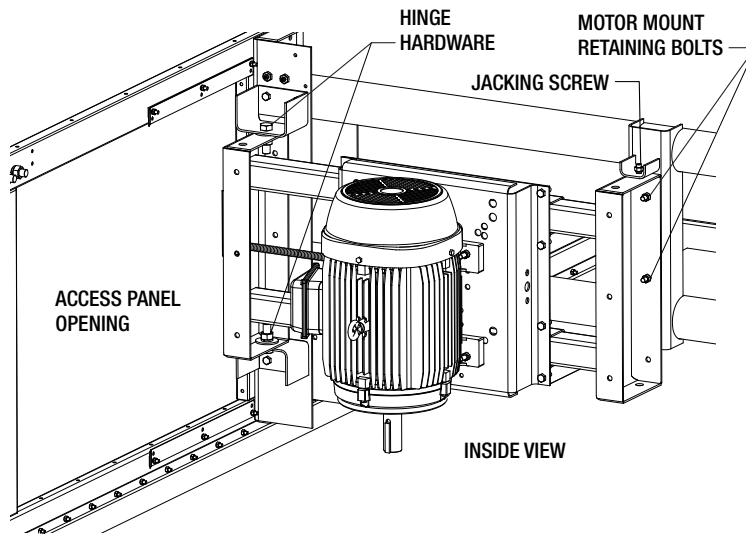

Lift on the motor slightly with the hoist to remove the weight from the motor fasteners, then loosen and remove motor fasteners.

⚠ Caution

Hoisting attachment locations vary by motor - choose strap or chain attachment locations carefully to provide a balanced lift.

For sliding motor plate models, the motor may be hoisted out through the fan cylinder opening. Turn the adjustment rod(s) counterclockwise to slide the motor toward the interior of the evaporative condenser. Remove the portion of the fan guard nearest the motor location. It may be necessary to de-pitch or remove one or more fan blades -consult the fan manual accompanying the evaporative condenser. Attach a hoist to the motor with straps or chains. Lift on the motor slightly with the hoist to remove the weight from the motor fasteners, then loosen and remove motor fasteners.

If the motor is removed from the mounting plate, it should be reinstalled at the

maintenance

Motor Mounting Bolt Torque				
Machine Bolt Size	Galvanized		Stainless	
	ft·lb _f	N·m	ft·lb _f	N·m
10mm	15	20	30	40
12mm	25	35	50	65
16mm	65	85	120	160
20mm	125	170	230	315

torques specified—do not lubricate the bolts.

Drift Eliminator Removal and Replacement:

The drift eliminators may be removed for cleaning, replacement or access to the distribution system. The eliminators are held in place by a press fit, so there is no need to remove any fasteners. However, eliminators are formed so that they nest with each other and form a monolithic barrier. Individual packs of eliminator are formed into two-foot wide sections that span from the casing wall to the centerline of the evaporative condenser, just under the mechanical torque tube.

⚠ Caution

Eliminator edges can be very sharp and can cut skin if proper protection is not used. Always wear gloves and sleeves when handling eliminator packs.



tection is not used. Always wear gloves and sleeves when handling eliminator packs.

To remove the eliminator, stand inside the access panel and lift with two

maintenance

hands on an eliminator section, this will indicate where one section stops and another starts. Lift the eliminators at that intersection, removing two packs at one time (see image). Once the first two packs are removed, the remaining packs should be easily removed. Pay close attention to the orientation and placement, they are not symmetrical. Each pack should be replaced at the location which it was removed. Repeat this process for the second half of the evaporative condenser..

Note

Proper eliminator pack replacement is essential to evaporative condenser operation. Incorrect installation may result in excessive drift rates and fan inefficiency! To ensure packs are reinstalled in the correct orientation, it is recommended that one pack is left in its original location inside the evaporative condenser as a reminder of pack orientation. Place packs in the evaporative condenser in the order they were removed. Packs should nest tightly with each other, leaving a level surface with no gaps. The last two packs should be installed at the same time. Place the final two packs according to the image on page 27, and push down to complete.

Distribution System Maintenance:

To keep your DTC evaporative condenser operating at peak performance, it may be necessary to clear the spray system of debris or sediment. To access the spray system, remove the drift eliminators as explained in the previous section. Observe the spray system with full flow on the unit. Each nozzle should produce a rectangular pattern spray which over-laps the adjacent nozzle patterns.

If a nozzle appears clogged or is not producing a proper pattern, remove the nozzle and clean all surfaces. To remove the nozzle unscrew it from the adaptor. Inspect the nozzle for cleanliness or broken pieces. If the nozzle appears broken or damaged, consult your SGS Refrigeration representative for replacement parts. Insert the nozzles by screwing it back into the adaptor.

It may also be necessary to remove an entire branch arm from the spray system. Each arm is held in place with a retention strap bolted to the branch arm supports. Remove the bolts attaching the strap to the support and pull sharply on the branch arm to disengage from the header box. It may be necessary to rotate the branch arm while pulling out from the header box.

When branch arms are removed, access to the interior of the spray header box is available to clean and remove any debris or sediment. A drain nozzle

maintenance

at the centerline of the header box is intended to drain water from the system at shutdown, as well as be removed to wash out the header box if necessary. Be sure to replace this nozzle if removed.

Reinstall the branch arms to the header, engaging them far enough to align the bolts of the tie down strap to the spray system supports. It may be necessary to wet the rubber grommet and pipe to facilitate assembly. Ensure that all nozzles are aligned to the bottom of the branch arm.

Routine Maintenance:

Some procedures may require maintenance personnel to enter the evaporative condenser. Each cell has an access door for entry into the evaporative condenser. An optional mechanical access platform is designed and intended solely for personnel to gain access to the motor and access door. Upon entering the evaporative condenser, the eliminators and coil may be used as a walking surface for inspection and typical maintenance. For those instances of frequent or prolonged servicing, it is necessary to protect the surface with plywood or planking. The fan deck and fan guard are not designed as walking or working surfaces. There are no routine maintenance procedures that require access to top of the evaporative condenser.

⚠ Warning

The purchaser or owner is responsible for providing a safe method for entering or exiting the access door.

Included with the instruction packet are separate User Manuals on each major operating component of the evaporative condenser, and it is recommended that you read them thoroughly. Where discrepancies may exist, the separate User Manuals will take precedence. The following is recommended as a minimum routine of scheduled maintenance:

⚠ Warning

Always shut off electrical power to the tower fan motor prior to performing any inspections that may involve physical contact with the mechanical or electrical equipment in or on the tower. Lock out and tag out any electrical switches to prevent others from turning the power back on. Service personnel must wear proper personal protective clothing and equipment.

Weekly Visually inspect the evaporative condenser to assess general operating conditions and for signs of microbial growth and appearance of debris,



maintenance

scale and corrosion. Refer to ASHRAE Standard 188 and Guideline 12 for specific frequency recommendations. Consult a knowledgeable water treatment professional to maintain evaporative condenser hygiene.

Monthly (Weekly at start up) Observe, touch, and listen to the evaporative condenser. Become accustomed to its normal appearance, sound, and level of vibration. Abnormal aspects relating to the rotating equipment should be considered reason to shut down the evaporative condenser until the problem can be located and corrected. Observe operation of the motor, coupling (or drive shaft) and Geareducer (if equipped), belt and sheaves (if equipped), and fan. Become familiar with the normal operating temperature of the motor(s), as well as the sight and sound of all components as a whole.

If equipped, check Geareducer oil level. Shut down the unit and allow 5 minutes for the oil level to stabilize. Add oil if required. Check for Geareducer oil leaks. Check the Geareducer as well as any optional oil lines to external oil dipstick/sight glass.

Inspect louvers, drift eliminators and basin trash screens and remove any debris or scale which may have accumulated. Replace any damaged or worn out components. Use of high-pressure water may damage the eliminator and louver material.

Observe operation of the float valve. Depress the operating lever to make sure that the valve is operating freely. Inspect the suction screen for plugging. Remove any debris that may have accumulated.

Check for any buildup of silt on the floor of the collection basin. Mentally make note of the amount, if any, so future inspections will enable you to determine the rate at which it is forming.

View the water pattern as it exits the coil section. Consistent coverage indicates that all nozzles are flowing properly. If there are dry spot in the coil or inconsistent coverage, this may be evidence of a clogged nozzle. Inspect nozzles for blockage.

Every 3 months If equipped, lubricate fan shaft bearings. Each cell is equipped with extended lube lines protruding through the casing adjacent to the access door. While rotating equipment by hand, grease the bearings until a bead forms around the seals—a maximum charge of 0.75 ounces is recommended. Chevron SRI-2 grease (or equivalent lithium-based



maintenance

grease) is recommended.

Semi-Annually If equipped, check the belt tension and condition. Adjust tension as necessary.

Note

Geareducer models used on DTC evaporative condensers are designed for 5-year oil change intervals. To maintain five-year change intervals, use only oil designed specifically for these Geareducers. If, after five years, turbine-type mineral oil is used, the oil must be changed semiannually. Refer to the “Geareducer User Manual” for oil recommendations and further instructions.

Annually Inspect the evaporative condenser thoroughly, making maximum use of instructions given in the separate User Manuals. Check structural bolted connections and tighten as required. Make preventive maintenance repairs as necessary.

Lubricate motor(s) according to the manufacturer's instructions. See instructions following for evaporative condensers with geareducer drive and motor located outside the plenum. Fan motors with sealed bearings do not require lubrication maintenance.

Note

If the motor has sealed bearings, additional lubrication is not required. Refer to the motor nameplate to determine if grease type and amount are specified.

Check to see that all bolts are tight in the fan and mechanical equipment region, including the fan cylinder and fan guard. Refer to Component User Manuals for torque values.

Every 5 Years: If equipped, change Geareducer oil. Refer to the **Geareducer User Manual** for instructions.

Motor Lubrication Instructions:

Geareducer drive with motor located outside plenum. Not required for motors with sealed bearings

Warning

Open and lock out disconnect switch to make certain motor cannot be started.

1. Remove guard as shown. Opposite end motor bearing is accessible from outside the evaporative condenser.



maintenance

2. Remove grease fill and relief plugs at both shaft extension end and opposite end bearings and remove hardened grease, using clean wire.
3. Insert grease fittings in grease fill openings and add grease until grease is forced out through relief openings.
4. Replace fill plugs and operate mechanical equipment 30 minutes to one hour to purge excess grease at grease relief opening.
5. Reinstall grease relief plugs and reinstall guard.

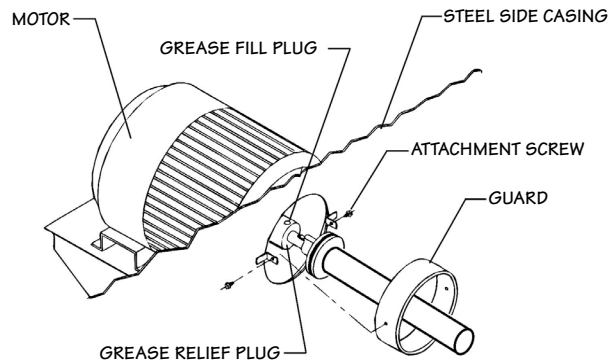

6. Resume normal evaporative condenser operation.

Seasonal Shutdown Instructions

When the system is to be shut down for an extended period of time, it is recommended that the recirculating water system be drained. Leave the basin drains open.

During shutdown, follow recommendations in the **Evaporative Condenser Inspection and Maintenance** section of this manual before attempting repairs. Eliminators and louvers can be removed to gain access to the coil. Pay particular attention to mechanical equipment supports and sheaves or coupling (or drive shafts).

Following each year's shutdown and cleaning, inspect the evaporative condenser's metal surfaces for evidence of the need to apply a protective coating. Do not misinterpret grime as a need to have the evaporative condenser painted. If relatively bright metal can be exposed by cleaning, consider that the galvanizing has remained effective. Unless there is evidence of a generalized failure of the galvanizing, localized touch-up should be all that is required.

Note

To the extent that the galvanizing (zinc coating) still exists, paint will not adhere to it readily. Contact the manufacturer of the coating

maintenance

you intend to use for instructions.

Evaporative condenser framework Check structural bolted connections and tighten as required.

Fans: Check fan assembly bolting and tighten as required. Use torque values prescribed in the **Fan User Manual**.

Fans shaft bearings If equipped, lubricate fan shaft bearings at close of each operating season—see page 33.

Fan motors Clean and lubricate motor (if required) at close of each operating season (refer to motor manufacturer's recommendations.) Does not apply to motors with sealed bearings. Check motor anchor bolts and tighten as required. See Page 35 for evaporative condensers with motor located outside the plenum option.

⚠ Caution

Do not start motor before determining that there will be no interference with free rotation of the fan drive.

The motor should be operated for three hours at least once a month. This serves to dry out windings and lubricate bearing surfaces. Refer to SGS Refrigeration “**Fan Motor**” User Manual Z0239042 for additional information.

At start of new operating season, make sure bearings are adequately lubricated before returning motor to service. Does not apply to motors with sealed bearings.

Long Term Storage Procedures:

Instructions for protection of non-operating equipment for more than 3 months.

After installation of the DTC evaporative condenser and completion of the pre-startup instructions, the operational availability of equipment will last for a maximum period of three months. Ensure that the condenser is completely drained of all water and the drain is open. Coils should remain charged with nitrogen until put in service.

After this initial period of 3 months, until the unit is employed into continuous operation, the fan shaft should be turned by hand for a few minutes every month after: Inject a small amount of grease into ball /roller bearings of fan shaft and drive components as per the manufacturer's recommendation attached.

General Protective Requirements for Evaporative condensers The fan opening at the top of the evaporative condenser should be covered with a tarp. This will protect the mechanical components from rain as well as keep

maintenance

out dirt, trash, leaves, etc.

All coils on every evaporative condenser model are protected from the environment by the structure of the evaporative condenser as well as the PVC air inlet louvers. No external protection of the coil is required for long-term storage.

Internal Protection of Coil: All of the coil inlet and outlet connections should be sealed off and the coils should be charged with nitrogen gas to prevent corrosion. Condenser coils from the factory are charged with nitrogen to approximately 20 psig. No external protection of the coil is required for long-term storage.

Mechanical Components:

Electric motors All drive motors should be taken down and stored indoors. Then, every month, turn motor shafts to evenly distribute lubricant to the bearing parts.

Recirculation Pumps All pumps and pump motors should be taken down and stored indoors (pumps and motors may be stored fully assembled). Then, every month, turn pump impeller shaft to evenly distribute lubricant to the bearing parts.

Belts Properly stored belts will retain their properties unchanged for several years. Under unfavorable storage conditions and with improper handling, deterioration of their physical properties will result. These changes can be caused by, for example, oxidation, ozone, extreme temperatures, light, damp or solvents. It should be ensured that belts are stored stress free, which is to say without tension, pressure or other causes of deformation, as strain causes permanent deformation and failure due to fatigue, as well as cracking. If, for reasons of space, they are stored suspended, the diameter of the bar from which they are suspended must be equal to at least 10 times the height of the belt. The belts may not be stored for longer than 3 months in an open, uncontrolled environment. The storage area must be dry and dust-free. Belts may not be kept together with chemicals, solvents, fuels, lubricants, acids, etc.

Belts should be shielded from radiators and their pipes. The distance between radiators and stored equipment must be at least 10 feet.

Belts should be protected from light, particularly from direct sunlight and strong artificial light with high ultraviolet content (formation of ozone), such as for example fluorescent tubes installed in open fixtures. Ideally, room lighting should be normal incandescent bulbs.

To counteract the damaging effect of ozone, the storage areas may not contain any form of ozone generating equipment, such as for example fluorescent light sources, mercury vapor lamps or electrical high voltage devices. Combustion gases and vapors, which may lead to ozone formation due to chemical

maintenance

processes, must be avoided or removed.

Damp storage areas are quite unsuitable. It should be ensured that no condensation occurs. The relative humidity should be below 65 %.

Cleaning of dirty belts can be carried out with a mixture of glycerin and spirit in a ratio of 1:10.

Caution

Benzene, benzol, turpentine and similar substances may not be used. Furthermore, sharp objects, wire brushes, emery paper etc., may not be used, as they will cause mechanical damage to the belts.

Bearings Every month, turn the fan shaft and rotate by hand to distribute grease evenly over the bearing parts. Then, every three months, inject grease to prevent any blocking of the lubrication lines possibly due to grease hardening. Whenever the fan shaft has been turned, it is a must to secure them at a standstill.

Fans See **Fan User Manual** for instructions.

SPX Cooling Technologies Services

Our interest in your DTC evaporative condenser does not end with the sale. Having designed and manufactured one of the most reliable and longest-lasting evaporative condensers in its class, we want to make sure that you gain the maximum possible benefit from its purchase.

Therefore, the following services are available which are intended to: assure the maximum possible service life under your operating conditions; tailor the operating characteristics to your specific needs—and maintain consistently optimum thermal performance capability. They are available by contacting your Mar-ley sales representative.

Replacement Parts A complete stock of parts and components is maintained at one or more of the various manufacturing plants. In cases of emergency, they can normally be shipped within 24 hours—by air freight if necessary. However, you would obviously benefit from anticipating your need in advance, thus avoiding the cost of special handling.

Be sure to mention your evaporative condenser serial number (from the evaporative condenser nameplate) when ordering parts.

Periodic Maintenance You may wish to contract with SPX Cooling for regularly scheduled visits—for the purpose of inspecting and reporting your evaporative condenser's condition—to make recommendations intended to pre-



additional information

vent emergencies— and to perform maintenance considered outside the norm. This service is not intended to replace the important function performed by your maintenance staff. Their attention assures the evaporative condenser's routine operating performance, and is invaluable. However, we recognize that the unusual manner in which a evaporative condenser performs its function— as well as the unique forces which act upon it—may be considerations which occasionally require the services of an expert technician.

Increased Load Requirements DTC evaporative condensers are designed so that cells of either equal or unequal capacity can be added in the future. This allows you to compensate for the load increases that normally occur with the replacement or addition of production equipment—and still retain continuity with respect to your evaporative condenser system.

Evaporative Condenser Rebuilding SPX routinely rebuilds and upgrades evaporative condensers, evaporative condensers and cooling towers of all materials and manufacture. If your product ever reaches the limit of its service life, we recommend that you investigate the cost of rebuilding before you routinely order a new replacement evaporative condenser.

Each DTC evaporative condenser includes a document package containing general orientation drawings, assembly instructions and evaporative condenser component manuals. **These documents contain important information relating to safe installation and operation of the evaporative condenser.** Field installation is required for motors and motor supports on motor outside plenum models and piping inlets and outlets. Some optional accessories, such as access platforms, ladders and safety cages may also require field installation. A separate installation drawing or manual for each purchased option is included in the document package along with bills of material. If you have purchased an option and can't find the appropriate installation drawing, contact your local sales representative before proceeding.

In addition to these specific documents, numerous technical reports are published by SPX including more detailed information on a variety of evaporative heat rejection equipment operation and service topics. Your SGS Refrigeration sales representative will be happy to give you copies of these reports at no charge or you can download copies from our website at spxcooling.com. For complete parts and service assistance, contact the SGS Refrigeration sales representative in your area. If you need help locating your representative, please phone 913 664 7400 or check the internet at spxcooling.com.

maintenance schedule

Maintenance Service	Monthly	Semi-annually	Seasonal Startup or Annually
Inspect General Condition and Operation	x		x
Observe Operation of:			
Mechanical—motor, fan and drive mechanism	x		x
Makeup valve (if equipped)	x		x
Inspect for unusual noise or vibration	x		x
Inspect and Clean:			
Air inlet	x		x
PVC drift eliminators	x		x
Nozzles	x		x
Collection Basin	x		x
Fan and pump motor exterior	x		x
Coil surface		x	
Check:			
Collection water basin level	x		x
Blowdown—adjust as required	x		x
Gearreducer Drive (if equipped):			
Check for loose fasteners including oil drain plug			x
Check oil level, check for / repair oil leaks	x		x
Change oil		R	
Make sure vent is open		x	x
Check driveshaft or coupling alignment			x
Check for loose driveshaft or coupling fasteners			x
Check driveshaft or coupling bushings or flex element for unusual wear		x	x
Lube lines (if equipped):			
Check for oil leaks in hoses or fittings	x	R	x
Belt drive (if equipped):			
Fan shaft bearing lubrication (every 3 mo.)		every 3 months	every 3 months
Check and tighten support fasteners			x
Check shaft, sheave and belt alignment			x
Check belt tension and condition		x	x
Check sheave bushing fastener torque			x
Fan:			
Check and tighten blade and hub fasteners			x
Check fan blade pitch and tip clearance			x
Check fan cylinder for loose fasteners			x
Motor:			
Lubricate (as required)			R
Check mounting bolts for tightness			x
Operate at least	3 hours a month	3 hours a month	3 hours a month
Basin Heater (if equipped):			
Check for proper operation of temp/low water level sensor			x
Inspect/clean buildup of contaminant from sensor		x	x
Structure:			
Inspect/tighten all fasteners		x	x
Inspect and touch up all metal surfaces			x

R — Refer to Component User Manual

Note: It is recommended at least weekly, that the general operation and condition be observed. Pay attention to any changes in sound or vibration that may signify a need for closer inspection.

troubleshooting

Trouble	Cause	Remedy
Motor will not start	Power not available at motor terminals	Check power at starter. Correct any bad connections between the control apparatus and the motor. Check starter contacts and control circuit. Reset overloads, close contacts, reset tripped switches or replace failed control switches. If power is not on all leads at starter, make sure overload and short circuit devices are in proper condition
	Wrong connections	Check motor and control connections against wiring diagrams.
	Low voltage	Check nameplate voltage against power supply. Check voltage at motor terminals.
	Open circuit in motor winding	Check stator windings for open circuits.
	Motor or fan drive stuck	Disconnect motor from load and check motor and fan drive for cause of problem.
	Rotor defective	Look for broken bars or rings.
Unusual motor noise	Motor running single-phase	Check motor and attempt to start it. Motor will not start if single-phased. Check wiring, controls and motor.
	Motor leads connected incorrectly	Check motor connections against wiring diagram on motor.
	Bad bearings	Check lubrication. Replace bad bearings.
	Electrical unbalance	Check voltages and currents of all three lines. Correct if required.
	Air gap not uniform	Check and correct bracket fits or bearing.
	Rotor unbalance	Rebalance
Motor runs hot	Cooling fan hitting end belt guard	Reinstall or replace fan.
	Wrong voltage or unbalanced voltage	Check voltage and current of all three lines against nameplate values.
	Overload	Check fan blade pitch. See "Fan User Manual." Check for drag in fan drivetrain as from damaged bearings.
	Wrong motor RPM	Check nameplate against power supply. Check RPM of motor and drive ratio.
	Bearing overgreased	Remove bearing reliefs. Run motor up to speed to purge excessive grease. Does not apply to motors with sealed bearings.
	Wrong lubricant in bearings	Change to proper lubricant. See motor manufacturer's instructions.
	One phase open	Stop motor and attempt to start it. Motor will not start if single-phased. Check wiring, controls and motor.
	Poor ventilation	Clean motor and check ventilation openings. Allow ample ventilation around motor.
	Winding fault	Check with ohmmeter.
	Bent motor shaft	Straighten or replace shaft.
Motor runs hot	Insufficient grease	Remove plugs and regrease bearings. Does not apply to motors with sealed bearings.
	Too frequent starting or speed changes	Limit cumulative accelerations time to a total of 30 seconds/hour. Set on/off or speed change set points farther apart. Consider installing a SGS Refrigeration VFD drive for fine temperature control.
	Deterioration of grease or foreign material in grease	Flush bearings and relubricate. Does not apply to motors with sealed bearings.
	Bearings damaged	Replace bearings.

troubleshooting

Trouble	Cause	Remedy
Motor does not come up to speed	Voltage too low at motor terminals because of line drop	Check transformer and setting of taps. Use higher voltage on transformer terminals or reduce loads. Increase wire size or reduce inertia.
	Broken rotor bars	Look for cracks near the rings. A new rotor may be required. Have motor service person check motor.
Wrong motor rotation	Wrong sequence of phases	Switch any two of the three motor leads.
Geareducer noise. (If equipped).	Geareducer bearings	If new, see if noise disappears after one week of operation. Drain flush, and refill Geareducer oil. See "Geareducer User Manual." If still noisy, replace.
	Gears	Correct tooth engagement. Replace badly worn gears. Replace gears with broken or damaged teeth.
Unusual fan drive vibration	Loose bolts and cap screws	Tighten all bolts and cap screws on all mechanical equipment and supports.
	Unbalanced drive shaft or worn couplings. (If equipped)	Make sure motor and Geareducer shafts are in proper alignment and "match marks" properly matched. Repair or replace worn couplings. Rebalance drive shaft by adding or removing weights from balancing cap screws. See "Driveshaft User Manual."
	Fan	Make certain all blades are as far from center of fan as safety devices permit. All blades must be pitched the same. See "Fan User Manual." Clean off deposit build-up on blades
	Worn Geareducer bearings. (If equipped)	Check fan and pinion shaft endplay. Replace bearings as necessary.
	Worn fan shaft bearings. (Belt drive).	Check fan shaft endplay. Replace bearings as necessary.
	Unbalanced motor	Disconnect load and operate motor. If motor still vibrates, rebalance rotor.
	Bent Geareducer shaft. (If equipped).	Check fan and pinion shaft with dial indicator. Replace if necessary.
Fan noise	Blade rubbing inside of fan cylinder	Adjust cylinder to provide blade tip clearance
	Loose bolts in blade clamps	Check and tighten if necessary.
	Fan shaft bearing. (Belt drive).	Grease bearings.
Scale or foreign substance in circulating water system	Insufficient blowdown	See "Water Treatment" section of this manual.
	Water treatment deficiency	Consult competent water treating specialist. See "Water Treatment" section of this manual
Condensing temperature too warm. See "Evaporative Condenser Operation."	Entering wet bulb temperature is above design	Check to see if local heat sources are affecting evaporative condenser. See if surrounding structures are causing recirculation of evaporative condenser discharge air. Discuss remedy with SGS Refrigeration representative.
	Design wet bulb temperature was too low.	May have to increase evaporative condenser size. Discuss remedy with SGS Refrigeration representative
	Actual process load greater than design	May have to increase evaporative condenser size. Discuss remedy with SGS Refrigeration representative
	Overpumping	Reduce water flow rate over evaporative condenser to design conditions.
	Evaporative condenser starved for air	Check motor current and voltage to be sure of correct contract horsepower. Repitch fan blades if necessary. Clean eliminators. Check to see if nearby structures or enclosing walls are obstructing normal airflow to evaporative condenser. Discuss remedy with SGS Refrigeration representative.
Excessive drift exiting evaporative condenser	Spray system malfunction	Inspect spray system for proper operation. Correct as necessary.
	Faulty drift elimination	Check to see that the eliminators are clean, free of debris and installed correctly. Clean if necessary. Replace damaged or worn out components.

DTC evaporative condenser

USER MANUAL

SPX COOLING TECH, LLC

827 WEST PROGRESS DRIVE
DIXON, IL 61021 USA
815 284 2700 | spxcooling@spx.com
spxcooling.com

Z0921107_D | ISSUED 06/2024

©2024 SPX COOLING TECH, LLC | ALL RIGHTS RESERVED.

In the interest of technological progress, all products are subject to design and/or material change without notice.

