

# MarleyGard CD controller supplemental

BACNET COMMUNICATIONS

Z1069147 ISSUED 4/2018

READ AND UNDERSTAND THIS MANUAL PRIOR TO OPERATING OR SERVICING THIS PRODUCT.

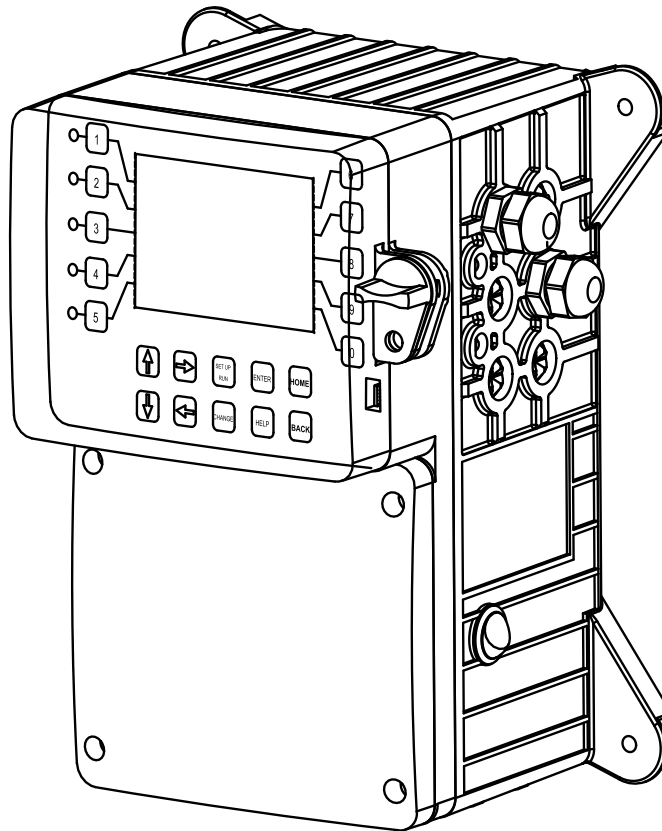

---

## contents

BACnet Introduction .....	3
BACnet Overview .....	3
Protocol Implementation Summary (Annex-A) .....	3
MarleyGard CD Controller Setup .....	4
Object Definitions .....	5
Object / Property Support Matrix.....	5
Binary Input Object Instance Summary.....	6
Binary Value Object Instance Summary .....	6
Analog Input Object Instance Summary .....	14
Analog Value Object Instance Summary.....	15
Multi-State Value Object Instance Summary .....	18

---

# introduction

---

## **BACnet**

The MarleyGard controller is capable of connecting to the WebAdvantage Server and most Building Management Systems. The WebAdvantage service requires a gateway to the internet with firewall and security rules in place. The Building Management System needs to be on the same subnet to properly receive traffic from the MarleyGard controller. This may require some advanced routing of network traffic within the network wiring or programming of advanced switching equipment. The data traffic for both is provided via the same Ethernet cable coming from the MarleyGard controller.

The BACnet protocol allows interfacing with more customizable PC applications using HMI/SCADA and stand-alone HMI systems

---

## **BACnet Overview**

BACnet is an American National Standard. The BACnet protocol allows the creation of an automation and controls system which may interoperate with other BACnet systems. In BACnet terms, interoperate means that two or more BACnet-speaking computer systems may share the same communications networks, and ask each other to perform various functions on a peer-to-peer basis.

BACnet's flexibility has two important benefits: vendor-independence and forward-compatibility with future generations of systems. This is accomplished using an object-oriented approach for representing all information within each controller. Since BACnet is based on standards, it provides maximum benefits for both the vendor who designs BACnet systems, and the specifier or owner of those systems.

---

## **Protocol Implementation Conformance Summary (Annex-A)**

**Applications Software Version:** JA.12.1 and higher

**Firmware Revision:** JA.12.1 and higher

**BACnet Protocol Revision:** 5

**BACnet Standardized Device Profile (Annex L):** BACnet Application Specific Controller (B-ASC) BACnet Interoperability Building Blocks Supported (Annex K):

- DS-RP-B
- DM-DDB-B
- DM-DCC-B
- DM-RD-B

**Standard Object Types Supported:** See table 3-1 "Object/Property Support Matrix".

**Data Link Layer Options:** BACnet IP, (Annex J)

**Character Set Supported:** ANSI X3.4

# setup

## MarleyGard CD Setup

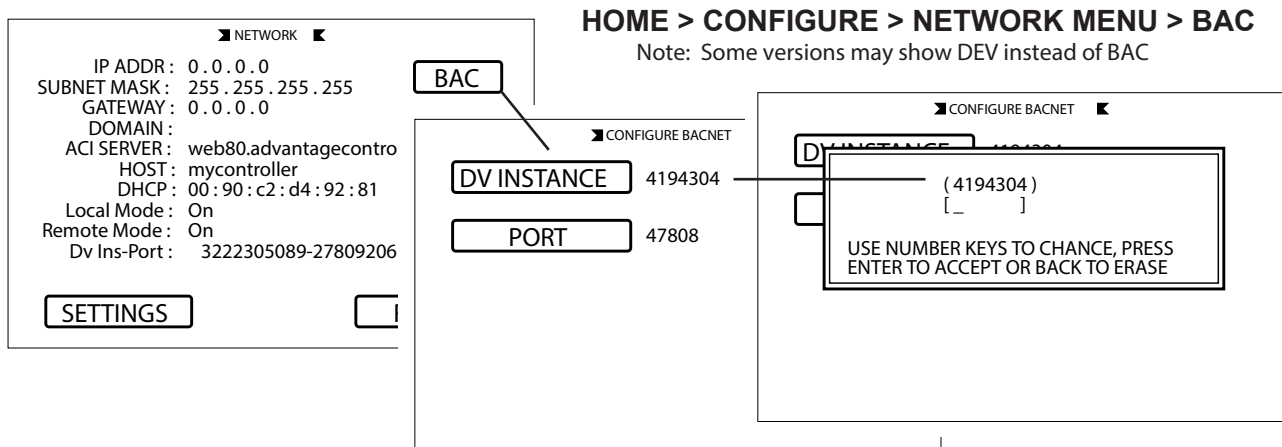

The MarleyGard CD controller will be a “device object” on the particular BACnet network. Each device object (your MarleyGard controller) must have an object identifier that is unique network wide. The device object instance number is normally configured on site after the device is installed. The device object instance number range is between 0 and 4194303. Note that 4194303 is known as “unconfigured” and is not really a valid device instance number. All devices are required to respond with their own Device object instance number when 4194303 is requested.

To enter your device object identifier, go to the Configure menu in the MarleyGard controller and select the Network settings. Then select BAC.

## object definitions

**Object / Property Support Matrix** Table 1-1

Property	Object Type					
	Device	Binary Input	Binary Value	Analog Input	Analog Value	Multi-State Value
Object Identifier	✓	✓	✓	✓	✓	✓
Object Name	✓	✓	✓	✓	✓	✓
Object Type	✓	✓	✓	✓	✓	✓
Description	✓	✓	✓	✓	✓	✓
System Status	✓					
Vendor Name	✓					
Vendor Identifier	✓					
Model Name	✓					
Firmware Revision	✓					
App. Software Revision	✓					
Protocol Version	✓					
Protocol Revision	✓					
Services Supported	✓					
Object Types Supported	✓					
Object List	✓					
Max APDU Length	✓					
Segmentation Support	✓					
APDU Timeout	✓					
Number APDU Retries	✓					
Database Revision	✓					
Present Value		✓	✓	✓	✓	✓
Status Flags		✓	✓	✓	✓	✓
Event State		✓	✓	✓	✓	✓
Out-of-Service		✓	✓	✓	✓	✓
Units				✓	✓	
Polarity		✓	✓			
Number of States						✓
State Text						✓

---

## object definitions

---

**Binary Input Object Instance Summary Table 1-2**

Instance ID	Object Name	Purpose	Present Value – Access
0	BI-000	System #1 – Flow Switch	Read Only
1	BI-001	System #2 – Flow Switch	Read Only
2	BI-002	System #3 – Flow Switch	Read Only
3	BI-003	System #4 – Flow Switch	Read Only

---

**Binary Value Object Instance Summary Table 1-3**

Instance ID	Object Name	Purpose	Present Value – Access
0	BV-000	System #1 – Conductivity Alarm	Read Only
1	BV-001	System #1 – pH Alarm	Read Only
2	BV-002	System #1 – ORP Alarm	Read Only
3	BV-003	System #1 – S. Temp Alarm	Read Only
4	BV-004	System #1 – M. Temp Alarm	Read Only
5	BV-005	System #1 – D. Temp Alarm	Read Only
6	BV-006	System #1 – Timer 1 Alarm	Read Only
7	BV-007	System #1 – Timer 2 Alarm	Read Only
8	BV-008	System #1 – Timer 3 Alarm	Read Only
9	BV-009	System #1 – Timer 4 Alarm	Read Only
10	BV-010	System #1 – Timer 5 Alarm	Read Only

## object definitions

11	BV-011	System #1 – All Alarms	Read Only
12	BV-012	System #1 – Conductivity High Alarm	Read Only
13	BV-013	System #1 – Conductivity Low Alarm	Read Only
14	BV-014	System #1 – Conductivity Limit Alarm	Read Only
15	BV-015	System #1 – pH High Alarm	Read Only
16	BV-016	System #1 – pH Low Alarm	Read Only
17	BV-017	System #1 – pH Limit Alarm	Read Only
18	BV-018	System #1 – ORP High Alarm	Read Only
19	BV-019	System #1 – ORP Low Alarm	Read Only
20	BV-020	System #1 – ORP Limit Alarm	Read Only
21	BV-021	System #1 – S. Temp High Alarm	Read Only
22	BV-022	System #1 – S. Temp Low Alarm	Read Only
23	BV-023	System #1 – M. Temp High Alarm	Read Only
24	BV-024	System #1 – M. Temp Low Alarm	Read Only
25	BV-025	System #1 – D. Temp High Alarm	Read Only
26	BV-026	System #1 – D. Temp Low Alarm	Read Only
27	BV-027	System #1 – No Flow Alarm	Read Only
28	BV-028	System #1 – Digital Input 1 Alarm	Read Only
29	BV-029	System #1 – Digital Input 2 Alarm	Read Only
30	BV-030	System #1 – Digital Input 3 Alarm	Read Only
31	BV-031	System #1 – Digital Input 4 Alarm	Read Only
32	BV-032	System #1 – Digital Input 5 Alarm	Read Only
33	BV-033	System #1 – M. Conductivity Alarm	Read Only
34	BV-034	System #1 – M. Conductivity High Alarm	Read Only
35	BV-035	System #1 – M. Conductivity Low Alarm	Read Only
36	BV-036	System #1 – M. Conductivity Limit Alarm	Read Only
37	BV-037	System #1 – Notepad 1 High Alarm	Read Only
38	BV-038	System #1 – Notepad 2 High Alarm	Read Only
39	BV-039	System #1 – Notepad 3 High Alarm	Read Only
40	BV-040	System #1 – Notepad 4 High Alarm	Read Only
41	BV-041	System #1 – Notepad 5 High Alarm	Read Only
42	BV-042	System #1 – Notepad 6 High Alarm	Read Only
43	BV-043	System #1 – Notepad 7 High Alarm	Read Only
44	BV-044	System #1 – Notepad 8 High Alarm	Read Only
45	BV-045	System #1 – Notepad 9 High Alarm	Read Only
46	BV-046	System #1 – Notepad 10 High Alarm	Read Only
47	BV-047	System #1 – Notepad 1 Low Alarm	Read Only
48	BV-048	System #1 – Notepad 2 Low Alarm	Read Only
49	BV-049	System #1 – Notepad 3 Low Alarm	Read Only
50	BV-050	System #1 – Notepad 4 Low Alarm	Read Only
51	BV-051	System #1 – Notepad 5 Low Alarm	Read Only

## object definitions

52	BV-052	System #1 – Notepad 6 Low Alarm	Read Only
53	BV-053	System #1 – Notepad 7 Low Alarm	Read Only
54	BV-054	System #1 – Notepad 8 Low Alarm	Read Only
55	BV-055	System #1 – Notepad 9 Low Alarm	Read Only
56	BV-056	System #1 – Notepad 10 Low Alarm	Read Only
57	BV-057	System #1 – Notepad 1 Time Alarm	Read Only
58	BV-058	System #1 – Notepad 2 Time Alarm	Read Only
59	BV-059	System #1 – Notepad 3 Time Alarm	Read Only
60	BV-060	System #1 – Notepad 4 Time Alarm	Read Only
61	BV-061	System #1 – Notepad 5 Time Alarm	Read Only
62	BV-062	System #1 – Notepad 6 Time Alarm	Read Only
63	BV-063	System #1 – Notepad 7 Time Alarm	Read Only
64	BV-064	System #1 – Notepad 8 Time Alarm	Read Only
65	BV-065	System #1 – Notepad 9 Time Alarm	Read Only
66	BV-066	System #1 – Notepad 10 Time Alarm	Read Only
67	BV-067	System #1 – pH 2 Alarm	Read Only
68	BV-068	System #1 – ORP 2 Alarm	Read Only
69	BV-069	System #2 – Conductivity Alarm	Read Only
70	BV-070	System #2 – pH Alarm	Read Only
71	BV-071	System #2 – ORP Alarm	Read Only
72	BV-072	System #2 – S. Temp Alarm	Read Only
73	BV-073	System #2 – M. Temp Alarm	Read Only
74	BV-074	System #2 – D. Temp Alarm	Read Only
75	BV-075	System #2 – Timer 1 Alarm	Read Only
76	BV-076	System #2 – Timer 2 Alarm	Read Only
77	BV-077	System #2 – Timer 3 Alarm	Read Only
78	BV-078	System #2 – Timer 4 Alarm	Read Only
79	BV-079	System #2 – Timer 5 Alarm	Read Only
80	BV-080	System #2 – All Alarms	Read Only
81	BV-081	System #2 – Conductivity High Alarm	Read Only
82	BV-082	System #2 – Conductivity Low Alarm	Read Only
83	BV-083	System #2 – Conductivity Limit Alarm	Read Only
84	BV-084	System #2 – pH High Alarm	Read Only
85	BV-085	System #2 – pH Low Alarm	Read Only
86	BV-086	System #2 – pH Limit Alarm	Read Only
87	BV-087	System #2 – ORP High Alarm	Read Only
88	BV-088	System #2 – ORP Low Alarm	Read Only
89	BV-089	System #2 – ORP Limit Alarm	Read Only
90	BV-090	System #2 – S. Temp High Alarm	Read Only
91	BV-091	System #2 – S. Temp Low Alarm	Read Only
92	BV-092	System #2 – M. Temp High Alarm	Read Only



## object definitions

52	BV-052	System #1 – Notepad 6 Low Alarm	Read Only
53	BV-053	System #1 – Notepad 7 Low Alarm	Read Only
54	BV-054	System #1 – Notepad 8 Low Alarm	Read Only
55	BV-055	System #1 – Notepad 9 Low Alarm	Read Only
56	BV-056	System #1 – Notepad 10 Low Alarm	Read Only
57	BV-057	System #1 – Notepad 1 Time Alarm	Read Only
58	BV-058	System #1 – Notepad 2 Time Alarm	Read Only
59	BV-059	System #1 – Notepad 3 Time Alarm	Read Only
60	BV-060	System #1 – Notepad 4 Time Alarm	Read Only
61	BV-061	System #1 – Notepad 5 Time Alarm	Read Only
62	BV-062	System #1 – Notepad 6 Time Alarm	Read Only
63	BV-063	System #1 – Notepad 7 Time Alarm	Read Only
64	BV-064	System #1 – Notepad 8 Time Alarm	Read Only
65	BV-065	System #1 – Notepad 9 Time Alarm	Read Only
66	BV-066	System #1 – Notepad 10 Time Alarm	Read Only
67	BV-067	System #1 – pH 2 Alarm	Read Only
68	BV-068	System #1 – ORP 2 Alarm	Read Only
69	BV-069	System #2 – Conductivity Alarm	Read Only
70	BV-070	System #2 – pH Alarm	Read Only
71	BV-071	System #2 – ORP Alarm	Read Only
72	BV-072	System #2 – S. Temp Alarm	Read Only
73	BV-073	System #2 – M. Temp Alarm	Read Only
74	BV-074	System #2 – D. Temp Alarm	Read Only
75	BV-075	System #2 – Timer 1 Alarm	Read Only
76	BV-076	System #2 – Timer 2 Alarm	Read Only
77	BV-077	System #2 – Timer 3 Alarm	Read Only
78	BV-078	System #2 – Timer 4 Alarm	Read Only
79	BV-079	System #2 – Timer 5 Alarm	Read Only
80	BV-080	System #2 – All Alarms	Read Only
81	BV-081	System #2 – Conductivity High Alarm	Read Only
82	BV-082	System #2 – Conductivity Low Alarm	Read Only
83	BV-083	System #2 – Conductivity Limit Alarm	Read Only
84	BV-084	System #2 – pH High Alarm	Read Only
85	BV-085	System #2 – pH Low Alarm	Read Only
86	BV-086	System #2 – pH Limit Alarm	Read Only
87	BV-087	System #2 – ORP High Alarm	Read Only
88	BV-088	System #2 – ORP Low Alarm	Read Only
89	BV-089	System #2 – ORP Limit Alarm	Read Only
90	BV-090	System #2 – S. Temp High Alarm	Read Only
91	BV-091	System #2 – S. Temp Low Alarm	Read Only
92	BV-092	System #2 – M. Temp High Alarm	Read Only

## object definitions

134	BV-134	System #2 – Notepad 9 Time Alarm	Read Only
135	BV-135	System #2 – Notepad 10 Time Alarm	Read Only
136	BV-136	System #2 – pH 2 Alarm	Read Only
137	BV-137	System #2 – ORP 2 Alarm	Read Only
138	BV-138	System #3 – Conductivity Alarm	Read Only
139	BV-139	System #3 – pH Alarm	Read Only
140	BV-140	System #3 – ORP Alarm	Read Only
141	BV-141	System #3 – S. Temp Alarm	Read Only
142	BV-142	System #3 – M. Temp Alarm	Read Only
143	BV-143	System #3 – D. Temp Alarm	Read Only
144	BV-144	System #3 – Timer 1 Alarm	Read Only
145	BV-145	System #3 – Timer 2 Alarm	Read Only
146	BV-146	System #3 – Timer 3 Alarm	Read Only
147	BV-147	System #3 – Timer 4 Alarm	Read Only
148	BV-148	System #3 – Timer 5 Alarm	Read Only
149	BV-149	System #3 – All Alarms	Read Only
150	BV-150	System #3 – Conductivity High Alarm	Read Only
151	BV-151	System #3 – Conductivity Low Alarm	Read Only
152	BV-152	System #3 – Conductivity Limit Alarm	Read Only
153	BV-153	System #3 – pH High Alarm	Read Only
154	BV-154	System #3 – pH Low Alarm	Read Only
155	BV-155	System #3 – pH Limit Alarm	Read Only
156	BV-156	System #3 – ORP High Alarm	Read Only
157	BV-157	System #3 – ORP Low Alarm	Read Only
158	BV-158	System #3 – ORP Limit Alarm	Read Only
159	BV-159	System #3 – S. Temp High Alarm	Read Only
160	BV-160	System #3 – S. Temp Low Alarm	Read Only
161	BV-161	System #3 – M. Temp High Alarm	Read Only
162	BV-162	System #3 – M. Temp Low Alarm	Read Only
163	BV-163	System #3 – D. Temp High Alarm	Read Only
164	BV-164	System #3 – D. Temp Low Alarm	Read Only
165	BV-165	System #3 – No Flow Alarm	Read Only
166	BV-166	System #3 – Digital Input 1 Alarm	Read Only
167	BV-167	System #3 – Digital Input 2 Alarm	Read Only
168	BV-168	System #3 – Digital Input 3 Alarm	Read Only
169	BV-169	System #3 – Digital Input 4 Alarm	Read Only
170	BV-170	System #3 – Digital Input 5 Alarm	Read Only
171	BV-171	System #3 – M. Conductivity Alarm	Read Only
172	BV-172	System #3 – M. Conductivity High Alarm	Read Only
173	BV-173	System #3 – M. Conductivity Low Alarm	Read Only
174	BV-174	System #3 – M. Conductivity Limit Alarm	Read Only

## object definitions

175	BV-175	System #3 – Notepad 1 High Alarm	Read Only
176	BV-176	System #3 – Notepad 2 High Alarm	Read Only
177	BV-177	System #3 – Notepad 3 High Alarm	Read Only
178	BV-178	System #3 – Notepad 4 High Alarm	Read Only
179	BV-179	System #3 – Notepad 5 High Alarm	Read Only
180	BV-180	System #3 – Notepad 6 High Alarm	Read Only
181	BV-181	System #3 – Notepad 7 High Alarm	Read Only
182	BV-182	System #3 – Notepad 8 High Alarm	Read Only
183	BV-183	System #3 – Notepad 9 High Alarm	Read Only
184	BV-184	System #3 – Notepad 10 High Alarm	Read Only
185	BV-185	System #3 – Notepad 1 Low Alarm	Read Only
186	BV-186	System #3 – Notepad 2 Low Alarm	Read Only
187	BV-187	System #3 – Notepad 3 Low Alarm	Read Only
188	BV-188	System #3 – Notepad 4 Low Alarm	Read Only
189	BV-189	System #3 – Notepad 5 Low Alarm	Read Only
190	BV-190	System #3 – Notepad 6 Low Alarm	Read Only
191	BV-191	System #3 – Notepad 7 Low Alarm	Read Only
192	BV-192	System #3 – Notepad 8 Low Alarm	Read Only
193	BV-193	System #3 – Notepad 9 Low Alarm	Read Only
194	BV-194	System #3 – Notepad 10 Low Alarm	Read Only
195	BV-195	System #3 – Notepad 1 Time Alarm	Read Only
196	BV-196	System #3 – Notepad 2 Time Alarm	Read Only
197	BV-197	System #3 – Notepad 3 Time Alarm	Read Only
198	BV-198	System #3 – Notepad 4 Time Alarm	Read Only
199	BV-199	System #3 – Notepad 5 Time Alarm	Read Only
200	BV-200	System #3 – Notepad 6 Time Alarm	Read Only
201	BV-201	System #3 – Notepad 7 Time Alarm	Read Only
202	BV-202	System #3 – Notepad 8 Time Alarm	Read Only
203	BV-203	System #3 – Notepad 9 Time Alarm	Read Only
204	BV-204	System #3 – Notepad 10 Time Alarm	Read Only
205	BV-205	System #3 – pH 2 Alarm	Read Only
206	BV-206	System #3 – ORP 2 Alarm	Read Only
207	BV-207	System #4 – Conductivity Alarm	Read Only
208	BV-208	System #4 – pH Alarm	Read Only
209	BV-209	System #4 – ORP Alarm	Read Only
210	BV-210	System #4 – S. Temp Alarm	Read Only
211	BV-211	System #4 – M. Temp Alarm	Read Only
212	BV-212	System #4 – D. Temp Alarm	Read Only
213	BV-213	System #4 – Timer 1 Alarm	Read Only
214	BV-214	System #4 – Timer 2 Alarm	Read Only
215	BV-215	System #4 – Timer 3 Alarm	Read Only

## object definitions

216	BV-216	System #4 – Timer 4 Alarm	Read Only
217	BV-217	System #4 – Timer 5 Alarm	Read Only
218	BV-218	System #4 – All Alarms	Read Only
219	BV-219	System #4 – Conductivity High Alarm	Read Only
220	BV-220	System #4 – Conductivity Low Alarm	Read Only
221	BV-221	System #4 – Conductivity Limit Alarm	Read Only
222	BV-222	System #4 – pH High Alarm	Read Only
223	BV-223	System #4 – pH Low Alarm	Read Only
224	BV-224	System #4 – pH Limit Alarm	Read Only
225	BV-225	System #4 – ORP High Alarm	Read Only
226	BV-226	System #4 – ORP Low Alarm	Read Only
227	BV-227	System #4 – ORP Limit Alarm	Read Only
228	BV-228	System #4 – S. Temp High Alarm	Read Only
229	BV-229	System #4 – S. Temp Low Alarm	Read Only
230	BV-230	System #4 – M. Temp High Alarm	Read Only
231	BV-231	System #4 – M. Temp Low Alarm	Read Only
232	BV-232	System #4 – D. Temp High Alarm	Read Only
233	BV-233	System #4 – D. Temp Low Alarm	Read Only
234	BV-234	System #4 – No Flow Alarm	Read Only
235	BV-235	System #4 – Digital Input 1 Alarm	Read Only
236	BV-236	System #4 – Digital Input 2 Alarm	Read Only
237	BV-237	System #4 – Digital Input 3 Alarm	Read Only
238	BV-238	System #4 – Digital Input 4 Alarm	Read Only
239	BV-239	System #4 – Digital Input 5 Alarm	Read Only
240	BV-240	System #4 – M. Conductivity Alarm	Read Only
241	BV-241	System #4 – M. Conductivity High Alarm	Read Only
242	BV-242	System #4 – M. Conductivity Low Alarm	Read Only
243	BV-243	System #4 – M. Conductivity Limit Alarm	Read Only
244	BV-244	System #4 – Notepad 1 High Alarm	Read Only
245	BV-245	System #4 – Notepad 2 High Alarm	Read Only
246	BV-246	System #4 – Notepad 3 High Alarm	Read Only
247	BV-247	System #4 – Notepad 4 High Alarm	Read Only
248	BV-248	System #4 – Notepad 5 High Alarm	Read Only
249	BV-249	System #4 – Notepad 6 High Alarm	Read Only
250	BV-250	System #4 – Notepad 7 High Alarm	Read Only
251	BV-251	System #4 – Notepad 8 High Alarm	Read Only
252	BV-252	System #4 – Notepad 9 High Alarm	Read Only
253	BV-253	System #4 – Notepad 10 High Alarm	Read Only
254	BV-254	System #4 – Notepad 1 Low Alarm	Read Only
255	BV-255	System #4 – Notepad 2 Low Alarm	Read Only
256	BV-256	System #4 – Notepad 3 Low Alarm	Read Only

## object definitions

257	BV-257	System #4 – Notepad 4 Low Alarm	Read Only
258	BV-258	System #4 – Notepad 5 Low Alarm	Read Only
259	BV-259	System #4 – Notepad 6 Low Alarm	Read Only
260	BV-260	System #4 – Notepad 7 Low Alarm	Read Only
261	BV-261	System #4 – Notepad 8 Low Alarm	Read Only
262	BV-262	System #4 – Notepad 9 Low Alarm	Read Only
263	BV-263	System #4 – Notepad 10 Low Alarm	Read Only
264	BV-264	System #4 – Notepad 1 Time Alarm	Read Only
265	BV-265	System #4 – Notepad 2 Time Alarm	Read Only
266	BV-266	System #4 – Notepad 3 Time Alarm	Read Only
267	BV-267	System #4 – Notepad 4 Time Alarm	Read Only
268	BV-268	System #4 – Notepad 5 Time Alarm	Read Only
269	BV-269	System #4 – Notepad 6 Time Alarm	Read Only
270	BV-270	System #4 – Notepad 7 Time Alarm	Read Only
271	BV-271	System #4 – Notepad 8 Time Alarm	Read Only
272	BV-272	System #4 – Notepad 9 Time Alarm	Read Only
273	BV-273	System #4 – Notepad 10 Time Alarm	Read Only
274	BV-274	System #4 – pH 2 Alarm	Read Only
275	BV-275	System #4 – ORP 2 Alarm	Read Only
276	BV-276	ma Input 1 Alarm	Read Only
277	BV-277	ma Input 1 High Alarm	Read Only
278	BV-278	ma Input 1 Low Alarm	Read Only
279	BV-279	ma Input 2 Alarm	Read Only
280	BV-280	ma Input 2 High Alarm	Read Only
281	BV-281	ma Input 2 Low Alarm	Read Only
282	BV-282	ma Input 3 Alarm	Read Only
283	BV-283	ma Input 3 High Alarm	Read Only
284	BV-284	ma Input 3 Low Alarm	Read Only
285	BV-285	ma Input 4 Alarm	Read Only
286	BV-286	ma Input 4 High Alarm	Read Only
287	BV-287	ma Input 4 Low Alarm	Read Only
288	BV-288	ma Input 5 Alarm	Read Only
289	BV-289	ma Input 5 High Alarm	Read Only
290	BV-290	ma Input 5 Low Alarm	Read Only
291	BV-291	ma Input 6 Alarm	Read Only
292	BV-292	ma Input 6 High Alarm	Read Only
293	BV-293	ma Input 6 Low Alarm	Read Only
294	BV-294	ma Input 7 Alarm	Read Only
295	BV-295	ma Input 7 High Alarm	Read Only
296	BV-296	ma Input 7 Low Alarm	Read Only
297	BV-297	ma Input 8 Alarm	Read Only
298	BV-298	ma Input 8 High Alarm	Read Only
299	BV-299	ma Input 8 Low Alarm	Read Only

## object definitions

**Analog Input Object Instance Summary Table 1-4**

Instance ID	Object Name	Purpose	Present Value – Access
0	AI-000	System #1 – Conductivity	Read Only
1	AI-001	System #2 – Conductivity	Read Only
2	AI-002	System #3 – Conductivity	Read Only
3	AI-003	System #4 – Conductivity	Read Only
4	AI-004	System #1 – M. Conductivity	Read Only
5	AI-005	System #2 – M. Conductivity	Read Only
6	AI-006	System #3 – M. Conductivity	Read Only
7	AI-007	System #4 – M. Conductivity	Read Only
8	AI-008	System #1 – pH	Read Only
9	AI-009	System #2 – pH	Read Only
10	AI-010	System #3 – pH	Read Only
11	AI-011	System #4 – pH	Read Only
12	AI-012	System #1 – ORP	Read Only
13	AI-013	System #2 – ORP	Read Only
14	AI-014	System #3 – ORP	Read Only
15	AI-015	System #4 – ORP	Read Only
16	AI-016	System #1 – S. Temp	Read Only
17	AI-017	System #2 – S. Temp	Read Only
18	AI-018	System #3 – S. Temp	Read Only
19	AI-019	System #4 – S. Temp	Read Only
20	AI-020	System #1 – M. Temp	Read Only
21	AI-021	System #2 – M. Temp	Read Only
22	AI-022	System #3 – M. Temp	Read Only
23	AI-023	System #4 – M. Temp	Read Only
24	AI-024	Sys #1 – Water Meter #1 - Total Value	Read Only
25	AI-025	Sys #2 – Water Meter #1 - Total Value	Read Only
26	AI-026	Sys #3 – Water Meter #1 - Total Value	Read Only
27	AI-027	Sys #4 – Water Meter #1 - Total Value	Read Only
28	AI-028	Sys #1 – Water Meter #2 - Total Value	Read Only
29	AI-029	Sys #2 – Water Meter #2 - Total Value	Read Only
30	AI-030	Sys #3 – Water Meter #2 - Total Value	Read Only
31	AI-031	Sys #4 – Water Meter #2 - Total Value	Read Only
32	AI-032	System #1 – M.Cycles	Read Only
33	AI-033	System #2 – M.Cycles	Read Only
34	AI-034	System #3 – M.Cycles	Read Only
35	AI-035	System #4 – M.Cycles	Read Only
36	AI-036	4-20 mA / 0-5V Input #1 - Value	Read Only
37	AI-037	4-20 mA / 0-5V Input #2 - Value	Read Only

## object definitions

38	AI-038	4-20 mA / 0-5V Input #3 - Value	Read Only
39	AI-039	4-20 mA / 0-5V Input #4 - Value	Read Only
40	AI-040	4-20 mA / 0-5V Input #5 - Value	Read Only
41	AI-041	4-20 mA / 0-5V Input #6 - Value	Read Only
42	AI-042	4-20 mA / 0-5V Input #7 - Value	Read Only
43	AI-043	4-20 mA / 0-5V Input #8 - Value	Read Only
44	AI-044	Flow Meter #1 – Total Value	Read Only
45	AI-045	Flow Meter #2 – Total Value	Read Only
46	AI-046	Flow Meter #3 – Total Value	Read Only
47	AI-047	Flow Meter #4 – Total Value	Read Only
48	AI-048	Flow Meter #5 – Total Value	Read Only
49	AI-049	Flow Meter #6 – Total Value	Read Only
50	AI-050	Flow Meter #7 – Total Value	Read Only
51	AI-051	Flow Meter #8 – Total Value	Read Only
52	AI-052	Flow Meter #9 – Total Value	Read Only
53	AI-053	Flow Meter #10 – Total Value	Read Only
54	AI-054	Flow Meter #1 – Flow Rate (per MIN)	Read Only
55	AI-055	Flow Meter #2 – Flow Rate (per MIN)	Read Only
56	AI-056	Flow Meter #3 – Flow Rate (per MIN)	Read Only
57	AI-057	Flow Meter #4 – Flow Rate (per MIN)	Read Only
58	AI-058	Flow Meter #5 – Flow Rate (per MIN)	Read Only
59	AI-059	Flow Meter #6 – Flow Rate (per MIN)	Read Only
60	AI-060	Flow Meter #7 – Flow Rate (per MIN)	Read Only
61	AI-061	Flow Meter #8 – Flow Rate (per MIN)	Read Only
62	AI-062	Flow Meter #9 – Flow Rate (per MIN)	Read Only
63	AI-063	Flow Meter #10 – Flow Rate (per MIN)	Read Only

**Analog Value Object Instance Summary Table 1-5**

Instance ID	Object Name	Purpose	Present Value – Access
0	AV-000	System #1 – Conductivity Setpoint #1	Read Only
1	AV-001	System #2 – Conductivity Setpoint #1	Read Only
2	AV-002	System #3 – Conductivity Setpoint #1	Read Only
3	AV-003	System #4 – Conductivity Setpoint #1	Read Only
4	AV-004	System #1 – Conductivity Setpoint #2	Read Only
5	AV-005	System #2 – Conductivity Setpoint #2	Read Only
6	AV-006	System #3 – Conductivity Setpoint #2	Read Only
7	AV-007	System #4 – Conductivity Setpoint #2	Read Only
8	AV-008	System #1 – Conductivity High Alarm	Read Only
9	AV-009	System #2 – Conductivity High Alarm	Read Only

## object definitions

10	AV-010	System #3 – Conductivity High Alarm	Read Only
11	AV-011	System #4 – Conductivity High Alarm	Read Only
12	AV-012	System #1 – Conductivity Low Alarm	Read Only
13	AV-013	System #2 – Conductivity Low Alarm	Read Only
14	AV-014	System #3 – Conductivity Low Alarm	Read Only
15	AV-015	System #4 – Conductivity Low Alarm	Read Only
16	AV-016	System #1 – M. Conductivity Setpoint	Read Only
17	AV-017	System #2 – M. Conductivity Setpoint	Read Only
18	AV-018	System #3 – M. Conductivity Setpoint	Read Only
19	AV-019	System #4 – M. Conductivity Setpoint	Read Only
20	AV-020	System #1 – M. Conductivity High Alarm	Read Only
21	AV-021	System #2 – M. Conductivity High Alarm	Read Only
22	AV-022	System #3 – M. Conductivity High Alarm	Read Only
23	AV-023	System #4 – M. Conductivity High Alarm	Read Only
24	AV-024	System #1 – M. Conductivity Low Alarm	Read Only
25	AV-025	System #2 – M. Conductivity Low Alarm	Read Only
26	AV-026	System #3 – M. Conductivity Low Alarm	Read Only
27	AV-027	System #4 – M. Conductivity Low Alarm	Read Only
28	AV-028	System #1 – pH Setpoint #1	Read Only
29	AV-029	System #2 – pH Setpoint #1	Read Only
30	AV-030	System #3 – pH Setpoint #1	Read Only
31	AV-031	System #4 – pH Setpoint #1	Read Only
32	AV-032	System #1 – pH Setpoint #2	Read Only
33	AV-033	System #2 – pH Setpoint #2	Read Only
34	AV-034	System #3 – pH Setpoint #2	Read Only
35	AV-035	System #4 – pH Setpoint #2	Read Only
36	AV-036	System #1 – pH High Alarm	Read Only
37	AV-037	System #2 – pH High Alarm	Read Only
38	AV-038	System #3 – pH High Alarm	Read Only
39	AV-039	System #4 – pH High Alarm	Read Only
40	AV-040	System #1 – pH Low Alarm	Read Only
41	AV-041	System #2 – pH Low Alarm	Read Only
42	AV-042	System #3 – pH Low Alarm	Read Only
43	AV-043	System #4 – pH Low Alarm	Read Only
44	AV-044	System #1 – ORP Setpoint #1	Read Only
45	AV-045	System #2 – ORP Setpoint #1	Read Only
46	AV-046	System #3 – ORP Setpoint #1	Read Only
47	AV-047	System #4 – ORP Setpoint #1	Read Only
48	AV-048	System #1 – ORP Setpoint #2	Read Only
49	AV-049	System #2 – ORP Setpoint #2	Read Only
50	AV-050	System #3 – ORP Setpoint #2	Read Only



## object definitions

51	AV-051	System #4 – ORP Setpoint #2	Read Only
52	AV-052	System #1 – ORP High Alarm	Read Only
53	AV-053	System #2 – ORP High Alarm	Read Only
54	AV-054	System #3 – ORP High Alarm	Read Only
55	AV-055	System #4 – ORP High Alarm	Read Only
56	AV-056	System #1 – ORP Low Alarm	Read Only
57	AV-057	System #2 – ORP Low Alarm	Read Only
58	AV-058	System #3 – ORP Low Alarm	Read Only
59	AV-059	System #4 – ORP Low Alarm	Read Only
60	AV-060	System #1 – S. Temp Setpoint	Read Only
61	AV-061	System #2 – S. Temp Setpoint	Read Only
62	AV-062	System #3 – S. Temp Setpoint	Read Only
63	AV-063	System #4 – S. Temp Setpoint	Read Only
64	AV-064	System #1 – S. Temp High Alarm	Read Only
65	AV-065	System #2 – S. Temp High Alarm	Read Only
66	AV-066	System #3 – S. Temp High Alarm	Read Only
67	AV-067	System #4 – S. Temp High Alarm	Read Only
68	AV-068	System #1 – S. Temp Low Alarm	Read Only
69	AV-069	System #2 – S. Temp Low Alarm	Read Only
70	AV-070	System #3 – S. Temp Low Alarm	Read Only
71	AV-071	System #4 – S. Temp Low Alarm	Read Only
72	AV-072	System #1 – M. Temp Setpoint	Read Only
73	AV-073	System #2 – M. Temp Setpoint	Read Only
74	AV-074	System #3 – M. Temp Setpoint	Read Only
75	AV-075	System #4 – M. Temp Setpoint	Read Only
76	AV-076	System #1 – M. Temp High Alarm	Read Only
77	AV-077	System #2 – M. Temp High Alarm	Read Only
78	AV-078	System #3 – M. Temp High Alarm	Read Only
79	AV-079	System #4 – M. Temp High Alarm	Read Only
80	AV-080	System #1 – M. Temp Low Alarm	Read Only
81	AV-081	System #2 – M. Temp Low Alarm	Read Only
82	AV-082	System #3 – M. Temp Low Alarm	Read Only
83	AV-083	System #4 – M. Temp Low Alarm	Read Only
84	AV-084	System #1 – D. Temp Setpoint	Read Only
85	AV-085	System #2 – D. Temp Setpoint	Read Only
86	AV-086	System #3 – D. Temp Setpoint	Read Only
87	AV-087	System #4 – D. Temp Setpoint	Read Only
88	AV-088	System #1 – D. Temp High Alarm	Read Only
89	AV-089	System #2 – D. Temp High Alarm	Read Only
90	AV-090	System #3 – D. Temp High Alarm	Read Only
91	AV-091	System #4 – D. Temp High Alarm	Read Only

## object definitions

92	AV-092	System #1 – D. Temp Low Alarm	Read Only
93	AV-093	System #2 – D. Temp Low Alarm	Read Only
94	AV-094	System #3 – D. Temp Low Alarm	Read Only
95	AV-095	System #4 – D. Temp Low Alarm	Read Only
96	AV-096	System #1 – Flow Switch Conf.	Read Only
97	AV-097	System #2 – Flow Switch Conf.	Read Only
98	AV-098	System #3 – Flow Switch Conf.	Read Only
99	AV-099	System #4 – Flow Switch Conf.	Read Only
100	AV-100	mA 1 - Output Value	Read Only
101	AV-101	mA 2 - Output Value	Read Only
102	AV-102	mA 3 - Output Value	Read Only
103	AV-103	mA 4 - Output Value	Read Only
104	AV-104	mA 5 - Output Value	Read Only
105	AV-105	mA 6 - Output Value	Read Only

**Multi-State Value Object Instance Summary Table 1-6**

Instance ID	Object Name	Purpose	Present Value – Access
0	MSV-000	Relay 1 – State	Read Only
1	MSV-001	Relay 2 – State	Read Only
2	MSV-002	Relay 3 – State	Read Only
3	MSV-003	Relay 4 – State	Read Only
4	MSV-004	Relay 5 – State	Read Only
5	MSV-005	Relay 6 – State	Read Only
6	MSV-006	Relay 7 – State	Read Only
7	MSV-007	Relay 8 – State	Read Only
8	MSV-008	Relay 9 – State	Read Only
9	MSV-009	Relay 10 – State	Read Only
10	MSV-010	Relay 11 – State	Read Only
11	MSV-011	Relay 12 – State	Read Only
12	MSV-012	Relay 13 – State	Read Only
13	MSV-013	Relay 14 – State	Read Only
14	MSV-014	Relay 15 – State	Read Only
15	MSV-015	Relay 16 – State	Read Only
16	MSV-016	Relay 17 – State	Read Only
17	MSV-017	Relay 18 – State	Read Only
18	MSV-018	Relay 19 – State	Read Only
19	MSV-019	Relay 20 – State	Read Only



# MarleyGard CD controller BACnet

USER MANUAL

---

**SPX COOLING TECHNOLOGIES, INC.**

7401 WEST 129 STREET  
OVERLAND PARK, KS 66213 USA  
913 664 7400 | [spxcooling@spx.com](mailto:spxcooling@spx.com)  
[spxcooling.com](http://spxcooling.com)

Z1069147 | ISSUED 4/2018

© 2018 SPX COOLING TECHNOLOGIES, INC | ALL RIGHTS RESERVED

In the interest of technological progress, all products are subject to design and/or material change without notice.

