

AV steel cooling tower

MARLEY®





The AV has 114 factory assembled tower models with 117-390 nominal tons per cell.

The Marley AV cooling tower is designed to minimize your costs and maximize your cooling performance through quick, easy installation and energy-efficient operation. Its single flow, induced draft crossflow design offers you pump and fan energy savings in a small footprint installation. The AV is an excellent replacement for forced draft counterflow cooling tower installations.

Every AV cooling tower benefits from all the knowledge and experience Marley has compiled from manufacturing cooling products for commercial and industrial use since 1922.



Key Benefits

IDEAL REPLACEMENT

Designed to easily replace forced draft or induced draft counterflow towers or other space sensitive installations.

LOW ENERGY COSTS

Highly efficient propeller fans consume half the energy of blowers. And, gravity water distribution provides further savings thru lower total pump head.

EASY ACCESS

Large, 762mm x 1067mm access doors on both endwalls and "stand-up" plenum area help make the AV easy to service with generous access to the basin and mechanical equipment. No "paint can lid" access hatches.

LOW PIPING COSTS

Single inlet connection for easy and fast installation.

LONG LIFE

Rugged Z725 galvanized steel frame, quality factory assembly. (Optionally available in 301L stainless steel.)

ALL SEASON RELIABILITY

Integral louvers eliminate splash-out so towers operate virtually ice-free in the winter.

REAL WORLD DESIGN

Designed for severe wind, seismic, shipping, operating and live loads.

TOUGH MX HIGH-PERFORMANCE FILM FILL

Highly efficient cellular drift eliminators and honeycomb air inlet louvers integrally molded within the fill sheets.

ALUMINUM-ALLOY AXIAL FAN

Adjustable-pitch fan blades permit maximum utilization of rated horsepower—allows field adjustment to optimize tower performance.

RUGGED FAN MOTOR

TEFC 1.15 service factor, severe duty, cast iron motor designed to Marley specifications for cooling tower duty. Specially insulated for extra protection from moisture.

FIVE-YEAR MECHANICAL WARRANTY

Five-year mechanical equipment warranty.

Features

AV AIR MOVEMENT SYSTEM

- Streamlined eased inlet fan cylinder assures full area, low turbulence airflow through the cylinder.
- Heavy duty aluminum alloy fan—adjustable pitch blades.
- 5.5 kW and larger fan motors are driven by a high quality, solid backed, multi-grooved neoprene and polyester v-belt thru a corrosion resistant aluminum alloy fan sheave.
- Heavy duty, self-aligning, grease lubricated roller bearings selected with an L₁₀ design life of 50,000 to 100,000 hours support the fan and shaft.
- TEFC fan motor, 1.15 service factor, variable torque design, specially insulated for cooling tower duty.
- The AV air movement system is guaranteed against failure for a period of five full years from date of shipment. Includes fan, fan shaft and mechanical equipment support.

AV WATER DISTRIBUTION SYSTEM

- Gravity flow distribution system. Easy, nonrestrictive maintenance. Basin covers are standard.
- Marley Spiral Target polypropylene nozzles for consistent, predictable water distribution.
- Marley MX thermoformed PVC film fill is suspended from the upper tower structure by heavy galvanized steel support members providing clearance between fill and sloping self-cleaning collection basin floor for easy basin cleaning. Integral eliminators and louvers keep circulating water confined to fill over a wide range of air flow rates.

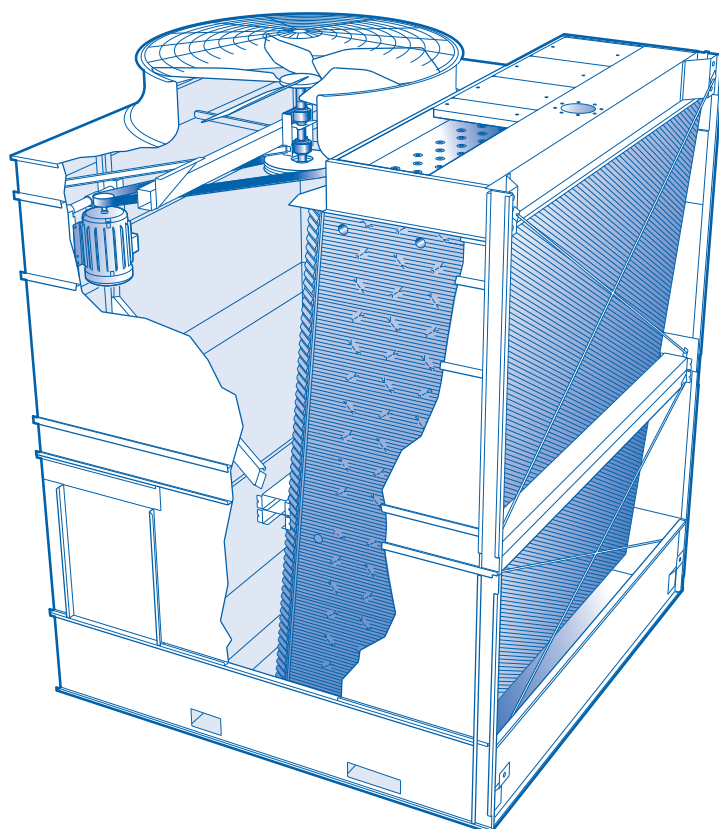

AV STRUCTURE

- Crossflow configuration — easier and safer to inspect, service and maintain.
- Z725 heavy galvanized steel. Also available in 300 series stainless steel.
- Factory-assembled modules, including fan cylinders — makes final field installation hassle-free.
- Large Access Doors—the generous plenum region in the AV tower is nonconfining, permitting quick visual inspection of cold water basin, internal structure, drift eliminators and mechanical equipment.

Note: For economical transportation, AV towers are also available unassembled and crated for export.

For Safety Reasons—always shut down and lock out the fan motor before entering the plenum.



Optional Equipment and Accessories

Enhance your AV tower installation with options and accessories that will improve the operation, longevity, maintenance, and accessibility of your cooling tower.

STAINLESS STEEL DISTRIBUTION BASIN

Corrosion is usually most aggressive in the hot water distribution basins, stainless steel provides assurance of long, trouble-free service life.

MARLEY CONTROL SYSTEM PACKAGE

Factory-wired, factory-installed, factory-tested control center in an IEC IP14 enclosure mounted on tower casing near access door. Complete with thermostat controller for single or two-speed motors to maintain chosen cold water temperature.

QUIET FAN

Provides lower sound levels for sound sensitive areas while maintaining CTI Certification and FM Approval. All sound data has been tested in accordance with ATC 128 to ensure accuracy.

ULTRA QUIET FAN

Wide chord acoustic geometry for areas that require a significant reduction in sound while maintaining CTI Certification and FM Approval. All sound data has been tested in accordance with ATC 128 to ensure accuracy.

EXTERNAL SERVICE PLATFORM

Provides easy access to distribution system without increasing installed height of tower. Platform with OSHA guardrails is Factory Mounted, eliminating installation labor cost and time. Field-installed ladder with optional safety cage for easy access.

STAINLESS STEEL COLLECTION BASIN

All collection basin parts in the wetted area—including structural members projecting in the basin, assembly and attaching hardware, and all basin options, are heavy-gauge 301L stainless steel.

AIR INLET SCREENS

Factory-installed, U-edged, galvanized wire mesh screens work in concert with the internal cellular louvers.

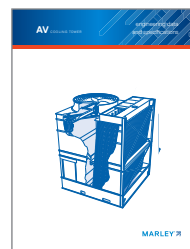

The AV Engineering Data and Specifications Manual AV-TS provides engineering schematics, data, and information necessary for initial tower layout and details the tower in the form of specification language, providing technical as well as common-sense information on the importance of your specifications. Available at spxcooling.com.

The Marley UPDATE™ web-based application software provides model selections perfectly tuned to your cooling water system. Functions include model selection, specifications, model optimization, performance curves, engineering data, and free cooling applications. Available to both registered customers and guests at spxcooling.com.

If we can help in any way, feel free to call. To find the Marley representative nearest you call 44 1905 750 270 or check the internet at spxcooling.com.

SPX COOLING TECHNOLOGIES MALAYSIA SDN BHD

UNIT 505, BLOCK B, PHILEO DAMANSARA 2
NO. 15 JALAN 16/11 OFF JALAN DAMANSARA
46350 PETALING JAYA, MALAYSIA
60 3 7947 7800 | th.my.enquiry@spx.com
spxcooling.com

sea_AV-13 | ISSUED 04/2016
COPYRIGHT © 2016 SPX CORPORATION
In the interest of technological progress, all products
are subject to design and/or material change without notice.

