

DTC series

EVAPORATIVE CONDENSER



DTC series

INDUCED-DRAFT EVAPORATIVE CONDENSER

Induced-Draft Models Designed for Performance and Value

Choose from a broad selection of DTC models in 260cm, 305cm and 366cm nominal widths and nominal lengths from 275cm to 1100cm to meet your specific refrigeration requirements.

Strong Galvanized Steel Construction

The high quality mechanical components and refrigeration coils are safely housed in heavy-duty galvanized steel to improve corrosion protection and help ensure low maintenance and longer life. Submerged areas are bolted or welded to minimize potential for leaks—tap screws are not used in submerged areas..

Stainless Steel Options

When environmental and design conditions dictate, heavy gauge stainless steel water collection basins and other structural components may be specified.

Easy to Install and Maintain

The DTC can reduce installation and maintenance time:

- Module connections require minimal fasteners
- Pre-assembled platform options have welded guardrails

Dual U-Bolt Fan Hub

The DTC fan hub is designed to reduce fan de-pitching and vibration potential for better performance.



Sound Reduction

Quiet operation is an important part of product specifications. Sound reduction options enable induced draft selections with sound levels up to 15+ dbA lower than similar steel forced draft condensers.

Value-Added Construction Details

MARLEY GEAREDUCER® DRIVE

Genuine Marley mechanical system offers low maintenance costs and reliable performance with 5-year warranty. Belt drive optional.

CLOG-RESISTANT SPRAY SYSTEM

Large orifice spray nozzles help prevent debris build-up and clogging.

TRIPLE-PASS AIR INLET LOUVERS

Removable louvers incorporate three changes in direction to control splash out and sunlight exposure to limit algae growth.

Marley Reliability

Heavy-duty construction, galvanized and stainless steel material options, high-performance design and our five-year mechanical warranty ensure consistent cooling over a wide range of closed-circuit cooling applications.

Broad Product Selection

Choose from DTC models in a wide range of sizes and layouts to meet your specific refrigeration requirements.

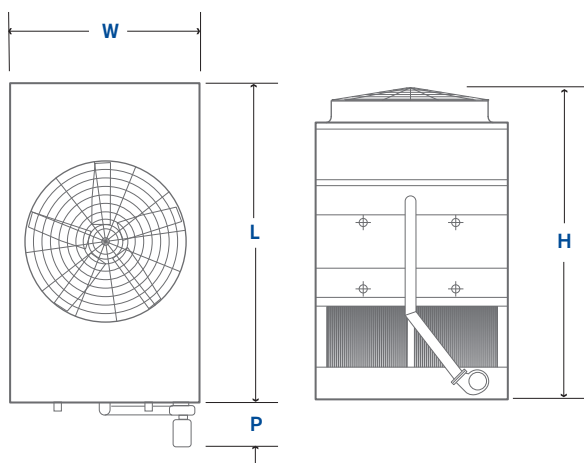
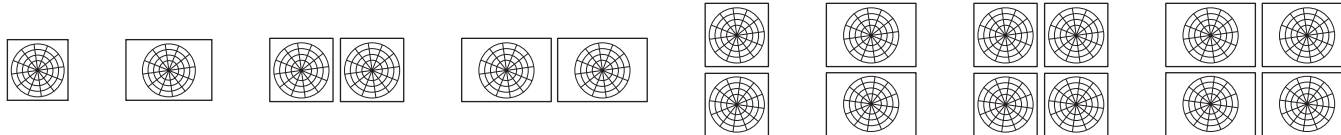

Models	L	W	P	H*
DTC8509	2743	2591	610	3835 – 4547
DTC8512	3658	2591	610	3962 – 4648
DTC1012	3683	3023	660	4648 – 5334
DTC1212	3683	3632	660	4648 – 5334
DTC1018	5537	3048	660	4928 – 5613
DTC1218	5537	3658	660	5029 – 5740

*Single cell heights shown, height increases for multiple cell models.



IS THE MARLEY DTC RIGHT FOR YOUR APPLICATION?



Find out at spxcooling.com/coolspec

SPX COOLING TECHNOLOGIES MALAYSIA SDN BHD

UNIT 505, BLOCK B, PHILEO DAMANSARA 2
NO. 15 JALAN 16/11 OFF JALAN DAMANSARA
46350 PETALING JAYA, MALAYSIA
60 3 7947 7800 | th.my.enquiry@spx.com

spxcooling.com

sea_DTC-24 | ISSUED 03/2024

©2024 SPX COOLING TECH, LLC | ALL RIGHTS RESERVED

In the interest of technological progress, all products
are subject to design and/or material change without notice.

SPX 
TECHNOLOGIES