

**/ MH** Fluid Cooler **/**

---

*User Manual sea\_05-116F*





---

# Contents

---

## Note

***This manual contains vital information for the proper installation and operation of your fluid cooler. Carefully read the manual before installation or operation of the fluid cooler and follow all instructions. Save this manual for future reference.***

Fluid Cooler Location.....	5
Fluid Cooler Shipment.....	6
Receiving Fluid Cooler.....	6
Hoisting Fluid Cooler.....	6
Fluid Cooler Installation.....	7
Motor Wiring.....	9
Mechanical Equipment.....	11
Fluid Cooler Start-Up.....	13
Fluid Cooler Operation.....	15
Wintertime Operation.....	18
Water Treatment.....	21
Fluid Cooler Cleaning.....	24
Blowdown.....	24
Belt Tensioning.....	26
Sheave Alignment.....	28
Fluid Cooler Maintenance.....	29
Seasonal Shutdown Instructions.....	32
Long-Term Storage Procedures.....	34
Troubleshooting.....	39
Additional Information.....	41

The following defined terms are used throughout this manual to bring attention to the presence of hazards of various risk levels, or to important information concerning the life of the product.

---

## Warning

***Indicates presence of a hazard which can cause severe personal injury, death or substantial property damage if ignored.***

---

## Caution

***Indicates presence of a hazard which will or can cause personal injury or property damage if ignored.***

---

## Note

***Indicates special instructions on installation, operation or maintenance which are important but not related to personal injury hazards.***

---

## Preparation

The Marley MH Fluid Cooler with CoolBoost™, purchased for this installation represents the current state of the art in crossflow, induced draft fluid cooler design. Thermally and operationally, it is the most efficient fluid cooler of its class.

These instructions—as well as those offered separately on motors, fans, Geareducer®, couplings, drive shafts, float valves, pumps, etc.—are intended to assure that the fluid cooler serves you properly for the maximum possible time. Since product warrantability may well depend upon your actions, please read these instructions thoroughly prior to operation.

If you have questions about the operation and/or maintenance of this product, and you don't find the answers in this manual, please contact your Marley sales representative. When writing for information, or when ordering parts, please mention product serial number shown on the nameplate located on the access door.

---

## Safety First

The location and orientation of the fluid cooler can affect the safety of those responsible for installing, operating or maintaining the fluid cooler. However, since SPX Cooling Technologies does not determine the location or orientation of the fluid cooler, we cannot be responsible for addressing those safety issues that are affected by the fluid cooler's location or orientation.

---

### Warning

***The following safety issues should be considered by those responsible for designing the tower installation.***

- ***access to and from the fan deck***
- ***access to and from maintenance access doors***
- ***the possible need for ladders (either portable or permanent) to gain access to the fan deck or maintenance access doors***
- ***the possible need for handrails around the fan deck***
- ***the possible need for external access platforms***
- ***potential access problems due to obstructions surrounding the tower***
- ***lockout of mechanical equipment***
- ***the possible need for safety cages around ladders***
- ***the need to avoid exposing maintenance personnel to the potentially unsafe environment inside the fluid cooler***

---

## Preparation

---

### Note

***It is not intended nor assumed that access to the fan deck on single-flow models—Models MHF702 thru MHF705—is needed or necessary.***

***Those are only some of the safety issues that may arise in the design process. SPX strongly recommends that you consult a safety engineer to be sure that all safety considerations have been addressed.***

Several options are available that may assist you in addressing some of these personnel safety concerns, including:

- Louver face distribution basin access platform with ladder and handrail.
- Louver face redistribution basin level access platform with ladder and handrail.
- A handrail system around the perimeter of the fan deck with either one or two ladders for access to the deck. Double-flow models MHF706 and MHF707 only.
- Extended fan deck that provides additional access around one end of the fan cylinder opposite the fan deck access ladder. Double-flow models MHF706 and MHF707 only.
- Ladder extensions—used where the base of the tower is elevated.
- Safety cages for ladders.
- External lube lines.
- Access door platform.
- Motor located outside the tower. Double-flow models MHF706 and MHF707 with Geareducer drive only.
- External motor access platform. Double-flow models MHF706 and MHF707 with Geareducer drive only.
- Plenum walkway. Double-flow models MHF706 and MHF707 only. Standard on all other models.
- Mechanical equipment access platform.

---

### Fluid Cooler Location

Space available around the fluid cooler should be as generous as possible to promote ease of maintenance—and to permit freedom of airflow into and through the fluid cooler. If you have questions about the adequacy of the available space and the intended configuration of the fluid cooler, please contact your Marley sales representative for guidance.

Prepare a stable, level support foundation for the fluid cooler, utilizing weight, wind load, and dimensional information appearing on appropriate Marley submittal drawings. Supports must be level to insure proper operation of the fluid cooler.



---

## Installation

---

### Warning

*The fluid cooler must be located at such distance and direction to avoid the possibility of contaminated fluid cooler discharge air being drawn into building fresh air intake ducts. The purchaser should obtain the services of a Licensed Professional Engineer or Registered Architect to certify that the location of the fluid cooler is in compliance with applicable air pollution, fire and clean air codes.*

---

### Fluid Cooler Shipment

Unless otherwise specified, the MH Fluid Cooler ships by truck (on flat bed trailers), which lets you receive, hoist, and install the tower in one continuous operation. Single-cell single-flow fluid coolers ship on one truck. Double-flow and multicell fluid coolers, depending on their size, may require more than one truck.

Responsibility for the condition of the fluid cooler upon its arrival belongs to the trucker—as does the coordination of multiple shipments, if required.

---

### Receiving Fluid Cooler

Prior to unloading the fluid cooler from the delivering carrier, inspect the shipment for evidence of damage in transit. If damage is apparent, note the freight bill accordingly. This will support your future recovery claim.

Find and remove the installation instruction drawings and bills of material located in a plastic bag in the water collection basin. This information should be kept for future reference and maintenance purposes.

---

### Hoisting Fluid Cooler

All MH Fluid Cooler models must use hoist clips and overhead lifting for handling assembled fluid cooler. **Forklifting from base of fluid cooler is not permitted.** The clips for the top modules are located at the fan deck level. The clips for the lower modules are located at the bottom of the modules at the water collection basin. A **Hoisting-Installation** label which has hoisting dimensional information is located on the side casing near the tower centerline. Remove tower from the carrier and hoist into place according to the instructions on the label.

---

### Caution

*MH Fluid Cooler upper and lower modules must be hoisted and set separately. Do not preassemble modules prior to hoisting.*

---

## Installation

---

### ⚠ Warning

**Hoisting clips are provided for ease of unloading and positioning the fluid cooler. For overhead lifts or where additional safety is required, safety slings should also be placed under the fluid cooler modules. Under no circumstances should you combine the top and bottom modules of modular models and attempt to hoist them at the same time by utilizing the hoisting clips alone!**

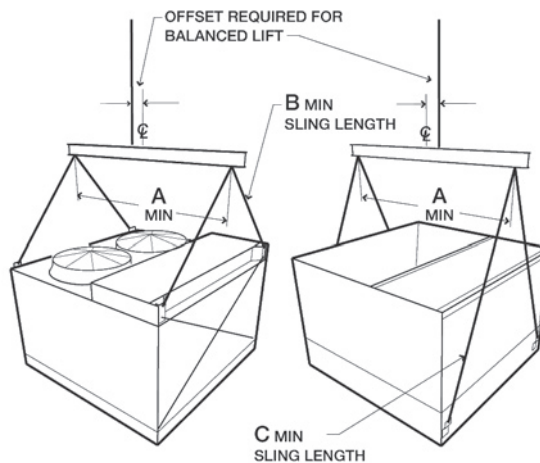

---

### Fluid Cooler Installation

---

#### Note

**These installation instructions are intended to help you prepare before your fluid cooler arrives. If discrepancies exist between these instructions and those shipped with the fluid cooler, the instructions shipped with the fluid cooler will govern.**

1. Prior to placement of the fluid cooler, confirm that the supporting platform is level, and that the anchor bolt holes are correctly located in accordance with Marley drawings. If your installation uses vibration isolators to dampen vibration, they must be mounted **below** the supporting steel. See support drawings for further information.
2. Place bottom module on your prepared supports, aligning anchor bolt holes with those in your supporting steel. Make sure that the orientation agrees with your intended piping arrangement. Attach fluid cooler to supporting steel with  $\frac{3}{4}$ " diameter bolts and flat washers (by others). See support drawing for location and quantity. Position flat washers between the bolt head and the fluid cooler basin flange.



---

## Installation

3. Before setting top module in place on bottom module, clean any debris from the underside of the top module fill, skid and beams and from the top of the bottom module and remove shipping cover from bottom of top module—replace fasteners at side of module to prevent leaks. Place top module on the top peripheral bearing surface (factory-installed gasket) of bottom module, aligning mating holes as it is set in place. Attach top module to bottom module with fasteners provided according to drawings shipped with your fluid cooler.
4. Connect the recirculation piping with rubber coupling shipped with the bottom module piping according to drawings shipped with you fluid cooler.
5. Attach makeup water supply piping to appropriately-sized float valve connection located in collection water basin side wall. Install the drain and overflow according to drawings shipped with your fluid cooler. If you wish to pipe overflow and drain water to a remote discharge point, make those connections at this time also.

---

### Note

***Fasteners and components provided by others that are to be attached to the tower must be compatible with the cooling tower materials—i.e. fasteners in a stainless steel cold water basin must be stainless steel.***

6. Attach process fluid supply and return piping to the coil. Field piping connection is an NPT male connection at the coil. A welded connection requires removing the threaded portion of the coil.

---

### Caution

***Except for the horizontal components of piping, do not support your pipe from the tower inlet connection—support it externally.***

Normally, one of the following two inlet arrangements is provided:

**Bevel and groove distribution connection:** This is a factory-installed, galvanized pipe nipple, extending horizontally from the side of the tower. It is both beveled for welding—and grooved for a mechanical coupling. If a weld connection is used, it is recommended that the weld area be protected against corrosion. Cold galvanizing is suggested, applied according to the manufacturer's instructions.

**Flanged distribution connection:** The coil is fitted with a flat-face flange connection that conforms to 125# ANSI B16.1 specifications. A full faced gasket and appropriately sized bolts (by others) must be used for proper distribution function.



---

## Installation

---

### Caution

***For welded connections protect adjacent areas from excessive heat and sparks or damage may occur.***

7. Wire motor(s) and recirculation pump(s) in accordance with wiring diagram.

---

### Warning

***For maintenance/safety purposes, SPX recommends a lockout type disconnect switch for all mechanical equipment. In addition to a disconnect switch, the motor should be wired to main power supply through short circuit protection, and a magnetic starter with overload protection.***

---

## Motor Wiring

Wire motor leads as shown on the motor nameplate matching the supply voltage. Do not deviate from the motor nameplate wiring.

Either of following symbols may be shown on the motor nameplate –  $\Delta$ ,  $\Delta \Delta$ , Y, or YY. These symbols represent how the motor is constructed on the inside and in no way have anything to do with a Delta or Wye electrical distribution system serving the motor.

### **When using a starter:**

- Set motor overload protection to 110% of motor nameplate amps. This setting allows the fan motor to operate during cooler weather. During cooler weather it is common for the motor to draw 6 to 10% higher than nameplate amps. High amps are common during tower commissioning when the tower is dry and the ambient air temperature is cool.

---

### Note

***Do not start the motor more than four to five times per hour. Short cycling the tower will cause fuses, breakers or O.L.s to operate and will decrease motor life.***

### **When using a two-speed starter:**

- Motor rotation must be the same at slow speed and high speed.
- Single winding motor requires a starter with a shorting contactor.
- Two-winding motor requires a starter with out a shorting contactor.
- All two-speed starters must have a 20 second time delay relay when switching from high speed to low speed.



---

## Installation

---

### Note

***Do not start the motor more than four to five times per hour (each low speed start and each high speed start count as one start).***

### **When using a VFD:**

---

### Note

***Before beginning, ensure that the motor is rated for “Inverter Duty” per IEC standards.***

- Set the VFD solid state overload protection to 119% of motor nameplate amps and set “maximum current parameter” in the VFD to motor nameplate amps. “Maximum current parameter” will reduce fan speed and limit amp draw to nameplate amps during cold weather operation. If furnished with a mechanical O.L. set this at 110% over motor nameplate amps.
- Motor rotation must be the same in both VFD mode and By-pass mode.
- If cable distance between the VFD and motor is greater than 30 m a DV/DT output filter is recommended to avoid damage to the motor. 30 m distance is based on our field experience, the VFD manufacture may state different distances and distance does vary depending on the VFD manufacture.
- Program the VFD for variable torque output. Flux vector and constant torque modes may damage the gearbox.
- Do not start and stop the motor using the safety switch at the motor. If the drive is being commanded to run and the load side is cycled ON and OFF with the safety switch this may damage the VFD.

---

### **Warning**

Using a VFD in cooling applications has advantages over traditional single or two speed motor control. A VFD can reduce the cost of electrical energy being used and provide better temperature control. In addition, it reduces the mechanical and electrical stress on the motor and mechanical equipment. Electrical savings can be large during periods of low ambient temperature when the cooling requirement can be satisfied at reduced speeds. To benefit from these advantages, it is important that the drive be installed correctly.

Marley supplies VFD and VFD controls specifically designed for our cooling products. If you have purchased a Marley VFD and/or controls package, please follow the instructions in the *User Manual* for that system. Most VFD problems can be avoided by purchasing the Marley drive system. If you are installing a VFD other than the Marley drive, please refer to that drives installation manual.

---

## Installation

---

**⚠ Warning**

***Improper use of a VFD may cause damage to equipment or personal injury. Failure to correctly install the VFD drive will automatically void all warranties associated with the motor and any equipment that is either electrically or mechanically (directly) attached to the VFD drive system. The length of this warranty avoidance will be contingent on properly installing the VFD system and repairing any damage that may have occurred during its operation. SPX Cooling Technologies does not assume responsibility for any technical support or damages for problems associate with non-Marley brand VFD systems.***

---

**⚠ Warning**

***Changing the operational fan speed from the factory settings could cause the fan to operate in an unstable region which may result in damage to the equipment and possible injury.***

---

### **Mechanical Equipment:**

---

**⚠ Warning**

***The fluid cooler is designed to operate at full speed and half speed. Warranty is void if the tower is operated at speeds which cause damaging vibrations to the tower and associated equipment. When utilizing a variable frequency drive, the tower must be tested across the full range of speeds and checked against CTI guidelines for excessive vibration. Speed ranges not meeting these guidelines must be locked out in the VFD.***

---

**⚠ Warning**

***Always shut off electrical power to the tower fan motor prior to performing any maintenance on the tower. Any electrical switches should be locked out and tagged out to prevent others from turning the power back on.***

1. If equipped, check oil level in accordance with the *Geareducer User Manual* for the Geareducer. (Although the Geareducer was filled to the proper level at the factory, tipping during shipment and hoisting may have caused some loss of oil.) If oil is required, fill Geareducer to the proper level with approved lubricant. (See *Geareducer User Manual* ) Check oil level at the Geareducer or dipstick (standpipe located on fan deck, if so equipped) to confirm that the proper level is indicated.
2. On double-flow models—MHF706 and MHF707—install fan cylinder and two-piece fan guard according to the installation drawing shipped with the fluid cooler.



---

## Installation

---

### Warning

***Improper installation of the fan cylinder and fan guard will destroy the structural integrity of the fan guard. Failure of the fan guard could allow operating or maintenance personnel to fall into the rotating fan.***

3. Spin the fan(s) manually to assure that all fan blades properly clear the inside of the fan cylinder. If equipped, observe the action of the coupling (or drive shaft couplings) to be sure that the motor and Geareducer are properly aligned. If necessary, correct the alignment in accordance with the included manual. For belt drive equipped models observe the action of the sheaves and belts to be sure that the motor is properly aligned with the fan sheave. See Belt Tensioning and Sheave Alignment on pages 26 thru 28.

---

### Note

***It is essential that the fan cylinder and fan guard be installed in accordance with the drawings shipped with the tower. Do not force the fan cylinder out of round.***

4. Momentarily bump (energize) the motor(s) and observe rotation of the fan(s). If rotation is backwards, shut off the fan and reverse two of the three primary leads supplying power to the motor.

---

### Caution

***If tower is equipped with a two-speed motor, check for proper rotation at both speeds. Check also to see that starter is equipped with a 20 second time delay which prevents direct switching from high speed to low speed. If the fan is intended to be reversed for deicing purposes, make sure that the starter is equipped with a 2 minute time delay between changes of direction. These delays will prevent abnormal stress from being applied to the mechanical equipment and the electrical circuit components.***

5. Run the motor and observe the operation of the mechanical equipment. Operation should be stable, and, if equipped, there should be no evidence of oil leakage from the Geareducer.
6. If equipped with belt drive check the torque on the fan and motor sheave after 10 - 60 hrs. of operation. See Bushing Fastener Torque Values on page 28.

---

### Note

***If the water supply system is not being operated—or if there is no heat load on the system—motor amps read at this time may indicate an apparent overload of as much as 10–20%. This is because of the increased density of unheated air flowing through the fan. Determination of an accurate motor load should await the application of the design heat load.***

---

## Operation

---

---

### Warning

#### Fluid Cooler Start-Up

***Among other sources, outbreaks of Legionnaires' Disease have reportedly been traced to cooling towers and fluid coolers. Maintenance and water treatment procedures that prevent amplification and dissemination of Legionella and other airborne bacteria should be formulated and implemented BEFORE systems are operated and continued regularly thereafter to avoid the risk of sickness or death.***

#### Water System:

1. New installations should be cleaned and treated with biocides by a water treatment expert before startup.
2. Remove any and all accumulated debris from fluid cooler. Pay particular attention to inside areas of collection water basin, distribution water basins, louvers and drift eliminators. Make sure that cold water suction screens are clear and properly installed.
3. Fill the water system to an approximate depth of 203 mm in the depressed area of the collection water basin. This is the recommended operating water level. Adjust the float valve so that it is 75% open at that level. Continue filling the system until the water reaches a level approximately 3 mm below the lip of the overflow.
4. Start your pump(s) and check for proper rotation as indicated by the arrow on the pump cover, observe system operation. A certain amount of "pump-down" of the basin water level will occur before water completes the circuit and begins to fall from the fill in the upper module. The amount of initial pump-down may be insufficient to cause the float valve to open. However, you can check its operation by pressing down on the operating lever to which the stem of the float valve is attached.



---

## Operation

Some trial and error adjustment of the float valve may be required to balance the makeup water with tower operation. Ideally, the float valve setting will be such that no water is wasted through the overflow at pump shutdown. However, the water level after pump start-up **must** be deep enough to assure positive pump suction.

5. Open the valve on the tower bleed line and adjust bleed to the recommended rate. See Water Treatment section on page 20.
6. Continue pump operation for about 15 minutes, after which it is recommended that the water system be drained, flushed and refilled.
7. While operating the recirculating water pump(s) and prior to operating the fluid cooler fan, execute one of the two alternative biocidal treatment programs described in the following:
  - Resume treatment with the biocide which had been used prior to shutdown. Utilize the services of the water treatment supplier. Maintain the maximum recommended biocide residual (for the specific biocide) for a sufficient period of time (residual and time will vary with the biocide) to bring the system under good biological control **or**
  - Treat the system with sodium hypochlorite to a level of 4 to 5 mg/L free chlorine residual at a pH of 7.0 to 7.6. The chlorine residual must be held at 4 to 5 mg/L for six hours, measurable with standard commercial water test kits.

If the fluid cooler has been in operation and then shut down for a duration of time and not drained, perform one of the two previous biocidal treatment programs directly to the fluid cooler storage vessel (collection basin, drain down tank, etc.) without circulating stagnant water over the cooling tower fill or operating the cooling tower fan.

After biocidal pretreatment has been successfully completed, cooling water may be circulated over the tower fill with the fan off.

When biocidal treatment has been maintained at a satisfactory level for at least six hours, the fan may be turned on and the system returned to service. Resume the standard water treatment program, including biocidal treatment.

---

# Operation

---

## Fluid Cooler Operation

### General:

The cold process fluid temperature obtained from an operating fluid cooler will vary with the following influences:

1. **Heat load:** With the fan in full operation, if the heat load increases, the cold process fluid temperature will rise. If the heat load reduces, the cold process fluid temperature will reduce.

$$\text{Range} - ^\circ\text{C} = \frac{\text{Heat Load (kW)}}{\text{Water Flow (m}^3\text{/hr)} \times 1.162}$$

Note that the number of degrees (“range”) through which the fluid cooler cools the process fluid is established by the system heat load and the amount of fluid being circulated, in accordance with the following formula—formula is only valid for 100% water as process fluid:

The fluid cooler establishes only the cold process fluid temperature attainable under any operating circumstance.

2. **Air wet-bulb temperature:** Cold process fluid temperature will also vary with the wet-bulb temperature of the air entering the louvered faces of the fluid cooler. Reduced wet-bulb temperatures will result in colder process fluid temperatures. However, the cold process fluid temperature will not vary to the same extent as the wet-bulb. For example, a 11°C reduction in wet-bulb may result in only a 8°C reduction in cold process fluid temperature.
3. **Fluid flow rate:** Increasing the process fluid flow rate (m<sup>3</sup>/hr) will cause a slight elevation in cold process fluid temperature, while reducing the fluid flow rate will cause the cold process fluid temperature to decrease slightly. However, at a given heat load (see formula above), process fluid flow reductions also cause an increase in the incoming hot process fluid temperature and thermal range.
4. **Air flow rate:** Reducing air flow through the fluid cooler causes the cold process fluid temperature to rise. This is the recommended method by which to control leaving process fluid temperature.

If your fluid cooler is equipped with a single-speed motor, the motor may be shut off when the process fluid temperature becomes too cold. This will cause the process fluid temperature to rise. When the fluid temperature then becomes too warm for your process, the motor can be restarted.

---

## Operation

### Fan cycling limits:

---

#### Note

**Considering the normal fan and motor sizes utilized on MH Fluid Coolers, anticipate that approximately 4 to 5 starts per hour are allowable.**

If your fluid cooler is equipped with a two-speed motor(s), you will enjoy greater opportunity for process temperature control. When the process fluid temperature becomes too cold, switching the fan to half-speed will cause the cold process fluid temperature to rise—stabilizing at a temperature a few degrees higher than before. With a further reduction in fluid temperature, the fan may be cycled alternately from half-speed to off.

---

#### Note

**Do not start the motor more than four to five times per hour (each low speed start and each high speed start count as one start).**

For greater insight on process fluid temperature control, please read **“Cooling Tower Energy and its Management”**, *Technical Report #H-001-A*, available at [spxcooling.com](http://spxcooling.com).

**Pump cycling limits:** Marley does *not* recommend the recirculation water pump(s) be cycled to control process fluid temperature. It is recommended that while process fluid is being circulated through the coil the fluid cooler recirculation water system always be in operation. Cycling the recirculation water pump(s) may lead to premature scaling of the coil surface.

**Dampers:** If equipped, the positive closure damper system is designed to help prevent heat loss from the coil due to air movement caused by convection or wind conditions when both the fan and pump are off.

Upon start-up of the fluid cooler fans, the damper actuator is energized and rotates the damper assembly blades open. The actuator should be wired into the control circuitry of the fan motor. Upon system shutdown the damper actuator is de-energized and the spring return actuator returns the damper blades to the closed position.

---

#### Note

**If the dampers are equipped with an automatic electric actuator, the actuator electric motor controller will include a 115-volt AC space heater in accordance with the SPX Cooling specification. The space heater is to be energized at all times whether actuator**



---

## Operation

***motor is operating or not. The purpose of the energized space heater is to prevent moisture inside the unit from corroding the internal components. Failure to wire and energize the space heater will void the warranty if the actuator fails due to internal corrosion.***

***Automatic Electric Actuator must be stored in a dry environment until installed. If a unit is going to sit idle prior to startup, the actuator must be removed from the damper and stored appropriately.***

### **Redundant Pump Operation:**

To ensure operation without fail, a redundant pump system may have been purchased for the fluid cooler. The system does not automatically switch on the backup pump if the primary pump fails. Manual valve adjustment is required on all models. If continual pump operation is essential, it would be prudent to include a circuit in the controls system notifying the operator of any pump failure so they may change valving as quickly as possible.

**MHF702 through MHF705:**The redundant pump system is comprised of an external skid with 2 pumps and necessary piping and valves to operate each pump. Should the primary pump fail, shut down power to both pumps. Manually throw the necessary valves on the pump skid and energize the secondary pump. This design allows the primary pump to be replaced while the secondary pump is in operation.

Both pumps are identical and either may be used as the primary. It is recommended that pumps and valves are occasionally cycled to ensure that both pump systems remain in suitable running condition.

**MHF706 and MHF707:**The redundant pump system is comprised of two pumps mounted inside the tower, with necessary piping and valves to operate each pump. Should the primary pump fail, shut down power to both pumps. Manually throw the necessary valves and energize the secondary pump. This design allows the secondary pump to run at full capacity until a time when it is acceptable to shut down both pumps and drain the basin of water. The primary pump can not be replaced while the basin contains water.

Both pumps are identical and either may be used as the primary. It is recommended that pumps and valves are occasionally cycled to ensure that both pump systems remain in suitable running condition.

---

# Operation

---

## Wintertime Operation

The Marley film-fill system used in the MH Fluid Cooler has air entrance louvers that are molded as an integral part of the fill. This feature makes these fluid coolers very forgiving of cold weather operation, even at the low temperature and reduced load conditions encountered in low temperature applications. Nevertheless, during operation in subfreezing weather the opportunity exists for ice to form in the colder regions of the fluid cooler.

---

### Note

***Slushy, transitory ice forms routinely in the colder regions of the fill of low temperature towers, and is visible through the tower louvers. Such ice normally has no adverse effect on fluid cooler operation, but its appearance should be a signal to the operator to undertake ice control procedures.***

***It is the operator's responsibility to prevent the formation of destructive (hard) ice on the fluid cooler fill. Certain guidelines should be followed:***

1. Do not allow the fluid cooler's leaving process fluid temperature to drop below 7°C. If such low temperature operation is necessary or beneficial to your process, establish the minimum allowable level as follows:

During the coldest days of the first winter of operation, observe whether any ice is forming on the louver face, particularly near the bottom part of the louver face. If hard ice is present on the louvers, you must increase the allowable cold water temperature.

---

### Caution

***If the minimum allowable cold process fluid temperature is established at or near minimum heat load, it should be safe for all operating conditions.***

Having established the minimum allowable cold water temperature, maintaining that temperature can be accomplished by fan manipulation, as outlined in **Item 4** under **Fluid Cooler Operation**.

2. As cold air enters the louvers, it causes the water flowing over the fill to be drawn inward toward the center of the tower. Thus, under fan operation, the louvers and lower periphery of the tower structure remain partly dry, seeing only random splashing from within the tower—plus normal

---

## Operation

atmospheric moisture from the entering air. Such lightly wetted areas are most subject to freezing.

Therefore, if excessive ice forms on the louvers, stop the fan for a few minutes. With the fan off, the water flow will increase in the vicinity of the louvers and reduce the ice buildup.

3. Under extended extreme cold conditions, it may be necessary to operate the fan in reverse. This forces warm air out through the louvers, melting any accumulated ice—adequate heat load must be available. Reversal may be at either full or half speed; however, reversal at half speed is recommended. Reverse operation of the fan should be used sparingly and should only be used to control ice, **not** to prevent it. Reverse fan operation should not need to exceed 1 or 2 minutes. Monitoring is required to determine the time required to melt accumulated ice.

---

 **Warning**

***Reverse operation of fans for prolonged periods during subfreezing weather can cause severe damage to fans and fan cylinders. Ice can accumulate inside fan cylinders at fan blade plane of rotation and fan blade tips will eventually strike this ring of ice, damaging the fan blades or cylinder. Ice can also accumulate on fan blades and be thrown off, damaging fan cylinder or blades. Allow a minimum of 10 minute delay between reverse operation and forward operation during subfreezing weather to permit ice to dissipate from fan blades and fan cylinders. See Fan Drive Caution note on page 12 for fan speed change and reversing precautions.***

### **Intermittent Wintertime Operation:**

If periods of shutdown (nights, weekends, etc.) occur during freezing weather, measures must be taken to prevent the water in the cold water basin—and all exposed pipework—from freezing. Several methods are used to combat this, including automatic basin heater systems and pump freeze protection systems available from Marley.

---

 **Warning**

***Basin heaters systems will not prevent the coil from freezing.***

---

 **Caution**

***Unless some means of freeze prevention is incorporated into your system, the tower basin and exposed pipework should be drained at the beginning of each wintertime shutdown period.***

---

 **Warning**

***If tower basin is drained, verify that all basin heaters have been shut off either by automatic cutoff or disconnect switch.***

---

## Operation

### Protection Against Coil Freezing:

Ethylene and propylene glycol solutions are the best means to protect the coil from freezing. The following table provides the coil volume for each MH Fluid Cooler model. MHF706 and MHF707 coil volumes are for both coils added together.

Model	Coil Volume Liters	Model	Coil Volume Liters
MHF702_061	245	MHF705_061	890
MHF702_081	320	MHF705_081	1190
MHF702_101	395	MHF705_101	1475
MHF702_121	475	MHF705_121	1760
MHF702_062	285	MHF705_062	1080
MHF702_082	380	MHF705_082	1440
MHF702_102	455	MHF705_102	1780
MHF702_122	570	MHF705_122	2140
MHF703_061	320	MHF706_061	1475
MHF703_081	435	MHF706_081	1890
MHF703_101	530	MHF706_101	2310
MHF703_121	645	MHF706_121	2745
MHF703_062	380	MHF706_062	1800
MHF703_082	490	MHF706_082	2310
MHF703_102	625	MHF706_102	2840
MHF703_122	755	MHF706_122	3350
MHF704_061	605	MHF707_061	1705
MHF704_081	795	MHF707_081	2195
MHF704_101	985	MHF707_101	2685
MHF704_121	1175	MHF707_121	3180
MHF704_062	720	MHF707_062	2155
MHF704_082	945	MHF707_082	2665
MHF704_102	1190	MHF707_102	3425
MHF704_122	1420	MHF707_122	4055

When the use of industrial antifreeze solutions is not possible, the system must be operated to meet both of the following conditions.

1. Maintain sufficient flow rate through the coil.
2. Maintain sufficient heat load on the process fluid. Fluid exiting the coil must be maintained at or above 7°C. Cycling of the recirculation pump should not be used to control process temperatures.

---

## Maintenance

---

### Caution

***Draining the coil is not acceptable as a normal method of freeze protection—draining promotes corrosion inside the coil tubes. Draining is acceptable in an emergency if the coil is not protected by an antifreeze solution.***

It is recommended that you discuss your freeze prevention options with your local Marley sales representative.

---

### Water Treatment and Blowdown

#### Maintaining Water Quality:

The steel used in MH Fluid Cooler's has been galvanized with a heavy zinc coating averaging 2.0 mils in thickness. Other materials used (PVC fill, drift eliminators, and louvers, aluminum fans, cast iron Geareducer, etc.) are selected to offer maximum service life in a “normal” fluid cooler environment, defined as follows:

Recirculating water with a pH between 6.5 and 8; a chloride content (as NaCl) below 500 mg/L; a sulfate content (SO<sub>4</sub>) below 250 mg/L; total alkalinity (as CaCO<sub>3</sub>) below 500 mg/L; calcium hardness (as CaCO<sub>3</sub>) above 50 mg/L; no significant contamination with unusual chemicals or foreign substances; and adequate water treatment to minimize scaling.

- Startup Conditions: The water conditions during initial fluid cooler operation are crucial in preventing premature corrosion of galvanized steel (white rust). For at least the first eight weeks of operation, pH should be controlled between 6.5 and 8.0 with hardness and alkalinity levels between 100 and 300 mg/L (expressed as CaCO<sub>3</sub>).
- Chlorine (if used) shall be added intermittently, with a free residual not to exceed 1 mg/L—maintained for short periods. Excessive chlorine levels may deteriorate sealants and other materials of construction.
- An atmosphere surrounding the tower no worse than “moderate industrial”, where rainfall and fog are no more than slightly acid, and they do not contain significant chlorides or hydrogen sulfide (H<sub>2</sub>S).
- Many proprietary chemicals exist for control of scale, corrosion, and biological growth and should be used prudently. Also, combinations of chemicals may cause reactions which reduce treatment effectiveness, and certain chemicals such as surfactants, biodispersants and antifoams may increase drift rate.



---

## Maintenance

---

### Note

***The structure and coil of your fluid cooler consists primarily of galvanized steel, therefore your water treatment program must be compatible with zinc. In working with your water treatment supplier, it is important that you recognize the potential effects on zinc of the specific treatment program you choose.***

### Coil Louver Removal

The coil inlet louvers are comprised of a series of PVC pack assemblies, oriented to push water back into the fluid cooler. They are packed tightly to ensure no water escapes from the air inlet.

---

### ⚠ Caution

***Louver sheets can be very sharp and could cut skin if proper protection is not used. Always wear gloves and sleeves when handling louver packs.***

To remove the louvers, place both hands on the louver face and push up, this will indicate where one assembly stops and another starts. Push a single louver section up until it hits the top of the metal retaining channel (1). Pull the bottom side of the louver out away from the fluid cooler and remove the louver (2). Repeat this procedure for other packs to gain necessary access.



Proper louver pack replacement is essential to operation. Incorrect installation may result in excessive drift rates and fan inefficiency! To ensure packs are reinstalled in the correct orientation, it is recommended that one pack is left in its original location inside the fluid cooler as a reminder of pack orientation. Replace packs in the reverse procedure explained for removal. Place packs in the tower in the order they were removed. Packs should nest tightly with each other, leaving a level surface with no gaps.

---

## Maintenance

### Coil Eliminator Removal

The coil eliminators are comprised of a series of PVC pack assemblies, oriented to strip water from the air prior to leaving the fluid cooler. They are packed tightly to ensure no water escapes.

---

 **Caution**

***Eliminator sheets can be very sharp and could cut skin if proper protection is not used. Always wear gloves and sleeves when handling eliminator packs.***

To remove the eliminators, place both hands on the eliminator face and push up, this will indicate where one assembly stops and another starts. Push a single section up until it hits the top of the metal retaining channel (1). Push the bottom side of the pack down inside the fluid cooler (2). Turn the pack sideways and remove the eliminator (3). Repeat this procedure for other packs to gain necessary access.



Proper eliminator pack replacement is essential to operation. Incorrect installation may result in excessive drift rates and fan inefficiency! To ensure packs are reinstalled in the correct orientation, it is recommended that one pack is left in its original location inside the fluid cooler as a reminder of pack orientation. Place packs in the tower in the order they were removed. Packs should nest tightly with each other, leaving a level surface with no gaps.

---

## Maintenance

---

### Warning

#### Fluid Cooler Cleaning:

***Any evaporative-type fluid cooler must be thoroughly cleaned on a regular basis to minimize the growth of bacteria, including Legionella Pneumophila, to avoid the risk of sickness or death. Service personnel must wear proper personal protective equipment during decontamination. Do NOT attempt any service unless the fan motor is locked out.***

Operators of evaporative cooling equipment, such as closed circuit cooling towers, should follow maintenance programs which will reduce to an absolute minimum the opportunity for bacteriological contamination. Public Health Service officials have recommended that “good housekeeping” procedures be followed, such as: regular inspections for concentrations of dirt, scale, and algae; periodic flushing and cleaning; and the following of a complete water treatment program including biocidal treatment.

The visual inspection should take place at least once a week during the operating season. The periodic flushing and cleaning should be done before and after each cooling season, but in any event at least twice a year. The louvers, drift eliminators, easily accessible fill surfaces and the coil should be flushed by use of a moderate-pressure water nozzle, being careful not to cause physical damage. A reliable water treatment program should be installed and maintained. Filtration devices may be employed to reduce the suspended solids concentrations, thus increasing the effectiveness of the water treatment program. See Fluid Cooler Startup instructions on page 13.

#### Blowdown:

A fluid cooler cools water by continuously causing a portion of it to evaporate. Although the water lost by evaporation is replenished by the makeup system, it exits the tower as pure water—leaving behind its burden of dissolved solids to concentrate in the remaining water. Given no means of control, this increasing concentration of contaminants can reach a very high level.

In order to achieve water quality which is acceptable to the fluid cooler, the selected water treatment company must work from a relatively constant level of concentrations. This stabilization of contaminant concentrations is usually accomplished by blowdown, which is the constant discharge of a portion of the circulating water to waste. As a rule, acceptable levels on which to base



## Maintenance

a treatment schedule will be in the range of 2-4 concentrations. The following table shows the minimum amount of blowdown (percent of flow) required to maintain different concentrations with various cooling ranges\*:

Cooling Range	Number of Concentrations						
	1.5X	2.0X	2.5X	3.0X	4.0X	5.0X	6.0X
3°C	.7	.38	.25	.18	.11	.08	.06
6°C	1.5	.78	.51	.38	.25	.18	.14
8°C	2.3	1.18	.78	.58	.38	.28	.22
11°C	3.1	1.58	1.05	.78	.51	.38	.30
14°C	3.9	1.98	1.32	.98	.64	.48	.38

Multipliers are based on drift of 0.02% of the circulating water rate.

\* Range = Difference between hot water temperature and cold water temperature.

**EXAMPLE:** 160 m<sup>3</sup>/hr circulating rate, 10°C cooling range. To maintain 4 concentrations, the required blowdown is 0.458% or .00458 times 160 m<sup>3</sup>/hr, which is .73 m<sup>3</sup>/hr.

If fluid cooler is operated at 4 concentrations, circulating water will contain four times as much dissolved solid as the makeup water, assuming none of the solids form scale or are otherwise removed from the system.

---

### Note

***When water treatment chemicals are added, they should not be introduced into the circulating water system via the water collection basin of the cooling tower. Water velocities are lowest at that point, which results in inadequate mixing. An ideal location would be the redistribution basin above the coil.***

---

### Caution

***Any bolts removed functioning as mechanical or structural hardware should be replaced with the torques specified below.***

Fastener Torque Values				
Machine Bolt Size	Galvanized		Stainless	
	ft·lb <sub>f</sub>	N·m	ft·lb <sub>f</sub>	N·m
8mm	8	10	15	20
10mm	15	20	30	40
12mm	25	35	50	65
16mm	65	85	120	160
20mm	125	170	230	315

---

## Maintenance

### Belt Tensioning

See **Figure 1** and **Figure 2** for MH Fluid Cooler models MHF702 thru MHF705. Loosen specified hardware located at the top and bottom of the motor support assembly before adjusting the jacking screws. **Do not remove the hardware—it is required to support the motor.** Tighten the

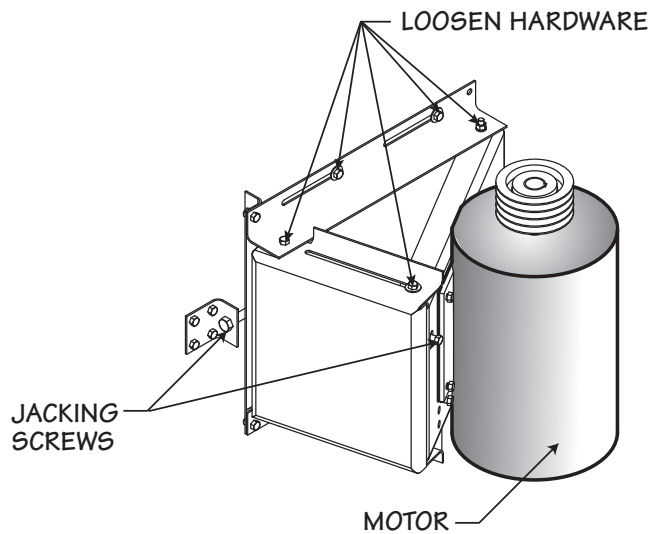

SINGLE MOTOR—TWO FANS

---

**Figure 1**

hardware after adjustment. Ideal tension is the lowest tension at which the belt will not slip under peak load conditions. Check tension frequently during the first 24-48 hours of run-in operation. Overtensioning shortens belt and bearing life. Keep belts free from foreign material which may cause slipping. Never apply belt dressing as this will damage the belt and cause early failure.

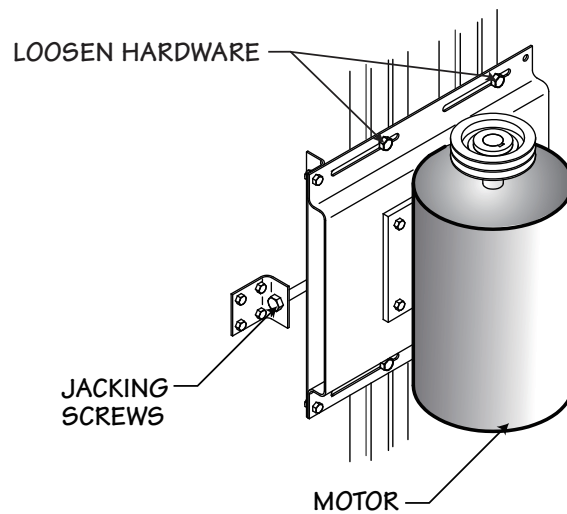

SINGLE MOTOR—SINGLE FAN

---

**Figure 2**

---

## Maintenance

A Dodge® V-Belt Tension Tester is an alternate method for tensioning V-belts. Check with you local belt supplier.

See **Figure 3** for MH Fluid Cooler models MHF706 and MHF707. The belts are adjusted by turning the threaded rod. Before tightening or loosening the belt, the double nuts holding the motor support in place must be loosened. There are two jam nuts at the end of the rod next to the casing. Turn the nut closest to the end of the rod to tighten the belt. Turn the other nut to loosen the belt. After achieving proper tension tighten the double nuts located on the fan side of the motor support against the motor support to maintain belt tension, then retighten the motor support nuts. Ideal tension is the lowest tension at which the belt will not slip under peak load conditions. Check tension frequently during the first 24-48 hours of run-in operation. Overtensioning shortens belt and bearing life. Keep belts free from foreign material which may cause slipping. Never apply belt dressing as this will damage the belt and cause early failure. A Dodge® V-Belt Tension Tester is an alternate method for tensioning V-belts. Check with you local belt supplier.

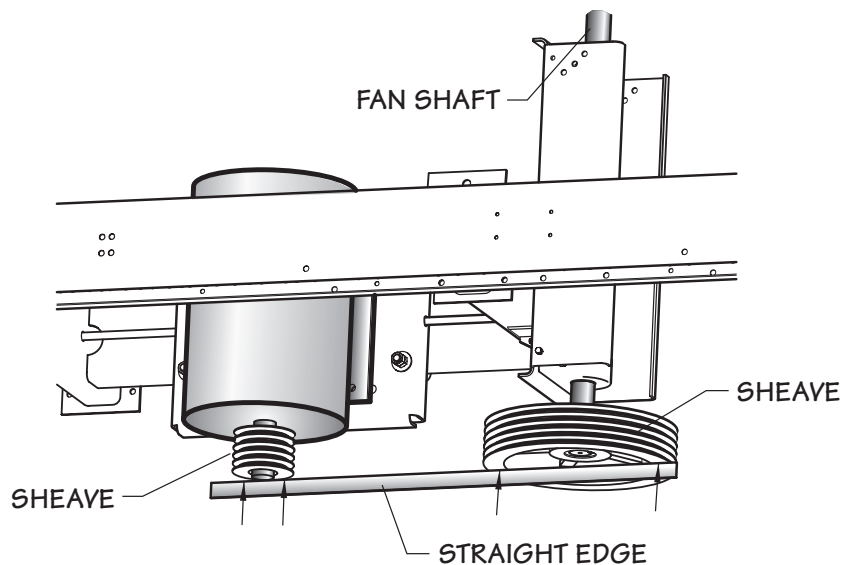

**Figure 3**

New belts (operating less than 8 hours) should be tensioned to the maximum value. Tension after this period should use no less than the minimum value. If the belt span was measured in inches, then use the pounds of force values. If the belt span was measured in centimeters, then use the kilograms of force values. If specific tensioning instructions are provided with your tensioning tool, those instructions should be used instead.



## Maintenance

Motor Sheave diameter	Used V-Belt minimum	New V-Belt maximum
85 cm - 105 cm	2.2 kg	3.3 kg
106 cm - 140 cm	3.2 kg	4.8 kg
141 cm - 220 cm	3.9 kg	5.7 kg

### Sheave Alignment

#### Warning

***Always shut off electrical power to the tower fan motor prior to performing any inspections that may involve physical contact with the mechanical or electrical equipment in or on the tower. Lock out and tag out any electrical switches to prevent others from turning the power back on. Service personnel must wear proper personal protective clothing and equipment.***

- The motor sheave is to be positioned as close as possible to the motor in order to minimize torque on the motor bushings.
- The motor and fan sheaves may have grooves that are not used. The bottom surface of the motor and fan sheaves must be aligned within 3 mm of each other and level within  $\frac{1}{2}^\circ$  (3 mm in 305 mm) in order to not adversely affect belt and sheave life.
- Alignment can be achieved by placing a straight edge across the top of the sheaves making sure that it is level and measuring down to the bottom surface of both sheaves at four points. See photo.
- The number of grooves on the motor and fan sheaves may not match each other, or the number of grooves on the belt. Always install the belts on the highest grooves on the fan sheave. Doing so will reduce the force on the fan shaft bearings, thus increasing their life.

#### Bushing Fastener Torque Values

Bushing	Fastener	Torque N·m
<b>SH</b>	$\frac{1}{4}$ - <b>20</b>	<b>8</b>
<b>SDS</b>	$\frac{1}{4}$ - <b>20</b>	<b>8</b>
<b>SD</b>	$\frac{1}{4}$ - <b>20</b>	<b>8</b>
<b>SK</b>	$\frac{5}{16}$ - <b>18</b>	<b>18</b>
<b>SF</b>	$\frac{3}{8}$ - <b>16</b>	<b>30</b>
<b>E</b>	$\frac{1}{2}$ - <b>13</b>	<b>47</b>
<b>F</b>	$\frac{9}{16}$ - <b>12</b>	<b>88</b>

---

## Maintenance

### Fluid Cooler Maintenance

Some maintenance procedures may require maintenance personnel to enter the fluid cooler. Each cased face of the fluid cooler has a door for access to the interior of the tower.

The optional fan deck ladder—models MHF706 and MHF707—is designed and intended solely for personnel to gain access to the fan deck. The fan deck ladder should not be used to enter or exit the access doors located on the cased face of the tower unless the optional access door platform is provided.

---

 **Warning**

***The purchaser or owner is responsible for providing a safe method for entering or exiting the access door. Use of the fan deck ladder to enter or exit the access doors may result in a fall.***

Included with this instruction packet are separate User Manuals on each major operating component of the tower, and it is recommended that you read them thoroughly. Where discrepancies may exist, the separate User Manuals will take precedence.

The following is recommended as a minimum routine of scheduled maintenance:

---

 **Warning**

***Always shut off electrical power to the tower fan motor prior to performing any inspections that may involve physical contact with the mechanical or electrical equipment in or on the tower. Lock out and tag out any electrical switches to prevent others from turning the power back on. Service personnel must wear proper personal protective clothing and equipment.***

**Weekly:** Inspect for bacterial growth and general operation conditions. Bacterial growth should be reported to your water treatment expert for immediate attention.

If equipped, the damper actuator and assembly should be cycled open and closed several times. Observe the cycle to assure that the blades and linkage move freely. Seasonal periods where the damper assembly remains open or closed for months at a time can allow pivot points to scale up, causing premature failure.



---

## Maintenance

**Monthly (Weekly at start up):** Observe, touch, and listen to the fluid cooler. Become accustomed to its normal appearance, sound, and level of vibration. Abnormal aspects relating to the rotating equipment should be considered reason to shut down the fluid cooler until the problem can be located and corrected. Observe operation of the motor, coupling (or drive shaft), Geareducer, if equipped and fan. Become familiar with the normal operating temperature of the motor(s), as well as the sight and sound of all components as a whole.

If equipped, check Geareducer oil level. Shut down the unit and allow 5 minutes for the oil level to stabilize. Add oil if required. Check for Geareducer oil leaks. Check the Geareducer as well as any optional oil lines to external oil dipstick/sight glass.

Inspect louvers, drift eliminators and basin trash screens and remove any debris or scale which may have accumulated. Replace any damaged or worn out components. Use of high-pressure water may damage the eliminator and louver material.

Observe operation of the float valve. Depress the operating lever to make sure that the valve is operating freely. Inspect the suction screen for plugging. Remove any debris that may have accumulated.

Check for any buildup of silt on the floor of the collection basin. Mentally make note of the amount, if any, so future inspections will enable you to determine the rate at which it is forming.

If equipped with dampers, lubricate the pivot points of the individual blades. Observe the area where the steel pivot pins penetrate the assembly's outer frame. The pin should rotate freely in the frame. In locations with severe hard water supply or climate, apply grease to the pivot points and linkage. This will both lubricate and seal out oxygen and moisture from the pivot points and help prevent hard water scale build-up.

**Every 3 months:** If equipped, lubricate fan shaft bearings. While rotating equipment by hand, grease the bearings until a bead forms around the seals—a maximum charge of 9 mL (MHF702-MHF704) and 41 mL (MHF706-MHF707) is recommended. Mobil SHC 460 grease is recommended.

---

## Maintenance

**Semi-Annually:** If equipped, check the belt tension and condition.

If equipped with dampers, lubricate jack shaft bearings and tiebar linkage with silicone lubricant. If dampers are equipped with pneumatic or electric actuators, the manufacturer's recommended maintenance procedures should be observed. If dampers are exposed to heavy dust-laden air, occasional flushing of the bearings with water is recommended.

Clean and disinfect cooling tower with biocides. Systems with biofouling, high general bacterial counts, or positive cultures of legionella may require additional cleaning. Refer to "Fluid Cooler Cleaning" section—page 24. Consult your water treatment expert as to prudent biological evaluation testing.

---

### Note

***Geareducer models used on MH Fluid Coolers are designed for 5-year oil change intervals. To maintain five-year change intervals, use only oil designed specifically for these Geareducers. If, after five years, turbine-type mineral oil is used, the oil must be changed semiannually. Refer to the Geareducer User Manual for oil recommendations and further instructions.***

**Annually:** Relubricate motor(s) according to the manufacturer's instructions. See instructions on the next page for towers with the motor located outside the plenum option.

Check to see that all bolts are tight in the fan and mechanical equipment region, including the fan cylinder and fan guard. Refer to Component User Manuals for torque values.

Inspect the fluid cooler thoroughly, making maximum use of instructions given in the separate user manuals. Check structural bolted connections and tighten as required. Make preventive maintenance repairs as necessary.

Check to see that all bolts are tight in the fan and mechanical equipment region, including the fan cylinder and fan guard. Refer to Component User Manuals for torque values.

**Every 5 Years:** If equipped, change Geareducer oil. Refer to the *Geareducer User Manual* for instructions.

---

## Maintenance

### Motor Relubrication Instructions

Motor located outside plenum option. Double-flow models MHF706 and MHF707 only.

**Open and lock out disconnect switch to make certain motor cannot be started.**

1. Remove guard as shown in **Figure 4**. Opposite end motor bearing is accessible from outside the tower.
2. Remove grease fill and relief plugs at both shaft extension end and opposite end bearings and remove hardened grease, using clean wire.

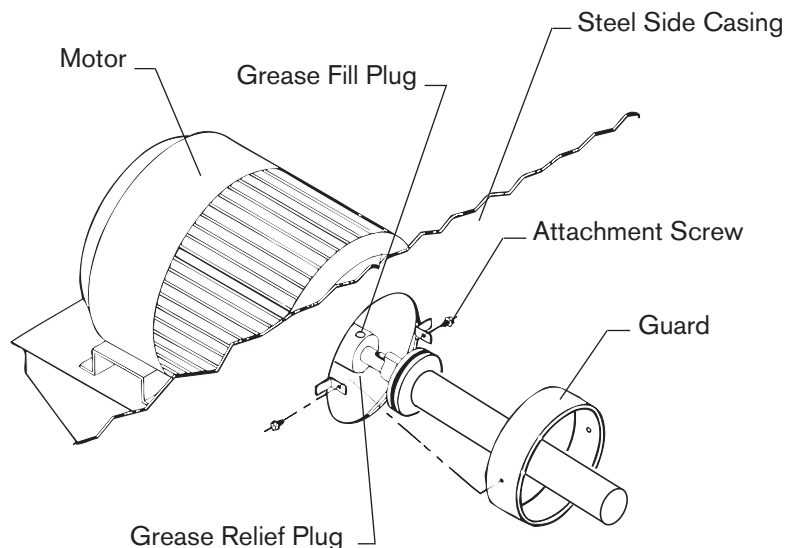

---

**Figure 4**

3. Insert grease fittings in grease fill openings and add grease until grease is forced out through relief openings.
4. Replace fill plugs and operate mechanical equipment 30 minutes to one hour to purge excess grease at grease relief opening.
5. Reinstall grease relief plugs and reinstall guard.
6. Resume normal fluid cooler operation.

### Seasonal Shutdown Instructions

When the system is to be shut down for an extended period of time, it is recommended that the recirculation water system be drained. Leave the basin drains open.



---

## Maintenance

---

### Caution

***Draining the coil is not recommended—draining promotes corrosion inside the coil tubes. See protecting coil in Freezing weather on page 20.***

During shutdown, clean the fluid cooler (see Warning, page 24) and make any necessary repairs. Eliminators and louvers are easily removed to gain access to the coil. Pay particular attention to mechanical equipment supports and sheaves or coupling (or drive shafts).

Following each year's shutdown and cleaning, inspect the fluid cooler's metal surfaces for evidence of the need to apply a protective coating. Do not misinterpret grime as a need to have the tower painted. If relatively bright metal can be exposed by cleaning, consider that the galvanizing has remained effective. Unless there is evidence of a generalized failure of the galvanizing, localized touch-up should be all that is required.

---

### Note

***To the extent that the galvanizing (zinc coating) still exists, paint will not adhere to it readily. Contact the manufacturer of the coating you intend to use for instructions.***

**Fluid cooler framework:** Check structural bolted connections and tighten as required.

**Fans:** Check fan assembly bolting and tighten as required. Use torque values prescribed in the *Fan User Manual*.

**Fans shaft bearings:** If equipped, lubricate fan shaft bearings at close of each operating season—see page 30.

**Electric motors:** Clean and lubricate motor at close of each operating season (refer to motor manufacturer's recommendations.) Check motor anchor bolts and tighten as required. See Page 32 for fluid coolers with motor located outside the plenum option.

---

### Caution

***Do not start motor before determining that there will be no interference with free rotation of the fan drive.***

The motor(s) should be operated for three hours at least once a month. This serves to dry out windings and re-lubricate bearing surfaces (refer to the Marley “**Electric Motor User Manual**” *Manual 92-1475* available at [spxcooling.com](http://spxcooling.com)).



---

## Maintenance

At start of new operating season, make sure bearings are adequately lubricated before returning motor to service.

### Long-Term Storage Procedures

Instructions for protection of non-operating equipment for more than 3 months.

After installation of the Fluid Cooler and completion of the pre-startup instructions, the operational availability of equipment will last for a maximum period of three months. Ensure that the tower and coil are completely drained of all water and process fluid.

After this initial period of 3 months, until the unit is employed into continuous operation, the fan shaft should be turned by hand for a few minutes every month after: Inject a small amount of grease into ball /roller bearings of fan shaft and drive components as per the manufacturer's recommendation attached.

### General Protective Requirements for Fluid Coolers

The fan opening at the top of the tower should be covered with a tarp. This will protect the mechanical components from rain as well as keep out dirt, trash, leaves, etc.

All coils on every fluid cooler model are protected from the environment by the structure of the tower as well as the PVC air inlet louvers. No external protection of the coil is required for long-term storage. For those units equipped with dampers, the blades of the dampers should be kept in closed position. Damper actuators must be removed and stored in a dry location to prevent condensation buildup inside the actuator.

### Internal Protection of Coil

All of the coil inlet and outlet connections should be sealed off with blind flanges. One flange per coil should be fitted with a valve, pressure gage and blocking plug. The coils should be charged with nitrogen gas to prevent corrosion. Connect a nitrogen supply line to the blind flange with valve. Loosen the bolts at one of the inlet nozzle blind flanges to let air escape. Inject inert gas into coil so as to effect nitrogen flushing for about 10 minutes and thus to expel all air out of the unit. Finally, re-tighten the inlet nozzle blind flange bolts and let nitrogen pressure build up to 48 kPa inside the tube-bundle. Disconnect the nitrogen line and plug the isolation valve to avoid any pressure drop in case of valve leak.

### Machinery Components

**Electric motors:** All drive motors should be taken down and stored indoors. Then, every month, turn motor shafts to evenly distribute lubricant to the bearing parts.

---

## Maintenance

**Recirculation pumps:** All pumps and pump motors should be taken down and stored indoors (pumps and motors may be stored fully assembled). Then, every month, turn pump impeller shaft to evenly distribute lubricant to the bearing parts.

**Belts:** Properly stored belts will retain their properties unchanged for several years. Under unfavorable storage conditions and with improper handling, deterioration of their physical properties will result. These changes can be caused, for example, oxidation, ozone, extreme temperatures, light, damp or solvents. It should be ensured that belts are stored stress free, which is to say without tension, pressure or other causes of deformation, as strain causes permanent deformation and failure due to fatigue, as well as cracking. If, for reasons of space, they are stored suspended, the diameter of the bar from which they are suspended must be equal to at least 10 times the height of the belt.

---

 **Caution**

***The belts may not be stored for longer than 3 month in an open, uncontrolled environment.***

### **Storage Area**

The storage area must be dry and dust-free. Belts may not be kept together with chemicals, solvents, fuels, lubricants, acids, etc.

### **Temperature**

Belts should be shielded from Radiators and their pipes. The distance between radiators and stored equipment must be at least 10 feet.

### **Light**

Belts should be protected from light, particularly from direct sunlight and strong artificial light with high ultraviolet content (formation of ozone), such as for example fluorescent tubes installed in open fixtures. Ideally, room lighting should be normal incandescent bulbs.

### **Ozone**

To counteract the damaging effect of ozone, the storage areas may not contain any form of ozone generating equipment, such as for example fluorescent light sources, mercury vapor lamps or electrical high voltage devices. Combustion gases and vapors, which may lead to ozone formation due to chemical processes, must be avoided or removed.

### **Dampness**

Damp storage areas are quite unsuitable. It should be ensured that no condensation occurs. The relative humid should be below 65 %.



---

## Maintenance

### Cleaning

Cleaning of dirty belts can be carried out with a mixture of glycerin and spirit in a ratio of 1:10.

---

 **Caution**

***Benzene, benzol, turpentine and similar substances may not be used. Furthermore, sharpened objects, wire brushes, emery paper etc., may not be used, as they will cause mechanical damage to the belts.***

**Ball / roller bearings:** Every month, turn the fan shaft and rotate by hand to distribute grease evenly over the bearing parts. Then, every three months, inject grease to prevent any blocking of the lubrication lines possibly due to grease hardening. Whenever the fan shaft has been turned, it is a must to secure them at a standstill.

**Fan units:** See manufacture's instructions in operation and maintenance manual of the Fan.

### **SPX Cooling Technologies Services**

Our interest in your MH Fluid Cooler does not end with the sale. Having conceived, designed, and manufactured the most reliable and longest-lasting fluid cooler of its class, we want to make sure that you gain the maximum possible benefit from its purchase.

Therefore, the following services are available which are intended to: assure the maximum possible service life under your operating conditions; tailor the operating characteristics to your specific needs—and maintain consistently optimum thermal performance capability. They are available by contacting your Marley sales representative.

---

## Maintenance

**Replacement parts:** A complete stock of parts and components is maintained at one or more of the various Marley plants. In cases of emergency, they can normally be shipped within 24 hours—by air freight if necessary. However, you would obviously benefit from anticipating your need in advance, thus avoiding the cost of special handling.

Be sure to mention your fluid cooler serial number (from the fluid cooler name-plate) when ordering parts.

**Periodic maintenance:** You may wish to contract with SPX Cooling for regularly scheduled visits—for the purpose of inspecting and reporting your fluid cooler's condition—to make recommendations intended to prevent emergencies— and to perform maintenance considered outside the norm.

This service is not intended to replace the important function performed by your maintenance staff. Their attention assures the fluid coolers's routine operating performance, and is invaluable. However, we recognize that the unusual manner in which a fluid cooler performs its function—as well as the unique forces which act upon it—may be considerations which occasionally require the services of an expert technician.

# Maintenance Schedule

Maintenance Service	Monthly	Semi-annually	Seasonal Startup or Annually
Inspect General Condition and Operation	<b>x</b>		<b>x</b>
<b>Observe Operation of:</b>			
Mechanical—motor, fan and drive mechanism	<b>x</b>		<b>x</b>
Makeup valve (if equipped)	<b>x</b>		<b>x</b>
Inspect for unusual noise or vibration	<b>x</b>		<b>x</b>
<b>Inspect and Clean:</b>			
Air inlet	<b>x</b>		<b>x</b>
PVC drift eliminators	<b>x</b>		<b>x</b>
Distribution basin, nozzles and collection basin	<b>x</b>		<b>x</b>
Fan and pump motor exterior	<b>x</b>		<b>x</b>
Coil surface		<b>x</b>	
<b>Check:</b>			
Collection water basin level	<b>x</b>		<b>x</b>
Blowdown—adjust as required	<b>x</b>		<b>x</b>
<b>Geareducer Drive (if equipped):</b>			
Check for loose fasteners including oil drain plug			<b>x</b>
Check oil level, check for / repair oil leaks	<b>x</b>		<b>x</b>
Change oil		<b>R</b>	
Make sure vent is open		<b>x</b>	<b>x</b>
Check driveshaft or coupling alignment			<b>x</b>
Check for loose driveshaft or coupling fasteners			<b>x</b>
Check driveshaft or coupling bushings or flex element for unusual wear		<b>x</b>	<b>x</b>
<b>Lube lines (if equipped):</b>			
Check for oil leaks in hoses or fittings	<b>x</b>	<b>R</b>	<b>x</b>
<b>Belt drive (if equipped):</b>			
Fan shaft bearing lubrication (every 3 mo.)		every 3 months	every 3 months
Check and tighten support fasteners			<b>x</b>
Check shaft, sheave and belt alignment			<b>x</b>
Check belt tension and condition		<b>x</b>	<b>x</b>
Check sheave bushing fastener torque			<b>x</b>
<b>Fan:</b>			
Check and tighten blade and hub fasteners			<b>x</b>
Check fan blade pitch and tip clearance			<b>x</b>
Check fan cylinder for loose fasteners			<b>x</b>
<b>Motor:</b>			
Lubricate (grease as required)			<b>R</b>
Check mounting bolts for tightness			<b>x</b>
Operate at least	3 hours a month	3 hours a month	3 hours a month
<b>Basin Heater (if equipped):</b>			
Check for proper operation of temp/low water level sensor			<b>x</b>
Inspect/clean buildup of contaminant from sensor		<b>x</b>	<b>x</b>
<b>Structure:</b>			
Inspect/tighten all fasteners		<b>x</b>	<b>x</b>
Inspect and touch up all metal surfaces			<b>x</b>

**R** — Refer to Component User Manual

**Note:** It is recommended at least weekly, that the general operation and condition be observed. Pay attention to any changes in sound or vibration that may signify a need for closer inspection.

# Troubleshooting

Trouble	Cause	Remedy
Motor will not start	Power not available at motor terminals	Check power at starter. Correct any bad connections between the control apparatus and the motor.
		Check starter contacts and control circuit. Reset overloads, close contacts, reset tripped switches or replace failed control switches.
		If power is not on all leads at starter, make sure overload and short circuit devices are in proper condition
	Wrong connections	Check motor and control connections against wiring diagrams.
	Low voltage	Check nameplate voltage against power supply. Check voltage at motor terminals.
	Open circuit in motor winding	Check stator windings for open circuits.
Unusual motor noise	Motor or fan drive stuck	Disconnect motor from load and check motor and fan drive for cause of problem.
	Rotor defective	Look for broken bars or rings.
	Motor running single-phase	Check motor and attempt to start it. Motor will not start if single-phased. Check wiring, controls and motor.
	Motor leads connected incorrectly	Check motor connections against wiring diagram on motor.
	Bad bearings	Check lubrication. Replace bad bearings.
	Electrical unbalance	Check voltages and currents of all three lines. Correct if required.
Motor runs hot	Air gap not uniform	Check and correct bracket fits or bearing.
	Rotor unbalance	Rebalance
	Cooling fan hitting end belt guard	Reinstall or replace fan.
	Wrong voltage or unbalanced voltage	Check voltage and current of all three lines against nameplate values.
	Overload	Check fan blade pitch. See Fan User Manual. Check for drag in fan drivetrain as from damaged bearings.
	Wrong motor RPM	Check nameplate against power supply. Check RPM of motor and drive ratio.
	Bearing overgreased	Remove bearing reliefs. Run motor up to speed to purge excessive grease.
	Wrong lubricant in bearings	Change to proper lubricant. See motor manufacturer's instructions.
	One phase open	Stop motor and attempt to start it. Motor will not start if single-phased. Check wiring, controls and motor.
	Poor ventilation	Clean motor and check ventilation openings. Allow ample ventilation around motor.
	Winding fault	Check with ohmmeter.
	Bent motor shaft	Straighten or replace shaft.
Motor does not come up to speed	Insufficient grease	Remove plugs and regrease bearings.
	Too frequent starting or speed changes	Limit cumulative accelerations time to a total of 30 seconds/hour. Set on/off or speed change set points farther apart. Consider installing a Marley VFD drive for fine temperature control.
	Deterioration of grease or foreign material in grease	Flush bearings and relubricate.
	Bearings damaged	Replace bearings.
	Voltage too low at motor terminals because of line drop	Check transformer and setting of taps. Use higher voltage on transformer terminals or reduce loads. Increase wire size or reduce inertia.
Wrong motor rotation	Broken rotor bars	Look for cracks near the rings. A new rotor may be required. Have motor service person check motor.
	Wrong sequence of phases	Switch any two of the three motor leads.

# Troubleshooting

Trouble	Cause	Remedy
Geareducer noise. (If equipped).	Geareducer bearings	If new, see if noise disappears after one week of operation. Drain flush, and refill Geareducer oil. See Geareducer User Manual. If still noisy, replace.
	Gears	Correct tooth engagement. Replace badly worn gears. Replace gears with broken or damaged teeth.
Unusual fan drive vibration	Loose bolts and cap screws	Tighten all bolts and cap screws on all mechanical equipment and supports.
	Unbalanced drive shaft or worn couplings. (If equipped)	Make sure motor and Geareducer shafts are in proper alignment and "match marks" properly matched. Repair or replace worn couplings. Rebalance drive shaft by adding or removing weights from balancing cap screws. See Driveshaft User Manual
	Fan	Make certain all blades are as far from center of fan as safety devices permit. All blades must be pitched the same. See Fan User Manual. Clean off deposit build-up on blades
	Worn Geareducer bearings. (If equipped)	Check fan and pinion shaft endplay. Replace bearings as necessary.
	Worn fan shaft bearings. (Belt drive).	Check fan shaft endplay. Replace bearings as necessary.
	Unbalanced motor	Disconnect load and operate motor. If motor still vibrates, rebalance rotor.
	Bent Geareducer shaft. (If equipped).	Check fan and pinion shaft with dial indicator. Replace if necessary.
Fan noise	Blade rubbing inside of fan cylinder	Adjust cylinder to provide blade tip clearance
	Loose bolts in blade clamps	Check and tighten if necessary.
	Fan shaft bearing. (Belt drive).	Grease bearings.
Scale or foreign substance in circulating water system	Insufficient blowdown	See "Water Treatment" section of this manual.
	Water treatment deficiency	Consult competent water treating specialist. See "Water Treatment" section of this manual
Cold water temperature too warm.	Entering wet bulb temperature is above design	Check to see if local heat sources are affecting fluid cooler. See if surrounding structures are causing recirculation of tower discharge air. Discuss remedy with Marley representative.
	Design wet bulb temperature was too low.	May have to increase fluid cooler size. Discuss remedy with Marley representative
	Actual process load greater than design	May have to increase fluid cooler size. Discuss remedy with Marley representative
See "Tower Operation."	Overpumping	Reduce water flow rate over fluid cooler to design conditions.
Excessive drift exiting fluid cooler	Fluid cooler starved for air	Check motor current and voltage to be sure of correct contract horsepower. Repitch fan blades if necessary. Clean louvers, fill and eliminators. Check to see if nearby structures or enclosing walls are obstructing normal airflow to fluid cooler. Discuss remedy with Marley representative.
	Distribution basins overflowing	Reduce water flow rate over fluid cooler to design conditions. Be sure distribution water basin nozzles are in place and not plugged.
	Faulty drift elimination	Check to see that integral fill. Louvers and eliminators are clean, free of debris and installed correctly. If drift eliminators are separate from fill, make sure they are correctly installed and in place. Clean if necessary. Replace damaged or worn out components



---

## Additional Information

**Increased load requirements:** MH Fluid Coolers are designed so that cells of either equal or unequal capacity can be added in the future. This allows you to compensate for the load increases that normally occur with the replacement or addition of production equipment—and still retain continuity with respect to your fluid cooler system.

**Fluid cooler rebuilding:** SPX routinely rebuilds and upgrades fluid coolers and cooling towers of all materials and manufacture. If your product ever reaches the limit of its service life, we recommend that you investigate the cost of rebuilding before you routinely order a new replacement tower.

Each MH Fluid Cooler includes a document package containing general orientation drawings, and tower component manuals. These documents contain important information relating to safe installation and operation of the fluid cooler. Field installation is required for fan guards (double flow models), piping inlets and piping outlets. Some optional accessories, such as handrails, ladders and safety cages may also require field installation. A separate installation drawing or manual for each purchased option is included in the document package along with bills of material. If you have purchased an option and can't find the appropriate installation drawing, contact your local Marley sales representative before proceeding.

In addition to these specific documents, numerous technical reports are published by SPX including more detailed information on a variety of cooling tower and fluid cooler operation and service topics. Your Marley sales representative will be happy to give you copies of these reports at no charge or you can download copies from our website at [spxcooling.com](http://spxcooling.com).

For complete parts and service assistance, contact the Marley sales representative in your area. If you need help locating your representative, please phone 60 3 7947 7800 or check the internet at [spxcooling.com](http://spxcooling.com).





**SPX**<sup>®</sup>

**COOLING TECHNOLOGIES**

SPX COOLING TECHNOLOGIES MALAYSIA Sdn Bhd

UNIT 505, BLOCK B, PHILEO DAMANSARA 2 | NO. 15 JALAN 16/11, OFF JALAN DAMANSARA | 46350 PETALING JAYA, MALAYSIA | 60 3 7947 7800 | [spxcooling.com](http://spxcooling.com)

In the interest of technological progress, all products are subject to design and/or material change without notice.  
©2010 SPX Cooling Technologies

sea\_M05-116F