

MCW cooling tower

engineering data
and specifications



Engineering Data

Schematic	6
Support	16
Noise Attenuator Option	18
Hoisting Info	19
Freeze Prevention	20
Water Quality	21

Specifications / Base

Base	22
Thermal Performance	22
Performance Warranty	22
Design Loading	23
Construction	23
Mechanical Equipment	23
Fill, Louvers and Drift Eliminators	24
Hot Water Distribution System	25
Casing	25
Access	25
Collection Basin	25
Warranty	25

Specifications / Options

Stainless Steel Options	
Stainless Steel Collection Basin	26
All Stainless Steel Cooling Tower	26
Convenience and Safety Options	
Top Access Platform	26
Ladder Extension	27
Ladder Safety Cage	27
Access Door Platform	27
Distribution System Access Platform	27
Control Options	
Fan Motor Starter Control Panel	28
Vibration Limit Switch	28
Basin Heater	29
Fan Motor Variable Speed Drive	29
Marley Premium VFD System	30
Miscellaneous Options	
Sound Control	32
Premium Efficiency Motor	33
Discharge Hood	33

AIR MOVEMENT PACKAGE

- Forward-curved centrifugal fans are dynamically balanced and mounted on tubular steel shafts
- Fans are supported by roller-bearings mounted at both ends with heavy-gauge steel supports.
- Spherical roller bearings are rated at an L₁₀ life of 50,000 hours.
- Fan guard / Air-inlet screens are 16 gauge galvanized steel.
- TEFC Fan Motor—1.0 service factor, variable torque, and specially insulated for cooling tower duty.
- The MCW Series air movement package including the structural support—guaranteed against failure for a period of five full years. The motor is warranted separately by the motor manufacturer.

WATER DISTRIBUTION SYSTEM

- Pressurized spray system distributes water evenly over the fill.
- Low-clog polypropylene nozzles—delivers precise distribution of water over the fill area.
- Marley MC thermoformed PVC film fill assembled into packs for ease of removal and cleaning.
- Marley XCEL drift Eliminators—limit drift losses to no more than .005% of the design m³/hr flow rate.

STRUCTURE

- Forced-draft, counter-flow design requires considerably less plan area than crossflow towers typically use.
- Series 300 stainless steel, 316 stainless steel or Z725 galvanized steel construction.
- Factory assembled—ensures final field installation will be hassle-free.
- Centrifugal fans and a fully-enclosed falling water area create one of the quietest cooling tower configurations on the market.



MCW Series towers are galvanized steel, factory assembled, forced draft, counterflow cooling towers, designed to serve air conditioning and refrigeration systems as well as light to medium industrial process loads on clean water. The Marley MCW cooling tower is particularly suited to the urban environment, reducing noise while increasing energy efficiency and performance.

The specifications portion of this publication not only relates the language to use in describing an appropriate MCW cooling tower—but also defines why certain items and features are important enough to specify with the intention of insisting upon compliance by all bidders. The left hand column of pages 22 thru 31 provides appropriate text for the various specification paragraphs, whereas the right hand column comments on the meaning of the subject matter and explains its value.

Pages 22 thru 25 indicate those paragraphs which will result in the purchase of a basic cooling tower—one that accomplishes the specified thermal performance, but which will lack many operation—and maintenance-enhancing accessories and features that are usually desired by those persons who are responsible for the continuing operation of the system of which the cooling tower is part. It will also incorporate those standard materials which testing and experience has proven to provide acceptable longevity in normal operating conditions.

Pages 26 thru 31 provide paragraphs intended to add those features, components, and materials that will customize the cooling tower to meet the user's requirements.

Use this data for preliminary layouts only. Obtain current drawing from your Marley sales representative.

CoolSpec™ web-based selection software, available at coolspec.com provides MCW model recommendations based on customer's specific design requirements.

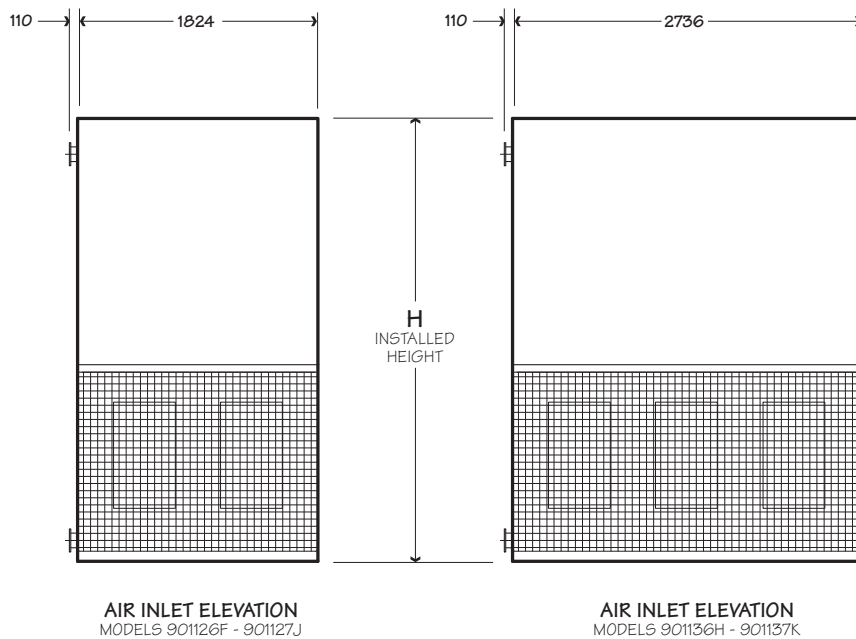
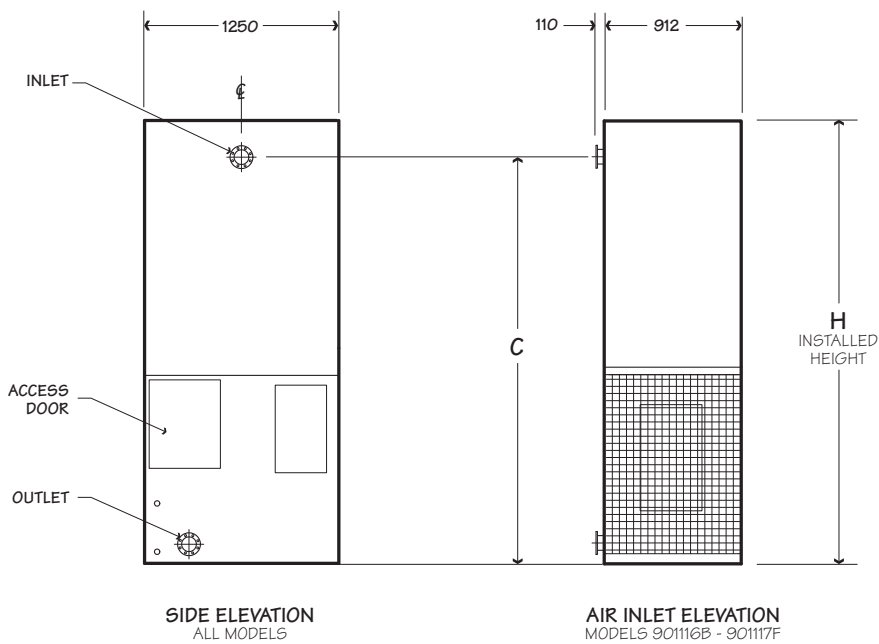

Model note 2	Nominal Tons note 3	Motor kW	Dimensions				Design Operating Weight kg	Shipping Weight kg	
			C	H	M	Inlet / Outlet dia		Weight/Cell	Heaviest Section
901116B-1	18	1.1	2285	2555	240	2½"	733	580	336
901116C-1	20	1.5	2285	2555	240	2½"			
901116D-1	23	2.2	2285	2555	240	2½"			
901117D-1	26	2.2	2585	2555	240	2½"			
901117F-1	31	3.7	2585	2555	240	2½"			
901126F-1	45	3.7	2255	2555	240	3"	1156	836	456
901126H-1	50	5.5	2255	2555	240	3"			
901127H-1	57	5.5	2555	2555	240	3"			
901127J-1	62	7.5	2555	2555	240	3"			
901136H-1	66	5.5	2270	2555	600	4"	1588	1092	576
901136J-1	75	7.5	2270	2555	600	4"			
901137H-1	75	5.5	2570	2855	600	4"			
901137J-1	85	7.5	2570	2855	600	4"			
901137K-1	93	11.0	2570	2855	600	4"			

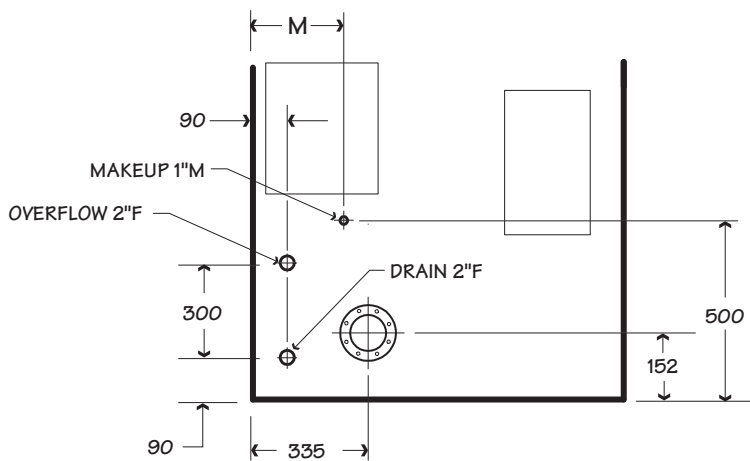

PIPING CONNECTIONS
ALL MODELS

NOTE

- 1 Use this bulletin for preliminary layouts only. Obtain current drawings from your Marley sales representative. All table data is per cell.
- 2 Last numeral of model number indicates number of cells. Change as appropriate for your selection.
- 3 Nominal cooling capacity based upon 35°C HW, 29.5°C CW, 25.5°C WB and .68 m³/hr per ton. The Marley CoolSpec web-based selection software provides MCW model recommendations based on specific design requirements.
- 4 Standard overflow is a 2" dia. F connection located on the side of the collection basin. Makeup water connection is 1" dia. M connection located on the side of the collection. A 2" F drain connection is located on the side of the collection basin and two 2" F drain connections are located on the basin floor.

Use this data for preliminary layouts only. Obtain current drawing from your Marley sales representative.

CoolSpec™ web-based selection software, available at coolspec.com provides MCW model recommendations based on customer's specific design requirements.

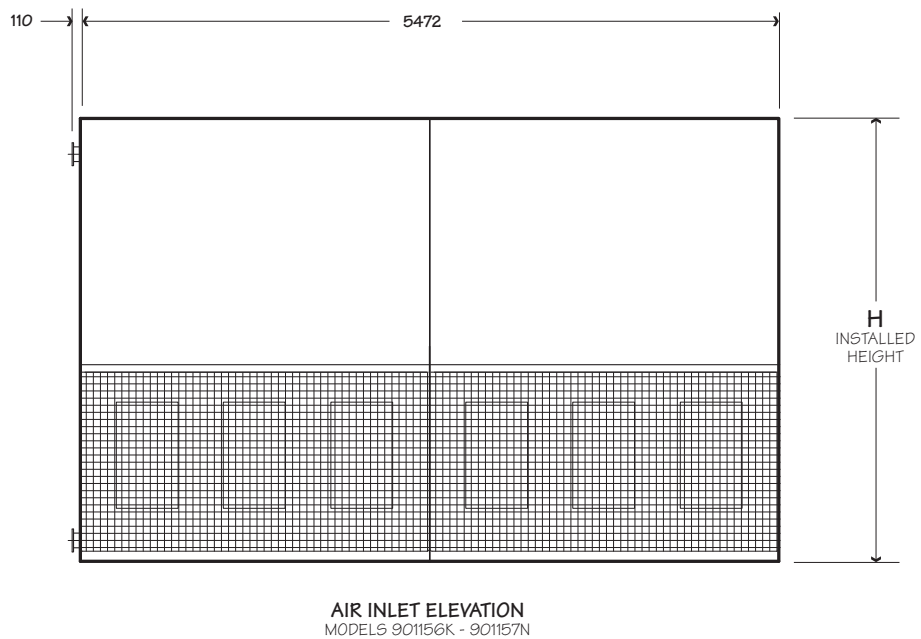
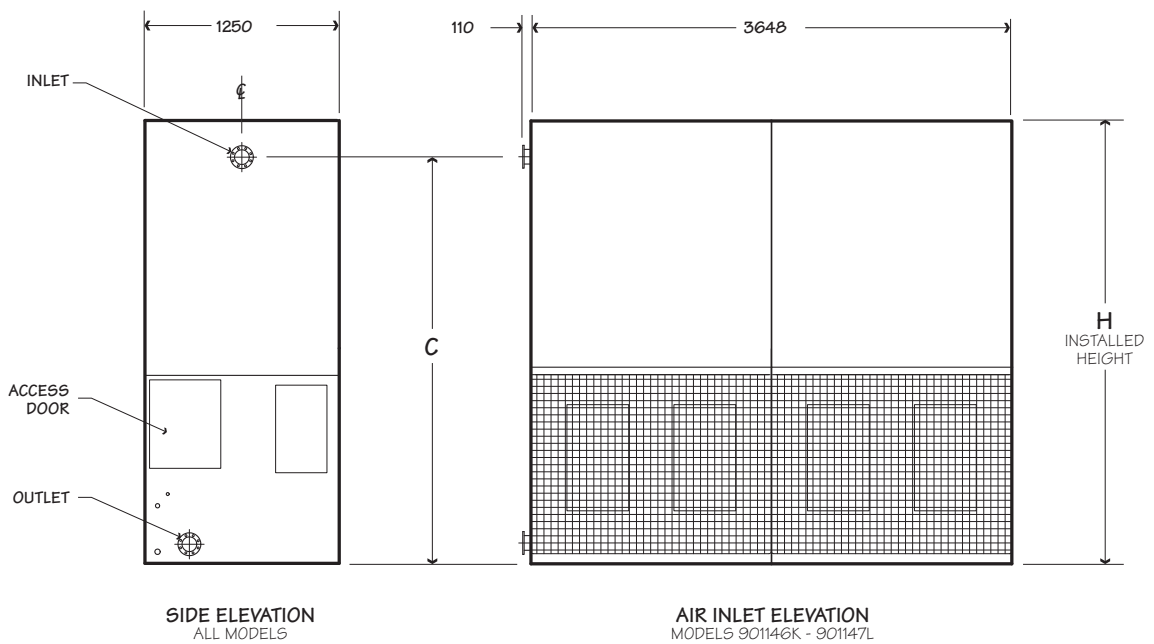

Model note 2	Nominal Tons note 3	Motor kW	Dimensions			Design Operating Weight kg	Shipping Weight kg	
			C	H	Inlet / Outlet dia		Weight/Cell	Heaviest Section
901146K-1	102	2 x 5.5	2285	2555	6"	2006	1351	696
901147K-1	117	2 x 5.5	2585	2855	6"			
901147L-1	125	2 x 7.5	2585	2855	6"			
901156K-1	134	2 x 5.5	2300	2555	6"	2586	1866	937
901156L-1	150	2 x 7.5	2300	2555	6"			
901157L-1	170	2 x 7.5	2600	2855	6"			
901157N-1	187	2 x 11	2600	2855	6"			

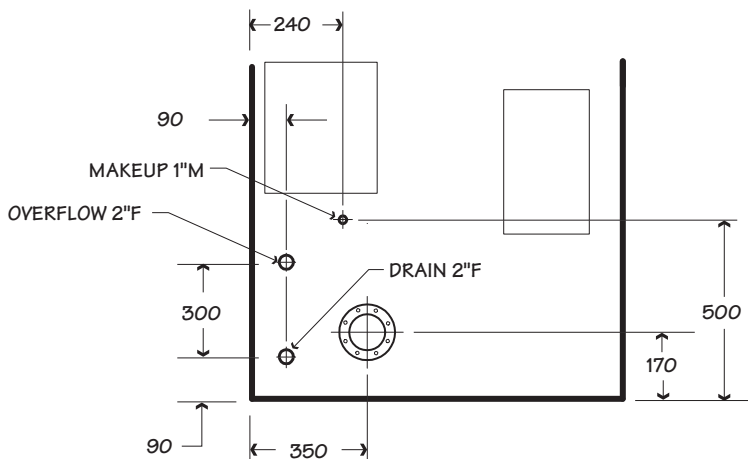

PIPING CONNECTIONS
ALL MODELS

NOTE

- 1 Use this bulletin for preliminary layouts only. Obtain current drawings from your Marley sales representative. All table data is per cell.
- 2 Last numeral of model number indicates number of cells. Change as appropriate for your selection.
- 3 Nominal cooling capacity based upon 35°C HW, 29.5°C CW, 25.5°C WB and .68 m³/hr per ton. The Marley CoolSpec web-based selection software provides MCW model recommendations based on specific design requirements.
- 4 Standard overflow is a 2" dia. F connection located on the side of the collection basin. Makeup water connection is 1" dia. M connection located on the side of the collection. A 2" F drain connection is located on the side of the collection basin and four 2" F drain connections are located on the basin floor.

Use this data for preliminary layouts only. Obtain current drawing from your Marley sales representative.

CoolSpec™ web-based selection software, available at coolspec.com provides MCW model recommendations based on customer's specific design requirements.

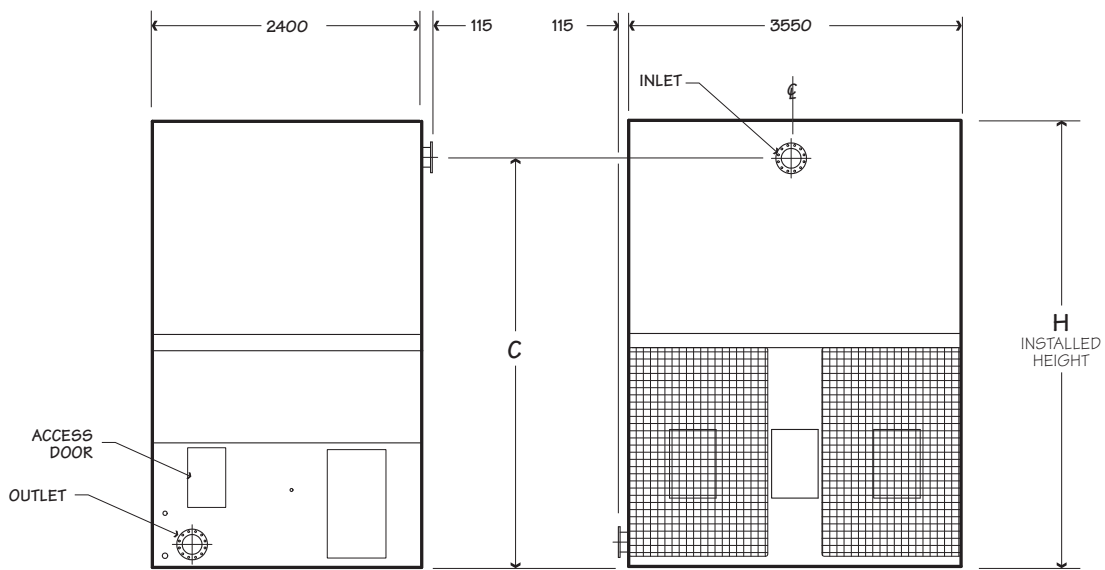

SIDE ELEVATION
ALL MODELS

AIR INLET ELEVATION
MODELS 901546M - 901549P

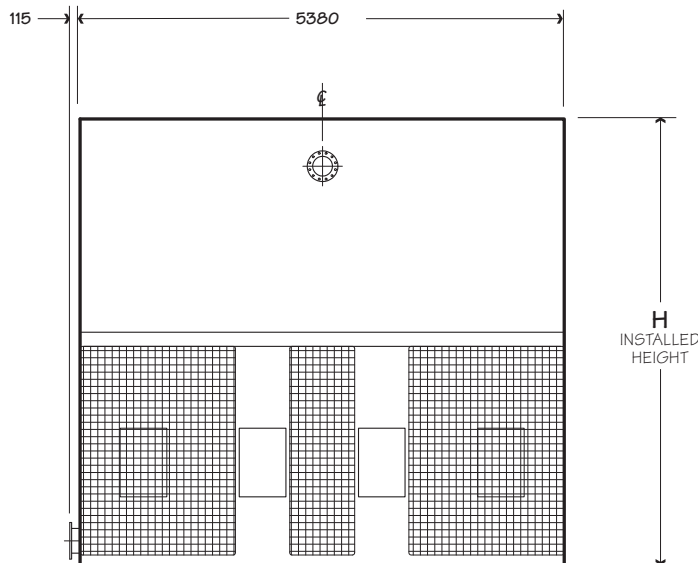

AIR INLET ELEVATION
MODELS 901556N - 901558R

Model note 2	Nominal Tons note 3	Motor kW	Dimensions			Design Operating Weight kg	Shipping Weight kg	
			C	H	Inlet / Outlet dia		Weight/Cell	Heaviest Section
901546M-1	214	18.5	3770	4070	8"	4271	3084	1820
901546N-1	225	22	3770	4070	8"			
901547M-1	239	18.5	4200	4500	8"			
901547N-1	253	22	4200	4500	8"			
901548N-1	270	22	4200	4500	8"			
901548P-1	298	30	4200	4500	8"			
901549P-1	309	30	4510	4810	8"	5931	4118	2417
901556N-1	286	2 x 11	3595	3895	8"			
901556P-1	315	2 x 15	3770	4070	8"			
901556Q-1	336	2 x 18.5	3770	4070	8"			
901557Q-1	379	2 x 18.5	4200	4500	8"			
901557R-1	400	2 x 22	4200	4500	8"			
901558R-1	429	2 x 22	4200	4500	8"			

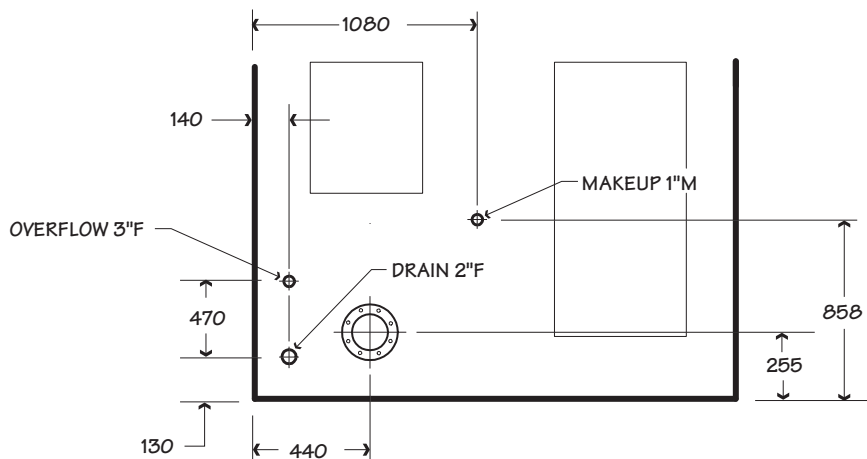

PIPING CONNECTIONS
ALL MODELS

NOTE

- 1 Use this bulletin for preliminary layouts only. Obtain current drawings from your Marley sales representative. All table data is per cell.
- 2 Last numeral of model number indicates number of cells. Change as appropriate for your selection.
- 3 Nominal cooling capacity based upon 35°C HW, 29.5°C CW, 25.5°C WB and .68 m³/hr per ton. The Marley CoolSpec web-based selection software provides MCW model recommendations based on specific design requirements.
- 4 Standard overflow is a 3" dia. F connection located on the side of the collection basin. Makeup water connection is 1" dia. M connection located on the side of the collection. A 2" F drain connection is located on the side of the collection basin.

Use this data for preliminary layouts only. Obtain current drawing from your Marley sales representative.

CoolSpec™ web-based selection software, available at coolspec.com provides MCW model recommendations based on customer's specific design requirements.

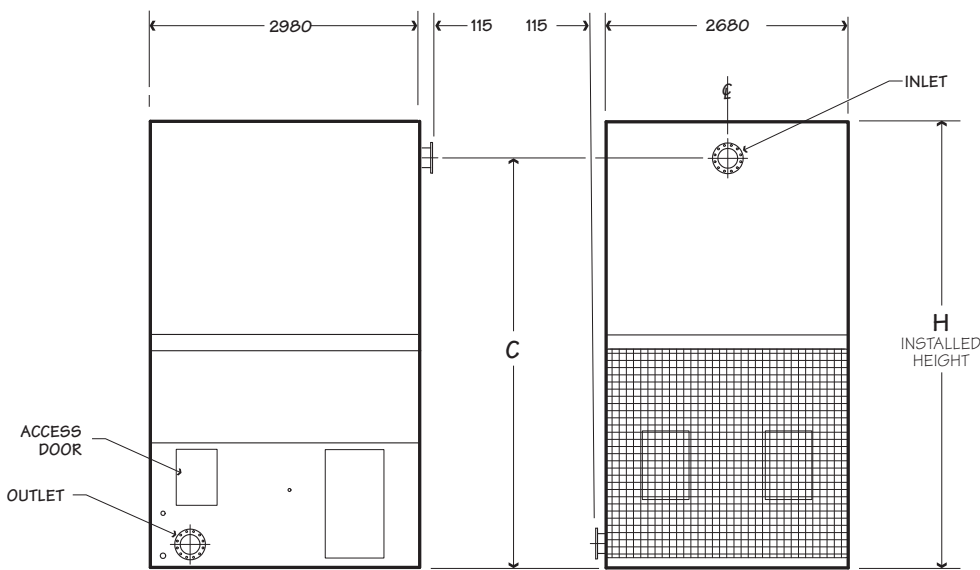

SIDE ELEVATION
ALL MODELS

AIR INLET ELEVATION
MODELS 901731L - 901738N

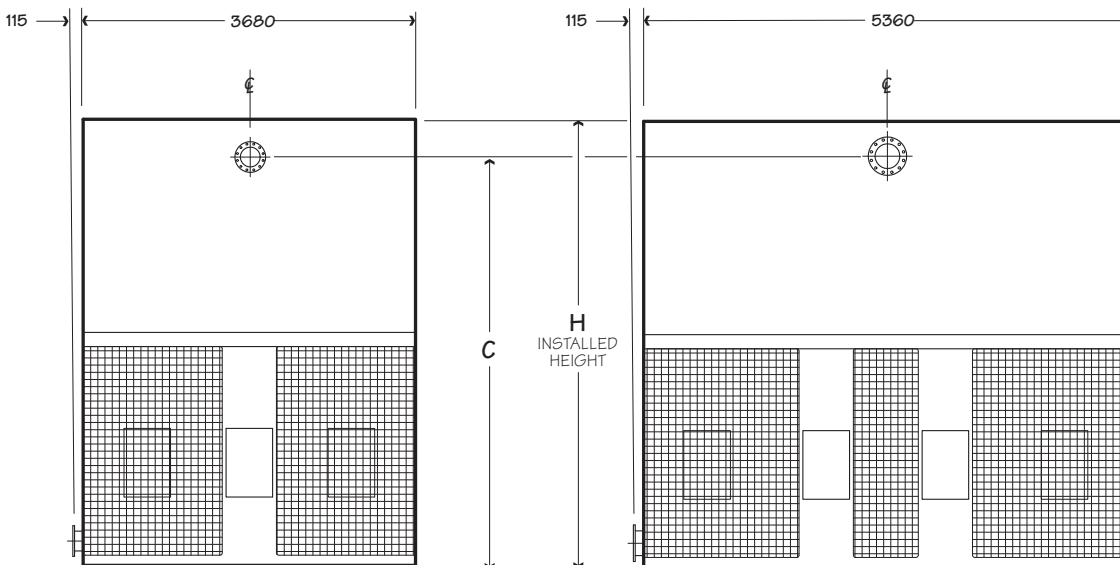

AIR INLET ELEVATION
MODELS 901746N - 901748Q

AIR INLET ELEVATION
MODELS 901756Q - 901758R

Model note 2	Nominal Capacity kW note 3	Motor kW	Dimensions			Design Operating Weight kg	Shipping Weight lb	
			C	H	Inlet / Outlet dia		Weight/Cell	Heaviest Section
901731K-1	32	11	3660	3960	8"	4203	2853	1634
901732L-1	41	15	3960	4260	8"			
901732M-1	43	18.5	3960	4260	8"			
901736L-1	40	15	3660	3960	8"			
901736M-1	43	18.5	3660	3960	8"			
901737N-1	50	22	3960	4260	8"			
901738N-1	53	22	4260	4560	8"	5510	3641	2176
901746N-1	59	22	3660	3960	8"			
901747N-1	65	22	3960	4260	8"			
901747P-1	71	30	3960	4260	8"			
901748P-1	77	30	4260	4560	8"			
901748Q-1	81	37	4260	4560	8"			
901756Q-1	87	2 x 18.5	3660	3985	10"	7710	4969	2838
901757Q-1	95	2 x 18.5	3960	4285	10"			
901757R-1	99	2 x 22	3960	4285	10"			
901758R-1	107	2 x 22	4260	4585	10"			

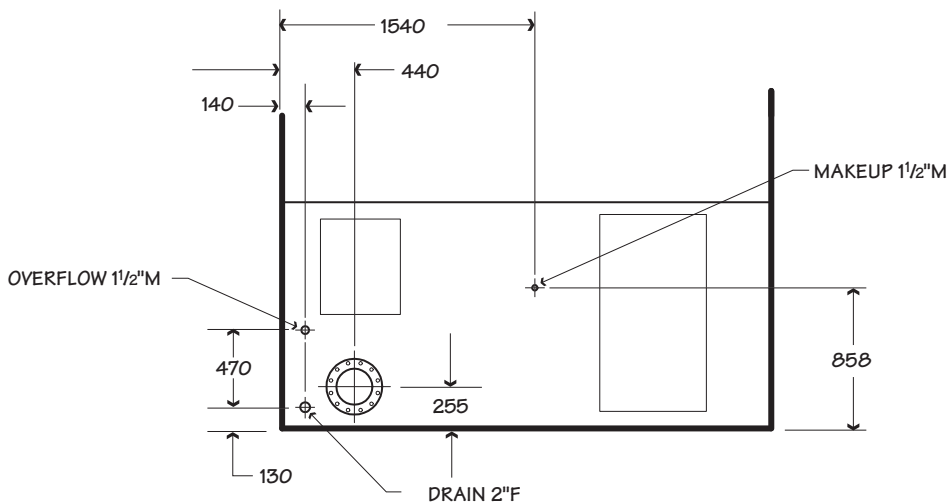

PIPING CONNECTIONS
ALL MODELS

NOTE

- 1 Use this bulletin for preliminary layouts only. Obtain current drawings from your Marley sales representative. All table data is per cell.
- 2 Last numeral of model number indicates number of cells. Change as appropriate for your selection.
- 3 Nominal cooling capacity based upon 35°C HW, 29.5°C CW, 25.5°C WB and .68 m³/hr per ton. The Marley **CoolSpec** web-based selection software provides MCW model recommendations based on specific design requirements.
- 4 Standard overflow is a 1 1/2" dia. M connection located on the side of the collection basin. Makeup water connection may be 1 1/2" dia. M connection located on the side of the collection. Drain is a 2" F connection located on the side of the collection basin.

Use this data for preliminary layouts only. Obtain current drawing from your Marley sales representative.

CoolSpec™ web-based selection software, available at coolspec.com provides MCW model recommendations based on customer's specific design requirements.

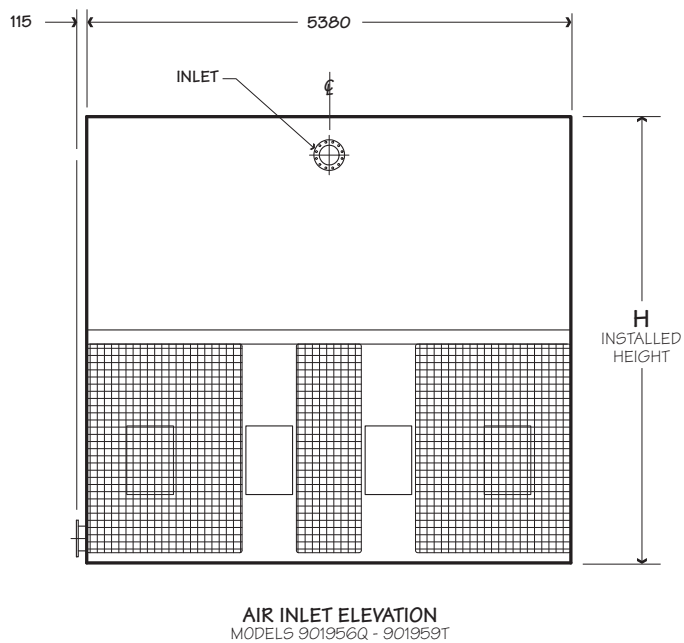
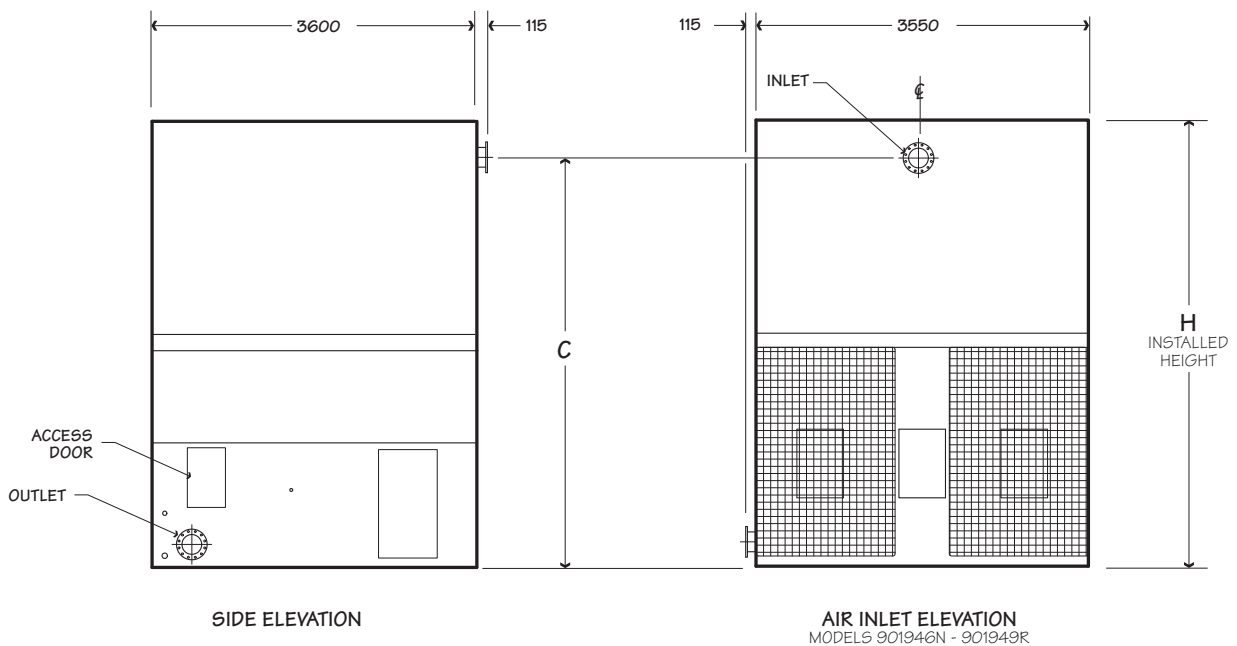

Model note 2	Nominal Tons note 3	Motor kW	Dimensions			Design Operating Weight kg	Shipping Weight kg	
			C	H	Inlet / Outlet dia		Weight/Cell	Heaviest Section
901946N-1	251	22	3730	4030	8"	6311	3895	2227
901946P-1	275	30	3730	4030	8"			
901947N-1	280	22	3960	4260	8"			
901947P-1	309	30	3960	4260	8"			
901948N-1	307	22	4260	4560	8"			
901948P-1	340	30	4260	4560	8"			
901949P-1	358	30	4690	4990	8"			
901949Q-1	389	37	4690	4990	8"			
901949R-1	416	45	4690	4990	8"			
901956Q-1	375	2 x 18.5	3730	4055	10"	9270	5580	2965
901956R-1	401	2 x 22	3730	4055	10"			
901957Q-1	411	2 x 18.5	3960	4285	10"			
901957R-1	434	2 x 22	3960	4285	10"			
901958Q-1	463	2 x 18.5	4260	4585	10"			
901958R-1	491	2 x 22	4260	4585	10"			
901959R-1	513	2 x 22	4690	5015	10"			
901959S-1	567	2 x 30	4690	5015	10"			
901959T-1	600	2 x 37	4690	5015	10"			

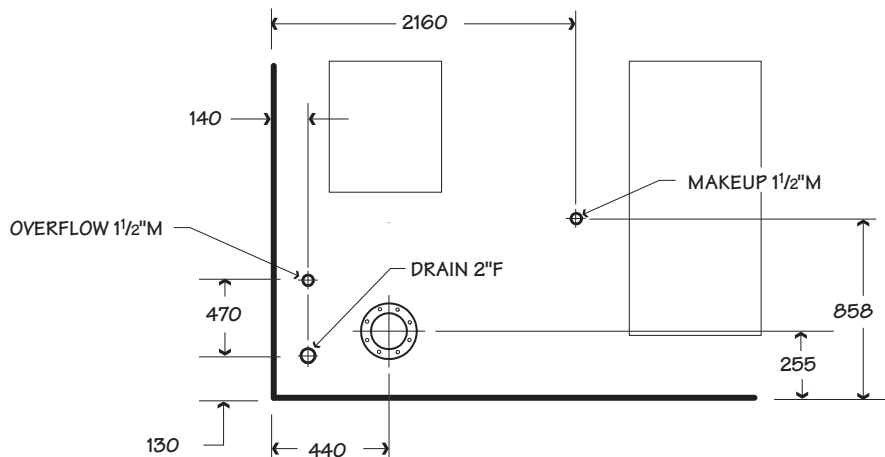

PIPING CONNECTIONS
ALL MODELS

NOTE

- 1 Use this bulletin for preliminary layouts only. Obtain current drawings from your Marley sales representative. All table data is per cell.
- 2 Last numeral of model number indicates number of cells. Change as appropriate for your selection.
- 3 Nominal cooling capacity based upon 35°C HW, 29.5°C CW, 25.5°C WB and .68 m³/hr per ton. The Marley CoolSpec web-based selection software provides MCW model recommendations based on specific design requirements.
- 4 Standard overflow is a 1 1/2" dia. M connection located on the side of the collection basin. Makeup water connection may be 1 1/2" dia. M connection located on the side of the collection. Drain is a 2" F connection located on the side of the collection basin.

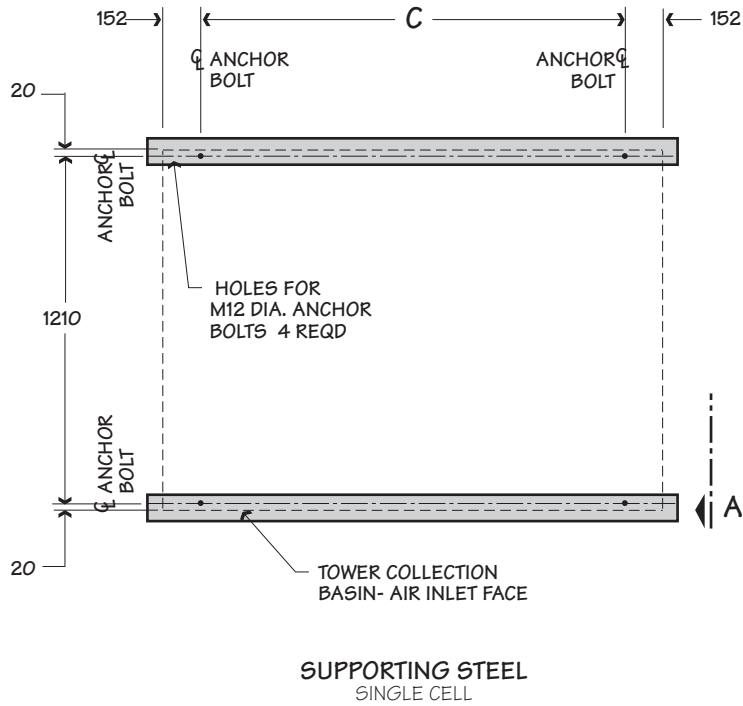

Model	C
90111	608
90112	1520
90113	2432
90114	3344
90115	5168

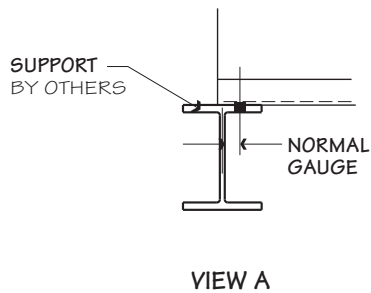

NOTE

- 1 **Use this bulletin for preliminary layouts only.** Obtain current drawings from your Marley sales representative for final design.
- 2 Purchaser to provide tower support complete with holes and anchor bolts. Do not use studs! Anchor points must be framed flush and level at top.
- 3 Tower may be placed on a flat concrete slab.

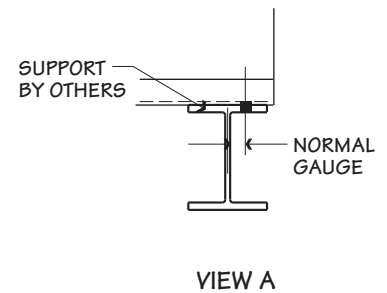
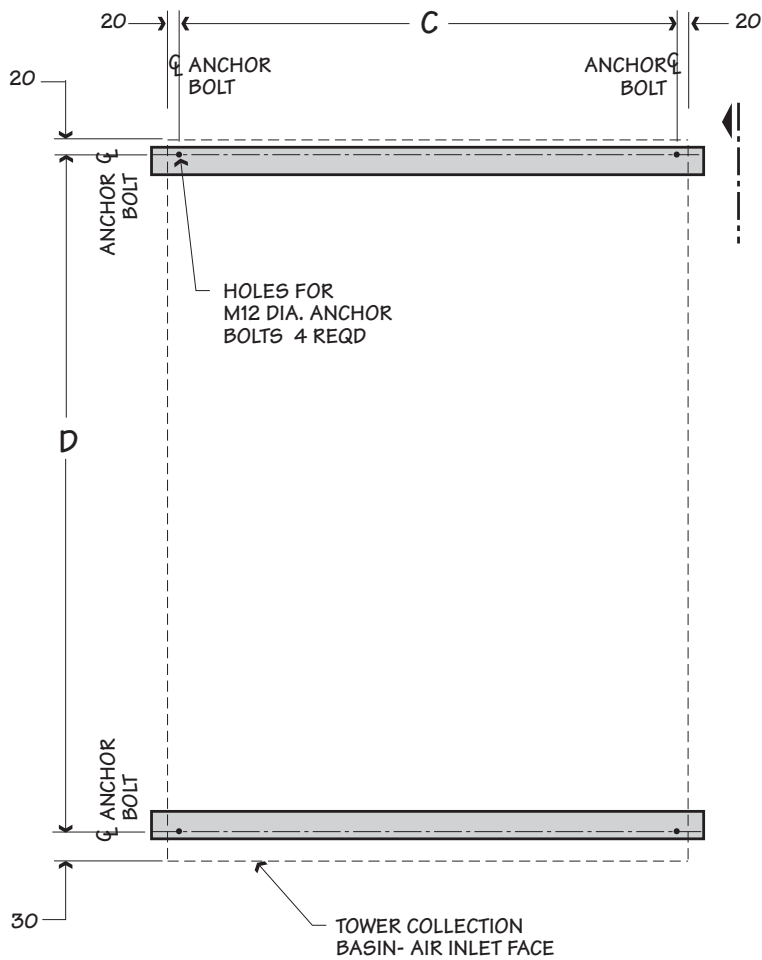

SUPPORTING STEEL
SINGLE CELL

Model	C	D
90154	3510	2360
90155	5340	2360
90173	2640	2931
90174	3640	2931
90175	5320	2931
90194	3510	3561
90195	5340	3561

NOTE

- 1 **Use this bulletin for preliminary layouts only.** Obtain current drawings from your Marley sales representative for final design.
- 2 Purchaser to provide tower support complete with holes and anchor bolts. Do not use studs! Anchor points must be framed flush and level at top.
- 3 Tower may be placed on a flat concrete slab.

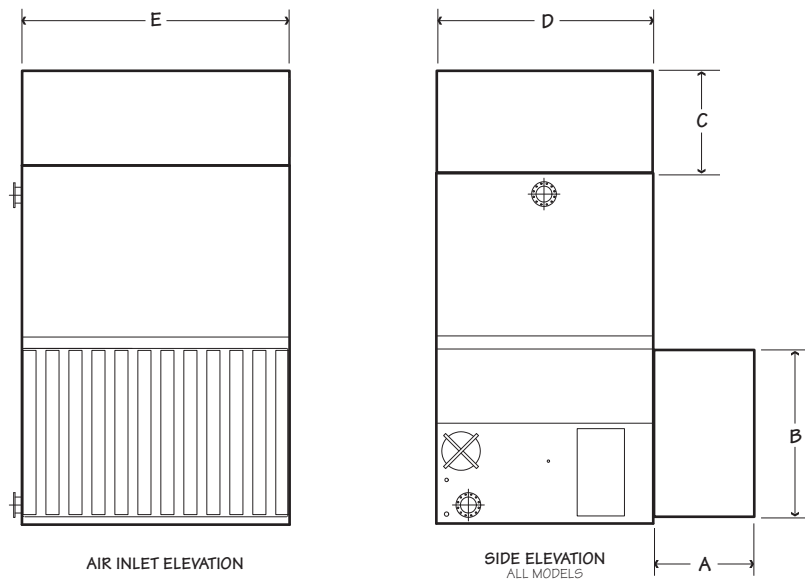

Model	Dimensions				
	A	B	C	D	E
90111	1100	1113	1125	1250	912
	1700	1113	1725	1250	912
90112	1100	1113	1125	1250	1824
	1700	1113	1725	1250	1824
90113	1100	1113	1125	1250	2736
	1700	1113	1725	1250	2736
90114	1100	1113	1125	1250	3648
	1700	1113	1725	1250	3648
90115	1100	1113	1125	1250	5472
	1700	1113	1725	1250	5472
90154	1100	2120	1125	2400	3550
	1700	2120	1725	2400	3550
90155	1100	2120	1125	2400	5380
	1700	2120	1725	2400	5380
90173	1100	2120	1125	2960	2680
	1700	2120	1725	2960	2680
90174	1100	2120	1125	2960	3640
	1700	2120	1725	2960	3640
90175	1100	2120	1125	2960	5360
	1700	2120	1725	2960	5360
90194	1100	2120	1125	3600	3550
	1700	2120	1725	3600	3550
90195	1100	2120	1125	3600	5360
	1700	2120	1725	3600	5360

NOTE

1 Attenuators will result in an additional external resistance therefore the fan will be unable to deliver the same airflow resulting in a small reduction in performance.

2 Critical noise applications **must** be referred to SPX Cooling Tech engineering.

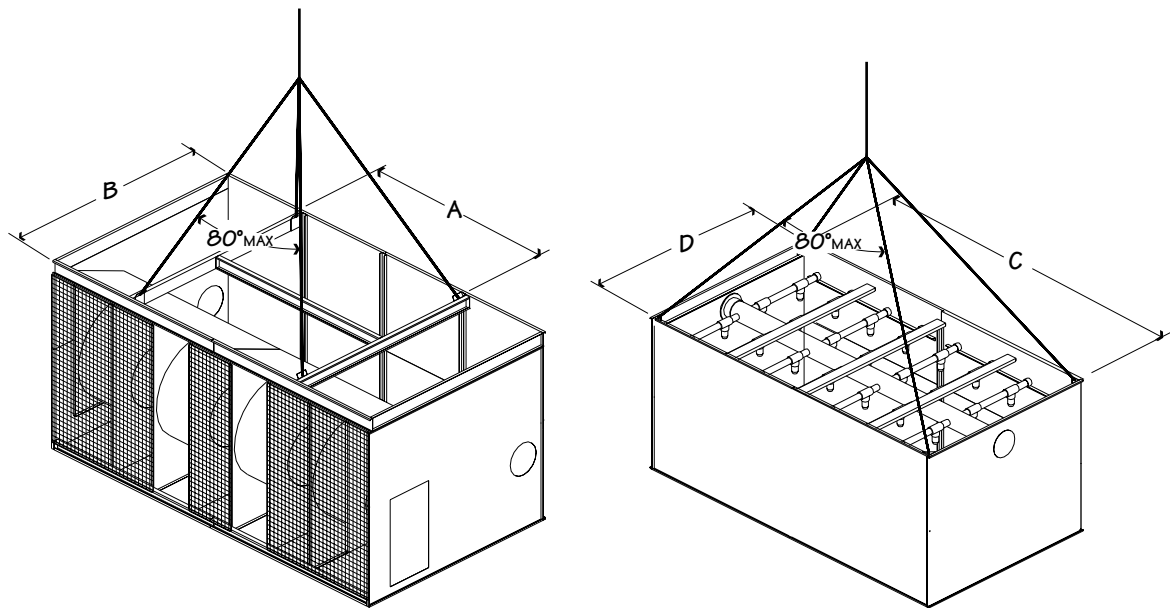

Model	Lower Module			Upper Module		
	A	B	Weight kg	C	D	Weight kg
90111	510	1250	240	920	1250	335
90112	1420	1250	380	1834	1250	455
90113	2340	1250	515	2746	1250	575
90114	3300	1250	655	3658	1250	695
90115	2690	1250	930	5482	1250	935
90154	1245	2400	1820	3550	2400	1265
90155	3075	2400	2417	5380	2400	1700
90173	2515	2980	1634	2680	2960	1220
90174	1295	2980	2176	3680	2960	1465
90175	2745	2980	2838	5360	2960	2130
90194	1245	3600	2227	3550	3600	1670
90195	3075	3600	2965	5380	3600	2615

NOTE

- 1 Hoisting operations can be dangerous and suitable safety precautions should be taken to protect personnel and the equipment being hoisted.
- 2 All hoisting equipment should be certified and comply with local and national safety regulations.
- 3 Ensure that slings are of sufficient length so not to impose bending loads onto the casing—use of spreader bars is essential.
- 4 For overhead lifts or where additional safety is required, add slings beneath the tower unit

When the ambient air temperature falls below 0°C, the water in a cooling tower can freeze. *Marley Technical Report #H-003 “Operating Cooling Towers in Freezing Weather”* describes how to prevent freezing during operation. Available at spxcooling.com or ask your Marley sales representative for a copy.

During shutdown, water collects in the cold water basin and may freeze solid. You can prevent freezing by adding heat to the water left in the tower—or, you can drain the tower and all exposed pipework at shutdown.

ELECTRIC BASIN HEATERS

An automatic basin water heater system is available consisting of the following components:

- Stainless steel electric immersion heater(s).
 - Threaded couplings are provided in the side of the collection basin.
- IP56 enclosure containing:
 - Magnetic contactor to energize heater.
 - Transformer to convert power supply to 24 volts for control circuit.
 - Solid state circuit board for temperature and low-water cutoff.Enclosure may be mounted on the side of the tower.
- Control probe in the collection basin to monitor water temperature and level.

Heater components are normally shipped separately for installation by others.

Note: any exposed piping that is still filled with water at shutdown—including the makeup water line—should be electrically traced and insulated (by others).

INDOOR STORAGE TANK

With this type of system, water flows from an indoor tank, through the load system, and back to the tower, where it is cooled. The cooled water flows by gravity from the tower to the tank located in a heated space. At shutdown, all exposed water drains into the tank, where it is safe from freezing.

The amount of water needed to successfully operate the system depends on the tower size and m³/hr and on the volume of water contained in the piping system to and from the tower. You must select a tank large enough to contain those combined volumes—plus a level sufficient to maintain a flooded suction on your pump. Control makeup water according to the level where the tank stabilizes during operation.

The MCW cooling tower can be a very effective air washer. Atmospheric dust able to pass through the relatively small louver openings will enter the recirculating water system. Increased concentrations can intensify systems maintenance by clogging screens and strainers—and smaller particulates can coat system heat transfer surfaces. In areas of low flow velocity—such as the collection basin—sedimentary deposits can provide a breeding ground for bacteria.

In areas prone to dust and sedimentation, you should consider installing some means for keeping the collection basin clean. Typical devices include side stream filters and a variety of filtration media.

BLOWDOWN

Blowdown or Bleedoff is the continuous removal of a small portion of the water from the open recirculating system. Blowdown is used to prevent the dissolved solids from concentrating to the point where they will form scale. The amount of blowdown required depends on the cooling range—the difference between the hot and cold water temperatures of the closed circuit— and the composition of the makeup water.

WATER TREATMENT

To control the buildup of dissolved solids resulting from water evaporation, as well as airborne impurities and biological contaminants including Legionella, an effective consistent water treatment program is required. Simple blowdown may be adequate to control corrosion and scale, but biological contamination can only be controlled with biocides.

An acceptable water treatment program must be compatible with the variety of materials incorporated in a cooling tower—ideally the pH of the recirculating water should fall between 6.5 and 9.0. Batch feeding of the chemicals directly into the cooling tower is not a good practice since localized damage to the cooling tower is possible. Specific startup instructions and additional water quality recommendations can be found in the *MCW Cooling Tower User Manual* which accompanies the cooling tower and also is available from your local Marley sales representative.

▲ CAUTION

The cooling tower must be located at such distance and direction to avoid the possibility of contaminated discharge air being drawn into building fresh air intake ducts. The purchaser should obtain the services of a Licensed Professional Engineer or Registered Architect to certify that the location of the fluid cooler is in compliance with applicable air pollution, fire and clean air codes.

Specifications	Specification Value
<p>1.0 Base:</p> <p>1.1 Furnish and install a forced-draft, counterflow-type, factory assembled, film fill, industrial duty, galvanized steel, cooling tower. Unit shall consist of ____ cell(s), as shown on plans. The limiting overall dimensions of the tower shall be ____ wide, ____ long, and ____ high. Total operating kW of all fans shall not exceed ____ kW, consisting of ____ @ ____ kW motor(s). Tower shall be similar and equal in all respects to Marley Model _____.</p> <p>2.0 Thermal Performance:</p> <p>2.1 The tower shall be capable of cooling ____ m3/hr of water from ____ °C to ____ °C at a design entering air wet-bulb temperature of ____ °C. The thermal performance rating shall be Certified by the Cooling Technology Institute.</p> <p>3.0 Performance Warranty:</p> <p>3.1 CTI Certification notwithstanding, the cooling tower manufacturer shall guarantee that the cooling tower supplied will meet the specified performance conditions when the tower is installed according to plan. If, because of a suspected thermal performance deficiency, the owner chooses to conduct an on-site thermal performance test under the supervision of a qualified, disinterested third party in accordance with CTI or ASME standards during the first year of operation; and if the tower fails to perform within the limits of test tolerance; then the cooling tower manufacturer will pay for the cost of the test and will make such corrections as are appropriate and agreeable to the owner to compensate for the performance deficiency.</p> <p>4.0 Design Loading:</p> <p>4.1 The tower and its components shall be</p>	<ul style="list-style-type: none"> ■ Your specification base establishes the type, configuration, base material, and physical limitations of the cooling tower to be quoted. During the planning and layout stages of your project, you will have focused your attention on a cooling tower selection that fits your space allotment, and whose power usage is acceptable. Limitations on physical size and total operating kW avoid the introduction of unforeseen operational and site-related influences. Specifying the number of cells, and the maximum fan kW/cell will work to your advantage. <p>The benefit of a forced-draft counterflow cooling tower is that they are inherently easy to operate, access, and maintain. Forced-draft counterflow towers have all mechanical equipment located at low level for easy access, and the water distribution system is accessible by simply removing the lightweight drift eliminator panels or fill access doors.</p> <ul style="list-style-type: none"> ■ Certification means that the cooling tower has been tested under operating conditions and found to perform as rated by the manufacturer under those circumstances. It assures the buyer that the tower is not intentionally or inadvertently undersized by the manufacturer. <div style="text-align: center; margin: 10px 0;">  </div> <ul style="list-style-type: none"> ■ Certification alone is not sufficient to assure you that the cooling tower will perform satisfactorily in your situation. Certification is established under relatively controlled conditions, and cooling towers seldom operate under such ideal circumstances. They are affected by nearby structures, machinery, enclosures, effluent from other sources, etc. Responsible and knowledgeable bidders will take such site-specific effects into consideration in selecting the cooling tower—but the specifier must insist by the written specification that the designer/manufacturer guarantee this “real world” performance. Any reluctance on the part of the bidder should cause you some concern.

Specifications	Specification Value
<p>designed to withstand a wind load of 1.44 kPa as well as .3g seismic load. The cooling tower shall be designed to withstand shipping and hoisting loads of 2g horizontal or 3g vertical. Handrails, where specified shall be capable of withstanding a 890 N concentrated live load in any direction and shall be designed in accordance with OSHA guidelines.</p>	<ul style="list-style-type: none"> ■ The indicated design values are the minimum allowables under accepted design standards. They give you assurance that the cooling tower can be shipped, handled, hoisted—and ultimately operated in a normal cooling tower environment. Most MCW Series models will withstand significantly higher wind and seismic loads. If your geographic location dictates higher wind load or seismic load values, please make the appropriate changes, after discussion with your Marley sales representative.
<p>5.0 Construction:</p>	
<p>5.1 Except where otherwise specified, all components of the cooling tower shall be fabricated of heavy-gauge steel, protected against corrosion by Z725 galvanizing. After passivation of the galvanized steel (8 weeks at pH 7-8, and calcium hardness and alkalinity at mg/L each), the cooling tower shall be capable of withstanding water having a pH of 6.5 to 9.0; a chloride content up to 500 mg/L as NaCl (300 mg/L as Cl-); a sulfate content (as SO4) up to 200 mg/L; a calcium content (as CaCO3) up to 500 mg/L; silica (as SiO2) up to 150 mg/L; and design operating ranges up to 10°C The circulating water shall contain no oil, grease, fatty acids, or organic solvents.</p>	<ul style="list-style-type: none"> ■ In the history of cooling towers, no other coating for carbon steel has exhibited the success and longevity of galvanization in exposure to the normal cooling tower water quality defined at left. No paints or electrostatically-applied coatings, however exotic they may be, can approach galvanization's history of success. <p>If extended longevity of the cooling tower is required—or unusually harsh operating conditions are expected—consider specifying stainless steel as either the base construction material, or the material utilized for specific components of your choice. See Stainless Steel Options on page 16.</p>
<p>5.2 The specifications, as written, are intended to indicate those materials that will be capable of withstanding the above water quality in continuing service, as well as the loads described in paragraph 4.1. They are to be regarded as minimum requirements. Where component materials unique to individual tower designs are not specified, the manufacturers shall take the above water quality and load carrying capabilities into account in the selection of their materials of manufacture.</p>	
<p>6.0 Mechanical Equipment:</p>	
<p>6.1 Fan(s) shall be forward curved centrifugal-type, which are statically and dynamically balanced. The fan impeller is manufactured from galvanized steel, blades are riveted to the center plate and inlet rings and have stay rods to ensure maximum concentricity and rigidity. The stay rods are adjusted by the manufacturer during the balancing operation and require no field adjustment. Fan(s) shall be driven through one-piece, multi-groove, V-belt, pulleys, and spherical roller bearings.</p>	<ul style="list-style-type: none"> ■ The Marley drive system features all-aluminum sheaves (pulleys), power band belts, and long-life bearings for dependable service. <p>To reduce cost, some manufacturers may use TEAO motors, whose only source of cooling is the flow of air produced by the cooling tower fan. They are sometimes applied at kW's significantly beyond their nameplate rating.</p>



Specifications	Specification Value
<p>Bearings shall be rated at an L10 life of 50,000 hours, or greater. A hinged motor adjustment plate with threaded tensioning bolts shall be installed to allow correct belt tensioning.</p>	<p>Unless otherwise specified, motor speed will be 1500 RPM, 50 Hertz on standard models. If you prefer the operating flexibility of two-speed operation, please specify two-speed, single-winding motors which offer full and half speeds for maximum energy savings. Incidentally, two speed motors are a far better choice than separate “pony” motors which simply double the problems indicated above.</p>
<p>6.2 Motor(s) shall be ____ kW maximum, Totally Enclosed, 1.0 service factor, variable torque, and specially insulated for cooling tower duty. Speed and electrical characteristics shall be _____ RPM, single-winding, 3 phase, 50 hertz, ____ volts. Motor shall operate in the shaft-horizontal position and nameplate kW shall not be exceeded at design operation</p>	<p>The value of a 5 year mechanical equipment warranty speaks for itself.</p>
<p>6.3 The complete mechanical equipment assembly for each cell shall be supported by a rigid, galvanized steel structural support that resists misalignment between the motor and sheaves. The mechanical equipment assembly shall be warranted against any failure caused by defects in materials and workmanship for no less than five (5) years following the date of tower shipment. This warranty is limited to the fan, fan shaft, bearings, sheaves and mechanical equipment support. The motor, motor components and belt(s) are warranted by their manufacturer.</p>	
<p>7.0 Fill and Drift Eliminators:</p>	<ul style="list-style-type: none"> ■ Fill modules can be removed for inspection and cleaning in accordance with local anti legionella guidelines.
<p>7.1 Fill shall be cross-corrugated, counterflow film type, thermoformed from .38mm thick PVC. Fill shall be assembled into modules for ease of removal and cleaning. Fill shall be supported on galvanized channel sections supported from the tower structure. Drift eliminators shall be PVC, triple pass and shall limit drift losses to 0.005% or less of the design water flow rate.</p>	<p>Drift rate varies with design water loading and air rate, as well as drift eliminator depth and number of directional changes. A drift rate of 0.001% is readily available in standard configuration without premium cost. If a lower rate is required, please discuss with your Marley sales representative.</p>
<p>8.0 Hot Water Distribution System:</p>	<ul style="list-style-type: none"> ■ The combination of PVC piping and polypropylene nozzles is very resistant to the build-up of scale and slime.
<p>8.1 A pressured spray system shall distribute water evenly over the fill. Header and branch arms shall be PVC with polypropylene spray nozzles attached to the branch arms by an integral screw connection for ease of removal and cleaning. A flanged connection on the header shall be provided for attachment to process piping.</p>	
<p>9.0 Casing:</p>	
<p>9.1 The casing shall be heavy-gauge heavy-mill galvanized steel and shall be capable of withstanding the loads described in paragraph 4.1.</p>	

Specifications	Specification Value
<p>10.0 Access:</p> <p>10.1 A large galvanized, rectangular access door shall be located on both end panels for entry into the cold water basin. Rectangular panels are shall be provided for access to the fan plenum area to facilitate inspection and allow maintenance to the fan drive system</p> <p>11.0 Cold Water Collection Basin:</p> <p>11.1 The collection basin shall be heavy-gauge galvanized steel and shall include the number and type of suction connections required to accommodate the out-flow piping system shown on the plans. Suction connections shall be equipped with debris screens. A factory installed, float operated, mechanical make-up valve shall be included. An overflow and drain connection shall be provided in each cell of the tower. The basin floor shall slope toward the drain to allow complete flush out of debris and silt which may accumulate.</p> <p>13.0 Warranty:</p> <p>13.1 The MCW cooling tower shall be free from defects in materials and workmanship for a period of twelve (12) from date of initial use or eighteen (18) months from the date of delivery, whichever comes first.</p> <p><u>Stainless Steel Options</u></p> <p>Stainless Steel Collection Basin:</p> <p>11.1: <i>Replace paragraph 11.1 with the following:</i> The collection basin shall be heavy-gauge Series 300 stainless steel and shall include the number and type of suction connections required to accommodate the out-flow piping system</p>	<p>■ The MCW tower design offers side-suction as standard. Bottom outlets may be supplied to accommodate a variety of piping schemes. Unless so specified, the tower you may be asked to approve may only be available with one type of suction connection requiring you to redesign your piping layout.</p> <p>The sloping floor and low-level drain is valuable because it provides a way to achieve flush-out cleanability.</p>

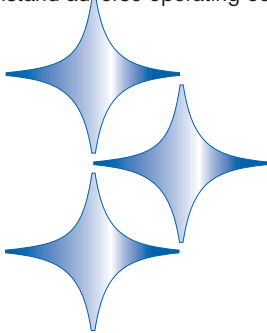
Specifications	Specification Value
<p>shown on the plans. Suction connections shall be equipped with debris screens. A factory installed, float operated, mechanical make-up valve shall be included. An overflow and drain connection shall be provided in each cell of the tower. The basin floor shall slope toward the drain to allow complete flush out of debris and silt which may accumulate.</p> <p>All Stainless Cooling Tower:</p> <p>5.1 <i>Replace paragraph 5.1 with the following:</i> Except where otherwise specified, all components of the cooling tower shall be fabricated of heavy-gauge, series 300 stainless steel. The tower shall be capable of withstanding water having a chloride content (NaCl) up to 750 mg/L; a sulfate content (SO4) up to 1200 mg/L; a calcium content (CaCO3) up to 800 mg/L; silica (SiO2) up to 150 mg/L; and design operating ranges up to 10°C. The circulating water shall contain no oil, grease, fatty acids, or organic solvents.</p> <p>Convenience and Safety Options</p> <p>Top Access Platform:</p> <p>10.2 <i>Add the following paragraph in the Access section:</i> There shall be an access platform at the top of the tower to allow access to the drift eliminators and distribution system. The platform shall be free-standing galvanized steel bar grating, supported by galvanized steel framework. The platform shall be surrounded by a handrail, kneerail, and toeboard designed according to meet local safety requirements. Handrails and kneerails shall consist of 42mm O.D. x 15 gauge galvanized structural tubing, the handrail of which shall be capable of withstanding a 890 N concentrated live load in any direction. Posts are 51mm x 51mm square structural tubing and shall be spaced on centers of 2.44m or less. A ladder shall be permanently attached to the platform and to the casing of the tower, rising from the base of the tower to the top of the handrail.</p> <p>Ladder Extension:</p> <p>10.2 <i>Add the following to the end of paragraph 11.2:</i> Provide a ladder extension for connection to the foot of the ladder. This extension shall be long enough to rise from the roof (grade) level to the</p>	<ul style="list-style-type: none"> ■ The cold water basin is the only part of the tower that is subject to periods of stagnant water, concentrated with treatment chemicals and customary contaminants. It is also the most expensive and difficult part of any tower to repair or replace. For these reasons, many customers—particularly those who are replacing older towers—choose to specify stainless steel cold water basins. ■ For pure resistance to corrosion—coupled with the capability to meet stringent fire and building codes—there is no substitute for stainless steel. No paints or electrostatically-applied coatings, however exotic they may be, can match stainless steel's ability to withstand adverse operating conditions. <div style="text-align: center;">  </div> ■ Periodic inspection and maintenance of a cooling tower distribution system is fundamental to preserving maximum cooling system efficiency. All cooling towers—crossflow or counterflow—are subject to clogging to varying degrees by waterborne contaminants such as pipe scale and sediment. Therefore, safe and easy access to these components is of significant value to the operator. <p>Access can be provided in a number of ways, including portable ladders or scaffolding, but for maximum safety and convenience, a field installed Marley access platform with guardrails is available to make this task as safe and user-friendly as possible. Further, its location on the side of the tower does not add to the height of the unit, preserving architectural integrity. It also saves the owner time and money, in that maintenance personnel may devote their time to inspection rather than searching for ladders or erection of portable scaffolding.</p>

Specifications	Specification Value
<p>base of the cooling tower. The installing contractor shall be responsible for cutting the ladder to length; attaching it to the foot of the cooling tower ladder; and anchoring it at its base.</p> <p>Ladder Safety Cage:</p> <p>10.3 <i>Add the following paragraph in the Access section:</i> A heavy gauge galvanized steel safety cage shall surround the ladder, extending from a point approximately 2150mm above the foot of the ladder to the top of the handrail.</p> <p>Access Door Platform:</p> <p>10.4 <i>Add the following paragraph in the Access section:</i> There shall be an access platform at the base of the tower extending across the width of the casing. The platform shall be galvanized steel bar grating, supported by galvanized steel framework attached to the tower. The platform shall be surrounded by a handrail, kneerail, and toeboard.</p> <p>Distribution System Access Door Platform:</p> <p>10.5 <i>Add the following paragraph in the Access section:</i> There shall be an access platform at the level of the distribution system access door. The platform shall be galvanized steel bar grating, supported by free-standing galvanized steel framework attached to the tower. The platform shall be surrounded by a handrail, kneerail, and toeboard.</p> <p>Control Options</p> <p>Fan Motor Starter Control Panel:</p> <p>6.4 <i>Add the following paragraph in the Mechanical Equipment section:</i> Each cell of the cooling tower shall be equipped with a UL / CUL 508 listed control panel in a IEC IP14 or IP56 outdoor enclosure capable of controlling single-speed or two-speed motors as required, and designed specifically for cooling tower applications. The panel shall include a main circuit breaker or main fused disconnect with an external</p>	<ul style="list-style-type: none"> ■ Many cooling towers are installed such that the base of the unit is 600mm or more above the roof or grade level. This makes it difficult to get up to the foot of the attached ladder. The ladder extension alleviates this problem. Marley ladder extensions are available in standard 1524mm and 3353mm lengths. ■ Where cooling towers are installed on an elevated grillage or piers, it is often difficult to get to—and through—the access door conveniently. This platform provides easy, safe, and comfortable access to that door. ■ This platform provides easy, safe and comfortable access to the access door facilitating inspection of the fill, distribution nozzles and the underside of the drift eliminators

Specifications	Specification Value
----------------	---------------------

operating handle, lockable in the off position for safety. Full voltage non-reversing magnetic starter shall be controlled with a thermostatic or solid-state temperature controller. Door mounted selector switches shall be provided to enable automatic or manual control and wired for 230VAC control. Control circuit to be wired out to terminal blocks for field connection to a remote vibration switch, overload trip alarms and remote temperature control devices. The temperature controller shall be adjustable for the required cold-water temperature. If a thermostatic controller is used it shall be mounted on the side of the tower with the temperature sensing bulb installed in the cold water basin using a suspension mounting bracket. If a solid-state temperature controller is used the controller will be door mounted on the control panel. The solid-state temperature controller will display two temperatures, one for outgoing water and the other for set point. Water temperature input shall be obtained using a three-wire RTD with dry well in the outlet water piping and wired back to the solid-state temperature controller in the control panel.

Vibration Limit Switch:

6.5 *Add the following paragraph in the Mechanical Equipment section:*
 A single-pole, double-throw vibration limit switch in a IP56 housing shall be installed on the mechanical equipment support for wiring into the owner's control panel. The purpose of this switch will be to interrupt power to the motor in the event of excessive vibration. It shall be adjustable for sensitivity, and shall require manual reset.

Basin Heater:

11.2 *Add the following paragraph in the Cold Water Basin section:* Provide a system of electric immersion heaters and controls for each cell of the tower to prevent freezing of water in the collection basin during periods of shutdown. The system shall consist of one or more stainless steel electric immersion heaters installed in threaded couplings provided in the side of the basin. A IP56 enclosure shall house a magnetic contactor to energize heaters; a transformer to provide 24 volt control circuit power; and a solid state circuit board for temperature and low water cut-off. A control probe

- If it is your opinion that the control system for the cooling tower be part of the cooling tower manufacturer's responsibility, we are in wholehearted agreement with you. Who better to determine the most efficient mode and manner of a cooling tower's operation—and to apply a system most compatible with it—than the designer and manufacturer of the cooling tower?

Marley variable speed drives are also available for the ultimate in temperature control, energy management, and mechanical equipment longevity.



- Unless specified otherwise, a IMI Sensors vibration switch will be provided. The requirement for manual reset assures that the cooling tower will be visited to determine the cause of excessive vibration.

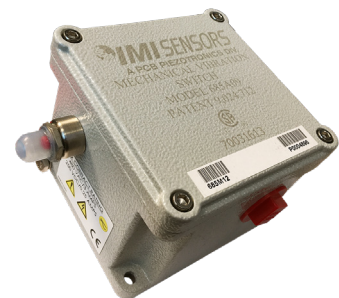

Specifications	Specification Value
<p>shall be located in the basin to monitor water level and temperature. The system shall be capable of maintaining 5°C water temperature at an ambient air temperature of _____°C.</p> <p>Fan Motor Variable Speed Drive:</p> <p>ACH550 VFD System</p> <p>6.4 <i>Add the following paragraph in the Mechanical Equipment section when VFD is used with customers Building Management System:</i> For fan control a complete UL listed variable speed drive system in a IP10 indoor, IP52 indoor or IP54 outdoor enclosure shall be provided. The VFD shall use PWM technology with IGBT switching. VFD output switching signal shall be programmed to not cause mechanical vibration issues with backlash in gearbox teeth or vibration issues associated with long driveshafts. The VFD shall be programmed for variable torque applications and shall catch a fan spinning in the forward or reverse direction without tripping. VFD panel construction shall include a main disconnect with short circuit and thermal overload protection with external operating handle, lockable in the off position for lock-out tag-out safety procedures. A service switch directly ahead of the VFD shall be provided for voltage isolation during VFD maintenance. An integrated full voltage non-reversing bypass starter shall be furnished allowing fan motor operation if VFD has failed. The VFD system shall receive a speed reference signal from the building management system monitoring the cooling tower cold-water temperature. As an option to receiving the speed reference signal from a building management system, the drive must have the capability to receive a 4-20 mA temperature signal from an RTD transmitter. When using an RTD for temperature monitoring and speed control the VFD shall have an internal PI regulator to modulate fan speed maintaining set point temperature. The drive's panel shall display the set-point temperature and cold-water temperature on two separate lines. The bypass shall include a complete electromechanical magnetic bypass circuit with the capability to isolate the VFD when in the bypass mode. Transfer to the bypass mode shall be manual in the event of VFD failure. Once the motor is trans-</p>	<ul style="list-style-type: none"> ■ The Marley basin heater components described at left represent our recommendation for a reliable automatic system for the prevention of basin freezing. They are normally shipped separately for installation at the jobsite by the installing contractor. When purchased in conjunction with the enhanced Control System option, however, they are customarily factory-mounted and tested. <p><i>Submerged in basin water, in which zinc ions are present, copper immersion heaters must not be used. Insist upon stainless steel.</i></p> <p>The ambient air temperature that you insert in the specifications should be the lowest 1% level of winter temperature prevalent at site.</p> <ul style="list-style-type: none"> ■ Marley VFD drive systems are designed to combine absolute temperature control with ideal energy management. The cooling tower user selects a cold water temperature and the drive system will vary the fan speed to maintain that temperature. Precise temperature control is accomplished with far less stress to the mechanical equipment components. The improved energy management provides fast payback.

Specifications	Specification Value
<p>ferred to the bypass circuit the fan motor will run at constant full speed. Operator controls shall be mounted on the front of the enclosure and shall consist of Start and Stop control, Bypass/VFD selection, Auto/Manual selections and manual speed control. To prevent heating problems in the fan motor the VFD system shall de energize the motor once 25% motor speed is reached and cooling is no longer required. The manufacturer shall supply VFD start-up assistance by a certified technician.</p>	
<p>Marley Premium VFD System</p>	
<p>6.4 <i>Add the following paragraph in the Mechanical Equipment section when VFD is used as a stand alone system and not controlled by a BMS:</i> For fan control a complete UL listed variable speed drive system in a IP52 indoor or IP54 outdoor enclosure shall be provided. The VFD shall use PWM technology with IGBT switching. VFD output switching signal shall be programmed as not to cause mechanical vibration issues with back lash in gearbox teeth or vibration issues associated with long drive shafts. VFD shall be programmed for variable torque application. The VFD shall catch a fan spinning in the forward or reverse direction without tripping. VFD panel construction shall include a main disconnect with short circuit and thermal overload protection with external operating handle, lockable in the off position for lock-out tag-out safety procedures. A service switch directly ahead of the VFD shall be provided for voltage isolation during VFD maintenance. An integrated full voltage non-reversing bypass starter shall be furnished allowing fan motor operation if VFD has failed. In the event of a system fault the VFD program logic shall evaluate type of fault determining if safe to automatically transfer fan motor to the bypass starter. Automatic bypass with an earth ground condition shall not be allowed. Once in bypass mode the internal controls will continue to monitor cold water temperature and cycle the fan motor on and off maintaining cold-water set point temperature. The drive system shall be designed and operated as a stand-alone system without the need for a BMS system. Operator controls shall be mounted on the front of the enclosure and shall consist of Start and Stop con-</p>	

Specifications	Specification Value
<p>trol, Bypass/VFD selector switch, Auto/Manual selector switch, Manual speed control, and solid-state temperature controller. An emergency bypass starter selector switch internal to the panel allowing the fan motor to be run at full speed shall be furnished. The system shall include a solid state PI temperature controller to adjust frequency output of the drive in response to the tower cold-water temperature. A four-wire RTD with dry well shall be furnished with the VFD and field installed into the cold-water discharge pipe coming from the fluid cooler cell. The temperature of the cold-water and set point shall be displayed on the door of the control panel. The bypass starter shall be integrated into the same enclosure as the VFD including complete circuitry to isolate the VFD when in the bypass mode. To prevent heating problems in the fan motor the VFD system shall de-energize the motor once 25% motor speed is reached and cooling is no longer required. The manufacturer shall supply VFD start-up assistance by a certified technician.</p> <p>Miscellaneous Options</p> <p>Sound Control:</p> <p>1.2 <i>Add the following paragraph under Base:</i> The cooling tower shall be quiet operation, and shall produce an overall level of sound not higher than _____ dB(A) measured at the critical location indicated on the plans.</p> <p>Premium Efficiency Motor:</p> <p>6.3 <i>Replace paragraph 6.3 with the following: The fan and fan drive assembly for each cell shall be supported by a rigid, welded, hot dip galvanized steel structural support that resists misalignment. The mechanical equipment assembly shall be warranted against any failure caused by defects in materials and workmanship for no less than five (5) years following the date of tower shipment. This warranty shall cover the fan, speed reducer, motor,</i></p>	

Specifications	Specification Value
<p><i>drive shaft and couplings, and the mechanical equipment support. The bearing assemblies and V-belts shall be warranted for 18 months.</i></p>	
<p>Discharge Hood:</p>	
<p><u>6.4</u> <i>Add the following paragraph to the Mechanical Equipment Section: There shall be a galvanized steel tapered duct</i></p>	<p>■ Sound produced by a standard MCW Series tower operating in an unobstructed environment will meet all but the most restrictive noise limitations—and will react favorably to natural attenuation. Where the tower has been sized to operate within an enclosure, the enclosure itself will have a damping effect on sound. Sound also declines with distance—by about 5 or 6 dB(A) each time the distance doubles. Where noise at a critical point is likely to exceed an acceptable limit, you have several options—listed below in ascending order of cost impact:</p> <ul style="list-style-type: none"> • Where only a slight reduction in noise will satisfy—and the source of concern is in a particular direction—merely turning the tower may be the answer. Less sound emanates from the cased face of the tower than does from the air intake face. • In many cases, noise concerns are limited to night time, when ambient noise levels are lower and neighbors are trying to sleep. You can usually resolve these situations by using two speed motors in either full / half speed or full / 2/3 speed configuration, and operating the fans at reduced speed without cycling “after hours”. (The natural night time reduction in wet-bulb temperature makes this a very feasible solution in most areas of the world, but the need to avoid cycling may cause the cold water temperature to vary significantly.) • Variable speed drives automatically minimize the tower’s noise level during periods of reduced load and/or reduced ambient without sacrificing the system’s ability to maintain a constant cold water temperature. This is a relatively inexpensive solution, and can pay for itself quickly in reduced energy costs. • Where noise is a concern at all times (for example, near a hospital), the best solution is to oversize the tower so it can operate continuously at reduced (2/3 or 1/2) motor speed even at the highest design wet-bulb temperature. Typical sound reductions are 7 dB(A) at 2/3 fan speed or 10 dB(A) at 1/2 fan speed, but larger reductions are often possible. • The most extreme cases may require inlet and discharge sound attenuator sections—however, the static pressure loss imposed by discharge attenuators may necessitate an increase in tower size. Two stages of inlet or discharge attenuators supported by the tower and designed and tested for the most stringent requirements are available as an option. See page 18. <p>The advantage is yours. You now have the choices you need to balance your project’s performance, space and cost requirements with your sound level needs for a win-win solution to your cooling system design. Your Marley sales representative will be able to help you meet your sound requirements.</p>

Specifications	Specification Value
<p>on the discharge side of the tower. Drift eliminators shall be repositioned into the lower section of the duct.</p>	<ul style="list-style-type: none"> ■ Where a tower is installed in a building well or there are high surrounding walls it is possible that a proportion of the hot and humid discharge air will be drawn back into the fans thus increasing the inlet wet bulb temperature with detriment to the tower performance. <p>The tapered discharge duct is intended to increase the exit velocity by up to 70% in order to reduce the effects of recirculation in some installations. Experience and sound judgement should be exercised to determine when and if a duct is required.</p> <p>If the surrounding walls are much higher than the tower discharge height then extensions to the tapered duct may be installed.</p> 

SPX COOLING TECHNOLOGIES MALAYSIA SDN BHD

UNIT 505, BLOCK B, PHILEO DAMANSARA 2
NO. 15 JALAN 16/11 OFF JALAN DAMANSARA
46350 PETALING JAYA, MALAYSIA
60 3 7947 7800 | th.my.enquiry@spx.com
spxcooling.com

sea_MCW-TS-24 | ISSUED 3/2024

©2006-2024 SPX COOLING TECH, LLC | ALL RIGHTS RESERVED

In the interest of technological progress, all products are subject to design a
nd/or material change without notice.

SPX 
TECHNOLOGIES