

# Quadraflow<sup>®</sup> cooling tower

INSTALLATION - OPERATION - MAINTENANCE

sea\_Z0238885\_D ISSUED 8/2018

READ AND UNDERSTAND THIS MANUAL PRIOR TO OPERATING OR SERVICING THIS PRODUCT.

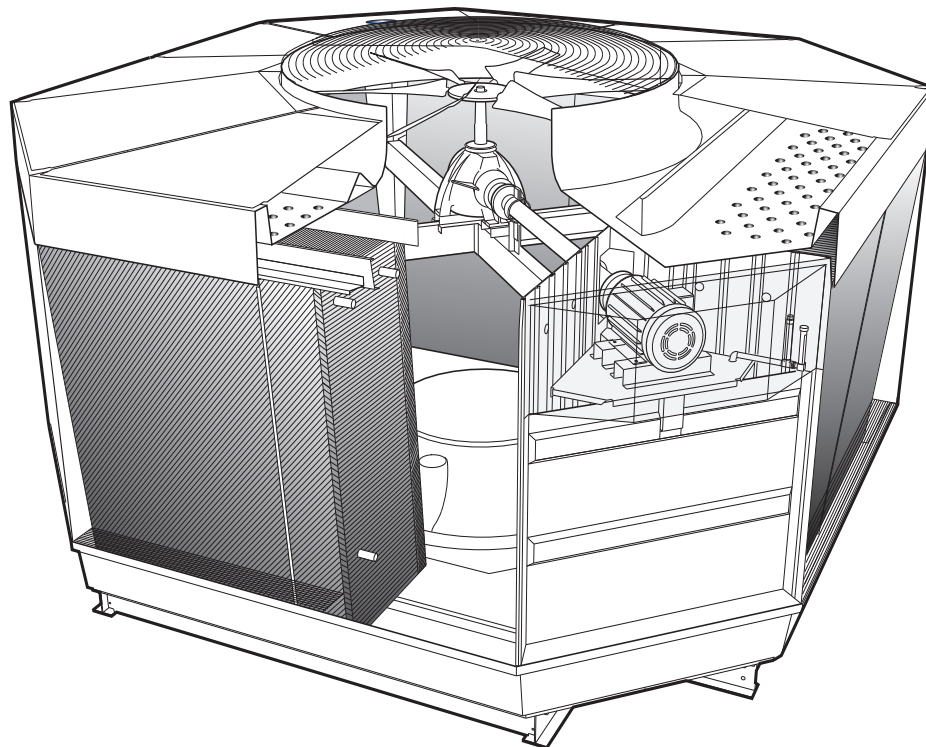

---

## contents

---

### Note

***This manual contains vital information for the proper installation and operation of your cooling tower. Carefully read the manual before installation or operation of the tower and follow all instructions. Save this manual for future reference.***

Overview .....	3
Tower Location .....	3
Tower Shipment.....	4
Receiving Tower .....	4
Tower Assembly .....	4
Motor Wiring .....	4
Tower Startup .....	9
Freezing Weather Operation.....	10
Tower Maintenance.....	13
Water Quality and Blowdown.....	13
Schedule of Tower Maintenance .....	15
Seasonal Shutdown Instructions .....	18
Motor Relubrication Instructions .....	19
Prolonged Shutdown .....	19
Additional Services.....	20
Additional Information .....	21
Troubleshooting.....	22

The following defined terms are used throughout this manual to bring attention to the presence of hazards of various risk levels, or to important information concerning the life of the product.

---

### ⚠ Warning

***Indicates presence of a hazard which can cause severe personal injury, death or substantial property damage if ignored.***

---

### ⚠ Caution

***Indicates presence of a hazard which will or can cause personal injury or property damage if ignored.***

---

### Note

***Indicates special instructions on installation, operation or maintenance which are important but not related to personal injury hazards.***

---

## overview

This User Manual as well as those offered separately on motors, fans, Geareducer, couplings, drive shafts, float valves, pumps, etc., are intended to assure that this cooling tower serves you properly for the maximum possible time. Since product warrantability may well depend upon your actions, please read this User Manual thoroughly prior to operation.

This User Manual provides information regarding general cooling tower installation and operation. Any deviation from, change or modification to, the User Manual, the original design conditions or the original intended use of the equipment may result in improper installation and/or operation of the tower.

Any such deviation, change or modification shall be the responsibility of the party or parties making such deviation, change or modification. SPX Cooling Technologies, Inc. expressly disclaims all liability for any such deviation, change or modification. The equipment shall be warranted in accordance with the applicable SPX Cooling Technologies Certification of Limited Warranty.

If you have questions about the operation and/or maintenance of this cooling tower, and you don't find the answers in this manual, please contact your Marley sales representative. When writing for information, or when ordering parts, please include the serial number shown on the cooling tower nameplate.

---

### Tower Location

Space available around the tower should be as generous as possible to promote ease of maintenance—and to permit freedom of airflow into and through the tower. If you have questions about the adequacy of the available space and the intended configuration of the tower, please contact your Marley sales engineer for guidance.

Prepare a stable, level support foundation for the tower, utilizing weight, wind load, and dimensional information appearing on appropriate Marley submittal drawings. Supports must be level to insure proper operation of the tower.

---

#### **⚠ Warning**

***The cooling tower must be located at such distance and direction to avoid the possibility of contaminated tower discharge air being drawn into building fresh air intake ducts. The purchaser should obtain the services of a Licensed Professional Engineer or Registered Architect to certify that the location of the tower is in compliance with applicable air pollution, fire, and clean air codes.***

---

# installation

---

## **Tower Shipment**

QuadraFlow towers ship by truck (on flat bed trailers) in an unassembled condition. Single cell towers ship on one truck. Multicell towers, depending on their size, may require more than one truck. Responsibility for the condition of the tower upon its arrival belongs to the trucker—as does the coordination of multiple shipments, if required.

---

## **Receiving Tower**

Prior to unloading the tower from the delivering carrier, inspect the shipment for evidence of damage in shipment. If damage is apparent, note the freight bill accordingly. This will support your future recovery claim.

---

## **Tower Assembly**

Your Marley sales representative is able to provide for the tower assembly by SPX's construction division or through a qualified subcontractor. Our subcontractors provide safe, efficient assembly which complies with all requirements for five-year warranty protection of your tower by SPX.

---

## **Motor Wiring**

Wire motor leads as shown on the motor nameplate matching the supply voltage. Do not deviate from the motor nameplate wiring.

Internal space heaters may be present, depending upon the motor manufacturer. For space heater operation and wiring refer to the Marley **"Fan Motor"** User Manual Z0239042.

Either of following symbols may be shown on the motor nameplate –  $\Delta$ ,  $\Delta \Delta$ , Y, or YY. These symbols represent how the motor is constructed on the inside and in no way have anything to do with a Delta or Wye electrical distribution system serving the motor.

### **When using a starter:**

- Set motor overload protection to 110% of motor nameplate amps. This setting allows the fan motor to operate during cooler weather. During cools are common during tower commissioning when the tower is dry and the ambient air temperature is cool.

---

## installation

---

### Note

***Do not start the motor more than four to five times per hour. Short cycling the tower will cause fuses, breakers or O.L.s to operate and will decrease motor life.***

**When using a two-speed starter:**

- Motor rotation must be the same at slow speed and high speed.
- Single winding motor requires a starter with a shorting contactor.
- Two-winding motor requires a starter with out a shorting contactor.
- All two-speed starters must have a 20 second time delay relay when switching from high speed to low speed.

---

### Note

***Do not start the motor more than four to five times per hour (each low speed start and each high speed start count as one start).***

**When using a VFD:**

---

### Note

***Before beginning, ensure that the motor is rated for “Inverter Duty” per NEMA MG-1, part 31.***

- Set the VFD solid state overload protection to 119% of motor nameplate amps and set “maximum current parameter” in the VFD to motor nameplate amps. “Maximum current parameter” will reduce fan speed and limit amp draw to nameplate amps during cold weather operation. If furnished with a mechanical O.L. set this at 110% over motor nameplate amps.
- Motor rotation must be the same in both VFD mode and By-pass mode.
- If cable distance between the VFD and motor is greater than 30 meters a DV/DT output filter is recommended to avoid damage to the motor. 30 meters distance is based on our field experience, the VFD manufacture may state different distances and distance does vary depending on the VFD manufacture.
- Program the VFD for variable torque output. Flux vector and constant torque modes may damage the gearbox.
- Do not start and stop the motor using the safety switch at the motor. If the drive is being commanded to run and the load side is cycled ON and OFF with the safety switch this may damage the VFD.

Using a VFD in cooling applications has advantages over traditional single or two speed motor control. A VFD can reduce the cost of electrical energy being used and provide better temperature control. In addition, it reduces the mechanical and electrical stress on the motor and mechanical equipment.



---

## installation

Electrical savings can be large during periods of low ambient temperature when the cooling requirement can be satisfied at reduced speeds. To benefit from these advantages, it is important that the drive be installed correctly.

Marley supplies VFD and VFD controls specifically designed for our cooling products. If you have purchased a Marley VFD and/or controls package, please follow the instructions in the *User Manual* for that system. Most VFD problems can be avoided by purchasing the Marley drive system. If you are installing a VFD other than the Marley drive, please refer to that drives installation manual.

---

### ⚠ Warning

***Improper use of a VFD may cause damage to equipment or personal injury. Failure to correctly install the VFD drive will automatically void all warranties associated with the motor and any equipment that is either electrically or mechanically (directly) attached to the VFD drive system. The length of this warranty avoidance will be contingent on properly installing the VFD system and repairing any damage that may have occurred during its operation. SPX Cooling Technologies does not assume responsibility for any technical support or damages for problems associate with non-Marley brand VFD systems.***

---

### ⚠ Warning

***Changing the operational fan speed from the factory settings could cause the fan to operate in an unstable region which may result in damage to the equipment and possible injury.***

### **Mechanical Equipment:**

---

### ⚠ Warning

***Always make certain that mechanical equipment is inoperable during periods of maintenance—or during any situation of possible endangerment to personnel. If your electrical system contains a disconnect switch, lock it out until the period of exposure to injury is over.***

1. Check the Geareducer oil level at the sight glass near the motor. If oil is required, fill to the proper level.
2. Spin the fan manually to assure that all fan blades properly clear the inside of the fan cylinder. Observe the action of the driveshaft couplings to be sure that the motor and Geareducer are properly aligned. If necessary, correct the alignment in accordance with the included driveshaft manual.
3. Momentarily energize (“bump”) the motor and observe rotation of the fan. The fan should rotate in a counterclockwise direction when viewed from below. If rotation is backwards, shut off the fan and reverse two of the three primary leads supplying power to the motor.

---

## installation

---

### ⚠ Caution

***If tower is equipped with a two-speed motor, check for proper rotation at both speeds. Check also to see that starter is equipped with a 20-second time delay which prevents direct switching from high speed to low speed. This delay will allow the fan to slow down and will prevent abnormal stress from being applied to the mechanical equipment and the electrical circuit components.***

4. Run the motor and observe the operation of the mechanical equipment. Operation should be stable, and there should be no evidence of oil leakage.

---

### Note

***If the water supply system is not being operated—or if there is no heat load on the system—motor amps read at this time may indicate an apparent overload of as much as 10–20%. This is because of the increased density of unheated air flowing through the fan. Determination of an accurate motor load should await the application of the design heat load.***

### General:

The cold water temperature obtained from an operating cooling tower will vary with the following influences:

1. **Heat Load** With the fan in full operation, if the heat load increases, the cold water temperature will rise. If the heat load reduces, the cold water temperature will reduce.

Note that the number of degrees (“range”) through which the tower cools the water is established by the system heat load and the amount of water being circulated, in accordance with the following formula:

$$\text{Range (}^{\circ}\text{C)} = \frac{\text{Heat Load (kW)}}{\text{Water Flow (m}^3\text{/h)} \times 1.162}$$

The cooling tower establishes only the cold water temperature attainable under any operating circumstance.

2. **Air Wet-Bulb Temperature** Cold water temperature will also vary with the wet-bulb temperature of the air entering the louvered faces of the tower. Reduced wet-bulb temperatures will result in colder water temperatures. However, the cold water temperature will not vary to the same extent as the wet-bulb. For example, an 11°C reduction in wet-bulb may result in only an 8°C reduction in cold water temperature.



---

## installation

3. **Water Flow Rate** Increasing the water flow rate ( $\text{m}^3/\text{h}$ ) will cause a slight elevation in cold water temperature, while reducing the water flow rate will cause the cold water temperature to lower slightly. However, at a given heat load (see formula above),  $\text{m}^3/\text{h}$  reductions also cause an increase in the incoming hot water temperature. Use care to prevent the hot water from exceeding  $52^\circ\text{C}$ , in order to prevent damage to the tower components.
4. **Airflow Rate** Reducing airflow through the tower causes the cold water temperature to rise. This is the approved method by which to control leaving water temperature.

If your tower is equipped with a single-speed motor, the motor may be shut off when the water temperature becomes too cold. This will cause the water temperature to rise. When the water temperature then becomes too warm for your process, the motor can be restarted.

### Fan cycling limits:

---

#### Note

***Considering the normal fan and motor sizes utilized on Quadraflow towers, anticipate that approximately 4 to 5 starts per hour are allowable.***

If your tower is equipped with a two-speed motor, greater opportunity for temperature control is afforded you. When the water temperature becomes too cold, switching the fan to half-speed will cause the cold water temperature to rise—stabilizing at a temperature a few degrees higher than before. With a further reduction in water temperature, the fan may be cycled alternately from half-speed to off.

---

#### Note

***Do not start the motor more than four to five times per hour (each low speed start and each high speed start count as one start).***

If your tower consists of two or more cells, cycling of motors may be shared between cells, increasing your steps of operation accordingly. For greater insight on cold water temperature control, please read *Marley Technical Report #H-001-A*, “**Cooling Tower Energy and its Management**” available for download at [spxcooling.com](http://spxcooling.com).



---

## operation

---

### Warning

---

#### Tower Startup

***Microorganisms including Legionella bacteria can exist in premise plumbing including cooling towers. The development of an effective water management plan (WMP) and implementation of maintenance procedures are essential to prevent the presence, dissemination and amplification of Legionella bacteria and other waterborne contaminants throughout premise plumbing. Before operating the cooling tower, the water management plan and maintenance procedures must be in place and regularly practiced.***

#### Water System:

1. Consult a knowledgeable water treatment professional to clean and treat your new cooling tower prior to startup. Cooling towers must be cleaned and disinfected regularly in accordance with ASHRAE Standard 188 and Guideline 12.
2. Do NOT attempt any service unless the fan motor is locked out.
3. Remove any and all accumulated debris from tower. Pay particular attention to inside areas of cold water basin, entire hot water basin, and hot water inlet. Make sure that cold water suction screens are clear and installed in place.
4. Fill the water system to an approximate depth of 76mm in the elevated section of the cold water basin. This is the recommended operating water level. Adjust the float valve so that it is essentially closed at that level. Continue filling the system until the water reaches a level approximately 3mm **below the lip of the overflow**.
5. Start your pump(s). Observe system operation. Since the water system external to the tower will have been filled only to the level achieved in the cold water basin, a certain amount of “pump-down” of the basin water level will occur before water completes the circuit and begins to fall from the fill. The amount of initial pump-down may be insufficient to cause the float valve to open. However, you can check its operation by pressing down on the operating lever to which the stem of the float valve is attached.
6. Continue pump operation for about 15 minutes, after which it is recommended that the water system be drained, flushed, and refilled in order to clean the system.

---

## operation

7. While operating the condensing water pump(s) and prior to operating the cooling tower fan, execute one of the two alternative biocidal treatment programs described in the following:
  - Resume treatment with the biocide which had been used prior to shut-down. Utilize the services of the water treatment supplier. Maintain the maximum recommended biocide residual (for the specific biocide) for a sufficient period of time (residual and time will vary with the biocide) to bring the system under good biological control
  - or**
  - Treat the system with sodium hypochlorite to a level of 4 to 5 mg/L free chlorine residual at a pH of 7.0 to 7.6. The chlorine residual must be held at 4 to 5 mg/L for six hours, measurable with standard commercial water test kits.

If the cooling tower has been in operation and then shut down for a duration of time and not drained, perform one of the two previous biocidal treatment programs directly to the cooling water storage vessel (cooling tower sump, drain down tank, etc.) without circulating stagnant water over the cooling tower fill or operating the cooling tower fan.

After biocidal pretreatment has been successfully completed, cooling water may be circulated over the tower fill with the fan off.

When biocidal treatment has been maintained at a satisfactory level for at least six hours, the fan may be turned on and the system returned to service. Resume the standard water treatment program, including biocidal treatment.

---

### Freezing Weather Operation

The Marley fill system used in the Quadraflow has air entrance louvers that are molded as an integral part of the fill. This feature makes these towers very forgiving of cold weather operation, even at the low temperature and reduced load conditions encountered in free cooling and other low temperature applications. Nevertheless, during operation in subfreezing weather the opportunity exists for ice to form in the colder regions of the tower.

---

#### Note

***Slushy, transitory ice forms routinely in the colder regions of the fill of low temperature towers, and is visible through the tower louvers. Such ice normally has no adverse effect on tower operation, but its appearance should be a signal to the operator to undertake ice control procedures.***

---

## operation

---

### ⚠ Caution

***It is the operator's responsibility to prevent the formation of destructive (hard) ice on the cooling tower fill. Certain guidelines should be followed:***

1. Do not allow the tower's leaving water temperature to drop below a minimum allowable level—say 2°C to 5°C. If such low temperature operation is necessary or beneficial to your process, establish the minimum allowable level as follows:

During the coldest days of the first winter of operation, observe whether any ice is forming on the louver face, particularly near the bottom part of the louver face. If hard ice is present on the louvers, you must increase the allowable cold water temperature. If the coldest possible water is beneficial to your process, ice of a mushy consistency can be tolerated—but routine periodic observation is advisable.

---

### ⚠ Caution

***If the minimum allowable cold water temperature is established at or near minimum heat load, it should be safe for all operating conditions.***

Having established the minimum allowable cold water temperature, maintaining that temperature can be accomplished by fan manipulation, as outlined in **Item 4** on page 8. However, in towers of more than one cell, where fans are manipulated sequentially, please realize that the water temperature will be significantly lower in the cell or cells operating at the highest fan speed than the net cold water temperature produced by the entire tower would indicate. Wintertime operation of multicell towers at low cold water temperature levels requires that the operator be especially watchful.

2. As cold air enters the louvers, it causes the water flowing over the fill to be drawn inward toward the center of the tower. Thus, under fan operation, the louvers and lower periphery of the tower structure remain partly dry, seeing only random splashing from within the tower—plus normal atmospheric moisture from the entering air. Such lightly wetted areas are most subject to freezing.

Therefore, if excessive ice forms on the louvers, stop the fan for a few minutes. With the fan off, the water flow will increase in the vicinity of the louvers and reduce the ice buildup.

3. Under extended extreme cold conditions, it may be necessary to operate the fan in reverse. This forces warm air out through the louvers, melting any accumulated ice—adequate heat load must be available. Reversal of fan should only be done at **half speed** or less. Reverse operation of



---

## operation

the fan should be used sparingly and should only be used to control ice, **not** to prevent it. Reverse fan operation should not need to exceed 1 or 2 minutes. Monitoring is required to determine the time required to melt accumulated ice.

---

### **⚠ Warning**

***Operating the fan in reverse at half speed for prolonged periods during subfreezing weather can cause severe damage to fans and fan cylinders. Ice can accumulate inside fan cylinders at fan blade plane of rotation and fan blade tips will eventually strike this ring of ice, damaging the fan blades or cylinder. Ice can also accumulate on fan blades and be thrown off, damaging fan cylinder or blades. Allow a minimum of 10 minute delay between reverse operation and forward operation during subfreezing weather to permit ice to dissipate from fan blades and fan cylinders. See Fan Drive Caution Note in the Mechanical Equipment Installation section of this manual.***

4. With no heat load on the circulating water, icing cannot be controlled effectively by air control during freezing weather. **Towers must not be operated with reduced water rate and/or no heat load during freezing weather.** If the circulating water system cannot be shut down, water returning from the process should be made to bypass the tower. If a bypass is used, **all** water must be bypassed without modulation. If the water bypass is directly into the tower's cold water basin, its design must be approved by SPX Cooling Technologies.

### **Intermittent Wintertime Operation:**

If periods of shutdown (nights, weekends, etc.) occur during freezing weather, measures must be taken to prevent the water in the cold water basin –and all exposed pipework–from freezing. Several methods are used to combat this, including automatic basin heater systems available from Marley. It is recommended that you discuss your freeze prevention options with your local Marley sales representative.

---

### **⚠ Caution**

***Unless some means of freeze prevention is incorporated into your system, the tower basin and exposed pipework should be drained at the beginning of each wintertime shutdown period.***

---

### **⚠ Warning**

***If tower basin is drained, verify that all basin heaters have been shut off either by automatic cutoff or disconnect switch.***

---

# maintenance

---

## Water Quality and Blowdown

### Maintaining Water Quality:

The materials used in the QuadraFlow tower are selected to offer long, corrosion-free service in a “normal” cooling tower environment, defined as follows:

- Circulating water with a pH between 6 and 8; a chloride content (as NaCl) below 750 mg/L; a sulfate content (SO<sub>4</sub>) below 1200 mg/L; a maximum inlet water temperature not to exceed 52°C; no significant contamination with unusual chemicals or foreign substances; and adequate water treatment to minimize scaling.
- Chlorine (if used) shall be added intermittently, with a free residual not to exceed 1 mg/L – maintained for short periods. Excessive chlorine levels may deteriorate sealants and other materials of construction.
- An atmosphere surrounding the tower no worse than “moderate industrial,” where rainfall and fog are no more than slightly acid, and they do not contain significant chlorides or hydrogen sulfide (H<sub>2</sub>S).

### Blowdown:

A cooling tower cools water by continuously causing a portion of it to evaporate. Although the water lost by evaporation is replenished by the makeup system, it exits the tower as pure water—leaving behind its burden of dissolved solids to concentrate in the remaining water. Given no means of control, this increasing concentration of contaminants can reach a very high level.

In order to achieve water quality which is acceptable to the cooling tower (as well as the remainder of your circulating water system), the selected water treatment company must work from a relatively constant level of concentrations. This stabilization of contaminant concentrations is usually accomplished by blowdown, which is the constant discharge of a portion of the circulating water to waste. As a rule, acceptable levels on which to base a treatment schedule will be in the range of 2-4 concentrations. The following table gives approximate rates of blowdown (percent of total water flow rate constantly wasted) to achieve those concentrations at various cooling ranges.\*

Cooling Range (°C)	Blowdown Rate	
	Two Concentrations	Four Concentrations
6	0.7%	0.17%
8	1.1%	0.30%
11	1.5%	0.43%

\*Range = Difference between hot water temperature entering the tower and cold water temperature leaving the tower.

---

## maintenance

---

### Note

***When water treatment chemicals are added, they should not be introduced into the circulating water system via the cold water basin of the cooling tower. Water velocities are lowest at that point, which results in inadequate mixing.***

---

### Cooling Tower Inspection and Maintenance

---

#### ⚠ Warning

***Microorganisms including Legionella bacteria can exist in premise plumbing including cooling towers. The development of an effective water management plan (WMP) and implementation of maintenance procedures are essential to prevent the presence, dissemination and amplification of Legionella bacteria and other waterborne contaminants throughout premise plumbing. Before operating the cooling tower, the water management plan and maintenance procedures must be in place and regularly practiced.***

In addition, the following steps are recommended:

Do NOT attempt any service unless the fan motor is locked out.

- Consult a knowledgeable water treatment professional to clean and treat your cooling tower. See **Tower Startup** section of this manual.
- Cooling towers must be cleaned and disinfected regularly in accordance with ASHRAE Standard 188 and Guideline 12.
- Workers performing decontamination procedures must wear personal protective equipment (PPE) as directed by their facility safety officer.
- Cooling towers must be visually inspected regularly to assess signs of bacterial growth, appearance of debris and scale on drift eliminators and general operating conditions. Refer to ASHRAE Standard 188 and Guideline 12 for specific frequency recommendations.
- Replace worn or damaged components.

To minimize the presence of waterborne microorganisms, including Legionella, follow the water management plan for your facility, perform regularly scheduled cooling tower inspections and maintenance, and enlist the services of water treatment professionals.

For additional technical support, contact your Marley sales representative.

References:

ashrae.org. Search "ASHRAE Standard 188" and "ASHRAE Guideline 12."  
cdc.gov. Search "Water Management Program."

---

## maintenance

### **Schedule of Tower Maintenance:**

Included with this instruction packet are separate Service Manuals on each major operating component of the tower, and it is recommended that you read them thoroughly. Where discrepancies may exist, the separate Service Manuals will take precedence.

---

#### **⚠ Warning**

***Do not use the top horizontal surface of the tower as a working platform. The tower is designed so that all maintenance can be performed from the exterior and interior of the tower. Do not use the upper basin covers as a walking surface or working platform. Remove basin covers and use portable ladders whenever performing service on the hot water basin. Use of ladder should be in accord with manufacturer's recommendations***

The following is recommended as a minimum routine of scheduled maintenance:

---

#### **⚠ Warning**

***Always shut off electrical power to the tower fan motor prior to performing any inspections that may involve physical contact with the mechanical or electrical equipment in or on the tower. Lock out and tag out any electrical switches to prevent others from turning the power back on. Service personnel must wear proper personal protective clothing and equipment.***

**Weekly** Visually inspect the cooling tower to assess general operating conditions and for signs of microbial growth and appearance of debris, scale and corrosion. Refer to ASHRAE Standard 188 and Guideline 12 for specific frequency recommendations. Consult a knowledgeable water treatment professional to maintain cooling tower hygiene.

**Monthly** (Weekly at Start-up) Observe, touch, and listen to the tower. Become accustomed to its normal appearance, sound, and level of vibration. Abnormal aspects relating to the rotating equipment should be considered reason to shut down the tower until the problem can be located and corrected. Observe operation of the motor, driveshaft, Geareducer and fan. Become familiar with the normal operating temperature of the motor, as well as the sight and sound of all components as a whole.

Check Geareducer oil level. Shut down the unit and allow 5 minutes for the oil level to stabilize. Add oil if required. Check system for leaks if the amount of oil required appears unusual. (If oil is added at the external fill port, allow adequate time for the level to stabilize before reading final level.)



---

## maintenance

Inspect louvers, drift eliminators and basin trash screens and remove any debris or scale which may have accumulated. Replace any damaged or worn out components. Use of high-pressure water may damage the eliminator and louver material.

Observe operation of the float valve. Depress the operating lever to make sure that the valve is operating freely. Inspect the suction screen for plugging. Remove any debris that may have accumulated.

Check for any buildup of silt on the floor of the cold water basin. Mentally note the amount, if any, so future inspections will enable you to determine the rate at which it is forming.

**Semi-Annually** Relubricate motor according to the manufacturer's instructions. See instructions on page 19.

Check to see that all bolts are tight in the fan and mechanical equipment region, including the fan guard. Use torque settings prescribed on the fan nameplate.

---

### Note

**To maintain five-year change intervals, use only oil designed specifically for these Geareducers. If, after five years, turbine-type mineral oil is used, the oil must be changed semiannually. Refer to *Geareducer User Manual* for oil recommendations and further instructions.**

**Annually:** Inspect the tower thoroughly, making maximum use of instructions given in the separate user manuals. Lubricate motor according to the manufacturer's instructions. Refer to the **Motor Lubrication Instructions** on page 19. Fan motors with sealed bearings do not require lubrication maintenance.

---

### Note

***If the motor has sealed bearings, additional lubrication is not required. Refer to the motor nameplate to determine if grease type and amount are specified.***

Check structural bolted connections and tighten as required. Make preventive maintenance repairs as necessary.

**Every 5 Years** Change Geareducer oil. Refer to *Geareducer User Manual* for instructions.



# maintenance schedule

Maintenance Service	Monthly	Semi-annually	Seasonal Startup or Annually
Inspect General Condition and Operation	<b>x</b>		<b>x</b>
<b>Observe Operation of:</b>			
Mechanical—motor, fan and drive mechanism	<b>x</b>		<b>x</b>
Makeup valve (if equipped)	<b>x</b>		<b>x</b>
Inspect for unusual noise or vibration	<b>x</b>		<b>x</b>
<b>Inspect and Clean:</b>			
Air inlet	<b>x</b>		<b>x</b>
PVC drift eliminators	<b>x</b>		<b>x</b>
Distribution basin, nozzles and collection basin	<b>x</b>		<b>x</b>
Fan motor exterior	<b>x</b>		<b>x</b>
<b>Check:</b>			
Collection water basin level	<b>x</b>		<b>x</b>
Blowdown—adjust as required	<b>x</b>		<b>x</b>
<b>Geareducer Drive</b>			
Check for loose fasteners including oil drain plug			<b>x</b>
Check for / repair oil leaks	<b>x</b>		<b>x</b>
Check oil level	<b>x</b>		<b>x</b>
Change oil		<b>R</b>	
Make sure vent is open			<b>x</b>
Check driveshaft alignment			<b>x</b>
Check for loose driveshaft or coupling fasteners			<b>x</b>
Check driveshaft flex element for unusual wear		<b>x</b>	<b>x</b>
<b>Lube lines:</b>			
Check for oil leaks in hoses or fittings	<b>x</b>		<b>x</b>
<b>Fan:</b>			
Check and tighten blade and hub fasteners			<b>x</b>
Check fan blade pitch and tip clearance			<b>x</b>
Check fan cylinder for loose fasteners			<b>x</b>
<b>Motor:</b>			
Lubricate (as required)			<b>R</b>
Check mounting bolts for tightness			<b>x</b>
Operate at least	3 hours a month	3 hours a month	3 hours a month
<b>Basin Heater (if equipped):</b>			
Check for proper operation of temp/low water level sensor			<b>x</b>
Inspect/clean buildup of contaminant from sensor		<b>x</b>	<b>x</b>
<b>Structure:</b>			
Inspect/tighten all fasteners		<b>x</b>	<b>x</b>
Inspect and touch up all metal surfaces			<b>x</b>

**R** – Refer to Component User Manual

**Note:** It is recommended at least weekly, that the general operation and condition be observed. Pay attention to any changes in sound or vibration that may signify a need for closer inspection.

---

## maintenance

---

### **Seasonal Shutdown Instructions**

When the system is to be shut down for an extended period of time, it is recommended that the entire system—cooling tower, system piping, heat exchangers, etc.—be drained. Leave the basin drain open.

During shutdown, follow recommendations in the **Cooling Tower Inspection and Maintenance** section of this manual before attempting repairs. Pay particular attention to mechanical equipment supports and driveshafts.

**Tower Framework** Check structural bolted connections and tighten as required.

**Driveshaft** Check driveshaft alignment, tightness of cap screws and set screws, and condition of all components. Refer to driveshaft service manual.

**Fan:** Check fan assembly bolting and tighten as required. Use torque settings prescribed on the fan nameplate. Refer to fan service manual.

**Fan Motor** Clean and lubricate motor (if required) at close of each operating season (refer to motor manufacturer's recommendations.) Does not apply to motors with sealed bearings. Check motor anchor bolts and tighten as required.

---

### **⚠ Warning**

***Do not start motor before determining that there will be no interference with free rotation of the fan drive.***

The motor should be operated for three hours at least once a month. This serves to dry out windings and lubricate bearing surfaces. Refer to Marley **"Fan Motor"** User Manual Z0239042 for additional information.

At start of new operating season, make sure bearings are adequately lubricated before returning motor to service. Does not apply to motors with sealed bearings.

---

## maintenance

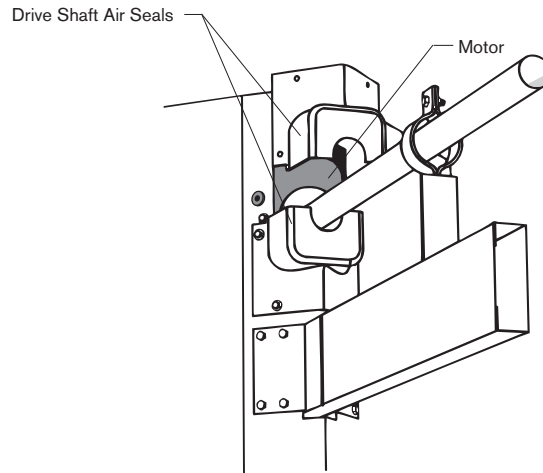

### Motor Lubrication Instructions:

---

#### **⚠ Warning**

***Open and lock out disconnect switch to make certain motor cannot be started.***

1. Remove interior driveshaft air seals as shown above. Opposite end motor bearing is accessible by removing motor cover (24000 models do not have a motor cover) on the exterior of the tower.
2. Lubricate motor according to the manufacturer's instructions. Does not apply to motors with sealed bearings.

**Fiberglass Components** Check all fiberglass parts for exposed glass fibers. If found, the affected surfaces should be roughened up and solvent wiped. Surfaces must be clean and dry and free of oil, grease or other contaminants before applying new coating. The best coating system requires using a two-part polyamide epoxy primer to promote adhesion and a two-part acrylic polyurethane enamel for the topcoat. Contact your Marley sales representative if additional information is required.

### **Prolonged Shutdown:**

If shutdown period is longer than seasonal, contact your Marley sales engineer for additional information.

---

## maintenance

---

### **Additional Services**

SPX's interest in your Marley QuadraFlow cooling tower does not end with the sale. Having conceived, designed, and manufactured the most reliable and longest lasting cooling tower of its class, we want to make sure that you gain the maximum possible benefit from its purchase.

Therefore, the following services are available which are intended to assure the maximum possible service life under your operating conditions, tailor the operating characteristics to your specific needs, and maintain consistent optimum thermal performance capability. They are available by contacting your Marley sales representative.

### **Replacement Parts:**

With the exception of the motor, every component of your tower is designed and manufactured by SPX Cooling Technologies. We do this because commercially available components have not proved capable of withstanding the harsh environment of a cooling tower—nor do they contribute their share to the thermal capability and operating characteristics intended.

A complete stock of all parts and components is maintained at one or more of the various Marley plants. In cases of emergency, they can normally be shipped within 24 hours—by air freight, if necessary. However, you would obviously benefit from anticipating your need in advance, thus avoiding the cost of special handling.

Be sure to mention your tower serial number (from the tower nameplate) when ordering parts. Refer to assembly manual for part identification.

### **Periodic Maintenance:**

You may wish to contract with Marley for regularly scheduled visits—for the purpose of inspecting and reporting your tower's condition—to make recommendations intended to prevent emergencies—and to perform maintenance considered outside the norm.

This service is not intended to replace the important function performed by your maintenance staff. Their attention assures the tower's routine operating performance, and is invaluable. However, Marley recognizes that the unusual manner in which a cooling tower performs its function—as well as the unique forces which act upon it—may be considerations which occasionally require the services of an expert technician.

---

## additional information

**Increased Load Requirements** QuadraFlow towers are designed such that cells of either equal or unequal capacity can be added in the future. This allows you to compensate for the load increases that normally occur with the replacement or addition of production equipment—and still retain continuity with respect to your cooling tower system.

**Tower Renewal** Marley routinely rebuilds and upgrades cooling towers of all materials and manufacture. If your tower ever reaches the limit of its service life, we recommend that you investigate the cost of rebuilding before you routinely order a new replacement tower.

Each QuadraFlow tower includes a document package containing general orientation drawings and manuals to accomplish field assembly and installation. ***These drawings and manuals contain important information relating to safe installation and operation of the cooling tower.*** A separate installation drawing for each purchased option is included in the document package. If you have purchased an option and can't find the appropriate installation drawing, contact your local Marley sales representative before proceeding.

SPX also provides several sets of a separate packet of pertinent operating and maintenance manuals. The manuals vary somewhat depending on the tower model purchased.

In addition, SPX publishes numerous technical reports including more detailed information on a variety of cooling tower operation and service topics available to download at [spxcooling.com](http://spxcooling.com). For complete parts and service assistance, contact the Marley sales or representative office in your area. If you need help locating the office nearest you, please phone 603 7947 7800 or check the web at [spxcooling.com](http://spxcooling.com).

## troubleshooting

Trouble	Cause	Remedy
Motor will not start		Check power at starter. Correct any bad connections between the control apparatus and the motor.
	Power not available at motor terminals	Check starter contacts and control circuit. Reset overloads, close contacts, reset tripped switches or replace failed control switches.
		If power is not on all leads at starter, make sure overload and short circuit devices are in proper condition.
	Wrong connections	Check motor and control connections against wiring diagrams.
	Low voltage	Check nameplate voltage against power supply. Check voltage at motor terminals.
	Open circuit in motor winding	Check stator windings for open circuits.
Unusual motor noise	Fan drive stuck	Disconnect motor from load and check motor and Geareducer for cause of problem.
	Rotor defective	Look for broken bars or rings.
	Motor running single-phase	Stop motor and attempt to start it. Motor will not start if single phased. Check wiring, controls and motor.
	Motor leads connected incorrectly	Check motor connections against wiring diagram on motor.
	Bad bearings	Check lubrication. Replace bad bearings.
	Electrical unbalance	Check voltages and currents of all three lines. Correct if required.
Motor runs hot	Air gap not uniform	Check and correct bracket fits or bearing.
	Rotor unbalance	Rebalance.
	Cooling fan hitting end bell-guard	Reinstall or replace fan
	Wrong voltage or unbalanced voltage	Check voltage and current of all three lines against nameplate values.
	Overload	Check fan blade pitch. See Fan User Manual. Check for drag in fan drivetrain as from damaged bearings.
	Wrong motor RPM	Check nameplate against power supply. Check RPM of motor and gear ratio.
	Bearings over greased	Remove grease reliefs. Run motor up to speed to purge excessive grease. Does not apply to motors with sealed bearings.
	Wrong lubrication in bearings	Change to proper lubricant. See motor manufacturer's instructions.
	One phase open	Stop motor and attempt to start it. Motor will not start if single phased. Check wiring controls and motor
	Poor ventilation	Clean motor and check ventilation openings. Allow ample ventilation around motor.
	Winding fault	Check with Ohmmeter.
	Bent motor shaft	Straighten or replace shaft.
	Insufficient grease	Remove plugs and regrease bearings. Does not apply to motors with sealed bearings.
	Too frequent starting or speed changes	Limit cumulative acceleration time to a total of 30 seconds per hour. Set on/off or speed change set-points farther apart. Consider installing a Marley VFD for fine temperature control.
Deterioration of grease or foreign material in grease	Flush bearings and relubricate. Does not apply to motors with sealed bearings.	
Bearings damaged	Replace bearings.	

# troubleshooting

<b>Trouble</b>	<b>Cause</b>	<b>Remedy</b>
Motor does not come up to speed	Voltage too low at motor terminals because of line drop	Check transformer and setting of taps. Use higher voltage on transformer terminals or reduce loads. Increase wire size or reduce inertia.
	Broken rotor bars	Look for cracks near the rings. A new rotor may be required. Have motor service person check motor.
Wrong motor rotation	Wrong sequence of phases	Switch any two of the three motor leads.
Geareducer noise	Geareducer bearings	If new, see if noise disappears after one week of operation. Drain, flush and refill Geareducer oil. See Geareducer User Manual. If still noisy, replace.
	Gears	Correct tooth engagement. Replace badly worn gears. Replace gears with broken or damaged teeth
Unusual fan drive vibration	Loose bolts and cap screws	Tighten all bolts and cap screws on all mechanical equipment and supports.
	Unbalanced driveshaft or worn couplings	Make sure motor and Geareducer shafts are in proper alignment and "match marks" properly matched. Repair or replace worn couplings. Rebalance driveshaft by adding or removing weights from balancing cap screws. See Driveshaft User Manual.
	Fan	Make certain all blades are as far from center of fan as safety devices permit. All blades must be pitched the same. See Fan User Manual. Clean off deposit build-up on blades
	Worn Geareducer bearings	Check fan and pinion shaft endplay. Replace bearings as necessary.
	Unbalanced motor	Disconnect load and operate motor. If motor still vibrates, rebalance motor.
	Bent Geareducer shaft	Check fan and pinion shaft with dial indicator. Replace if necessary.
Fan noise	Blade rubbing inside of fan cylinder	Adjust cylinder to provide blade tip clearance.
	Loose bolts in blade clamps	Check and tighten if necessary
Scale or foreign substance in circulating water system	Insufficient blowdown	See "Water Treatment" section of this manual.
	Water treatment deficiency	Consult competent water treating specialist. See "Water Treatment" section of this manual.
Cold-water temperature too warm (see "Tower Operation")	Entering wet-bulb temperature is above design	Check to see if local heat sources are affecting tower. See if surrounding structures are causing recirculation of tower discharge air. Discuss remedy with Marley representative.
	Design wet-bulb temperature was too low	May have to increase tower size. Discuss remedy with Marley representative.
	Actual process load greater than design	May have to increase tower size. Discuss remedy with Marley representative.
	Overpumping	Reduce water flow over tower to design conditions.
Excessive drift exiting tower	Tower starved for air	Check motor current and voltage to be sure of correct contract power. Repitch fan blades if necessary. Clean louvers, fill and eliminators. Check to see if nearby structure or enclosing walls are obstructing normal airflow to tower. Discuss remedy with Marley representative.
	Distribution basins overflowing	Reduce water flow rate over tower to design conditions. Be sure hot water basin nozzles are in place and not plugged.
	Faulty drift elimination	Check to see that integral fill, louvers and eliminators are clean, free of debris and installed correctly. If drift eliminators are separate from fill, make sure they are correctly installed in place. Clear if necessary. Replace damaged or worn out components.

---

**SPX COOLING TECHNOLOGIES MALAYSIA Sdn Bhd**

UNIT 505, BLOCK B, PHILEO DAMANSARA 2

NO. 15 JALAN 16/11, OFF JALAN DAMANSARA

46350 PETALING JAYA, MALAYSIA

60 3 7947 7800 | [th.my.enquiry@spx.com](mailto:th.my.enquiry@spx.com)

[spxcooling.com](http://spxcooling.com)

sea\_Z0238885\_D | ISSUED 8/2018

© 2010-2017 SPX COOLING TECHNOLOGIES, INC. | ALL RIGHTS RESERVED

In the interest of technological progress, all products are subject to design and/or material change without notice.

