

# AV6800

STEEL COOLING TOWER

engineering data  
and specifications



Engineering Data	
<hr/>	
Schematic	4
Outlet Piping	14
Support	16
Freeze Prevention	18
Environmental	19
Application	20
Specifications / Base	
<hr/>	
Base	21
Thermal Performance	22
Performance Warranty	22
Design Loading	22
Construction	23
Mechanical Equipment	24
Fill, Louvers, and Drift Eliminators	25
Hot Water Distribution System	26
Casing, Fan Deck and Fan Guard	26
Access	26
Cold Water Collection Basin	27
Specifications / Options	
<hr/>	
<b>Stainless Steel Options</b>	
All Stainless Steel Cooling Tower	28
Stainless Steel Collection Basin	28
Stainless Steel Distribution System	29
<b>Control Options</b>	
Fan Motor Starter Control Panel	29
Terminal Box	30
Vibration Limit Switch	30
Basin Heater	31
Fan Motor Variable Speed Drive	31
Single-Point Power Connection	32
Motor Sequencer with RTD	33
Water Level Control System	33
<b>Convenience and Safety Options</b>	
Hot Water Basin Access Platform	34
Hot Water Basin Guardrail System	34
Ladder Extension	34
Ladder Safety Cage	35
Mechanical Equipment Access Platform	35
Access Door Platform	35
<b>Miscellaneous Options</b>	
Fan Cylinder Extensions	36
Equalizer Flume Weir Gates	36
Inlet Flow Control Valve	36
Variable Water Flow Distribution	36
FM Approval	37
Air Inlet Screens	37
Basin Sweeper Piping	37
High Wind Load/Seismic Design	37
Quiet Fan	38
Ultra Quiet Fan	38



**AV** towers are galvanized steel, factory-assembled, general purpose crossflow cooling towers, designed to serve normal air conditioning and refrigeration systems as well as light industrial loads. They evolve from a singleflow concept of towers pioneered by Marley in the 1950s, and incorporate all of the design advancements that our customers have found valuable. They represent the current state of the art in this cooling tower category.

This booklet not only relates the language to use in describing an appropriate AV cooling tower—but also defines why certain items and features are important enough to specify with the intention of insisting upon compliance by all bidders. The left hand column of pages 21 thru 38 provides appropriate text for the various specification paragraphs, whereas the right hand column comments on the meaning of the subject matter and explains its value.

Pages 21 thru 27 indicate those paragraphs which will result in the purchase of a basic cooling tower—one that accomplishes the specified thermal performance, but which will lack many operation—and maintenance-enhancing accessories and features that are usually desired by those people who are responsible for the continued and continuing operation of the system of which the tower is part. It will also incorporate those standard materials which testing and experience has proven to provide acceptable longevity in normal operating conditions.

Pages 28 thru 38 provide paragraphs intended to add those features, components, and materials that will customize the tower to meet the user's requirements.

AV6805

Use this data for preliminary layouts only. Obtain current drawing from your Marley sales representative.

**UPDATE™** web-based selection software, available at [spxcooling.com/update](http://spxcooling.com/update) provides AV cooling tower model recommendations based on customer's specific design requirements.

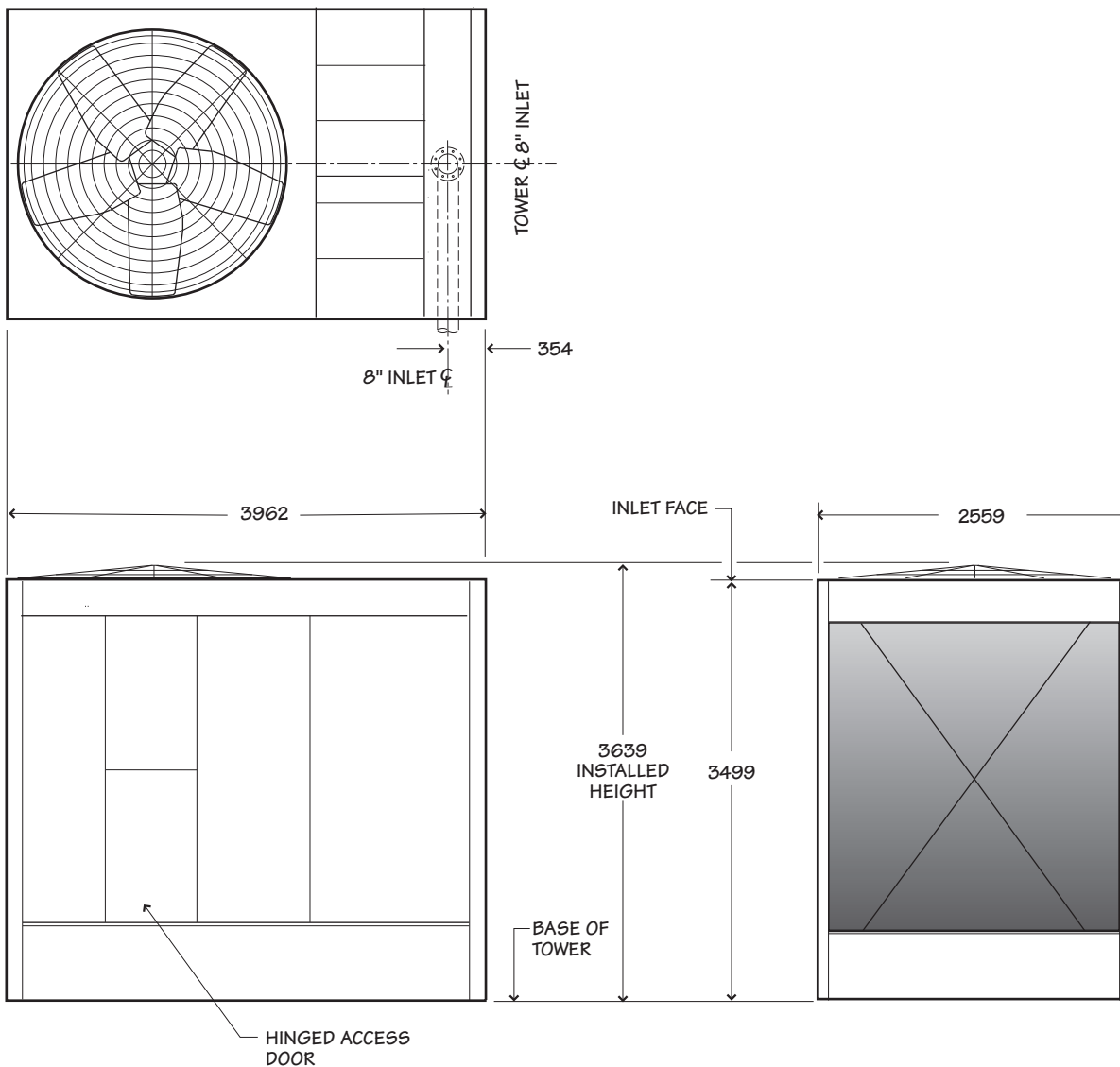

AV6805

Tower Model	Nominal Capacity kW note 2	Motor kW	Design Operating Wt/Cell kg	Shipping Wt/Cell kg
AV6805HAN	550	2.2	4585	2488
AV6805KAN	633	4		
AV6805MAN	721	5.5		
AV6805NAN	783	7.5		
AV6805PAN	897	11		
AV6805QAN	989	15		

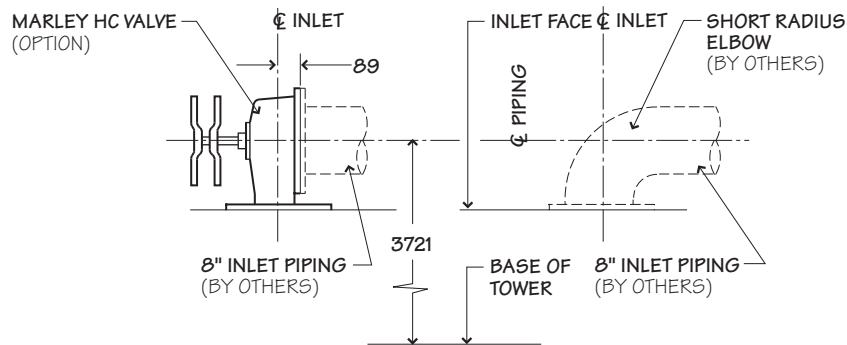

INLET PIPING DETAILS

NOTE

- 1 **Use this bulletin for preliminary layouts only.** Obtain current drawings from your Marley sales representative. All table data is per cell.
- 2 Nominal cooling capacity based upon 35°C HW, 29.5°C CW, 25.5°C WB and 0.155 m<sup>3</sup>/hr per kW.
- 3 Standard overflow is a 4" dia. in the collection basin floor.
- 4 Outlet sizes vary according to gpm and arrangement. See pages 14 and 15 for outlet sizes and details.
- 5 Makeup water connection may be 1" or 2" dia., depending upon tower heat load, water pressure, and desired connections. See page 14 for additional information.

AV6807

Use this data for preliminary layouts only. Obtain current drawing from your Marley sales representative.

**UPDATE™** web-based selection software, available at [spxcooling.com/update](http://spxcooling.com/update) provides AV cooling tower model recommendations based on customer's specific design requirements.

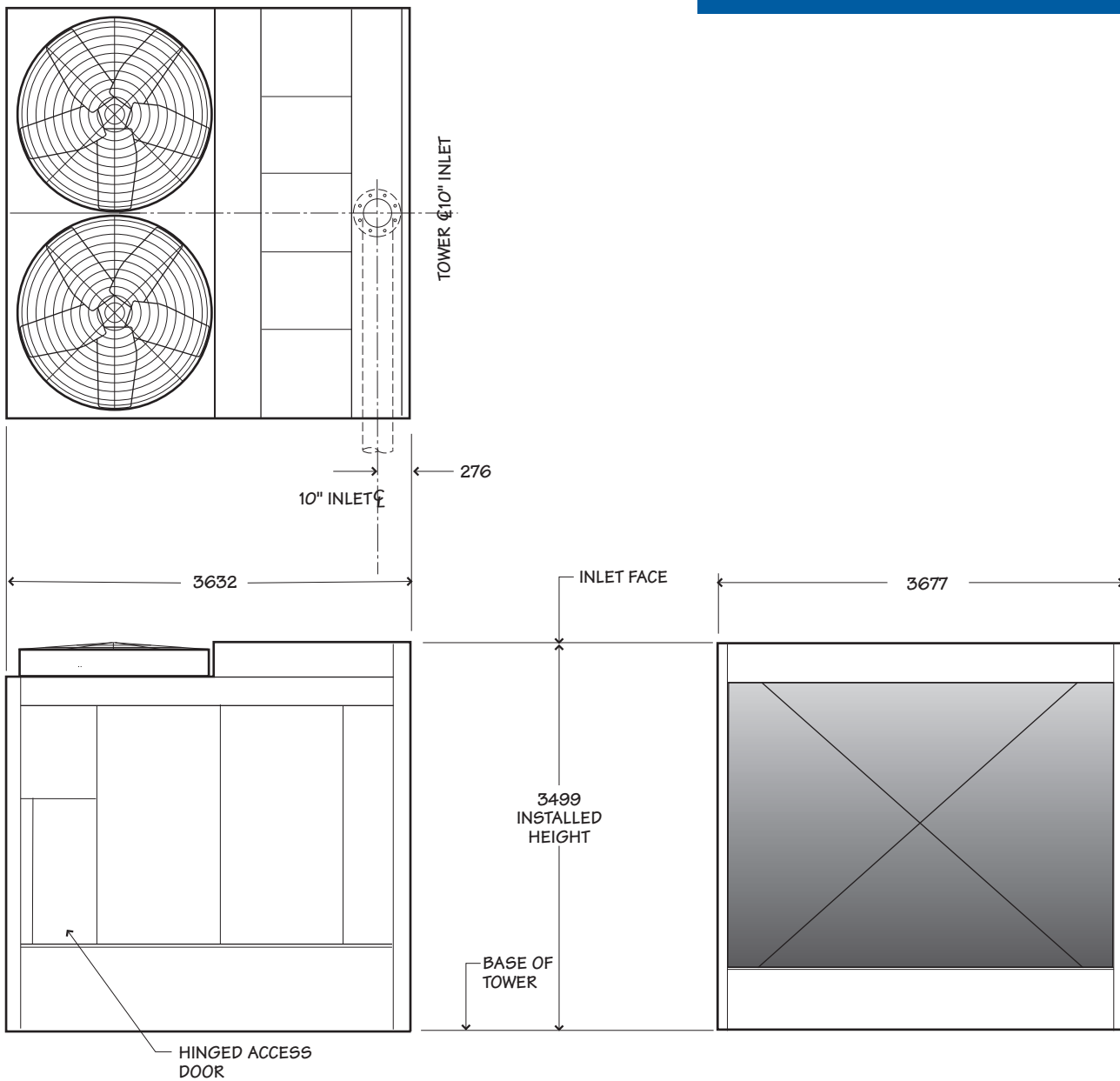

Tower Model	Nominal Capacity kW note 2	Motor kW	Design Operating Wt/Cell kg	Shipping Wt/Cell kg
AV6807HAN	721	2.2	6127	3129
AV6807JAN	778	3		
AV6807KAN	831	4		
AV6807LAN	884	4.5		
AV6807MAN	945	5.5		
AV6807NAN	1011	7.5		
AV6807PAN	1156	11		
AV6807QAN	1288	15		
AV6807RAN	1398	25		
AV6807SAN	1481	18.5		
AV6807TAN	1635	30		

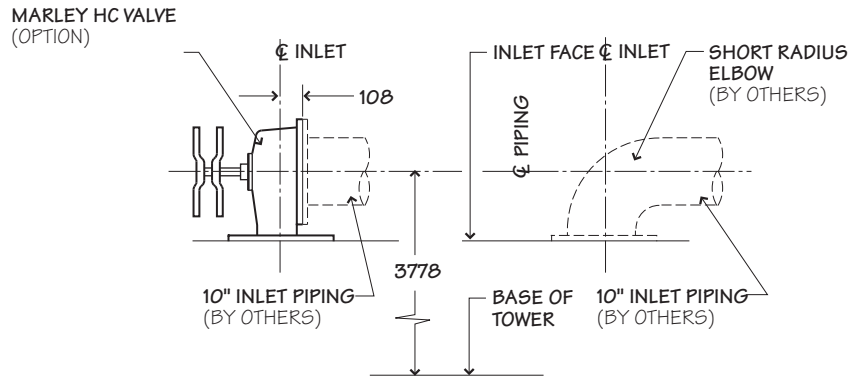

INLET PIPING DETAILS

NOTE

- 1 **Use this bulletin for preliminary layouts only.** Obtain current drawings from your Marley sales representative. All table data is per cell.
- 2 Nominal cooling capacity based upon 35°C HW, 29.5°C CW, 25.5°C WB and 0.155 m<sup>3</sup>/hr per kW.
- 3 Standard overflow is a 4" dia. in the collection basin floor.
- 4 Outlet sizes vary according to gpm and arrangement. See pages 14 and 15 for outlet sizes and details.
- 5 Makeup water connection may be 1" or 2" dia., depending upon tower heat load, water pressure, and desired connections. See page 14 for additional information.

AV6809

Use this data for preliminary layouts only. Obtain current drawing from your Marley sales representative.

**UPDATE™** web-based selection software, available at [spxcooling.com/update](http://spxcooling.com/update) provides AV cooling tower model recommendations based on customer's specific design requirements.

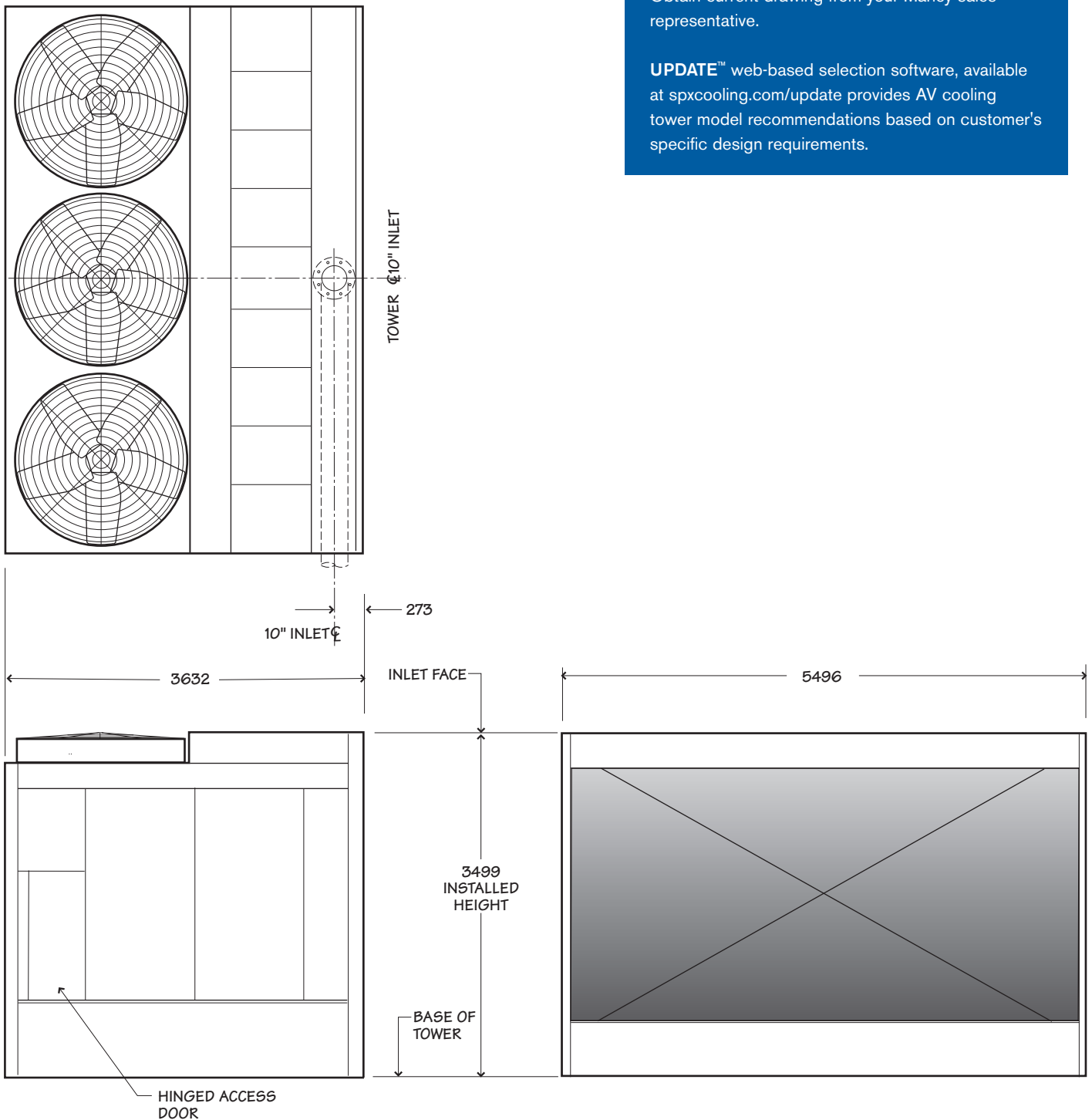



Tower Model	Nominal Capacity kW note 2	Motor kW	Design Operating Wt./Cell kg	Shipping Wt./Cell kg
AV6809KAN	1055	4	8663	4383
AV6809LAN	1152	4.5		
AV6809AAN	1301	6.7		
AV6809PAN	14909	11		
AV6809BAN	1710	16.5		
AV6809SAN	1899	22		
AV6809CAN	2035	28		
AV6809EAN	2185	33		

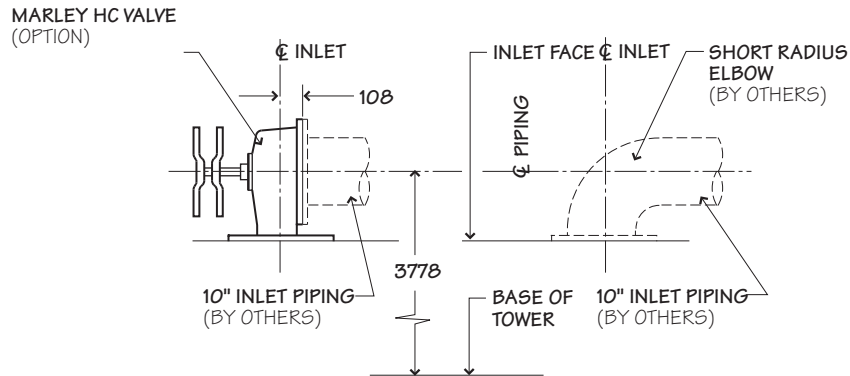

INLET PIPING DETAILS

NOTE

- 1 **Use this bulletin for preliminary layouts only.** Obtain current drawings from your Marley sales representative. All table data is per cell.
- 2 Nominal cooling capacity based upon 35°C HW, 29.5°C CW, 25.5°C WB and 0.155 m<sup>3</sup>/hr per kW.
- 3 Standard overflow is a 4" dia. in the collection basin floor.
- 4 Outlet sizes vary according to gpm and arrangement. See pages 14 and 15 for outlet sizes and details.
- 5 Makeup water connection may be 1" or 2" dia., depending upon tower heat load, water pressure, and desired connections. See page 14 for additional information.

AV6817

Use this data for preliminary layouts only. Obtain current drawing from your Marley sales representative.

**UPDATE™** web-based selection software, available at [spxcooling.com/update](http://spxcooling.com/update) provides AV cooling tower model recommendations based on customer's specific design requirements.

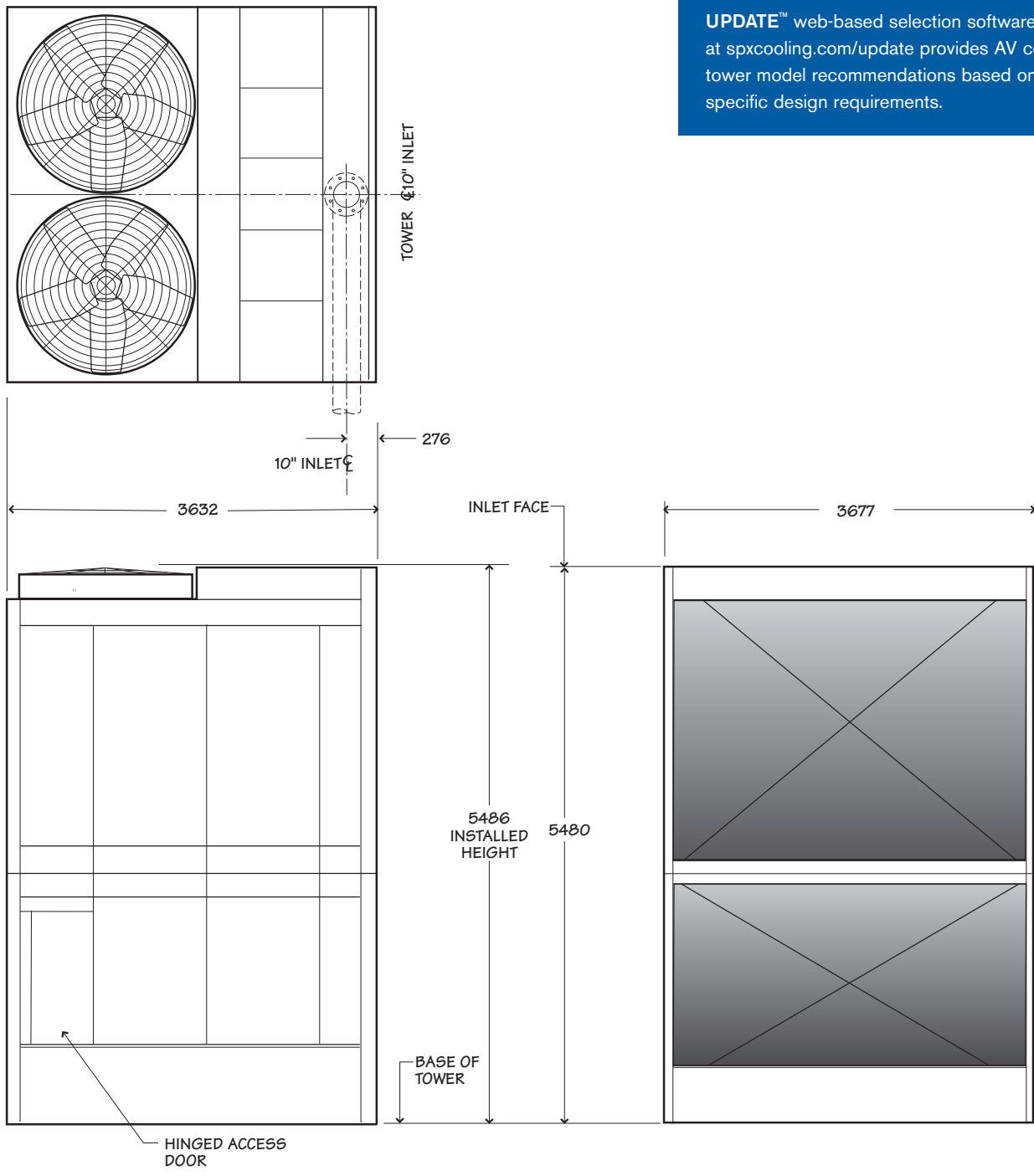

AV6817

Tower Model	Nominal Capacity kW note 2	Motor kW	Design Operating Wt./Cell kg	Shipping Wt./Cell kg
AV6817HAN	950	2.2	8528	4202
AV6817JAN	1037	3		
AV6817KAN	1112	4		
AV6817LAN	1174	4.5		
AV6817MAN	1257	5.5		
AV6817NAN	1372	7.5		
AV6817PAN	1563	11		
AV6817QAN	1736	15		
AV6817RAN	1886	18.5		
AV6817SAN	2013	22		
AV6817TAN	2207	30		

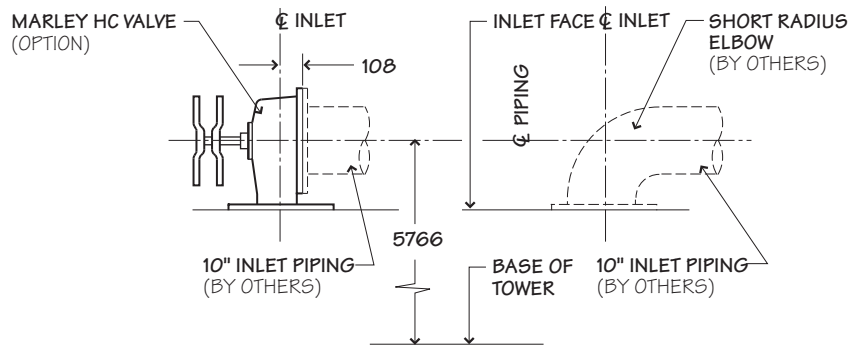

INLET PIPING DETAILS

NOTE

- Use this bulletin for preliminary layouts only.** Obtain current drawings from your Marley sales representative. All table data is per cell.
- Nominal cooling capacity based upon 35°C HW, 29.5°C CW, 25.5°C WB and 0.155 m<sup>3</sup>/hr per kW.
- Standard overflow is a 4" dia. in the collection basin floor.
- Outlet sizes vary according to gpm and arrangement. See pages 14 and 15 for outlet sizes and details.
- Makeup water connection may be 1" or 2" dia., depending upon tower heat load, water pressure, and desired connections. See page 14 for additional information.

AV6819

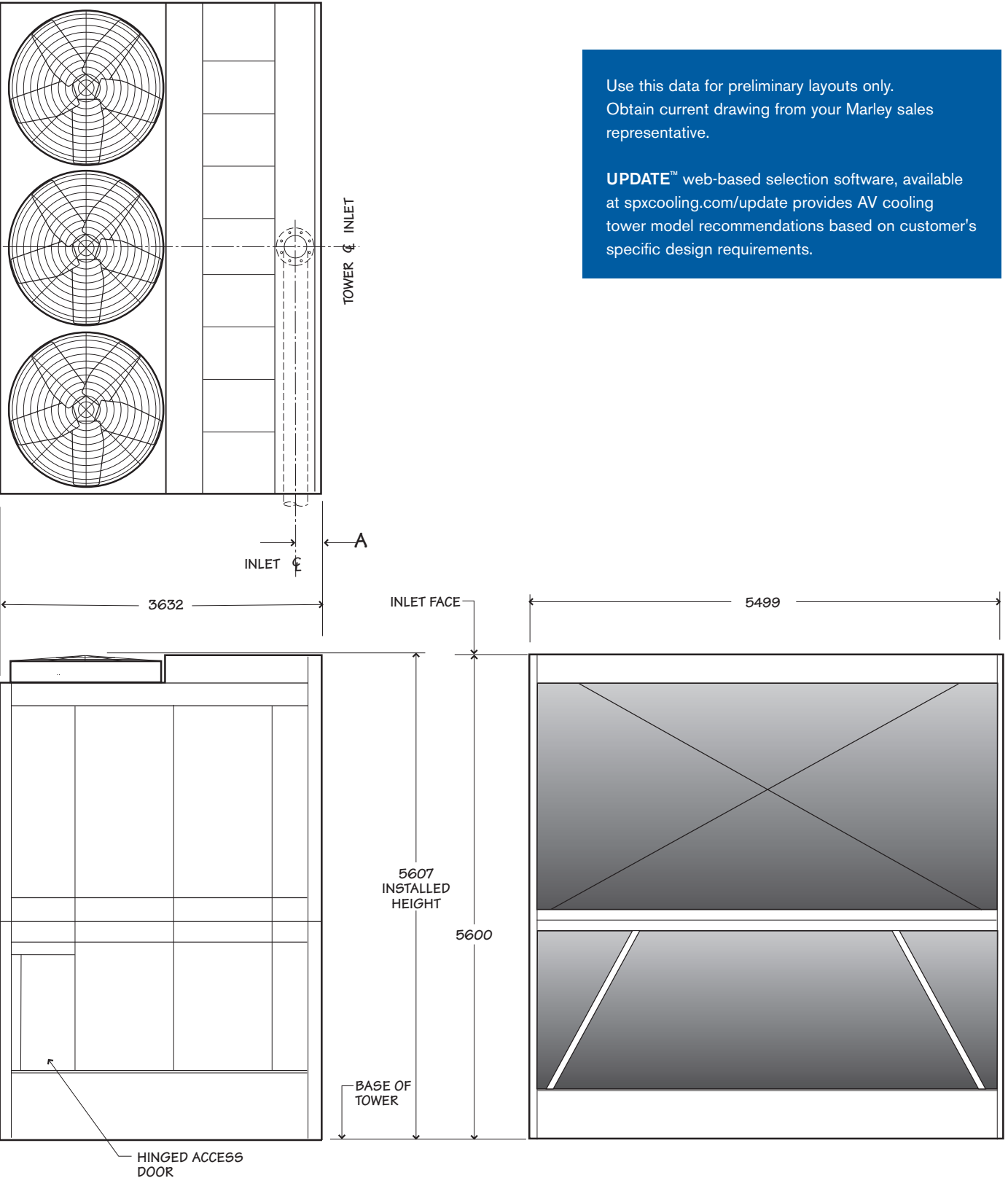

Use this data for preliminary layouts only. Obtain current drawing from your Marley sales representative.

**UPDATE™** web-based selection software, available at [spxcooling.com/update](http://spxcooling.com/update) provides AV cooling tower model recommendations based on customer's specific design requirements.

AV6819

Tower Model	Nominal Capacity kW note 2	Motor kW	10" Inlet			12" Inlet			Design Operating Wt/Cell kg	Shipping Wt/Cell kg
			A	C	P	A	C	P		
AV6819KAN	1429	4	273	108	5867	311	124	5867	12299	6142
AV6819LAN	1561	4.5								
AV6819AAN	1763	6.7								
AV6819PAN	2062	11								
AV6819BAN	2361	16.5								
AV6819SAN	2616	22								
AV6819CAN	2831	28								
AV6819EAN	3033	33								
AV6819VAN	3394	45								

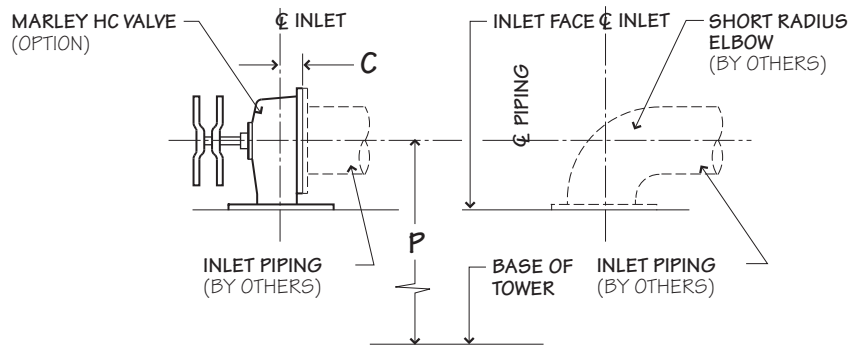

INLET PIPING DETAILS

NOTE

- 1 **Use this bulletin for preliminary layouts only.** Obtain current drawings from your Marley sales representative. All table data is per cell.
- 2 Nominal cooling capacity based upon 35°C HW, 29.5°C CW, 25.5°C WB and 0.155 m<sup>3</sup>/hr per kW.
- 3 Standard overflow is a 4" dia. in the collection basin floor.
- 4 Outlet sizes vary according to gpm and arrangement. See pages 14 and 15 for outlet sizes and details.
- 5 Makeup water connection may be 1" or 2" dia., depending upon tower heat load, water pressure, and desired connections. See page 14 for additional information.

**OUTLET AND MAKEUP PIPING DETAILS**

Unless otherwise specified, single-cell towers normally have a side-outlet suction appropriate for the design water flow rate—see page 15. This usually assures the lowest possible installed tower elevation. Side-suction connection pipes extend roughly 3" outside the basin, and are beveled for weld connection and also grooved for a mechanical coupling.

Outlet piping can be kept below the cold water basin level by choosing a bottom outlet connection in lieu of the side suction. Bottom outlet design conform to standard class 125/150 ANSI pipe flange specifications. All outlet arrangements include easily removable debris screens.

Multicell towers, intended to operate together as a common unit, are joined by steel flumes between the collection basins. These flumes equalize the operating water level between basins and also provide a flow passage from cells not equipped with outlets or makeup valves, often eliminating the need to specify an outlet and makeup valve for each cell on a multicell installation. Refer to sales drawings to obtain flow values of suctions and bottom outlets for multicell installations.

The best choice for a tower used with a remote or indoor storage tank—see page 18—on a concrete cold water basin is usually a bottom outlet, with or without screen.

**MAKEUP**

The amount of water constantly evaporated from a cooling tower varies directly with the heat load applied. In addition to evaporation, water is normally lost to the blowdown (bleed-off) necessary to maintain dissolved solids concentration at an acceptable level in the circulating water system.

The AV tower is equipped with a float-operated, mechanical makeup valves to automatically replenish this lost water. The following tables, calculated for a concentration of 3 times normal, indicate the rate of water loss, and the size of valve(s) required. If your installation's cold water basin will drain by gravity to a remote storage tank, or if you plan a separate means of controlling makeup water, we offer a price reduction for deleting the makeup valve.

Tower m <sup>3</sup> /hr	Makeup Water Flow Required – m <sup>3</sup> /hr to Maintain Three (3) Concentrations					
	Cooling "Range" (hot water minus cold water)					
	3°C	6°C	8°C	12°C	17°C	24°C
45	.5	.7	.9	1	2	2
91	.7	1	2	2	3	5
136	.9	2	3	3	5	7
182	1	2	3	5	7	9
227	2	3	4	6	9	11
341	2	4	7	9	13	17
454	3	6	9	11	17	23
681	4	9	13	17	26	34
908	6	11	17	23	34	45
1135	7	14	21	28	43	57
1362	9	17	26	34	51	68
1816	11	23	34	45	68	91

**NOTE**

- If circulating water is to be maintained at 2 concentrations instead of 3, multiply table m<sup>3</sup>/hr values by 1.36 before sizing makeup valve.

Makeup Valve Flow Capacities – m <sup>3</sup> /hr		
Pressure at Valve Inlet while flowing–kPa	1" Diameter Valve	2" Diameter Valve
69	13	20
138	18	27
207	21	33
276	24	36
345	27	38

**NOTE**

- If makeup water pressure exceeds 345 kPa, use pressure reducer ahead of valve.
- For flow requirements exceeding the above limitations, use multiples of the same size valve.

Outlet Type	Flow Type	Model	Maximum Flow Per Outlet Diameter m <sup>3</sup> /hr									
			Outlet Diameter									
			4"	6"	8"	10"	12"	14"	16"	18"	20"	24"
Bottom	pump flow w/ anti-vortex plate or gravity flow w/ or w/o anti-vortex plate	AV6805	37	81	143	226	321	393	519	570	755	913
		AV6807 thru AV6819	38	86	153	241	343	420	555	719	870	1112
	pump flow w/o anti-vortex plate	AV6805 thru AV6819	16	37	65	103	146	179	237	306	381	553
Sump	pump flow w/ anti-vortex plate or gravity flow w/ or w/o anti-vortex plate	AV6805		204	362	571	813	995				
		AV6807 thru AV6819		204	362	571	813	995				
	pump flow w/o anti-vortex plate	AV6805 thru AV6819		143	253	400	569	696				
Cased-Face Outlet	pump flow only	AV6805		204	362							
		AV6807 thru AV6819		204	362	571	813					

**NOTE**

- 1 For gravity-flow situations (as to an indoor tank), use bottom outlet. Side outlet suction is not recommended for gravity flow.
- 2 Flow limits are based on single-cell or multicell towers with a single

outlet per cell. For multicell towers connected with collection basin flumes and less than one outlet per tower cell consult your Marley sales representative for more specific information.

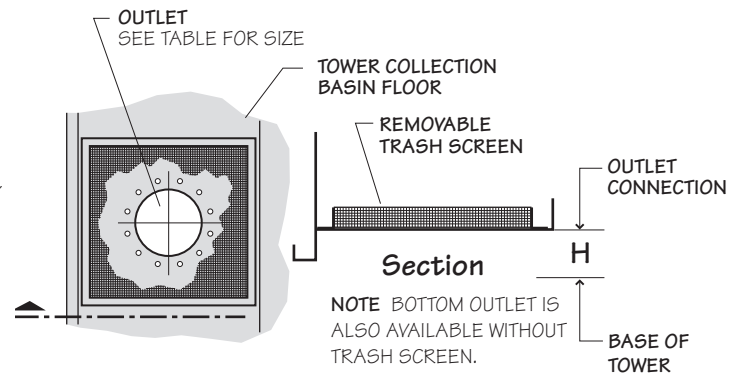
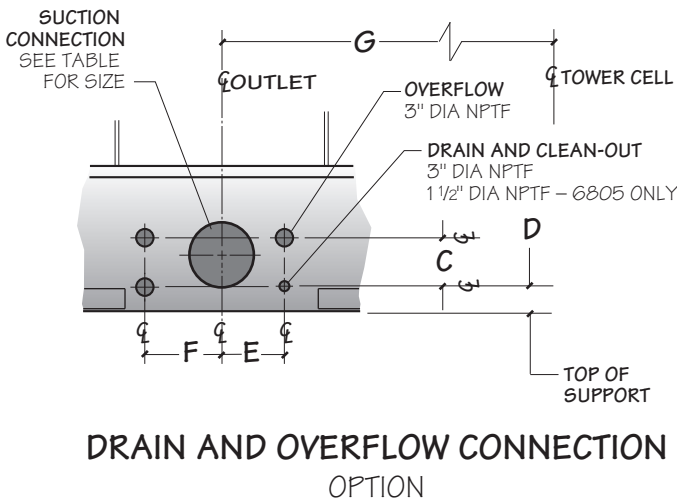
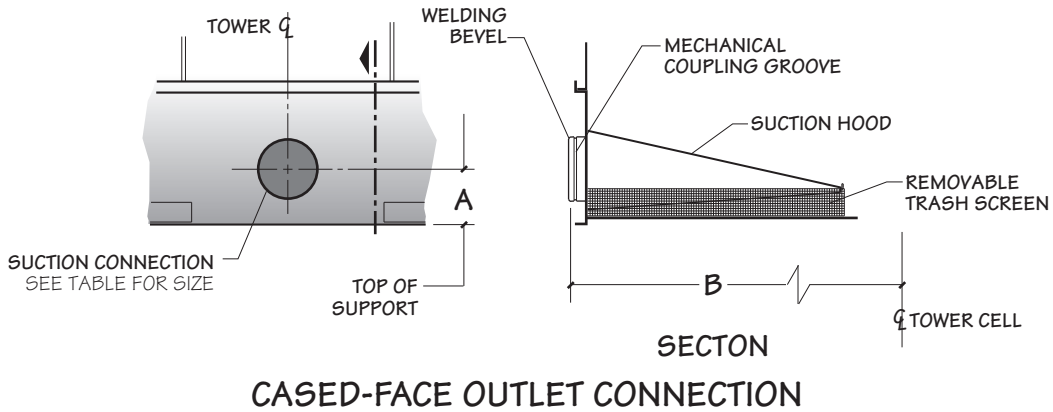

**NOTE**

- Standard overflow is a 4" dia. standpipe in the collection basin floor. The standpipe removes for flush-out and draining.

Tower Model	Dimensions								
	A		B	C	D	E	F	G	H
	10"	12"							
AV6805	286		1305	121	116	327		787	38
AV6807	216	248	1857	173	76		371	1238	43
AV6809	257	283	2772	173	129		371	1238	95
AV6817	216	248	1857	173	76		371	1238	43
AV6819	257	283	2772	173	129		371	1238	95

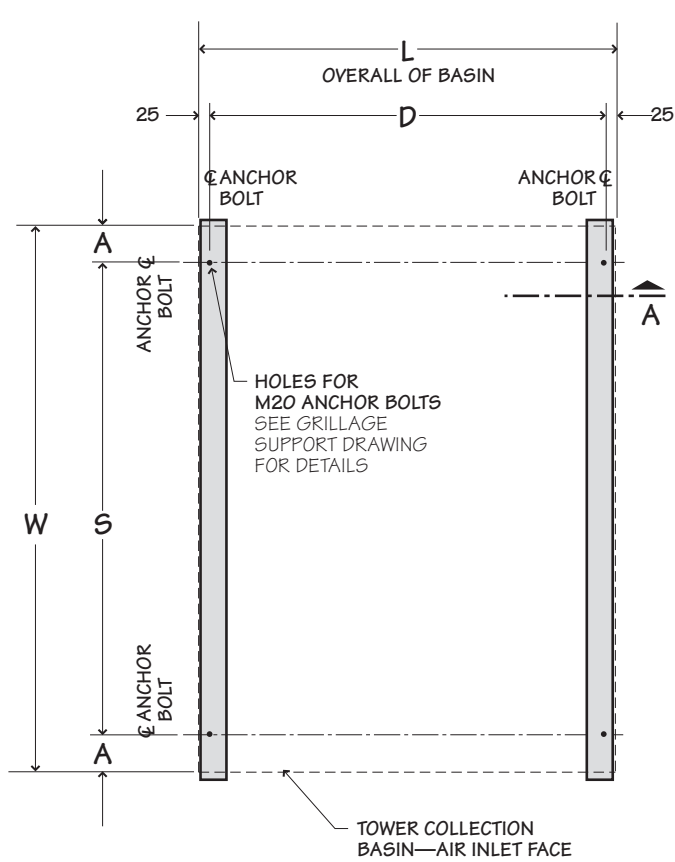

**SUPPORTING STEEL  
OPTION ONE**

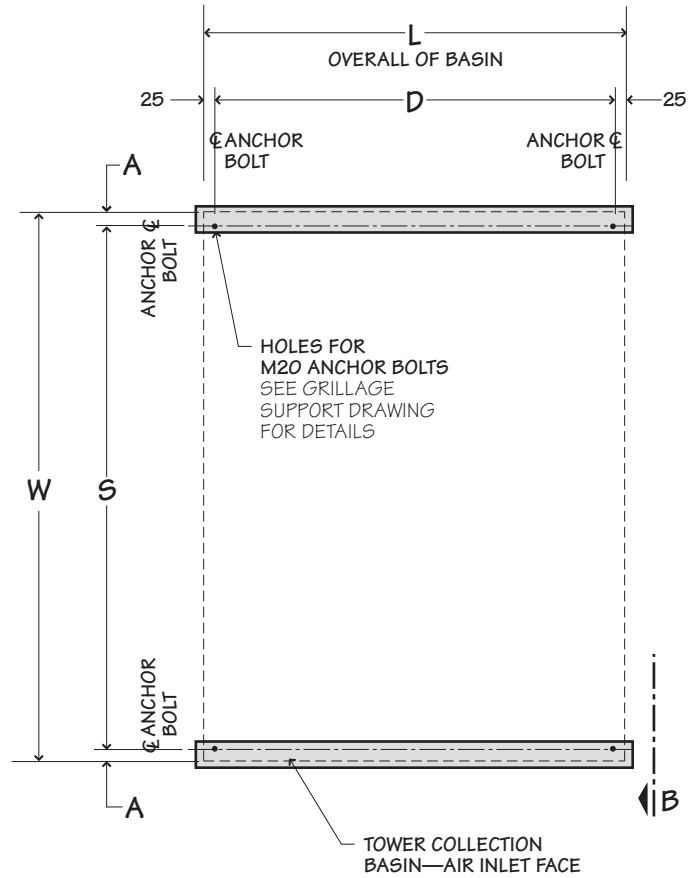

**SUPPORTING STEEL  
OPTION TWO**

Tower Model	Dimensions					Design Operating Weight/Cell kg	Design Operating Load at Anchor kg
	L	D	W	S	A		
AV6805	2540	2489	3962	800	57	4585	1216
AV6807	3677	3626	3632	3454	83	5923	1743
AV6809	5499	5448	3632	3454	73	8663	2404
AV6817	3677	3626	3632	3454	73	8518	2396
AV6819	5499	5448	3632	3454	83	12299	8117



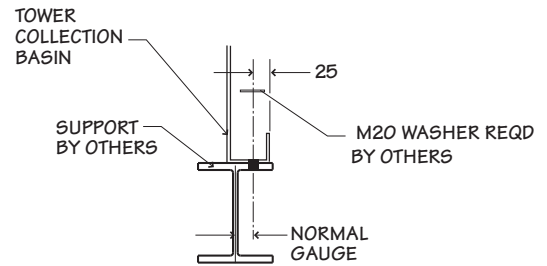
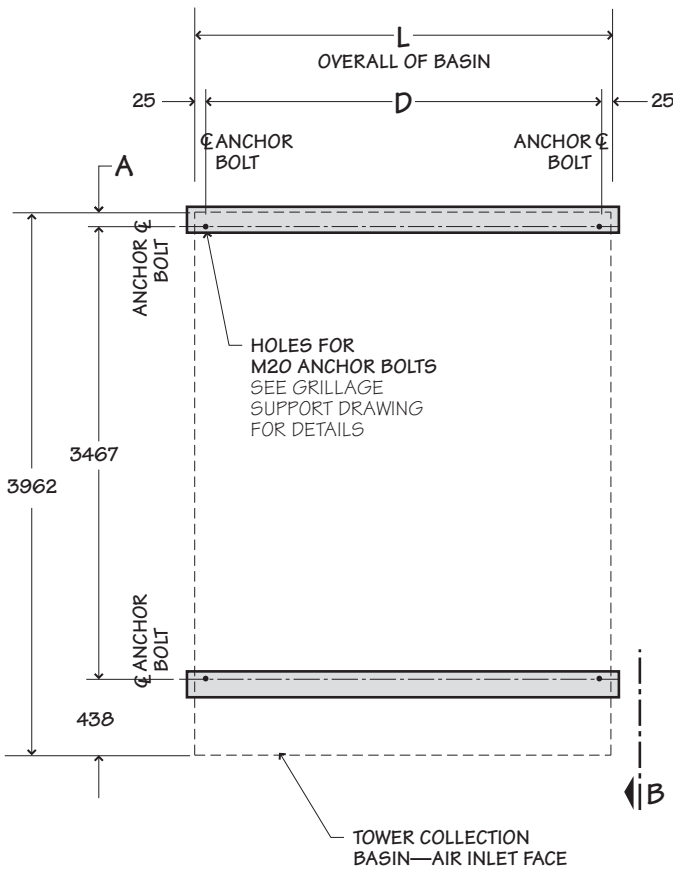

SECTION A

**SUPPORTING STEEL  
OPTION THREE – 6805 ONLY**

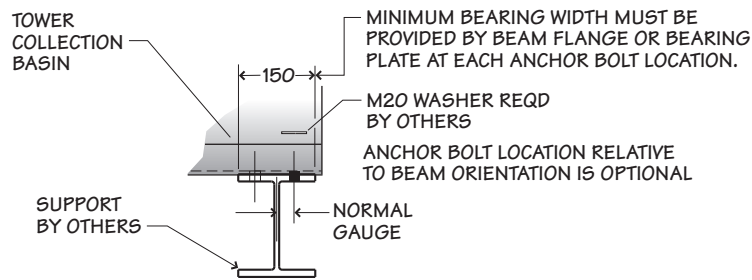

VIEW B

**NOTE**

- 1 Use this bulletin for preliminary layouts only. Obtain current drawings from your Marley sales representative for final design.
- 2 Purchaser to provide tower support complete with holes and anchor bolts. Do not use studs! Anchor points must be framed flush and level at top.
- 3 Design operating weight occurs with collection basin full to overflow level. Actual operating weight varies with flow and piping scheme.
- 4 Tower may be placed on a flat concrete slab. Side outlet must be specified. See pages 14 and 15 and consult your Marley application sales representative.
- 5 Tower may be supported from piers at each anchor bolt location, as a support alternative.

When the ambient air temperature falls below 32°F, the water in a cooling tower can freeze. *Marley Technical Report #H-003 “Cooling Towers and Freezing Weather”* describes how to prevent freezing during operation. Available at [spxcooling.com](http://spxcooling.com) or ask your Marley sales representative for a copy.

During shutdown, water collects in the cold water basin and may freeze solid. You can prevent freezing by adding heat to the water left in the tower—or, you can drain the tower and all exposed pipework at shutdown.

### ELECTRIC BASIN HEATERS

An automatic basin water heater system is available consisting of the following components:

- Stainless steel electric immersion heater(s).
  - Threaded couplings are provided in the side of the collection basin.
- IP56 enclosure containing:
  - Magnetic contactor to energize heater.
  - Transformer to convert power supply to 24 volts for control circuit.
  - Solid state circuit board for temperature and low-water cutoff.Enclosure may be mounted on the side of the tower.
- Control probe in the collection basin to monitor water temperature and level.

Heater components are normally shipped separately for installation by others.

**Note:** any exposed piping that is still filled with water at shutdown—including the makeup water line—should be electrically traced and insulated (by others).

### STEAM JET BASIN HEATER

Penberthy Houdaille bronze steam jet heaters (¼" to ¾") are available for freeze protection (installation by others). Injectors install in a coupling provided in the side of the collection basin. Live steam, as required, is injected directly into the water. Condensed steam adds water to the basin, and the excess will exit the overflow of the tower.

### INDOOR STORAGE TANK

With this type of system, water flows from an indoor tank, through the load system, and back to the tower, where it is cooled. The cooled water flows by gravity from the tower to the tank located in a heated space. At shutdown, all exposed water drains into the tank, where it is safe from freezing.

The amount of water needed to successfully operate the system depends on the tower size and GPM and on the volume of water contained in the piping system to and from the tower. You must select a tank large enough to contain those combined volumes—plus a level sufficient to maintain a flooded suction on your pump. Control makeup water according to the level where the tank stabilizes during operation.

## SOUND CONTROL

Sound produced by an AV Series tower operating in an unobstructed environment will meet all but the most restrictive noise limitations—and will react favorably to natural attenuation. Where the tower has been sized to operate within an enclosure, the enclosure itself will have a damping effect on sound. Sound also declines with distance—by about 6 dBA each time the distance doubles.

All standard AV cooling towers are equipped with low sound fans. This in combination with zero-splash crossflow film-fill results in a line of towers capable of meeting most noise limitations. Where noise at a critical point is likely to exceed an acceptable limit, several other options are available—listed below in ascending order of cost impact:

- The Marley "Quiet Package" includes the affordable Quiet Fan mechanical option, optimized to achieve the lowest possible sound levels while maintaining efficiency.
- A Marley Variable Speed Drive automatically minimizes the tower's noise level during periods of reduced load and/or reduced ambient temperature without sacrificing the system's ability to maintain a constant cold water temperature. This is a relatively inexpensive solution, and can pay for itself quickly in reduced energy costs. The natural nighttime reduction in wetbulb temperature makes this a very feasible solution in most areas of the world. It also eliminates fan cycling. In combination with a Marley Quiet Package, the Marley Variable Speed Drive is capable of meeting all but the most restrictive noise limitations.
- For more severe cases requiring the lowest possible fan sound levels the Marley "Ultra Quiet" fan option is now available on most AV models. Tower height will increase—obtain current sales drawings from your Marley sales representative for accurate dimensions.
- Extreme cases may require inlet and discharge sound attenuator sections—however, the static pressure loss imposed by attenuators may necessitate an increase in tower size. This is the least desirable approach because of the significant cost impact—and because of the obstruction to normal maintenance procedures.

Although not an industry requirement, all published sound data on Marley cooling towers are in accordance with CTI ATC128 so you can be assured of sound data accuracy.

## ENCLOSURE

Occasionally, cooling towers are located inside architectural enclosures for aesthetic reasons. Although AV Series towers adapt well to enclosures, the designer must realize the potential impact of a poorly arranged enclosure on the tower's performance and operation. The designer must take care to provide generous air inlet paths, and the tower's fan cylinder discharge height should not be lower than the elevation of the top of the enclosure. Obtain a copy of *Marley Technical Report #H-004 "External Influences on Cooling Tower Performance"* from your Marley sales representative.

As suggested in the aforementioned Technical Report, it may also be advisable to specify a design wet-bulb temperature 1°C higher than normal to compensate for potential recirculation initiated by the enclosure. You'll benefit from discussing your project with your Marley sales representative.

## SYSTEM CLEANLINESS

Cooling towers are very effective air washers. Atmospheric dust able to pass through the relatively small louver openings will enter the circulating water system. Increased concentrations can intensify system maintenance by clogging screens and strainers—and smaller particulates can coat system heat transfer surfaces. In areas of low flow velocity—such as the cold water basin—sedimentary deposits can provide a breeding ground for bacteria.

In areas prone to dust and sedimentation, you should consider installing some means for keeping the cold water basin clean. Typical devices include side stream filters and a variety of filtration media.

## WATER TREATMENT

To control the buildup of dissolved solids resulting from water evaporation, as well as airborne impurities and biological contaminants including Legionella, an effective consistent water treatment program is required. Simple blowdown may be adequate to control corrosion and scale, but biological contamination can only be controlled with biocides.

An acceptable water treatment program must be compatible with the variety of materials incorporated in a cooling tower—ideally the pH of the circulating water should fall between 6.5 and 8.0. Batch feeding of chemicals directly into the cooling tower is not a good practice since localized damage to the tower is possible. Specific startup instructions and additional water quality recommendations can be found in the AV Series User Manual which accompanies the tower and also is available from your local Marley sales representative. For complete water treatment recommendations, consult a competent, qualified water treatment supplier.

### ▲ CAUTION

The cooling tower must be located at such distance and direction to avoid the possibility of contaminated discharge air being drawn into building fresh air intake ducts. The purchaser should obtain the services of a Licensed Professional Engineer or Registered Architect to certify that the location of the cooling tower is in compliance with applicable air pollution, fire and clean air codes.

### TYPICAL APPLICATIONS

The AV cooling tower can be used in normal applications requiring cold water for the dissipation of heat. This includes condenser water cooling for air conditioning, refrigeration, and thermal storage systems, as well as their utilization for free-cooling in all of those systems. They are also used in the cooling of jacket water for engines and air compressors, and are widely applied to dissipate waste heat in a variety of industrial and manufacturing processes.

Choosing the all stainless steel construction option, the AV can be confidently applied in unusually corrosive processes and operating environments. However, no single product line can answer all problems, and selective judgement should be exercised in the following situations

### APPLICATIONS REQUIRING ALTERNATIVE COOLING TOWER SELECTIONS

Certain types of applications are incompatible with any cooling tower with PVC film fill—whether an AV or other manufacturer's cooling tower of similar design. PVC is subject to distortion in high water temperatures, and the narrow passages typical of film-type fill are easily clogged by turbid or debris-laden water. Some of the applications, which call for alternative tower designs are:

- Ethylene glycol content—can plug fill passages as slime and algae accumulate to feed on the available organic materials.
- Fatty acid content—found in processes such as soap and detergent manufacturing and some food processing, fatty acids pose a serious threat for plugging fill passages.
- Particulate carry over—often found in steel mills and cement plants, can both cause fill plugging, and can build up to potentially damaging levels on tower structure.
- Pulp carry over—typical of the paper industry and food processing where vacuum pumps or barometric condensers are used. Causes fill plugging which may be intensified by algae.

### ALTERNATIVE SELECTIONS

In addition to the AV Series, we offer a full scope of Marley products in various designs and capacities to meet the special demands of specific applications.

[spxcooling.com](http://spxcooling.com)—visit us on the web for a complete list of products, services, publications and to find your nearest sales representative.

### CORROSION RESISTANCE

- QuadraFlow®—fiberglass and stainless steel construction assures long service life in virtually any environment. Five-year full product warranty. Efficient PVC film fill. Uniquely different and architecturally attractive.
- Sigma™—available in wood, fiberglass, HDG steel or stainless steel structure. Field-erected for medium to large projects. Available in a wide range of sizes. Efficient PVC film fill.

### SPLASH FILL

- NC® alpha—available in galvanized steel and stainless steel, with splash-type fill. Excellent in “dirty water” applications.

Specifications	Specification Value
<p><b>1.0 Base:</b></p> <p><b>1.1</b> Provide an induced draft, crossflow type, factory assembled, film fill, industrial duty, galvanized steel cooling tower situated as shown on the plans. The limiting overall dimensions of the tower shall be _____ wide, _____ long, and _____ high to the top of the fan guard. Total operating power of all fans shall not exceed _____ kW, consisting of ____ @ ____ kW motor(s). Tower shall be similar and equal in all respects to Marley Model _____.</p> <p><b>1.2</b> The cooling tower shall be designed for quiet operation, and shall produce an overall level of sound not higher than _____ dB(A) measured at _____ m from the location: _____. Sound levels shall be measured with a Type 1 (precision) system and in full conformance with ATC-128 test code published by the Cooling Technology Institute (CTI). The measurement system shall have a real-time frequency analyzer and separate microphones with an overall tolerance +/- 3 dB. All low sound options shall be CTI Certified for thermal performance.</p>	<p>■ Your specification base establishes the type, configuration, base material, and physical limitations of the cooling tower to be quoted. During the planning and layout stages of your project, you will have focused your attention on a cooling tower selection that fits your space allotment, and whose power usage is acceptable. Limitations on physical size and total operating horsepower avoid the introduction of unforeseen operational and site-related influences. Specifying the number of cells, and the maximum fan hp/cell will work to your advantage.</p> <p>The benefit of crossflow towers is that they are inherently easy to operate, access, and maintain. Unlike counterflow towers, they have a spacious, full height plenum for easy access to all of the tower's internal components, and the water distribution system is readily open to view and cleaning.</p> <p>If your preference is for a stainless steel tower, or if your water or air quality suggests that the use of stainless steel is prudent, see stainless steel options on page 28.</p>

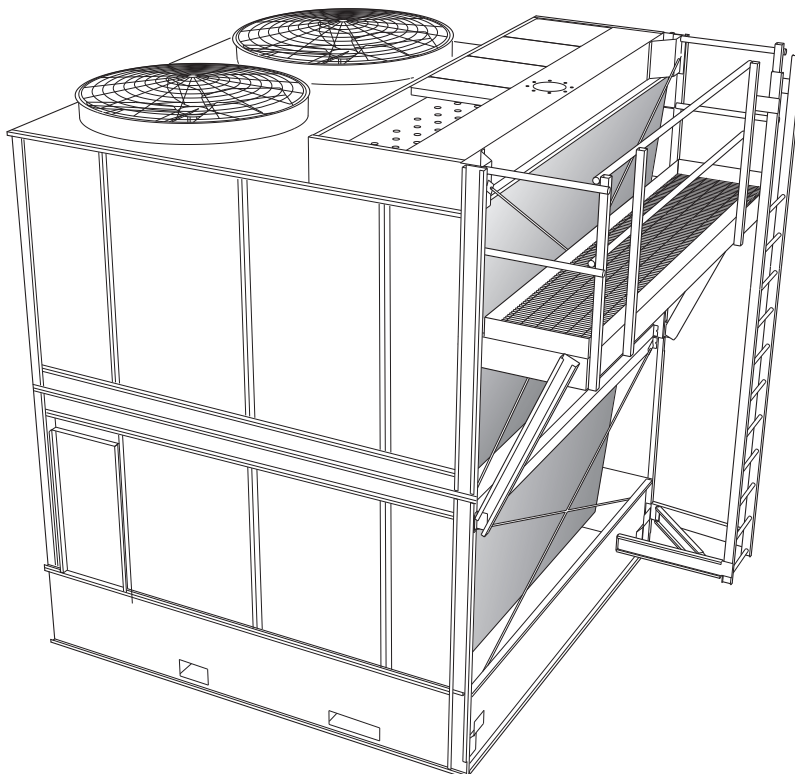

Ladder and access platform are optional accessories. See Page 34 for specification wording.

The ladder can be located on either end of the platform by simple field rearrangement of handrails and posts.

Specifications	Specification Value
<p><b>2.0 Thermal Performance:</b></p> <p><b>2.1</b> The tower shall be capable of cooling _____ m<sup>3</sup>/hr of water from _____ °C to _____ °C at a design entering air wet-bulb temperature of _____ °C, and its thermal rating shall be Certified by the Cooling Technologies Institute.</p> <p><b>3.0 Performance Warranty:</b></p> <p><b>3.1</b> CTI Certification notwithstanding, the cooling tower manufacturer shall guarantee that the tower supplied will meet the specified performance conditions when the tower is installed according to Plans. If, because of a suspected thermal performance deficiency, the Owner chooses to conduct an on-site thermal performance test under the supervision of a qualified, disinterested third party in accordance with CTI or ASME standards during the first year of operation; and if the tower fails to perform within the limits of test tolerance; then the cooling tower manufacturer will pay for the cost of the test and will make such corrections as are appropriate and agreeable to the Owner to compensate for the performance deficiency.</p> <p><b>4.0 Design Loading:</b></p> <p><b>4.1</b> The structure and anchorage shall be designed to withstand a wind load of 244 kg/m<sup>2</sup> while operating, based on International Building Code ASCE7-10, as well as a .3g seismic load. The tower shall be designed to withstand shipping and hoisting loads of 2g horizontal and 3g vertical. Handrails, where specified, shall be capable of withstanding a 890 N concentrated live load in any direction, and shall be designed in accordance with OSHA guidelines. Fork lift slots shall be provided in the basin side supports to allow handling of the tower at grade level.</p> <p><b>4.2</b> The tower shall be structurally capable of being supported at the four outer corners of the tower cell. Alternatively, the tower manufacturer shall provide supporting steel to adapt tower to be supported at four outer corners.</p>	<div style="display: flex; align-items: center;"> <div style="flex: 1;"> <ul style="list-style-type: none"> <li>■ CTI Certification means that the tower has been tested under operating conditions and found to perform as rated by the manufacturer under those circumstances. It assures the buyer that the tower is not intentionally or inadvertently undersized by the manufacturer.</li>   <li>■ However, CTI certification alone is not sufficient to assure you that the tower will perform satisfactorily in your situation. Certification is established under relatively controlled conditions, and towers seldom operate under such ideal circumstances. They are affected by nearby structures, machinery, enclosures, effluent from other towers, etc. Responsible and knowledgeable bidders will take such site-specific effects into consideration in selecting the tower—but the specifier must insist by the written specification that the designer/manufacturer guarantee this “real world” performance. Any reluctance on the part of the bidder should cause you some concern.</li>   <li>■ The design wind and seismic loads at the left are the minimum allowables for any model in the line under accepted design standards. Some models can withstand greater loads. If your application requires higher loads, consult your Marley sales representative. These standards give you assurance that the tower can be shipped, handled, hoisted and ultimately operated in a normal cooling tower environment.</li> </ul> </div> <div style="flex: 0.5; text-align: center;">  </div> </div>

Specifications	Specification Value
----------------	---------------------

**5.0 Construction:**

**5.1** Except where otherwise specified, all components of the cooling tower shall be fabricated of heavy-gauge steel, protected against corrosion by Z725 galvanizing. The tower shall be capable of withstanding water having a pH of 6.5 to 8.0; a chloride content (NaCl) up to 500 mg/l; a sulfate content (SO<sub>4</sub>) up to 250 mg/l; a calcium content (CaCO<sub>3</sub>) up to 500 mg/l; and silica (SiO<sub>2</sub>) up to 150 mg/l; The circulating water shall contain no oil, grease, fatty acids, or organic solvents. Fiberglass casing, polyurethane barriers, and thermosetting hybrids and the components that are adhered to the sheet metal surface, shall be considered non-recyclable and not allowed.

**5.2** The specifications, as written, are intended to indicate those materials that will be capable of withstanding the above water quality in continuing service, as well as the loads described in paragraph 4.1. They are to be regarded as minimum requirements. Where component materials peculiar to individual tower designs are not specified, the manufacturers shall take the above water quality and load carrying capabilities into account in the selection of their materials of manufacture.

■ In the history of cooling towers, no other coating for carbon steel has exhibited the success and longevity of galvanization in exposure to the normal cooling tower water quality defined at left. No paints or electrostatically applied coatings, however exotic they may be, can approach galvanization's history of success.

Except for those unusual operating situations where the circulating water may be so laden with suspended solids, algae, fatty acids, product fibers, active organisms reflected in BOD, and the like that plugging of the fill is a probability, reasonable attention to the construction materials and/or their coatings is all that is normally required.

If your preference is for a stainless steel tower, or if your water or air quality suggests that the use of stainless steel is prudent, see stainless steel options on page 28.



*Factory Assembly*

Specifications	Specification Value
<p><b>6.0 Mechanical Equipment:</b></p>	
<p><b>6.1</b> Fan(s) shall be propeller type, incorporating heavy duty aluminum alloy blades attached to galvanized hubs with stainless steel U-bolts and hardware. Blades shall be attached to hubs with stainless steel hardware, and shall be individually adjustable. Fan(s) shall be driven through an industrial grade system of V-belts, pulleys, and tapered roller bearings. Bearings shall be rated at 50,000 hours, or greater.</p>	<ul style="list-style-type: none"> <li>■ Propeller-type fans require only half the operating hp of blower-type fans. However, they should be readily adjustable to permit compensation for job site conditions that may tend to overload the motor. The fans of one manufacturer require the purchase of special positioners for each increment of fan blade pitch.</li> </ul> <p>Unless otherwise specified, motor speed will be 1500 RPM in 50. If you prefer the operating flexibility of two-speed operation, please specify the RPM to be 1500/750 in 50 Hertz. Incidentally, two speed motors are a far better choice than separate “pony” motors which simply double the problems indicated above.</p>
<p><b>6.2</b> Motor(s) shall be ____ hp maximum, NEMA Premium Efficiency, TEFC, 1.15 service factor, variable torque, inverter duty and insulated for cooling tower duty. Speed and electrical characteristics shall be _____ RPM, single-winding, 3 phase, ____ hertz, ____ volts. Motor shall operate shaft-vertical position for belt drive towers and in the shaft-horizontal position for geardrive towers. Nameplate power shall not be exceeded at design operation. TEAO motors are not acceptable.</p>	<p>If your preference is for a stainless steel tower, or if your water or air quality suggests that the use of stainless steel is prudent, see stainless steel options on</p>
<p><b>6.3</b> The fan and fan drive assembly for each cell shall be supported by a rigid, welded, hot dip galvanized steel structural support that resists misalignment. The mechanical equipment assembly shall be warranted against any failure caused by defects in materials and workmanship for no less than five (5) years following the date of tower shipment. This warranty is limited to the fan, fan shaft, bearings, and mechanical equipment support. The motor, motor components, sheaves and belt(s) are warranted by their manufacturer.</p>	



Specifications	Specification Value
----------------	---------------------

**7.0 Fill, Louvers, and Drift Eliminators:**

**7.1** Fill shall be film-type, thermoformed of PVC, with louvers and eliminators formed as part of each fill sheet. Fill shall be suspended from hot-dip galvanized structural tubing supported from the tower structure, and shall be elevated above the floor of the cold water basin to facilitate cleaning. The air inlet face of the tower shall be free of water splash-out.

**7.2** Drift eliminators shall be PVC, triple-pass, and shall limit drift losses to no more than 0.005% of the design gpm flow rate.

page 28.

■ Louvers integral with the fill keep the flowing water within the confines of the fill. The separate external louvers used by others permit water to escape the fill and form ice or produce an unsightly situation adjacent to the tower. If you plan to use your tower in the wintertime, particularly for free cooling, integral louvers will put your operating concerns to rest.

■ Drift rate varies with design water loading and air rate, as well as drift eliminator depth and number of directional changes. A drift rate of 0.001% is readily available on many standard models. If a lower rate is required, please discuss with your Marley sales representative.

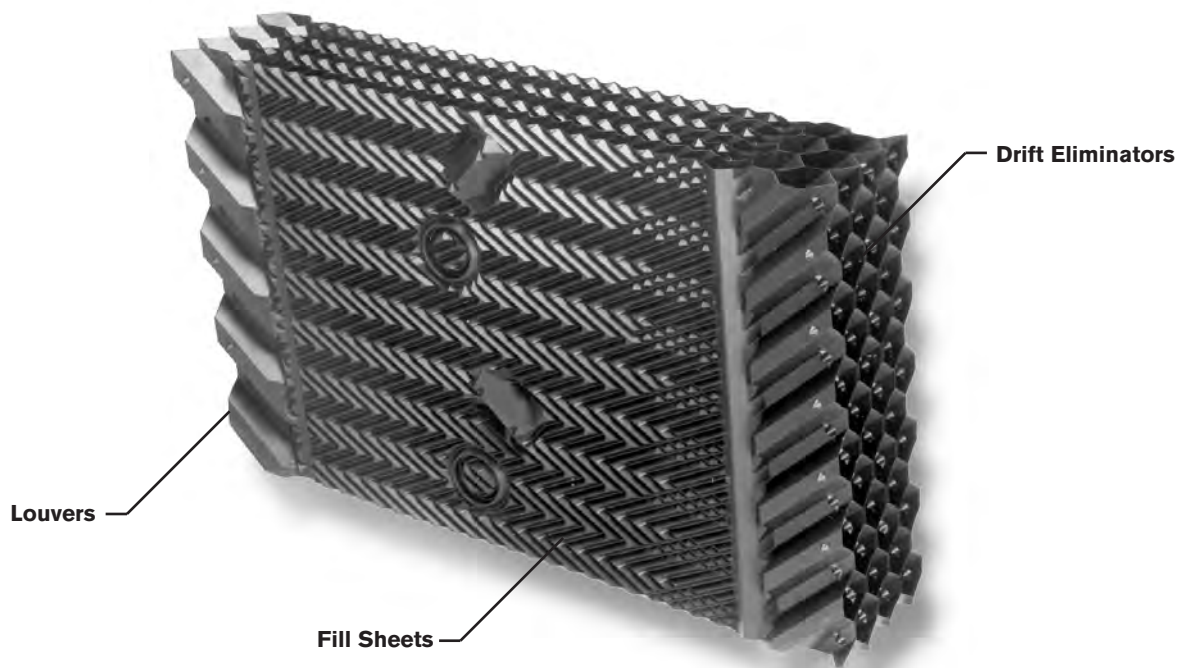
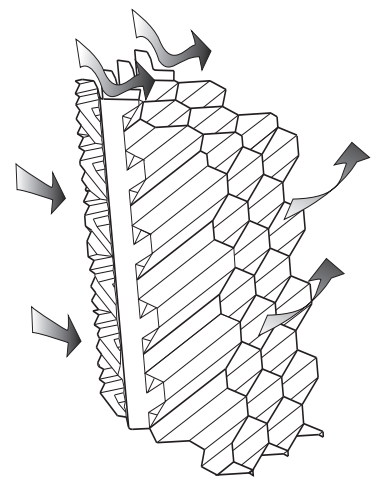

Specifications	Specification Value
----------------	---------------------

**8.0 Hot Water Distribution System:**

**8.1** An open basin above the bank of fill shall receive hot water piped to each cell of the tower. These distribution basins shall be installed and sealed at the factory with bolted connections. Tap screws shall not be allowed. The basin shall , and shall be equipped with removable, galvanized steel covers to keep out leaves and debris, and to retard the growth of algae. The water distribution system shall be accessible and maintainable during tower fan and water operation.

**8.2** The basin shall include an inlet hole and bolt circle to accept a 125# flange connection per ANSI B16.1. Removable, interchangeable polypropylene nozzles installed in the floor of these basins shall provide full coverage of the fill by gravity flow.

**9.0 Casing, Fan Deck and Fan Guard:**

**9.1** The casing and fan deck shall be heavy-gauge galvanized steel, and shall be capable of withstanding the loads described in paragraph 4.1. The top of the fan cylinder shall be equipped with a conical, non-sagging, removable fan guard, fabricated of welded 8mm and 7 gauge rods, and hot-dip galvanized after fabrication.

**10.0 Access:**

**10.1** Large galvanized steel access doors 584mm wide and a minimum of 1321mm high shall be located in both endwalls for entry into the cold water basin and fan plenum area. Access doors shall be operable from inside as well as outside the tower

■ Gravity-flow distribution basins are a feature of crossflow type towers, resulting in operating pump heads of from 300 to 600 cm less than that encountered in counterflow towers with pressurized spray systems. Also, these basins are out where they can be easily inspected—even maintained—while the tower is in operation. Spray systems of counterflow towers, sandwiched between the top of the fill and the drift eliminators, are extremely awkward to access and maintain.

If your preference is for a stainless steel tower, or if your water or air quality suggests that the use of stainless steel is prudent, see stainless steel options on page 28.



■ The access doors on competitive towers may be 450mm wide or smaller, which is unreasonably small for a human being. Specifying the size of the door will cause those bidders to take exception, alerting you to a potential maintenance headache. Two doors are standard on all towers so that access between cells of multicell towers is assured.

Specifications	Specification Value
<p><b>11.0 Cold Water Collection Basin:</b></p>	
<p><b>11.1</b> The collection basin shall be Z725 galvanized steel and assembled with bolted connections. Tap screws shall not be allowed. The cold water basin shall be heavy-gauge galvanized steel, and The basins shall include the number and type of suction connections required to accommodate the outflow piping system shown on the Plans. Suction connections shall be equipped with galvanized debris screens. A factory-installed, float-operated, mechanical makeup valve shall be included. A 3" diameter drain and a 4" diameter overflow shall be provided in each cell of the tower. The basin shall include a depressed section into which accumulated silt can be flushed to permit cleaning. The basin floor adjacent to the depressed section shall slope toward the depressed section to prevent buildup of silt under the fill area. Towers of more than one cell shall include flumes for flow and equalization between cells.</p>	<ul style="list-style-type: none"> <li>■ Choose from side suctions and bottom outlets to accommodate a significant variety of piping schemes. Unless so specified, the tower you may be asked to approve may only be available with one type of suction connection, requiring you to redesign your piping layout.</li> </ul> <p>If your preference is for a stainless steel tower, or if your water or air quality suggests that the use of stainless steel is prudent, see stainless steel options</p>

Specifications	Specification Value
----------------	---------------------

**Stainless Steel Options**

**All Stainless Cooling Tower**

**5.1:** *Replace paragraph 5.1 with the following:* Except where otherwise specified, all components of the cooling tower shall be fabricated of 301L stainless steel. The tower shall be capable of withstanding water having a chloride content (NaCl) up to 750 mg/L; a sulfate content (SO<sub>4</sub>) up to 1200 mg/L; a calcium content (CaCO<sub>3</sub>) up to 800 mg/L; and silica (SiO<sub>2</sub>) up to 150 mg/L. The circulating water shall contain no oil, grease, fatty acids, or organic solvents. Fiberglass casing, polyurethane barriers, and thermosetting hybrids and the components that are adhered to the sheet metal surface, shall be considered non-recyclable and not allowed.

**Stainless Steel Collection Basin:**

**11.1:** *Replace paragraph 11.1 with the following:* The collection basin shall be welded 301L stainless steel construction. Only low-carbon stainless steel alloys will be accepted in order to minimize the risk of intergranular corrosion in the weld zones. The basin shall include the number and type of suction connections required to accommodate the outflow piping system shown on the plans. Suction connections shall be equipped with stainless steel debris screens. A factory-installed, float-operated, mechanical make-up valve shall be included. An overflow and drain connection shall be provided in each cell of the cooling tower. The basin floor shall slope toward the drain to allow complete flush out of debris and silt that may accumulate. Towers of more than one cell shall include a method for flow and equalization between cells. The basin shall be accessible and maintainable while water is circulating. All steel items that project into the basin shall also be made of stainless steel.

- Where water quality falls outside the limits indicated in Paragraph 5.1, an all-stainless tower is worthy of your consideration.

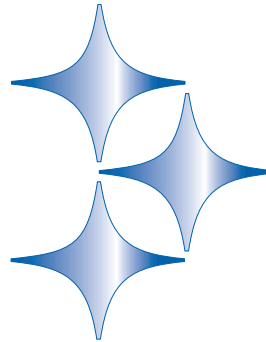

- The cold water basin is the only part of the tower that is subject to periods of stagnant water, concentrated with treatment chemicals and customary contaminants. It is also the most expensive and difficult part of any tower to repair or replace. For these reasons, many customers—particularly those who are replacing older towers—choose to specify stainless steel cold water basins.

Also, see the notes on page 27 regarding the standard Cold Water Collection Basin. They apply equally well to the stainless steel basin.

Specifications	Specification Value
----------------	---------------------

**Stainless Steel Distribution Basin:**

**8.1:** *Replace paragraph 8.1 with the following:* An open 301L stainless steel basin shall receive hot water piped to each cell of the tower. These basin components shall be installed and sealed at the factory and assembled with bolted connections. Tap screws shall not be acceptable due to their potential to develop leaks. The basins shall be equipped with removable, stainless steel covers capable of withstanding the loads described in paragraph 4.1. All components of these basins, with the exception of the nozzles, shall be stainless steel. The water distribution system shall be accessible and maintainable during tower fan and water operation.

**Control Options**

**Fan Motor Starter Control Panel:**

**6.4** *AAdd the following paragraph to the Mechanical Equipment section:* Each cell of the cooling tower shall be equipped with a UL / CUL 508 listed control panel in an IP14 or IP56 outdoor enclosure capable of controlling single-speed or two-speed motors as required, and designed specifically for cooling tower applications. The panel shall include a main circuit breaker with an external operating handle, lockable in the off position for safety. Full voltage non-reversing magnetic starter shall be controlled with a thermostatic or solid-state temperature controller. Door mounted selector switches shall be provided to enable automatic or manual control and wired for 120VAC control. Control circuit to be wired out to terminal blocks for field connection to a remote vibration switch, overload trip alarms and remote temperature control devices. The temperature controller shall be adjustable for the required cold-water temperature. If a thermostatic controller is used it shall be mounted on the side of the tower with the temperature sensing bulb installed in the cold-water basin using a suspension mounting bracket. If a solid-state temperature controller is used the controller will be door mounted on the control panel. The solid state temperature controller will display two temperatures, one for outgoing water and the other for set point. Water temperature input shall



on page 28.

- The corrosion potential of contaminated water increases with temperature—and these basins see the hottest water in the tower. If your design hot water temperature is over 52°C, or if your operating system can produce excursions beyond that point, you would be well advised to consider this option.

It would also be advisable to change the fill support tubes in Para. 7.1 from galvanized structural tubing to 300 stainless steel structural tubing. See notes regarding Section 8.0 on page 26.

- If it is your opinion that the control system for the cooling tower be part of the tower manufacturer's responsibility, we are in wholehearted agreement with you. Who better to determine the most efficient mode and manner of a cooling tower's operation—and to apply a system most compatible with it—than the designer and manufacturer of the cooling tower?

Marley variable speed drives are also available for enhanced temperature control, energy management and mechanical equipment longevity. See specifications on page 31.



Specifications	Specification Value
----------------	---------------------

be obtained using a three-wire RTD with dry well in the outlet water piping and wired back to the solid-state temperature controller in the control panel.

**Terminal Box:**

6.4 *Add the following paragraph in the Mechanical Equipment section:* A factory installed terminal box shall be furnished and mounted to the outside of the tower where applicable. The fan motor and optional components—including the vibration switch and water level probes—shall be factory wired to terminal points inside the terminal box. Optional tower components which ship loose, including the oil level switch and immersion heaters shall be field wired to the terminal box. Enclosure shall be IP14 or IP56 with hinged and lockable door meeting UL and CSA standards. Terminal box shall include lockable stainless steel snap-latch door fasteners, terminal blocks marked with wire numbers, sub-pan and a wiring diagram. Complete assembly shall be built to UL 508A standards. Conduit entry and exit points shall be the bottom of the enclosure preventing water collection in the enclosure.

**Vibration Limit Switch:**

6.5 *Add the following paragraph in the Mechanical Equipment section:* A vibration limit switch in a NEMA 4X housing shall be installed on the mechanical equipment support and wired to the shut-down circuit of the fan motor starter or VFD. The purpose of this switch will be to interrupt control power voltage to a safety circuit in the event of excessive vibration causing the starter or VFD equipment to de-energize the motor. It shall be adjustable for sensitivity and include a means to reset the switch.

■ The Marley Terminal Box simplifies all electrical connections to the cooling tower motor and optional control accessories.

- Eliminates wiring errors in the field
- Reduces field wiring labor and materials
- Provides an external access location to internal cooling tower wiring
- IP56 fiberglass enclosure suitable for corrosive applications
- Terminal points are well identified
- UL 508 assembly

■ Unless specified otherwise, a IMI Sensors mechanical vibration switch will be provided. The requirement for manual reset assures that the cooling tower will be visited to determine the cause of excessive vibration.

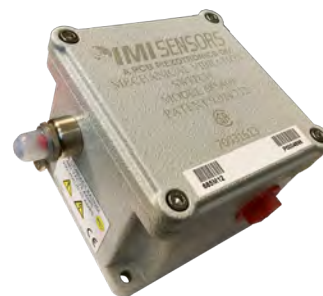

**Specifications**

**Basin Heaters:**

11.2 *Add the following paragraph in the Cold Water Basin section:* Provide a system of electric immersion heaters and controls for each cell of the tower to prevent freezing of water in the collection basin during periods of shutdown. The system shall consist of one or more stainless steel electric immersion heaters installed in threaded couplings provided in the side of the basin. A IP56 enclosure shall house a magnetic contactor to energize heaters; a transformer to provide 24 volt control circuit power; and a solid state circuit board for temperature and low water cutoff. A control probe shall be located in the basin to monitor water level and temperature. The system shall be capable of maintaining 5°C water temperature at an ambient air temperature of \_\_\_ °C.

**Fan Motor Variable Speed Drive:**

**ACH550 VFD System**

6.5 *Add the following paragraph in the Mechanical Equipment section:* A complete UL listed Variable Speed Drive system in a IP10 indoor, IP52 indoor or IP14 outdoor enclosure shall be provided. The VFD shall use PWM technology with IGBT switching. VFD output switching signal shall be programmed to not cause mechanical vibration issues with backlash in gearbox teeth or vibration issues associated with long driveshafts. The VFD shall be programmed for variable torque applications and shall catch a fan spinning in the forward or reverse direction without tripping. VFD panel construction shall include a main disconnect with short circuit and thermal overload protection with external operating handle, lockable in the off position for lock-out tag-out safety procedures. A service switch directly ahead of the VFD shall be provided for voltage isolation during VFD maintenance. An integrated full voltage non-reversing bypass starter shall be furnished allowing fan motor operation if VFD has failed. The VFD system shall receive a speed reference signal from the building management system monitoring the tower cold-water temperature. As an option to receiving the speed reference signal from a building management system, the drive must have the capability to receive a 4-20 mA temperature signal from an RTD

**Specification Value**

■ The Marley basin heater components described at left represent our recommendation for a reliable automatic system for the prevention of basin freezing. They are normally shipped separately for installation at the jobsite by the installing contractor. When purchased in conjunction with the enhanced Control System option, however, they are customarily factory-mounted and tested.



**When zinc ions are present in basin water, copper immersion heaters must not be used. Insist upon stainless steel.**

The ambient air temperature that you insert in the specifications should be the lowest 1% level of winter temperature prevalent at site.

■ Marley Variable Speed Drive systems are designed to combine absolute temperature control with ideal energy management. The cooling tower user selects a cold water temperature and the drive system will vary the fan speed to maintain that temperature. Precise temperature control is accomplished with far less stress to the mechanical equipment components. The improved energy management provides energy savings to the user.

Motors operated on a VFD shall carry a service factor of 1.0. When operating on a VFD, the drive parameters should be programmed to limit the current to motor nameplate hp. Adjust the Motor specification accordingly.

Applications requiring a cable distance between VFD and motor of over 100 feet requires a separate DV/DT motor filter to be installed and wired at the drive. This filter protects the motor from damaging high voltage spikes on the motor windings, inherent with long lead runs.



Specifications	Specification Value
----------------	---------------------

transmitter. The VFD shall have an internal PI regulator to modulate fan speed maintaining set point temperature. The drive's panel shall display the set-point temperature and cold-water temperature on two separate lines. The bypass shall include a complete magnetic bypass circuit with the capability to isolate the VFD when in the bypass mode. Transfer to the bypass mode shall be manual in the event of VFD failure. Once the motor is transferred to the bypass circuit the fan motor will run at constant full speed. Operator controls shall be mounted on the front of the enclosure and shall consist of Start and Stop control, Bypass/VFD selection, Auto/Manual selections and manual speed control. To prevent heating problems in the cooling tower fan motor the VFD system shall de-energize the motor once 25% motor speed is reached and cooling is no longer required. The cooling tower manufacturer shall supply VFD start-up assistance.

**Single-Point Power Connection:**

6.6 *Add the following paragraph in the Mechanical Equipment section:* Each cell of the cooling tower shall be equipped with a UL/CUL 508 listed control panel in a IP14 or IP56 outdoor enclosure. The panel shall accommodate a single source power supply feeder and include electrical circuits and components to power and control all electrical cooling tower components for a single cell. The panel shall include a main circuit breaker with an external operating handle, lockable in the off position for safety. Controls integrated into the panel shall include a fan motor starter, basin heater controls and water level controls. In the event a VFD is furnished for the fan, a feeder breaker in the panel to a remote mounted VFD shall be provided.



- A main circuit breaker disconnect provides a true single point power connection for cooling tower controls. Contractor connects a single power source and the panel provides power feeds, controls and voltages for tower controls. Typically each cell of a tower requires one SPPC panel.





**Specifications**

**Specification Value**

**Motor Sequencer with RTD:**

6.4 *Add the following paragraph to the Mechanical Equipment section:* A complete system including a sequencer control panel with temperature RTD and a one-speed or two-speed starter panel for each cell shall be provided. The sequencer shall be furnished to automatically stage multiple fans in a cooling tower lineup. Staging shall be based on a programmed set point temperature and the cold-water discharge representing the total cold water temperature leaving a tower. Enclosure shall be either IP52 indoor or IP56 outdoor with hinged and lockable door meeting UL508 or CUL508 standards. Sequencer operating two speed motors may be configured to cycle through as LO1 – LO2 – LO3 – HI1 – HI2 – HI3 as a default setting or optional setting as LO1 – HI1 – LO2 – HI2 – LO3 – HI3. Indicator lights used to display which cells are energized and at which speed shall be provided on the enclosure door. Indication of running status of each cell and speed shall be brought out to user terminal blocks for remote monitoring. An optional remote set point control via a 4-20mA signal shall be available to remotely control the set point value.

**Water Level Control System:**

11.2 *Add the following paragraph to the Cold Water Basin section:* Provide a water level control system including a IP56 control panel, water level probes and probe stilling chamber. The control system shall monitor the water level in the cold-water basin to determine level events used for cold-water make-up, high and low alarms or pump shut down. The control panel shall use electromechanical relays providing power for the make-up solenoid and electrical contacts for alarm and pump shutdown control circuits. Probes shall be contained in a vertical stilling chamber to stabilize the water in the cold-water basin. Probes shall have replaceable stainless steel tips and level height shall be field adjustable.

- Marley sequencer controls help extend the life of the fan motors with automatic lead stage rotation. The sequencing controllers prevent the same motor from always starting first in the normal sequence of operation. Every 24 hours a different motor becomes the lead stage, equalizing the wear on all motors.

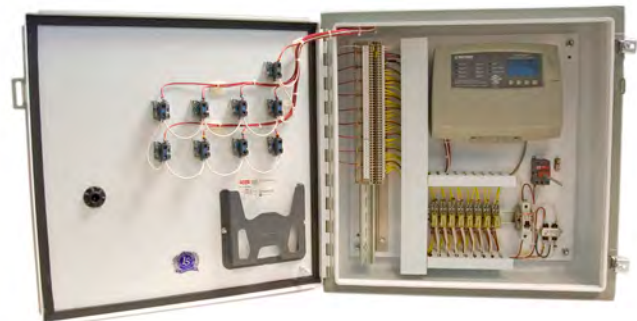

- Solid-state liquid level controls provide you with state-of-the-art systems to control and monitor the water level in your cooling tower collection basin. Relays operating in conjunction with suspended stainless steel electrode probes monitor basin water levels, providing simple solenoid-valve water make-up or discrete on/off signals to more sophisticated automation controls. Optional configurations might include make-up along with high and low water level alarm and cutoff, or pump cutoff. Packaged systems including any of these variations are available. Consult your Marley sales representative or download literature num-

Specifications	Specification Value
<p><b>Convenience and Safety Options</b></p>	
<p><b>Hot Water Basin Access Platform:</b></p>	
<p>10.2 <i>Add the following paragraph in the Access section:</i> Provide an external platform near the top of the louver face for access to the hot water distribution system. The platform shall be galvanized steel bar grating, supported by galvanized steel framework attached to the tower. The platform shall be surrounded by a handrail, kneerail, and toeboard. A permanently attached 457mm wide aluminum ladder with 76mm I-beam side rails and 32mm diameter serrated rungs shall extend from the base of the tower to the top of the handrail.</p>	<p>ber ACC-NC-9 from <a href="http://spxcooling.com">spxcooling.com</a> for additional information.</p> <ul style="list-style-type: none"> <li>■ Periodic inspection and maintenance of a cooling tower distribution system is fundamental to preserving maximum cooling system efficiency. All cooling towers—crossflow or counterflow—are subject to clogging to varying degrees by waterborne contaminants such as pipe scale and sediment. Therefore, safe and easy access to these components is of significant value to the operator.</li> </ul>  <p>Access can be provided in a number of ways, including portable ladders or scaffolding, but for maximum safety and convenience, a factory installed Marley access platform with guardrails makes this task as safe and user-friendly as possible. Further, its location on the side of the tower does not add to the height of the unit, preserving architectural integrity. See graphic, Page 21. It also saves the owner time and money, in that maintenance personnel may devote their time to inspection rather than searching for ladders or erection of portable scaffolding.</p>
<p><b>Hot Water Basin Guardrail System:</b></p>	
<p>10.2 <i>Add the following paragraph in the Access section:</i> The area surrounding the hot water basin of the tower shall be equipped with a guardrail complete with knee rail and toeboard, designed according to OSHA guidelines and factory welded into subassemblies for ease of field installation. Posts, top rails and knee rails shall be 38mm square tubing. The guardrail assembly shall be hot dipped galvanized after welding and capable of withstanding a 890N concentrated live load in any direction. Posts shall be spaced on centers of 2400mm or less. A 460mm wide aluminum ladder with 76mm I-beam side rails and 32mm diameter rungs shall be permanently attached to the end wall casing of the tower, rising from the base of the tower to the top of the guardrail.</p>	
<p><b>Ladder Extension:</b></p>	
<p>10.2 <i>Add the following to the end of the Hot Water Basin Access Platform paragraph:</i> Provide a ladder extension for connection to the foot of the external ladder. This extension shall be long enough to rise from the roof (grade) level. The installing contractor shall be responsible for cutting the ladder to length; attaching it to the foot of the tower ladder; and anchoring it at its base.</p>	<ul style="list-style-type: none"> <li>■ Many towers are installed such that the base of the tower is 610 mm or more above the roof or grade level. This makes it difficult to get up to the foot of the</li> </ul>

Specifications	Specification Value
<p><b>Ladder Safety Cage:</b></p> <p>10.2 <i>Add the following to the end of the Hot Water Basin Access Platform paragraph:</i> A heavy gauge galvanized steel safety cage shall surround the ladder, extending from a point 2135 mm to 2440 mm above the foot of the ladder to the top of the distribution basin access platform handrail.</p> <p><b>Ladder Safety Gate:</b></p> <p>10.2 <i>Add the following to the end of paragraph 10.2:</i> A steel, self-closing gate shall be provided at the guardrail level of the ladder.</p> <p><b>Mechanical Equipment Access Platform:</b></p> <p><i>Available only on AV6817 and AV6819 models.</i></p> <p>10.3 <i>Add the following paragraph in the Access section:</i> Provide an internal platform approximately 2135 mm below the level of the fan for access to the mechanical equipment. The platform shall be galvanized steel bar grating, supported by galvanized steel framework attached to the tower. The platform shall be surrounded by a handrail and kneerail. A permanently attached 457 mm wide aluminum ladder with 76 mm I-beam side rails and 32mm diameter serrated rungs shall extend from the cold water basin to the top of the handrail.</p> <p><b>Access Door Platform:</b></p> <p>10.2 <i>Add the following paragraph in the Access section:</i> There shall be an access platform at the base of the tower extending from the vertical ladder to the access door. The platform shall be surrounded by an OSHA compliant guardrail system welded into subassemblies for ease of installation. The walking surface of the platform shall be perforated to provide a non-slip surface for personnel safety.</p>	<p>attached ladder. The ladder extension alleviates this problem. Marley ladder extensions are available in standard 1524 mm and 3353 mm length</p> <ul style="list-style-type: none"> <li>■ To meet OSHA guidelines, towers whose distribution basin access platforms are 6100 mm or more above roof or grade, and which are equipped with external ladders, should have safety cages surrounding the ladders.</li> </ul> <ul style="list-style-type: none"> <li>■ A galvanized steel self-closing gate located at the guardrail level of the fan deck, exterior motor access platform and access door platform. Stainless steel is available with the stainless guardrail option.</li> </ul> <ul style="list-style-type: none"> <li>■ Periodic inspection and maintenance of cooling tower fans, motors and other rotating equipment is fundamental to preserving maximum cooling system efficiency. All mechanical draft cooling towers—forced or induced draft—are subject to vibration and wear. Therefore, safe and easy access to these components for inspection and maintenance is of significant value to the operator.</li> </ul> <p>Access can be provided in a number of ways, including portable ladders or scaffolding, but for maximum safety and convenience, a factory installed Marley access platform with guardrails makes this task as safe and user-friendly as possible. See graphic below. It also saves the owner time and money, in that maintenance personnel may devote their time to inspection rather than search-</p>

Specifications	Specification Value
<p><b>Miscellaneous Options</b></p> <p><b>Fan Cylinder Extensions:</b></p> <p>9.1 <i>Insert the following after the first sentence:</i> Fan cylinder extensions shall be provided to elevate the fan discharge to a height of ___ mm above the top of the standard fan cylinder.</p> <p><b>Equalizer Flume Weir Gates:</b></p> <p>11.3 <i>Add the following paragraph under Cold Water Collection Basin:</i> The interconnecting flume between cells shall be equipped with a removable cover plate to permit the shutdown of one cell for maintenance purposes, or to permit independent cell operation.</p> <p><b>Inlet Flow Control Valve:</b></p> <p>8.3 <i>Add the following paragraph under Hot Water Distribution System:</i> A heavy-duty, industrial grade flow-control valve shall be provided at the inlet to the hot water basin. The valve shall permit both flow balancing on multicell towers and temporary shut-off for maintenance of selected cells. Valve shall have a machined cast iron body, with stainless steel operating stem, and heavy-duty locking handle.</p> <p><b>Variable Water Flow Distribution:</b></p> <p>8.2 <i>Add the following to the end of this paragraph:</i> The water distribution system shall be equipped with a method to operate under variable flow conditions while maintaining a uniform air-side pressure drop through the fill to maximize cooling efficiency and minimize the risk of ice and scale formation in the fill. System must accommodate flow rates down to _____% of design flow.</p>	
	<p>ing for ladders or erection of portable scaffolding.</p> <ul style="list-style-type: none"> <li>■ Extensions are available in 300mm increments to a maximum extension height of 2090mm. Such extensions may be considered necessary in order to elevate the discharge beyond the bounds of an enclosure. Discuss applicability with your local Marley sales representative.</li> <li>■ Where it is your intention to be able to operate other cells of the tower while the flume cover plate is installed, separate outlet connections, float valves, and overflows must be provided for each cell. Likewise, this would require separate sensors and controls for basin heater systems, if installed.</li> <li>■ Marley inlet flow-control valves have been a favorite of users since the 1950s. They remain serviceable for the life of the tower and provide a continuing means of flow-regulation between hot water basins—and between cells of multi-cell towers as well.</li> </ul>
	

Specifications	Specification Value
<p><b>FM Approval:</b></p> <p><i>Available only on multi-cell towers.</i></p> <p><u>5.3</u> <b>Add the following paragraph in the Construction section:</b> For applications of two or more cells, the tower shall be listed in the current FM Approval Guide (approvalguide.com) and conform to the FM Approval Standard for Cooling Towers, Class Number 4930 that is approved for use without sprinkler systems. The tower shall have successfully passed full scale fire testing, static and cyclic wind pressure testing, large missile impact testing (for Zone HM), and structural design evaluation as administered by FM Approvals. A copy of the FM Approval Certificate of Compliance dated November 2013 or later shall be available upon request.</p> <p><b>Air Inlet Screens:</b></p> <p><u>9.1</u> <b>Add the following paragraph to the Casing, Fan Deck and Fan Guard section:</b> The air inlet faces of the tower shall be covered by 25mm mesh hot-dipped galvanized welded wire screens. Screens shall be secured to removable galvanized U-edge frames. Screens shall be designed to permit full access to the cold-water basin by removal of one panel on each air inlet.</p> <p><b>Basin Sweeper Piping:</b></p> <p><u>11.2</u> <b>Add the following paragraph to the Cold Water Collection Basin section:</b> The cold water basin shall be equipped with PVC sweeper piping with plastic nozzles. The piping shall be factory installed under the fill and designed to force all dirt and debris to the depressed section of the collection basin.</p> <p><b>High Wind Load/Seismic Design:</b></p> <p><u>4.1</u> <b>Replace this paragraph with the following:</b> The tower structure, anchorage and all its components shall be designed by licensed structural engineers, employed by the tower manufacturer, per the international building code to withstand a wind load of _____ kg/m<sup>2</sup>, as well as a _____ seismic load. The fan deck and hot-water basin covers shall be designed for 2.4kPa live load or a 91 kg concentrated load. Guardrails, where specified, shall be capable of withstanding a 890N</p>	<ul style="list-style-type: none"> <li>■ This could have a very beneficial effect upon your fire insurance premiums. Towers not able to meet FM requirements may require the inclusion of a fire protection sprinkler system to achieve a comparable level of insurance premium cost. Even if you are not insured by FM, this requirement ensures that each cell will contain any fire that may occur without losing the ability of limited operations and capacity.</li> </ul> <div style="text-align: center;">  </div> <ul style="list-style-type: none"> <li>■ In wooded or windy areas, these screens help to keep leaves or blowing debris out of the cooling tower and circulating water system.</li> <li>■ PVC sweeper piping and nozzles.</li> <li>■ High wind load designs greater than 145 kg/m<sup>2</sup> and up to 490 kg/m<sup>2</sup> are available. It is important to consult the local code official for actual requirements. Some manufacturers may claim their tower is capable but have never had the</li> </ul>



Specifications	Specification Value
----------------	---------------------

concentrated live load in any direction, and shall be designed in accordance with OSHA guidelines.

**Quiet Fan:**

6.1 *Replace paragraph 6.1 with the following:* Quiet Fan(s) shall be propeller type, incorporating a minimum of seven heavy duty aluminum alloy blades attached to galvanized hubs with stainless steel U-bolts and hardware and shall be individually adjustable. Fan(s) shall be driven through an industrial grade system of V-belts, pulleys, and tapered roller bearings. Bearings shall be rated at 50,000 hours, or greater.

**Ultra Quiet Fan:**

6.1 *Replace paragraph 6.1 with the following:* Ultra Quiet Fan(s) shall be propeller-type, incorporating wide-chord acoustic geometry, corrosion and fire resistant marine grade aluminum blades and aluminum hubs. Blades shall be resiliently mounted to fan hub and individually adjustable. Fan blades shall be open cavity with suitable drainage to avoid accumulation of moisture. Foam filled blades are not allowed due to potential moisture contamination of the foam core causing an imbalance of the fan leading to vibration issues. Fan(s) shall be driven through an industrial grade system of V-belts, pulleys, and tapered roller bearings. Bearings shall be rated at 50,000 hours, or greater

design reviewed by a licensed structural engineer. Not requiring this review for high wind and seismic regions can be dangerous to you and the public.

■ The Marley "Quiet Package" includes the affordable Quiet Fan mechanical option, optimized to achieve the lowest possible sound levels while maintaining efficiency. In combination with a Marley Variable Speed Drive, this package is capable of meeting all but the most restrictive sound limitations.

Tip Speed—unlike thermal performance, no certification program exists for sound. While Marley conducts actual sound tests on all its configurations, there are a few ways for the client to ensure they get a quiet tower.

- One is to conduct a field sound test after installation. On-site testing after installation can, however, be inaccurate depending on the environment.
- Another is to conduct a sound test at the factory. However both can be cost prohibitive for smaller applications.
- Specifying fan blade tip speed is one way to physically force the tower selection to be quiet. Tip speed is easily checked by multiplying the fan RPM by the fan circumference at the blade tip ( $\pi$  fan dia). Over 12,000 ft/min is considered high by most people. 10,000-12,000 is considered typical and expected. 8,000-10,000 would be considered low sound. Below 8,000 is difficult to hear above the water noise.

■ For more severe cases requiring the lowest possible fan sound levels, the Marley "Ultra Quiet Fan" option is now available on all AV models. Tower height may increase slightly—obtain current sales drawings from your Marley sales representative for accurate dimensions.





---

**SPX COOLING TECHNOLOGIES UK LTD**

3 KNIGHTSBRIDGE PARK, WAINWRIGHT ROAD  
WORCESTER WR4 9FA UK  
44 1905 750 270 | [ct.fap.emea@spx.com](mailto:ct.fap.emea@spx.com)  
[spxcooling.com](http://spxcooling.com)

uk\_AV-TS-18 | ISSUED 10/2018

© 2017-2018 SPX COOLING TECHNOLOGIES, INC | ALL RIGHTS RESERVED

In the interest of technological progress, all products are subject to design and/or material change without notice.

