

# MD Everest®

The High-Capacity Modular Preassembled  
Counterflow Cooling Tower

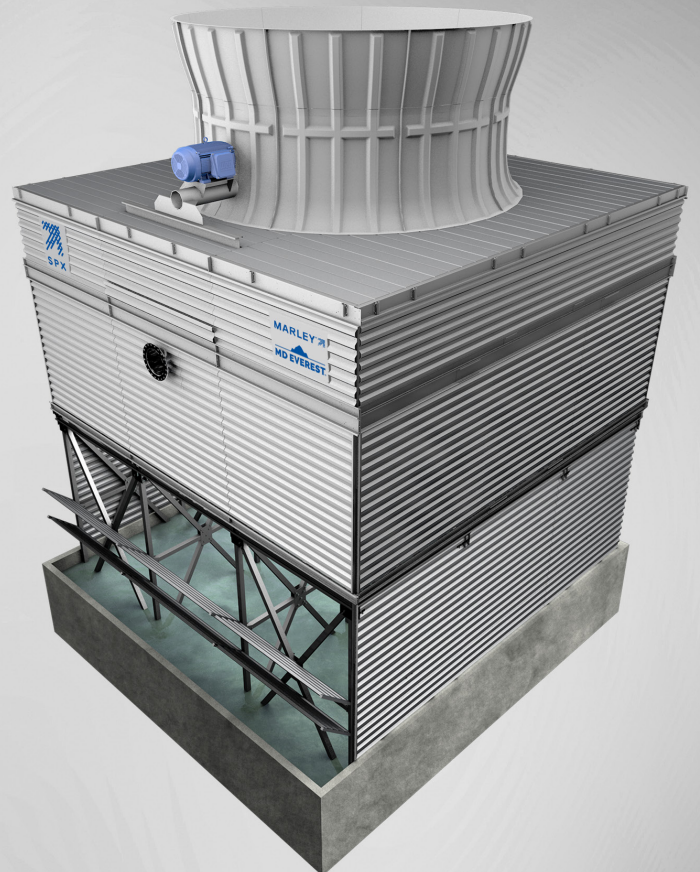
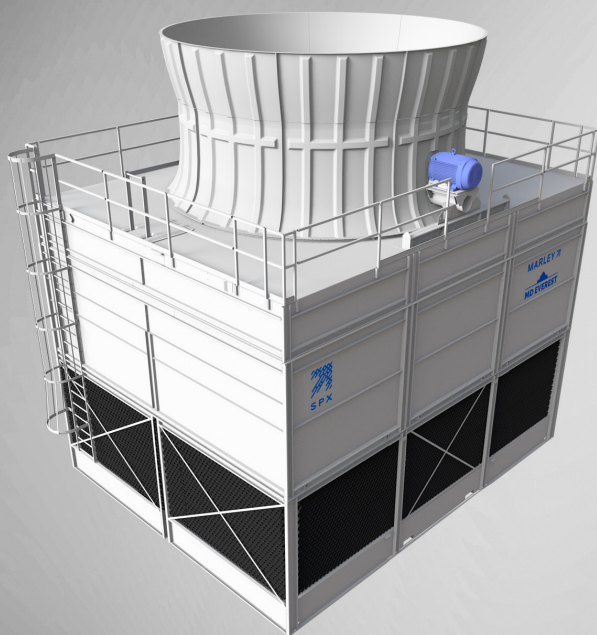

# MD Everest® Cooling Tower MD5027

## Advanced MD Everest Cooling Tower – Factory-Engineered, Preassembled Modules Optimize Installation and Performance

The MD Everest Cooling Tower (MD5027) comprises eight preassembled modules engineered to optimize manufacturing, logistics, on-site installation and lifespan. Uniquely suited for applications with higher cooling demands, including data centers, district energy complexes, health science campuses and industrial complexes, the MD Everest incorporates the robust steel construction of the MD product line, proven to withstand the rigors of harsh environmental exposure. Whether making mechanical equipment selections for a new project or replacing an existing field-constructed cooling tower, the MD Everest Cooling Tower's preassembled, counterflow, modular design offers significant advantages, including faster delivery, easier installation, and operational features that simplify inspections and maintenance.

### INDUSTRIAL-STRENGTH CONSTRUCTION AND MATERIALS

The MD Everest Cooling Tower's robust structure meets seismic and wind load requirements and is designed to meet the rigors of both HVAC and industrial cooling applications using heavy-gauge, corrosion-resistant steel casing and structural members, and Marley heat transfer fill and mechanical components:

- 5-year maintenance-free System 5 Marley Geareducer® gear drive
- Energy-efficient PVC heat exchange fill media
- Motor Outside Airstream (MOA) standard
- 5-year mechanical component warranty

### LOGISTICAL ADVANTAGES

The MD5027 cooling tower's innovative 8-module design speeds manufacture and facilitates shipment and delivery. Mechanical components are shipped installed on modules, simplifying onsite construction. Crane lifts do not exceed 3630 kg.

### CONSISTENTLY HIGH-QUALITY MANUFACTURE

Because MD Everest Cooling Tower modules are crafted and assembled in a controlled factory environment following strict manufacturing standards, the installation quality of the tower is consistently high.

### DECADES OF MARLEY MODULAR DESIGN KNOW-HOW

Twenty years of successfully executing modular tower designs and installations, for both process cooling and HVAC applications, confirms the Marley brand's unparalleled knowledge, experience and reputation for proven, innovative products for efficient evaporative cooling.

### FM APPROVAL OPTION

For applications of two or more cells, the MD Everest Cooling Tower conforms to the FM Approval Standard for cooling towers, Class Number 4930.

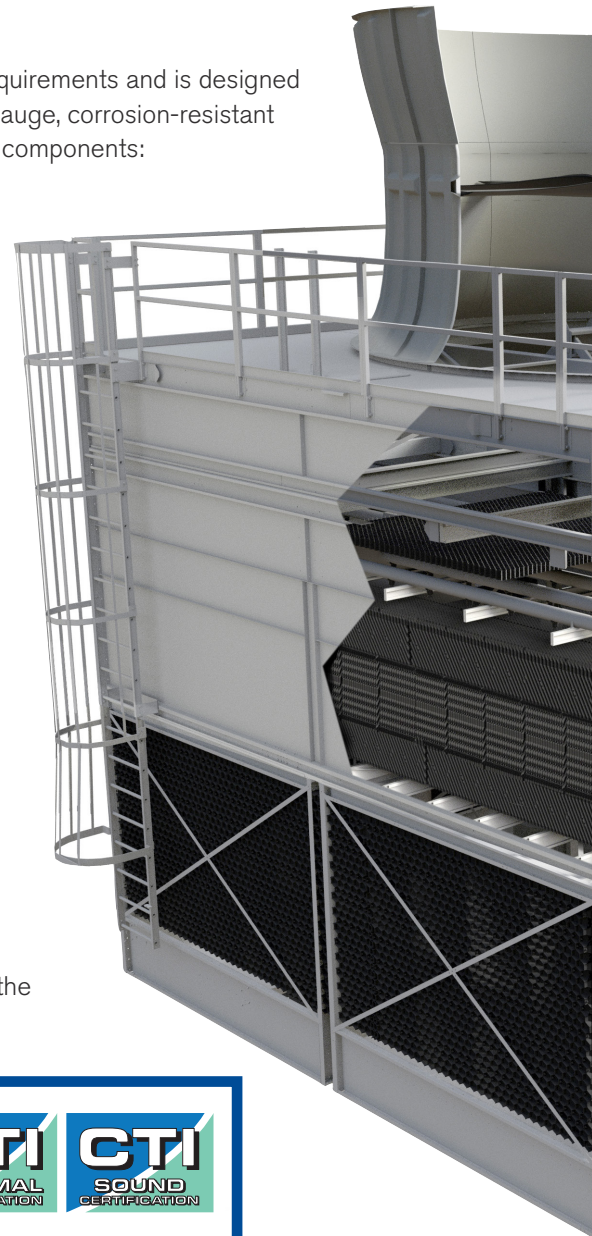

### CERTIFIED THERMAL AND SOUND PERFORMANCE

The MD Everest Cooling Tower is CTI Thermal and Sound certified. This ensures specified heat rejection and noise levels are delivered, eliminating costly site tests



SPX participates in the ECP programme for Cooling Towers. Range – MD Series. Certification Diploma #12.02.006. Ongoing certificate validity: [eurovent-certification.com](http://eurovent-certification.com)



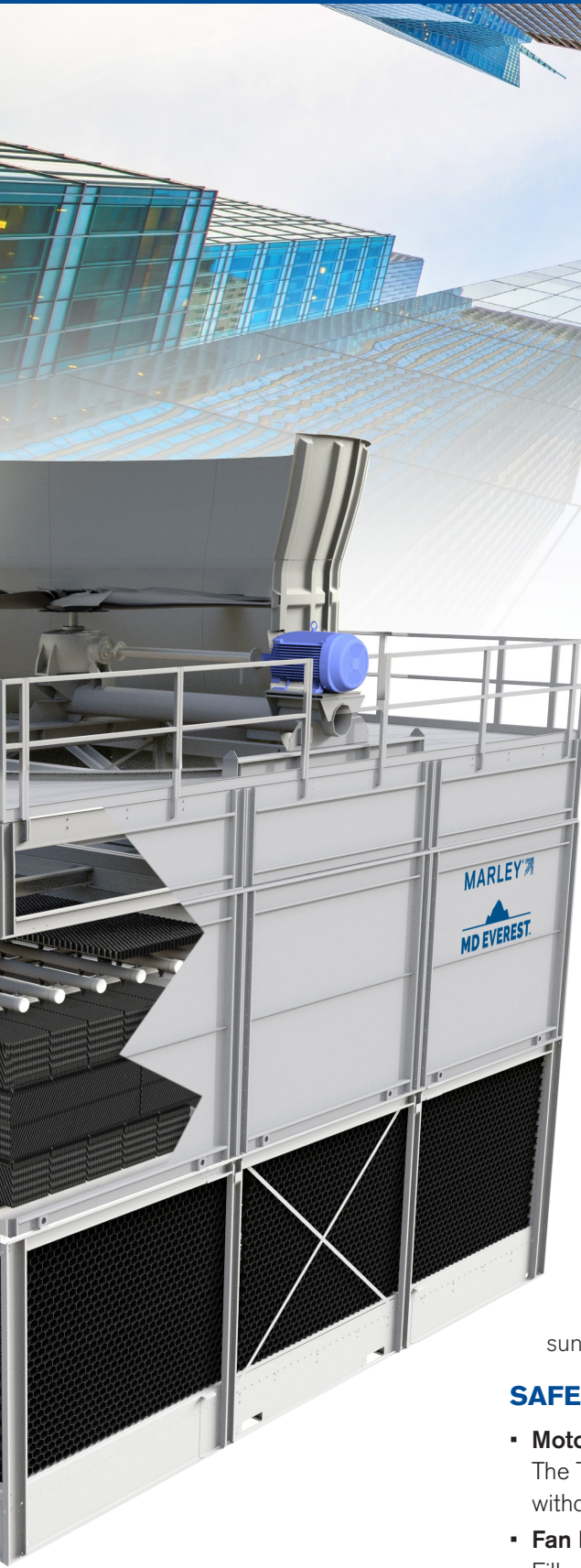

### **DELIVERY 60% SOONER AND INSTALLATION 80% FASTER THAN COMPARABLE FIELD CONSTRUCTED COOLING TOWERS**

Operations are up and running more quickly because the MD Everest's Cooling Tower modules typically deliver to the site 60% sooner and install in about 20% of the time required for field-erected tower components.

### **PATENTED SEALING SYSTEM SIMPLIFIES INSTALLATION**

Patented vertical seals between modules virtually eliminate leak and alignment issues.

### **SAFER ASSEMBLY PROCESS**

The modular design and simplified field assembly process reduce onsite labor and work duration for a safer work environment.

### **LOWEST DRIFT**

The MD Everest Cooling Tower achieves the lowest measureable drift, down to 0.0005 percent of circulating water flow, so less water escapes the tower.

### **PROTECTED HEAT TRANSFER MEDIA**

The wet fill surfaces are totally enclosed, protecting them from exposure to sunlight to discourage algae growth.

### **SAFER MAINTENANCE PROCESSES**

- **Motor Accessible Outside Airstream (MOA)**  
The TEFC motor is located outside the fan cylinder where it is readily accessible without confined-space access.
- **Fan Deck Access Hatch**  
Fill and plenum are accessed from a convenient hatch on the fan deck without need of extra platforms.

# MD Everest® Cooling Tower MD5030–MD5033–MD5036

## MD Everest Models with the Highest Cooling Capacity\*

These MD Everest Cooling Tower models offer up to 58% more cooling capacity per cell compared with other preassembled or modular counterflow cooling towers. With capacities up to 16676 kW, the MD Everest Cooling Tower is an ideal one-to-one match for some of the largest chillers. And with a maximum flow rate of 2862 m<sup>3</sup>/h, it's a strong contender for process cooling applications.

### INDUSTRIAL-STRENGTH CONSTRUCTION AND MATERIALS

The MD Everest Cooling Tower's robust structure meets seismic and wind load requirements and is designed to meet the rigors of HVAC and industrial applications using heavy-duty, corrosion-resistant structural members, and Marley heat transfer fill and mechanical components:

- 5-year maintenance-free System 5 Marley Geareducer® gear drive
- Energy-efficient low-clog PVC heat exchange fill media
- Motor Outside Airstream (MOA) standard
- 5-year mechanical component warranty

### PROTECTED HEAT TRANSFER MEDIA

The wet fill surfaces are totally enclosed, protecting them from exposure to sunlight to discourage algae growth.

### MOTOR ACCESSIBLE OUTSIDE AIRSTREAM

The TEFC motor is located outside the fan cylinder where it is readily accessible for maintenance without confined-space access.

### MODULAR DESIGN ADVANTAGES

The MD Everest Cooling Tower's innovative design speeds manufacture, delivery and installation.

### CONSISTENT QUALITY

Because MD Everest tower modules are built and assembled in a controlled factory environment following strict manufacturing standards, the installation quality of the tower is consistently high.

### ADAPTS TO VARYING WATER QUALITY

These MD Everest Cooling Tower models can employ a range of fill types to accommodate various sources of water.

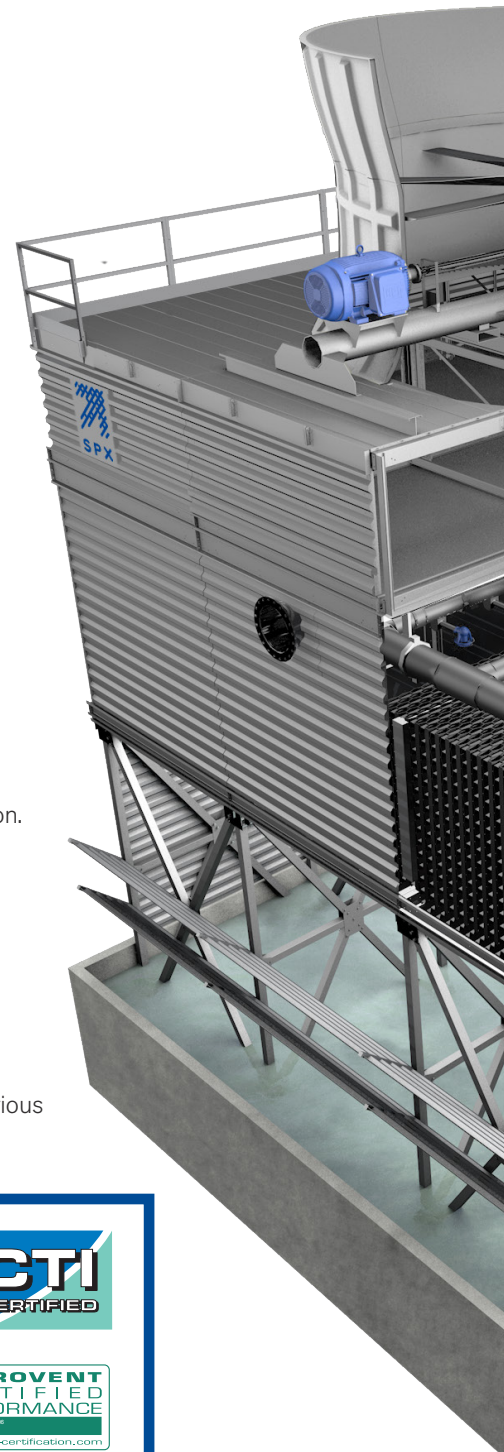

#### CERTIFIED THERMAL PERFORMANCE

The MD Everest Cooling Tower is certified by the Cooling Technology Institute to meet thermal performance as specified, eliminating costly site tests.

SPX participates in the ECP programme for Cooling Towers. Range – MD Series. Certification Diploma #12.02.006. Ongoing certificate validity: [eurovent-certification.com](http://eurovent-certification.com)





### **HIGHEST CAPACITY**

At up to 16676 kW, the MD Everest Cooling Tower is an ideal one-to-one match for large chillers.

### **60% FASTER DELIVERY**

Operations are up and running sooner because the MD Everest tower modules typically deliver to the site 60% faster than field-erected tower components.

### **80% FASTER INSTALLATION**

The MD Everest Cooling Tower arrives onsite in preassembled modules which install in about 20% of the time required for site-constructed towers.

### **INSTALLATION SAVINGS**

The MD Everest Cooling Tower's design minimizes piping and electrical connections to reduce installation costs.

### **LOW DRIFT RATE**

The MD Everest Cooling Tower achieves a low drift rate, down to 0.0005 percent of circulating water flow, so less water escapes the tower.

### **HIGHEST VALUE**

The MD Everest Cooling Tower offers significant advantages compared with other counterflow towers, including unmatched cooling capacity, energy efficiency, fewer components and lower maintenance costs.

# MD Everest® Cooling Tower Specifications

## Model MD5027

### PRODUCT PARAMETERS PER CELL

Model	MD5027
Cooling Capacity*	10,457 kW
Dimensions	L 9.1m   W 7.4m   H 8.8 – 9.7m
Maximum Flow Rate	1,939 m³/hr
Drift Rate	Per industry standard, as low as 0.0005% of circulating water flow

\*Based on 3 gpm/ton at 35° C HW - 29.5° C CW - 25.5°C WB; varies depending on configuration

Modules	8
Fan Diameter	5.5m
Total Height	8.8 – 9.7m
Fan Deck Height	6.6m
Shipping Weight	22,680 kg
Operating Weight	36,287 kg
Maximum Lift Weight	3,629 kg
Module Connections	32 locations

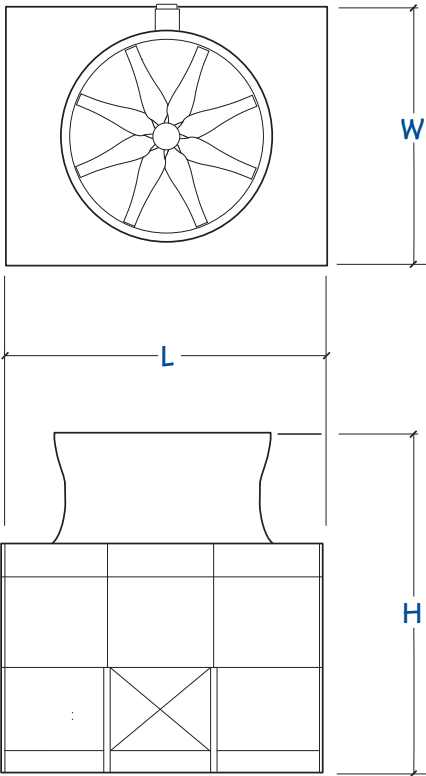

## Models MD5030–MD5033–MD5036

### PRODUCT PARAMETERS PER CELL

Model	Cooling Capacity*	Maximum Flow Rate	Length	Width	Height
MD5030	11663 kW	1976 m <sup>3</sup> /hr	9.3m	9m	varies
MD5033	13289 kW	2378 m <sup>3</sup> /hr	11m	9m	
MD5036	16676 kW	2862 m <sup>3</sup> /hr	11m	11m	

\*Based on 3 gpm/ton at 35° C HW - 29.5° C CW - 25.5° C WB; varies depending on configuration

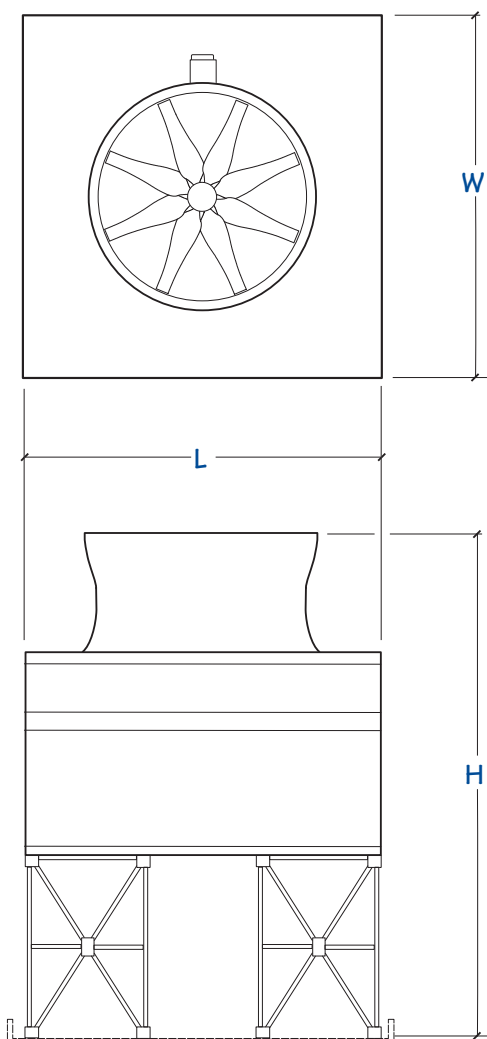

Model	Fan Diameter	Total Height	Operating Weight
MD5030	5.5m	9.3 – 11.1m	34,030 kg
MD5033	5.5m	8.4 – 11.4m	40,835 kg
MD5036	7.3m	8.7 – 12.0m	52,117 kg

Model	Shipping Weight	Maximum Lift Weight
MD5030	22,686 kg	3,857 kg
MD5033	27,223 kg	4,990 kg
MD5036	38,566 kg	5,444 kg

## UNMATCHED VALUE

The MD Everest Cooling Tower offers significant advantages compared with other factory-assembled counterflow towers, including expanded cooling capacity, energy efficiency, fewer components, and lower maintenance costs.

### ADDITIONAL MARLEY COOLING TOWER PUBLICATIONS

Access these publications and more information at [spxcooling.com](http://spxcooling.com)



Marley NC Everest  
Cooling Tower Brochure



Marley MD  
Cooling Tower Brochure



Marley Products and  
Services Brochure



Factory-Assembled  
Cooling Towers for Power  
and Industrial Applications

### SPX COOLING TECHNOLOGIES, INC.

3 KNIGHTSBRIDGE PARK, WAINWRIGHT ROAD  
WORCESTER WR4 9FA UK

44 1905 750 270 | [ct.fap.emea@spx.com](mailto:ct.fap.emea@spx.com)

[spxcooling.com](http://spxcooling.com)

uk\_MDE-26 | ISSUED 03/2026

©2018-2026 SPX COOLING TECHNOLOGIES, INC.

ALL RIGHTS RESERVED.

In the interest of technological progress, all products are subject  
to design and/or material change without notice.