



## THE NC-QUIET BY DESIGN

The NC is the result of extensive design studies focused on cooling tower sound control. These studies were complicated by the fact that the cooling tower market is typically driven by one of two powerful, yet often conflicting requirements. The most common is for a cooling tower that provides the required heat rejection capacity with a high level of reliability at low cost. Sound control, while important, is not the primary consideration for this application.

The other requirement, which is becoming ever more important in our crowded, fast-paced society, is driven by conditions that demand the lowest practical sound level. Energy efficiency, reliability, ease of maintenance and reasonable cost, while still extremely important, are not the highest priorities

In the first case, sound is important, while in the second case it is extremely important. To best satisfy these two competing market requirements we created a multi-tiered approach, through key mechanical equipment selections, to sound control. The result is more options than any other cooling tower on the market today.

The result is a line of towers capable of meeting all but the most restrictive noise limitations—and that will react favorably to natural attenuation. Where the tower has been sized to operate within an enclosure, the enclosure itself will have a damping effect on sound. Sound also declines with distance—by about 6 dBA each time the distance doubles.

All standard NC cooling towers are equipped with low sound fans. This in combination with zero-splash crossflow film-fill results in a line of towers capable of meeting most noise limitations. Where noise at a critical point is likely to exceed an acceptable limit, several other options are available—listed below in ascending order of cost impact:

- The Marley “Quiet Package” includes the affordable Quiet Fan mechanical option, optimized to achieve the lowest possible sound levels while maintaining efficiency.
- A Marley Variable Speed Drive automatically minimizes the tower’s noise level during periods of reduced load and/or reduced ambient temperature without sacrificing the system’s ability to maintain a constant cold water temperature. This is a relatively inexpensive solution, and can pay for itself quickly in reduced energy costs. The natural nighttime reduction in wet-bulb temperature makes this a very feasible solution in most areas of the world. It also eliminates fan cycling. In combination with a Marley Quiet Package, the Marley Variable Speed Drive is capable of meeting all but the most restrictive noise limitations.
- The most extreme cases may require inlet and discharge sound attenuator sections—however, the static pressure loss imposed by discharge attenuators may necessitate an increase in tower size. Two stages of inlet or discharge attenuators supported by the tower and designed and tested for the most stringent requirements are available as an option. See page 24.
- For more severe cases requiring the lowest possible fan sound levels the Marley “Ultra Quiet” fan option is now available on most NC models. Tower height will increase—obtain current sales drawings from your Marley sales representative for accurate dimensions.

The advantage is yours. You now have the choices you need to balance your project’s performance, space and cost requirements with your sound level needs for a win-win solution to your cooling system design.

## ENCLOSURES

Occasionally, cooling towers are located inside architectural enclosures for aesthetic reasons. Although NC towers adapt well to enclosures, the designer must realize the potential impact of a poorly arranged enclosure on the tower’s performance and operation. The designer must take care to provide generous air inlet paths, and the tower’s fan cylinder discharge height should not be lower than the elevation of the top of the enclosure. Marley white paper [Thermal Science H-004 “External Influences on Cooling Tower Performance”](#) is available at [spxcooling.com](http://spxcooling.com) or from your Marley sales representative.

As suggested in the aforementioned Technical Report, it may also be advisable to specify a design wet-bulb temperature  $\frac{1}{2}^{\circ}\text{C}$  higher than normal to compensate for potential recirculation initiated by the enclosure. You’ll benefit from discussing your project with your Marley sales representative.



Marley “Ultra Quiet” fan

**SYSTEM CLEANLINESS**

Cooling towers are very effective air washers. Atmospheric dust able to pass through the relatively small louver openings will enter the circulating water system. Increased concentrations can intensify system maintenance by clogging screens and strainers—and smaller particulates can coat system heat transfer surfaces. In areas of low flow velocity—such as the cold water basin—sedimentary deposits can provide a breeding ground for bacteria.

In areas prone to dust and sedimentation, you should consider installing some means for keeping the cold water basin clean. Typical devices include side stream filters and a variety of filtration media.

**WATER TREATMENT**

To control the buildup of dissolved solids resulting from water evaporation, as well as airborne impurities and biological contaminants including Legionella, an effective consistent water treatment program is required. Simple blowdown may be adequate to control corrosion and scale, but biological contamination can only be controlled with biocides.

An acceptable water treatment program must be compatible with the variety of materials incorporated in a cooling tower—ideally the pH of the circulating water should fall between 6.5 and 8.0. Batch feeding of chemicals directly into the cooling tower is not a good practice since localized damage to the tower is possible. Specific startup instructions and additional water quality recommendations can be found in the **NC User Manual** which accompanies the tower and also is available from your local Marley sales representative. For complete water treatment recommendations, consult a competent, qualified water treatment supplier.

**⚠ CAUTION**

The cooling tower must be located at such distance and direction to avoid the possibility of contaminated discharge air being drawn into building fresh air intake ducts. The purchaser should obtain the services of a Licensed Professional Engineer or Registered Architect to certify that the location of the cooling tower is in compliance with applicable air pollution, fire and clean air codes.

**TYPICAL APPLICATIONS**

The NC tower is an excellent choice for normal applications requiring cold water for the dissipation of heat. This includes condenser water cooling for air conditioning, refrigeration, and thermal storage systems, as well as their utilization for free-cooling in all of those systems. The NC can also be used in the cooling of jacket water for engines and air compressors, and are widely applied to dissipate waste heat in a variety of industrial, power and manufacturing processes.

Choosing the all stainless steel construction option, the NC can be confidently applied in unusually corrosive processes and operating environments. However, no single product line can answer all problems, and selective judgement should be exercised in the following situations



*SPX participates in the ECP programme for Cooling Towers. Range – NC Series. Certification Diploma #12.02.007. Ongoing certificate validity: eurovent-certification.com*

**APPLICATIONS REQUIRING ALTERNATIVE COOLING TOWER SELECTIONS**

Certain types of applications are incompatible with any cooling tower with film fill—whether NC or a competitive tower of similar manufacture. Film fill is subject to distortion in high water temperatures, and the narrow passages are easily clogged by turbid or debris-laden water. Some of the applications, which call for alternative tower designs are:

- **Ethylene glycol content**—can plug fill passages as slime and algae accumulate to feed on the available organic materials.
- **Fatty acid content**—found in processes such as soap and detergent manufacturing and some food processing—fatty acids pose a serious threat for plugging fill passages.
- **Particulate carry over**—often found in steel mills and cement plants—can both cause fill plugging, and can build up to potentially damaging levels on tower structure.
- **Pulp carry over**—typical of the paper industry and food processing where vacuum pumps or barometric condensers are used. Causes fill plugging which may be intensified by algae.

**ALTERNATIVE SELECTIONS**

In addition to the NC, SPX Cooling offers a full scope of products in various designs and capacities to meet the special demands of specific applications.

spxcooling.com—visit us on the web for a complete list of products, services, publications and to find your nearest sales representative.

NC8401 NC8402 NC8403 NC8405

Use this data for preliminary layouts only. Obtain current drawing from your local Marley sales representative.

**CoolSpec™** web-based selection software, available at [coolspec.com](http://coolspec.com) provides NC model recommendations based on customer's specific design requirements.

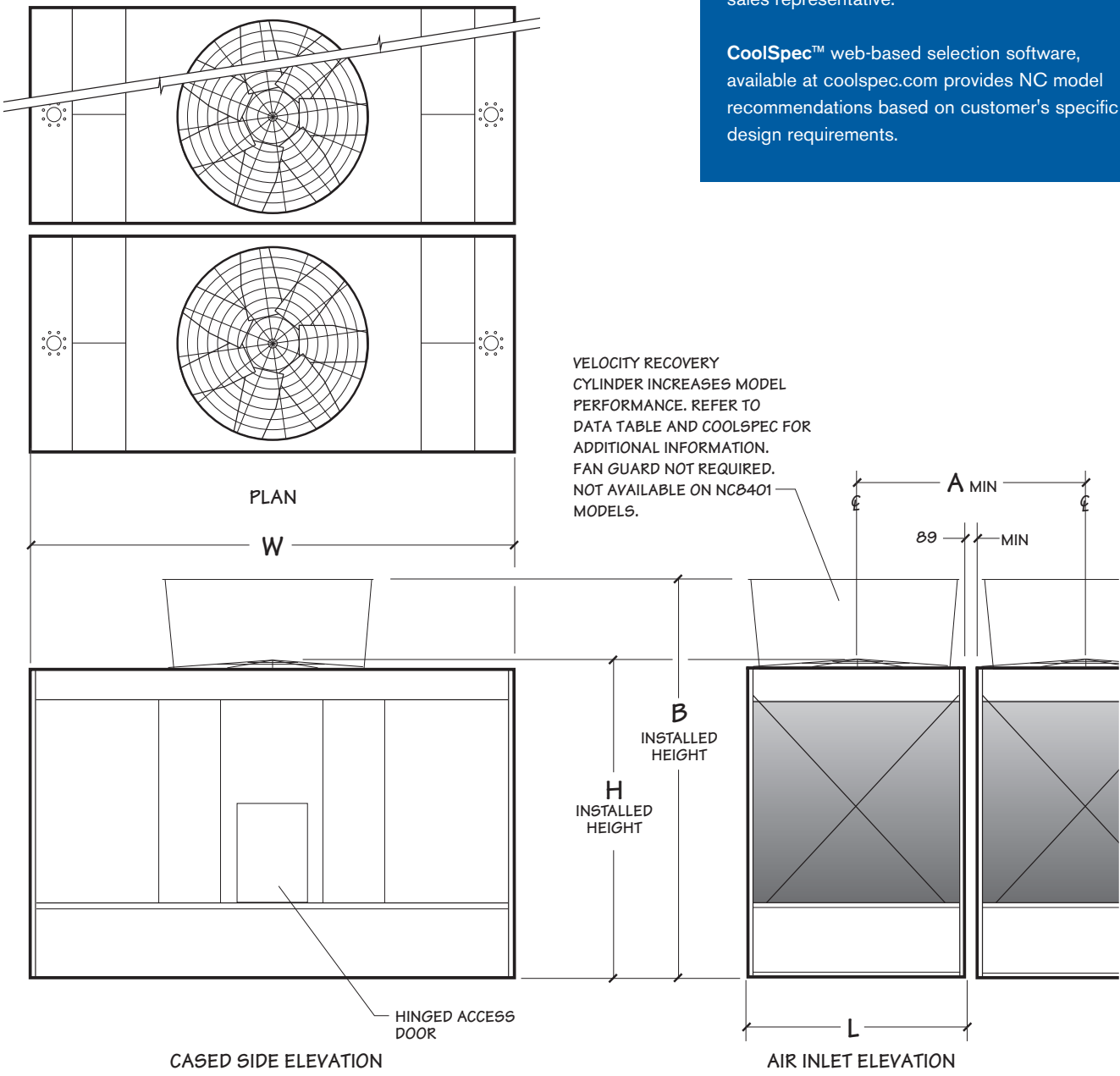

NC8401 NC8402 NC8403 NC8405

Model note 2	Nominal Capacity kW note 3	Nominal Capacity with VR Cylinder note 3	Motor kW	Design Operating Weight kg	Shipping Weight kg	Dimensions				
						L	W	H	B	A
NC8401G-1	444	–	1.5	3542	1807	1988	3912	3105	–	2077
NC8401H-1	514	–	2.2							
NC8401K-1	611	–	3.7							
NC8401M-1	699	–	5.5							
NC8401N-1	769	–	7.5							
NC8401P-1	870	–	11							
NC8402H-1	686	739	2.2	4613	2151	2559	4318	3124	4495	2648
NC8402K-1	818	875	3.7							
NC8402M-1	932	1002	5.5							
NC8402N-1	1038	1108	7.5							
NC8402P-1	1165	1244	11							
NC8402Q-1	1266	1354	15							
NC8403H-1	862	941	2.2	7172	3362	2559	5537	3638	5010	2648
NC8403K-1	1042	1126	3.7							
NC8403M-1	1183	1279	5.5							
NC8403N-1	1306	1407	7.5							
NC8403P-1	1447	1596	11							
NC8403Q-1	1627	1750	15							
NC8403R-1	1719	1855	18.5							
NC8403S-1	1847	1952	22							
NC8403T-1	1970	2119	30							
NC8405H-1	1064	1082	2.2							
NC8405K-1	1231	1284	3.7							
NC8405M-1	1398	1460	5.5							
NC8405N-1	1556	1622	7.5							
NC8405P-1	1772	1847	11							
NC8405Q-1	1943	2027	15							
NC8405R-1	2062	2159	18.5							
NC8405S-1	2159	2255	22							
NC8405T-1	2370	2440	30							
NC8405U-1	2489	2598	37							

NOTE

- 1 Use this bulletin for preliminary layouts only. Obtain current drawings from your Marley sales representative. All table data is per cell.
- 2 Last numeral of model number indicates number of cells. Change as appropriate for your selection.
- 3 Nominal cooling capacity based upon 35°C HW, 29.5°C CW, 25.5°C WB, 0.155 m<sup>3</sup>/hr per kW and standard low sound fans. CoolSpec web-based selection software provides NC model recommendations based on specific design requirements.
- 4 Standard overflow is a 4" dia. standpipe in the collection basin floor. The standpipe removes for flush-out and draining. See page 20 for side overflow option.
- 5 Outlet sizes vary according to flow and arrangement. See pages 20 and 21 for outlet sizes and details.
- 6 Makeup water connection may be 1" or 2" dia., depending upon tower heat load, water pressure, and desired connections. See page 15 for additional information.

NC8407 NC8409

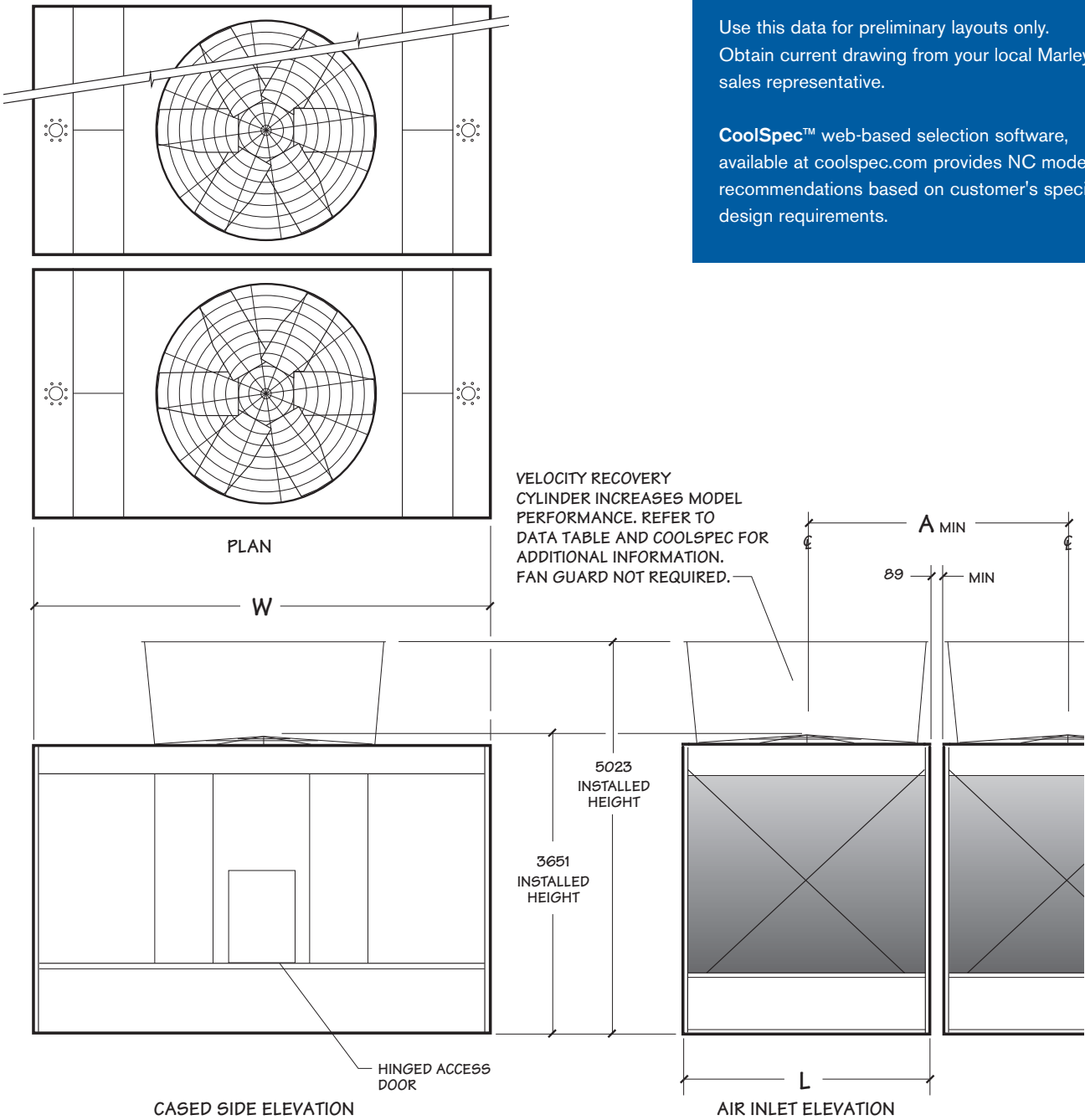

Use this data for preliminary layouts only. Obtain current drawing from your local Marley sales representative.

**CoolSpec™** web-based selection software, available at [coolspec.com](http://coolspec.com) provides NC model recommendations based on customer's specific design requirements.

NC8407 NC8409

Model note 2	Nominal Capacity kW note 3	Nominal Capacity w/ VR Cylinder kW note 3	Motor kW	Design Operating Weight kg	Shipping Weight kg	Dimensions		
						L	W	A
NC8407K-1	1407	1451	3.7	11260	5060	3626	6401	3715
NC8407M-1	1605	1671	5.5					
NC8407N-1	1763	1838	7.5					
NC8407P-1	2014	2093	11					
NC8407Q-1	2181	2273	15					
NC8407R-1	2344	2440	18.5					
NC8407S-1	2471	2572	22					
NC8407T-1	2695	2805	30					
NC8407U-1	2893	3003	37					
NC8407V-1	3034	3126	45					
NC8409M-1	1833	1877	5.5	13666	5977	4235	6833	4324
NC8409N-1	2018	2075	7.5					
NC8409P-1	2304	2365	11					
NC8409Q-1	2528	2598	15					
NC8409R-1	2713	2787	18.5					
NC8409S-1	2858	2924	22					
NC8409T-1	3100	3179	30					
NC8409U-1	3311	3390	37					
NC8409V-1	3465	3544	45					
NC8409W-1	3645	3728	55					

NOTE

- 1 Use this bulletin for preliminary layouts only. Obtain current drawings from your Marley sales representative. All table data is per cell.
- 2 Last numeral of model number indicates number of cells. Change as appropriate for your selection.
- 3 Nominal cooling capacity based upon 35°C HW, 29.5°C CW, 25.5°C WB, 0.155 m<sup>3</sup>/hr per kW and standard low sound fans. CoolSpec web-based selection software provides NC model recommendations based on specific design requirements.
- 4 Standard overflow is a 4" dia. standpipe in the collection basin floor. The standpipe removes for flush-out and draining. See page 20 for side overflow option.
- 5 Outlet sizes vary according to flow and arrangement. See pages 20 and 21 for outlet sizes and details.
- 6 Makeup water connection may be 1" or 2" dia., depending upon tower heat load, water pressure, and desired connections. See page 15 for additional information.

NC8410 NC8411 NC8412

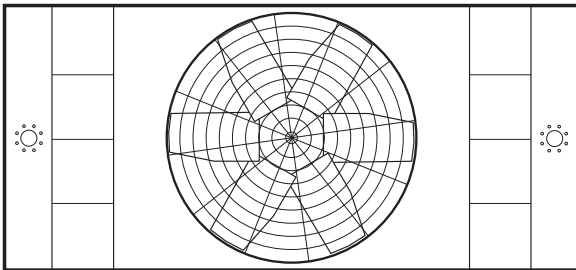
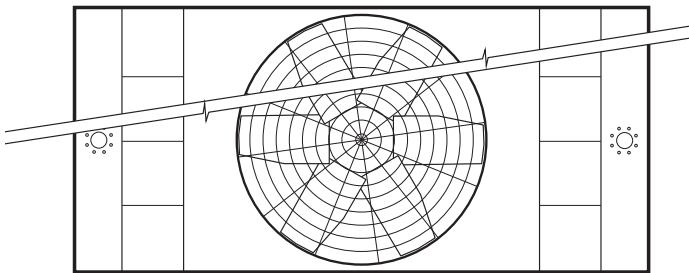

PLAN

6833

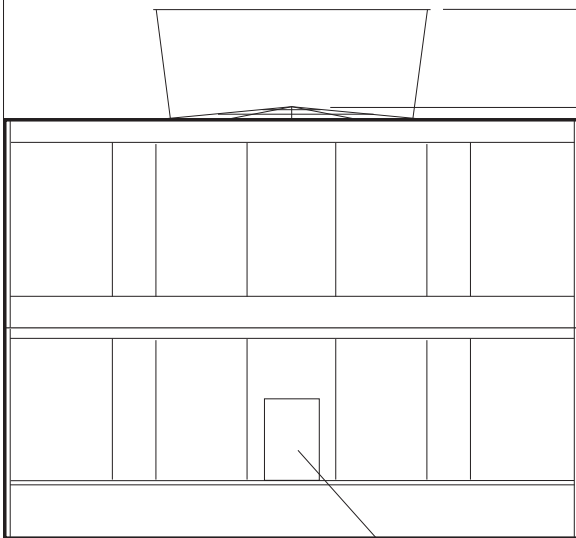

CASED SIDE ELEVATION

HINGED ACCESS DOOR

VELOCITY RECOVERY CYLINDER INCREASES MODEL PERFORMANCE. REFER TO DATA TABLE AND COOLSPEC FOR ADDITIONAL INFORMATION. FAN GUARD NOT REQUIRED.

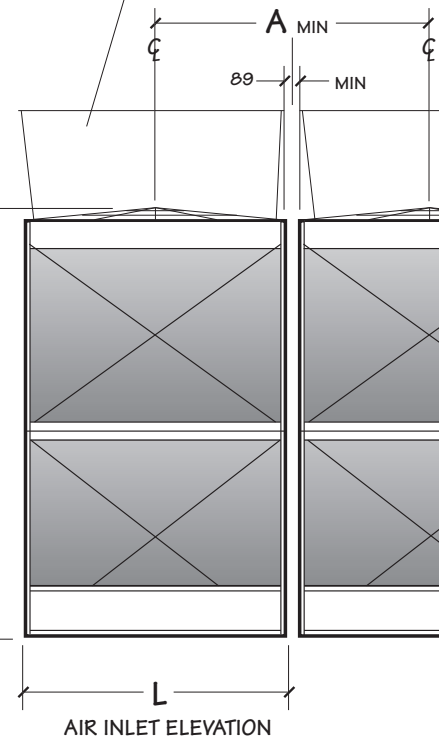

Use this data for preliminary layouts only. Obtain current drawing from your local Marley sales representative.

CoolSpec™ web-based selection software, available at [coolspec.com](http://coolspec.com) provides NC model recommendations based on customer's specific design requirements.



NC8410 NC8411 NC8412

Model note 2	Nominal Capacity kW note 3	Nominal Capacity w/ VR Cylinder kW note 3	Motor kW	Design Operating Weight kg	Shipping Weight kg	Dimensions			
						L	H	B	A
NC8410N-1	2190	2295	7.5	15238	7399	3626	4877	6248	3715
NC8410P-1	2489	2607	11						
NC8410Q-1	2726	2875	15						
NC8410R-1	2924	3073	18.5						
NC8410S-1	3091	3249	22						
NC8410T-1	3355	3526	30						
NC8410U-1	3575	3764	37						
NC8410V-1	3750	3957	45						
NC8410W-1	3939	4106	55						
NC8411N-1	2401	2528	7.5	16935	7987	3626	5742	7114	3715
NC8411P-1	2704	2862	11						
NC8411Q-1	2955	3122	15						
NC8411R-1	3152	3346	18.5						
NC8411S-1	3333	3513	22						
NC8411T-1	3636	3821	30						
NC8411U-1	3878	4080	37						
NC8411V-1	4089	4322	45						
NC8411W-1	4326	4581	55						
NC8412P-1	3078	3240	11	19466	8962	4235	5742	7114	4324
NC8412Q-1	3355	3513	15						
NC8412R-1	3579	3755	18.5						
NC8412S-1	3777	3961	22						
NC8412T-1	4115	4317	30						
NC8412U-1	4401	4594	37						
NC8412V-1	4630	4841	45						
NC8412W-1	4946	5166	55						
NC8412X-1	5276	5522	75						

NOTE

- 1 Use this bulletin for preliminary layouts only. Obtain current drawings from your Marley sales representative. All table data is per cell.
- 2 Last numeral of model number indicates number of cells. Change as appropriate for your selection.
- 3 Nominal cooling capacity based upon 35°C HW, 29.5°C CW, 25.5°C WB, 0.155 m<sup>3</sup>/hr per kW and standard low sound fans. CoolSpec web-based selection software provides NC model recommendations based on specific design requirements.
- 4 Standard overflow is a 4" dia. standpipe in the collection basin floor. The standpipe removes for flush-out and draining. See page 20 for side overflow option.
- 5 Outlet sizes vary according to flow and arrangement. See pages 20 and 21 for outlet sizes and details.
- 6 Makeup water connection may be 1" or 2" dia., depending upon tower heat load, water pressure, and desired connections. See page 15 for additional information.

NC8413 NC8414

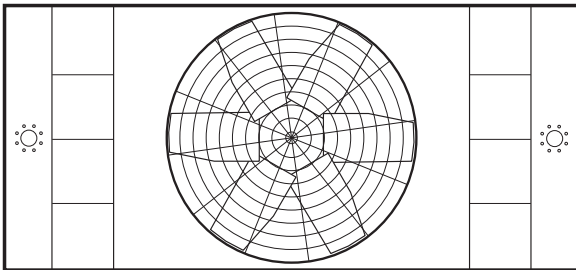
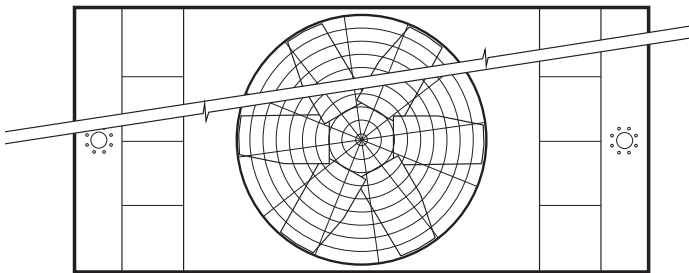

PLAN

6833

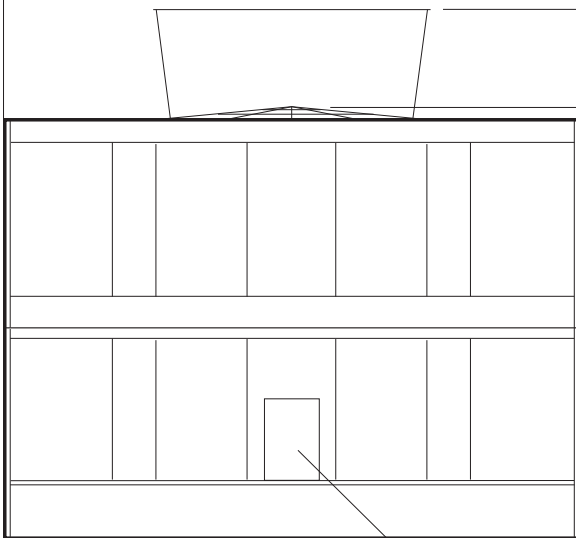

CASED SIDE ELEVATION

HINGED ACCESS DOOR

8260  
INSTALLED  
HEIGHT

6888  
INSTALLED  
HEIGHT

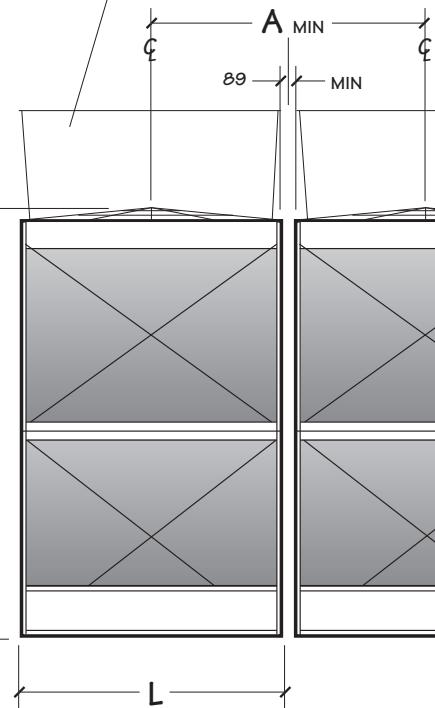

AIR INLET ELEVATION

VELOCITY RECOVERY CYLINDER  
INCREASES MODEL PERFORMANCE.  
REFER TO DATA TABLE AND COOLSPEC  
FOR ADDITIONAL INFORMATION.  
FAN GUARD NOT REQUIRED.

Use this data for preliminary layouts only. Obtain current drawing from your local Marley sales representative.

**CoolSpec™** web-based selection software, available at [coolspec.com](http://coolspec.com) provides NC model recommendations based on customer's specific design requirements.

NC8413 NC8414

Model note 2	Nominal Capacity kW note 3	Nominal Capacity w/ VR Cylinder kW note 3	Motor kW	Design Operating Weight kg	Shipping Weight kg	Dimensions	
						L	A
NC8413N-1	2656	2845	7.5	19030	8884	3626	3715
NC8413P-1	2990	3232	11				
NC8413Q-1	3249	3465	15				
NC8413R-1	3478	3715	18.5				
NC8413S-1	3667	3913	22				
NC8413T-1	3979	4265	30				
NC8413U-1	4225	4498	37				
NC8413V-1	4449	4731	45				
NC8413W-1	4717	5012	55				
NC8413X-1	5052	5359	75				
NC8414P-1	3346	3544	11	21933	10023	4235	4324
NC8414Q-1	3636	3851	15				
NC8414R-1	3882	4102	18.5				
NC8414S-1	4084	4322	22				
NC8414T-1	4445	4739	30				
NC8414U-1	4841	5104	37				
NC8414V-1	5074	5342	45				
NC8414W-1	5333	5720	55				
NC8414X-1	5693	6001	75				
NC8414Y-1	6155	6537	90				

NOTE

- 1 Use this bulletin for preliminary layouts only. Obtain current drawings from your Marley sales representative. All table data is per cell.
- 2 Last numeral of model number indicates number of cells. Change as appropriate for your selection.
- 3 Nominal cooling capacity based upon 35°C HW, 29.5°C CW, 25.5°C WB, 0.155 m<sup>3</sup>/hr per kW and standard low sound fans. CoolSpec web-based selection software provides NC model recommendations based on specific design requirements.
- 4 Standard overflow is a 4" dia. standpipe in the collection basin floor. The standpipe removes for flush-out and draining. See page 20 for side overflow option.
- 5 Outlet sizes vary according to flow and arrangement. See pages 20 and 21 for outlet sizes and details.
- 6 Makeup water connection may be 1" or 2" dia., depending upon tower heat load, water pressure, and desired connections. See page 15 for additional information.

NC8422

Use this data for preliminary layouts only. Obtain current drawing from your local Marley sales representative.

**CoolSpec™** web-based selection software, available at [coolspec.com](http://coolspec.com) provides NC model recommendations based on customer's specific design requirements.

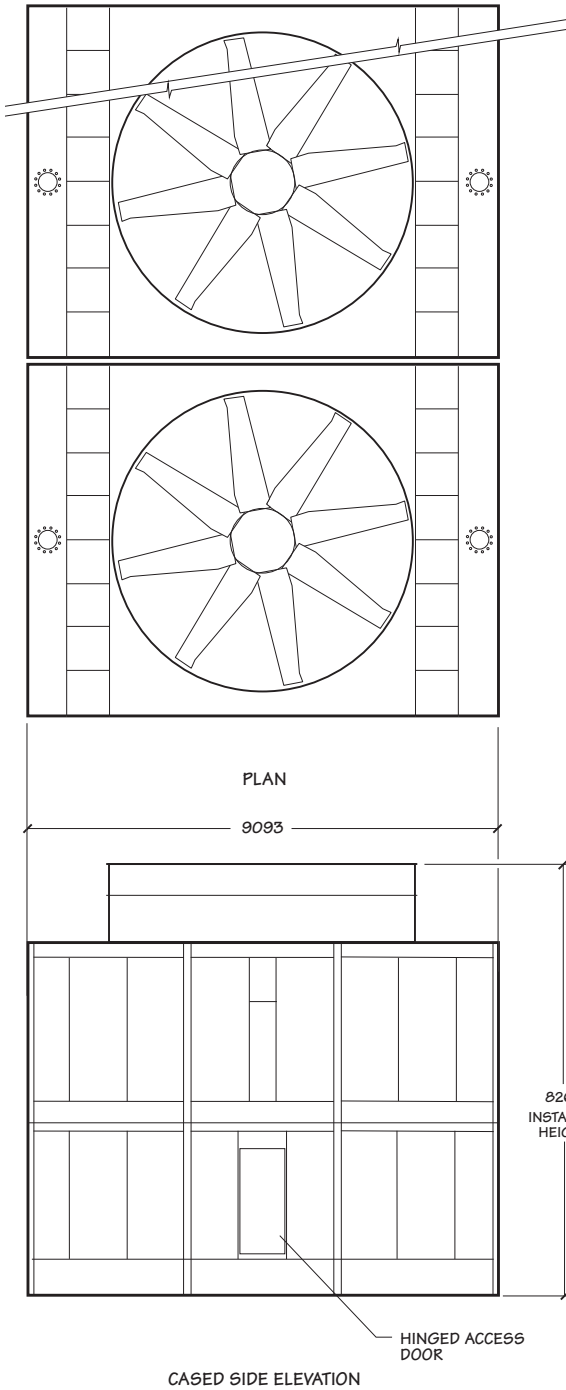

Model note 2	Nominal Capacity kW note 3	Motor kW	Design Operating Weight kg	Shipping Weight kg
NC8422R-1	5763	18.5	45 805	18 806
NC8422S-1	6080	22		
NC8422T-1	6550	30		
NC8422U-1	7012	37		
NC8422V-1	7421	45		
NC8422W-1	7957	55		
NC8422X-1	8647	75		
NC8422Y-1	9144	90		
NC8422Z-1	9623	110		

NOTE

- 1 Use this bulletin for preliminary layouts only. Obtain current drawings from your Marley sales representative. All table data is per cell.
- 2 Last numeral of model number indicates number of cells. Change as appropriate for your selection.
- 3 Nominal cooling capacity based upon 35°C HW, 29.5°C CW, 25.5°C WB, 0.155 m<sup>3</sup>/hr per kW and standard low sound fans. CoolSpec web-based selection software provides NC model recommendations based on specific design requirements.
- 4 Standard overflow is a 4" dia. standpipe in the collection basin floor. The standpipe removes for flush-out and draining.
- 5 Outlet sizes vary according to gpm and arrangement. See pages 23 for outlet sizes and details.
- 6 Makeup water connection may be 1" or 2" dia., depending upon tower heat load, water pressure, and desired connections. See page 15 for additional information.

When the ambient air temperature falls below 0°C, the water in a cooling tower can freeze. Marley white paper *Thermal Science H-003 “Cooling Towers and Freezing Weather”* describes how to prevent freezing during operation. Available at [spxcooling.com](http://spxcooling.com) or from your Marley sales representative.

During shutdown, water collects in the cold water basin and may freeze solid. You can prevent freezing by adding heat to the water left in the tower—or, you can drain the tower and all exposed pipework at shutdown.

### ELECTRIC BASIN HEATERS

An automatic basin water heater system is available consisting of the following components:

- Standard weatherproof (IP55) enclosure, rating depending on model and minimum expected winter temperature.
- Ratings are in kW for specified ambient temperature. For lower ambient temperatures refer to SPX engineering for advice.
- Standard electrical supply is 380/415 V 3ph (220/240V 1 ph available as extra cost option).
- Heater has an integral thermostat, set point nominally 3°C but adjustable to suit operating requirements.

Heater components are normally shipped separately for installation by others.

**Note:** any exposed piping that is still filled with water at shutdown—including the makeup water line—should be electrically traced and insulated (by others).

### INDOOR STORAGE TANK

With this type of system, water flows from an indoor tank, through the load system, and back to the tower, where it is cooled. The cooled water flows by gravity from the tower to the tank located in a heated space. At shutdown, all exposed water drains into the tank, where it is safe from freezing.

The amount of water needed to successfully operate the system depends on the tower size and flow and on the volume of water contained in the piping system to and from the tower. You must select a tank large enough to contain those combined volumes—plus a level sufficient to maintain a flooded suction on your pump. Control makeup water according to the level where the tank stabilizes during operation.

Tired of having to design your piping and tower layout to accommodate the standards of cooling tower manufacturers? Marley's multiple variety of piping systems accommodates your design intentions to make your layout of the NC both expedient and economical.

- Single or dual hot water inlet connections.
- Side inlet, bottom inlet or top inlet connections.
- Side cold water outlet connections. NC8401-NC8414.
- Bottom cold water outlet connections.
- A variety of makeup, overflow and drain options.

For the single inlet connection all piping to the distribution basins is part of the tower package. Installation and design costs are reduced and the need for extra piping and supports are eliminated. The single bottom inlet connection is perfect for multicell applications—keeping all the inlet piping below the tower.

Unless otherwise specified, single-cell towers – NC8401 through NC8414 – normally have a cased-face outlet appropriate for the design water flow rate—see pages 20 and 21. This usually assures the lowest possible installed tower elevation. Cased-face outlet connection pipes extend approximately 3" outside the basin, and are beveled for weld connection and also grooved for a mechanical coupling.

Outlet piping can be kept below the cold water basin level by choosing either a depressed sump or a bottom outlet connection in lieu of the cased-face outlets. Both outlet designs conform to standard class 125 ANSI pipe flange specifications. Easily removable debris screens are optional on bottom outlets and are standard on all other outlet arrangements.

Depressed sumps are made of inert fire-retardant FRP or heavy-gauge welded stainless steel. Unless otherwise specified towers with galvanized steel collection basins are supplied with FRP sumps and towers with stainless steel basins are supplied with stainless sumps.

Multicell towers, intended to operate together as a common unit, are joined by steel flumes between the collection basins or piping below the tower basins. These connectors equalize the operating water level between basins and also provide a flow passage from cells not equipped with outlets or makeup valves, often eliminating the need to specify an outlet and makeup valve for each cell on a multicell installation.

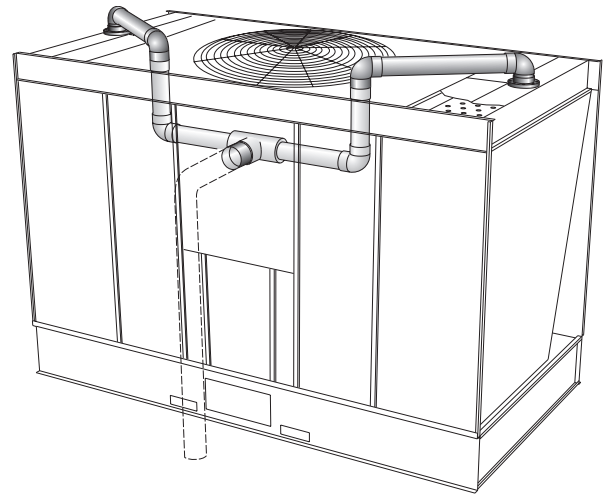

**SIDE INLET PIPING**

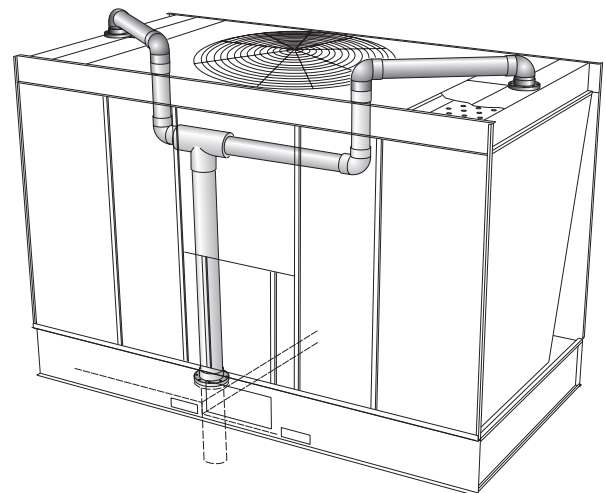

**BOTTOM INLET PIPING**

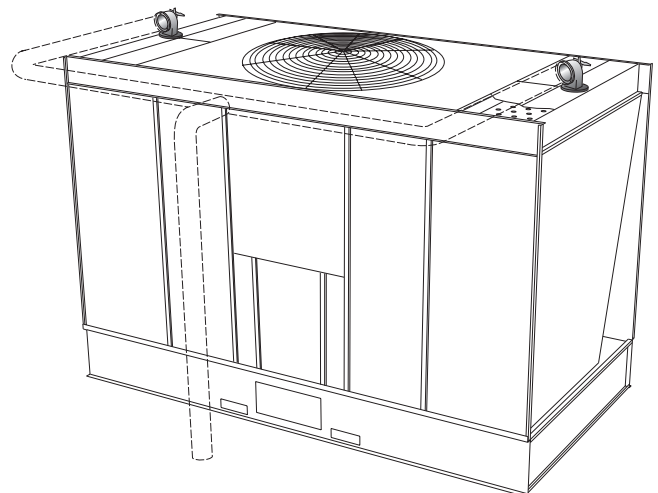

**DUAL TOP INLET PIPING**

If each cell is to be equipped with an outlet, cased-face outlet – NC8401 through NC8414 – can be used on end cells of multicell towers, but not on interior cells. For direct outlet from each cell on installations of three or more cells, use either the depressed sump or bottom outlet on interior cells.

The best choice for a tower used with a remote or indoor storage tank—see page 13—or on a concrete cold water basin is usually a bottom outlet.

A cased-face outlet equipped tower – NC8401 through NC8414 – can be installed on a flat concrete slab if a side drain and overflow are also specified—see page 20. Consult your Marley sales representative for complete information.

**MAKEUP**

The amount of water constantly evaporated from a cooling tower varies directly with the heat load applied. In addition to evaporation, water is normally lost to the blowdown (bleed-off) necessary to maintain dissolved solids concentration at an acceptable level in the circulating water system.

The NC is equipped with one or more float-operated, mechanical makeup valves to automatically replenish this lost water. The tables on this page, calculated for a concentration of 3 times normal, indicate the rate of water loss—and the size of valve(s) required. If your installation’s cold water basin will drain by gravity to a remote storage tank—or if you plan a separate means of controlling makeup water—a price reduction is available for deleting the Marley valve(s). We also offer an optional electronic liquid-level control.

In most instances cooling towers will see the highest water usage at design heat load. Off design conditions (99% of the time) water usage will be less. For a better understanding of how much water your application will use throughout the year, consult our water usage calculator at:

[spxcooling.com/water-calculator](http://spxcooling.com/water-calculator)

If too much water is still being consumed consult your Marley sales representative for water saving alternatives.

Makeup Water Flow Required – m <sup>3</sup> /hr to Maintain Three (3) Concentrations						
Tower m <sup>3</sup> /hr	Cooling “Range” (hot water minus cold water)					
	3°C	6°C	8°C	12°C	17°C	24°C
45	.5	.7	.9	1	2	2
91	.7	1	2	2	3	5
136	.9	2	3	3	5	7
182	1	2	3	5	7	9
227	2	3	4	6	9	11
341	2	4	7	9	13	17
454	3	6	9	11	17	23
681	4	9	13	17	26	34
908	6	11	17	23	34	45
1135	7	14	21	28	43	57
1362	9	17	26	34	51	68
1816	11	23	34	45	68	91

**NOTE**

- If circulating water is to be maintained at 2 concentrations instead of 3, multiply table m<sup>3</sup>/hr values by 1.36 before sizing makeup valve.

Makeup Valve Flow Capacities – m <sup>3</sup> /hr		
Pressure at Valve Inlet while flowing–kPa	1" Diameter Valve	2" Diameter Valve
69	13	20
138	18	27
207	21	33
276	24	36
345	27	38

**NOTE**

- If makeup water pressure exceeds 345 kPa, use pressure reducer ahead of valve.
- For flow requirements exceeding the above limitations, use multiples of the same size valve.

NC8401 – NC8409

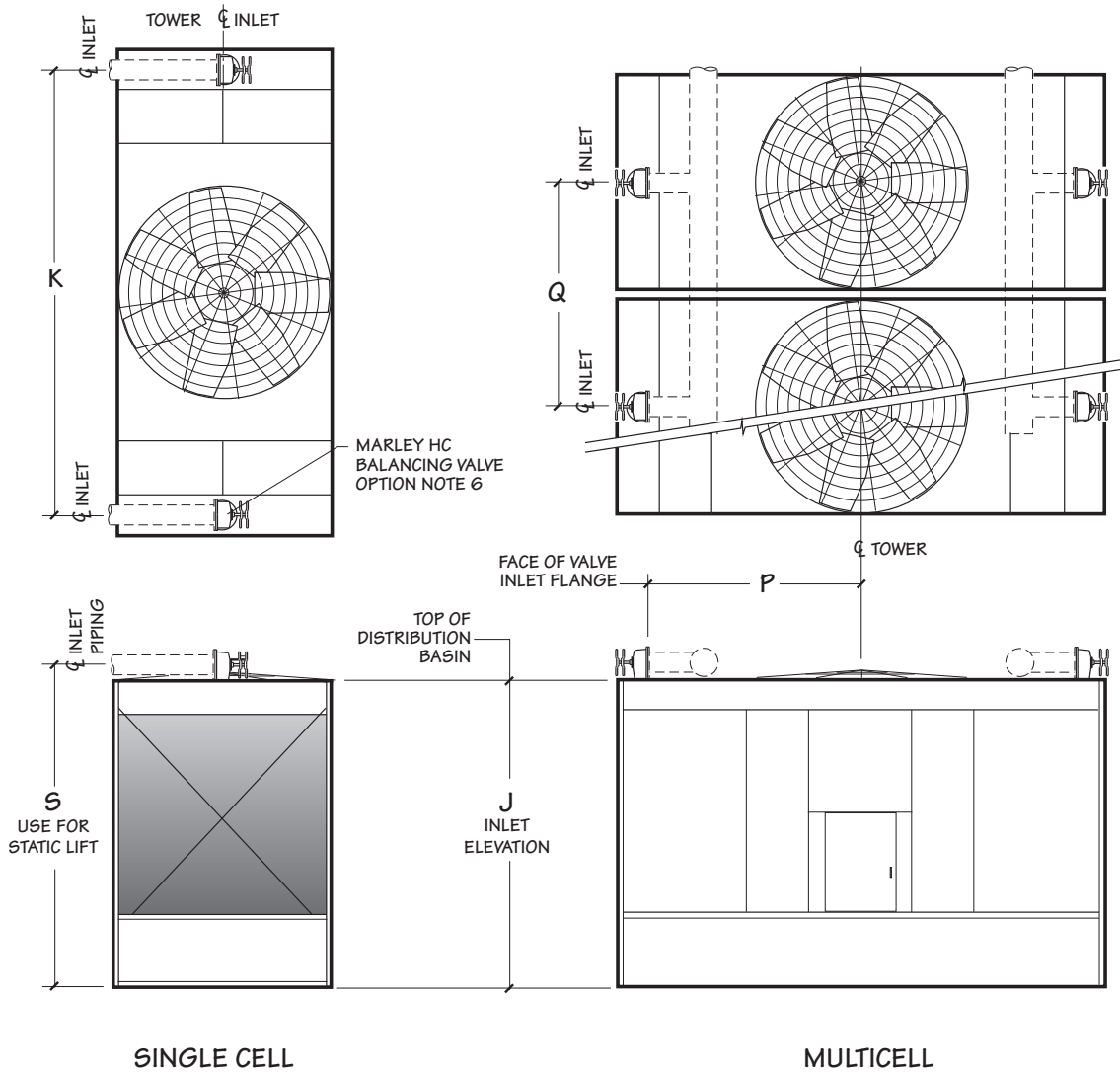

Model	Dimensions					Fan Diameter	Inlet Diameter
	J	K	S	P	Q		
NC8401	2972	3378	3183	1600	2076	72"	2 at 6"
NC8402	2972	3785	3183	1803	2648	84"	2 at 6"
NC8403	3488	4890	3720	2356	2648	84"	2 at 8"
NC8405	3488	5423	3720	2623	3105	108"	2 at 8"
NC8407	3488	5813	3720	2818	3715	120"	2 at 8"
NC8409	3488	6185	3770	2985	4324	144"	2 at 10"



NC8410 – NC8422

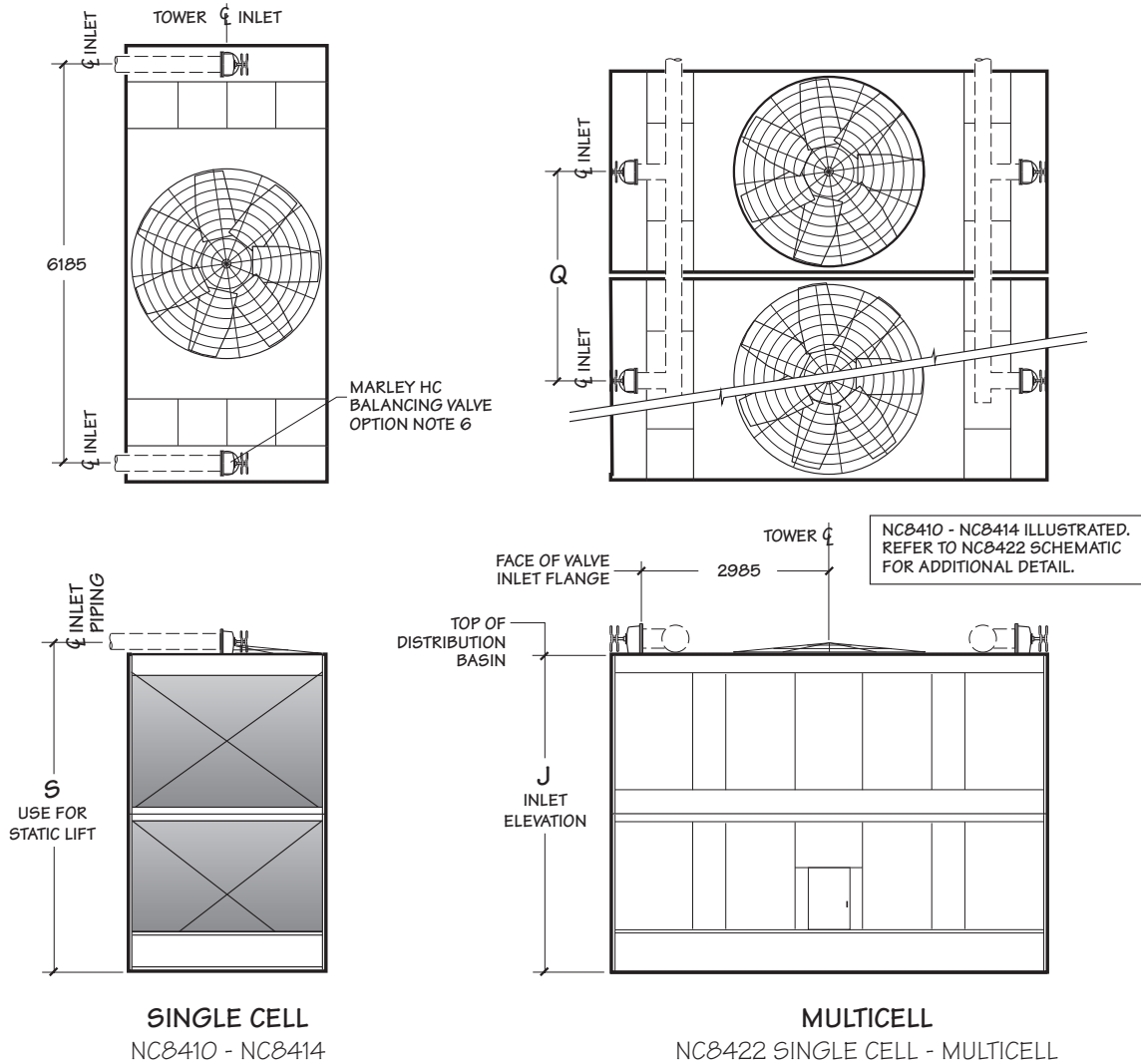

Model	Dimensions			Fan Diameter	Inlet Diameter
	J	S	Q		
NC8410	4724	5004	3715	132"	2 at 10"
NC8411	5578	5861	3715	132"	2 at 10"
NC8412	5578	5961	4324	144"	2 at 10"
NC8413	6725	6995	3715	132"	2 at 10"
NC8414	6725	6995	4324	144"	2 at 10"
NC8422	6725	7058	6922	228"	2 at 14"

NOTE

- 1 Use this bulletin for preliminary layouts only. Obtain current drawings from your Marley sales representative.
- 2 Pumping head contributed by the tower is static lift "S". Add your system dynamic pipe losses for total.
- 3 The tower will support the vertical weight of piping shown within the plan area of the tower only. All piping loads, including thrust and lateral loads of riser and horizontal piping must be supported independent of the tower. See inlet piping drawings for details.
- 4 All piping and supports—and their design—are by others.
- 5 Allow adequate clearance for entry to tower access doors and safe use of optional ladder. Refer to appropriate Marley drawings.
- 6 You may choose to use 90° short radius flanged elbows in place of HC balancing valves on single-cell towers where inlet piping is balanced for equal flow. Pipe elevation remains as shown.

NC8401 – NC8409

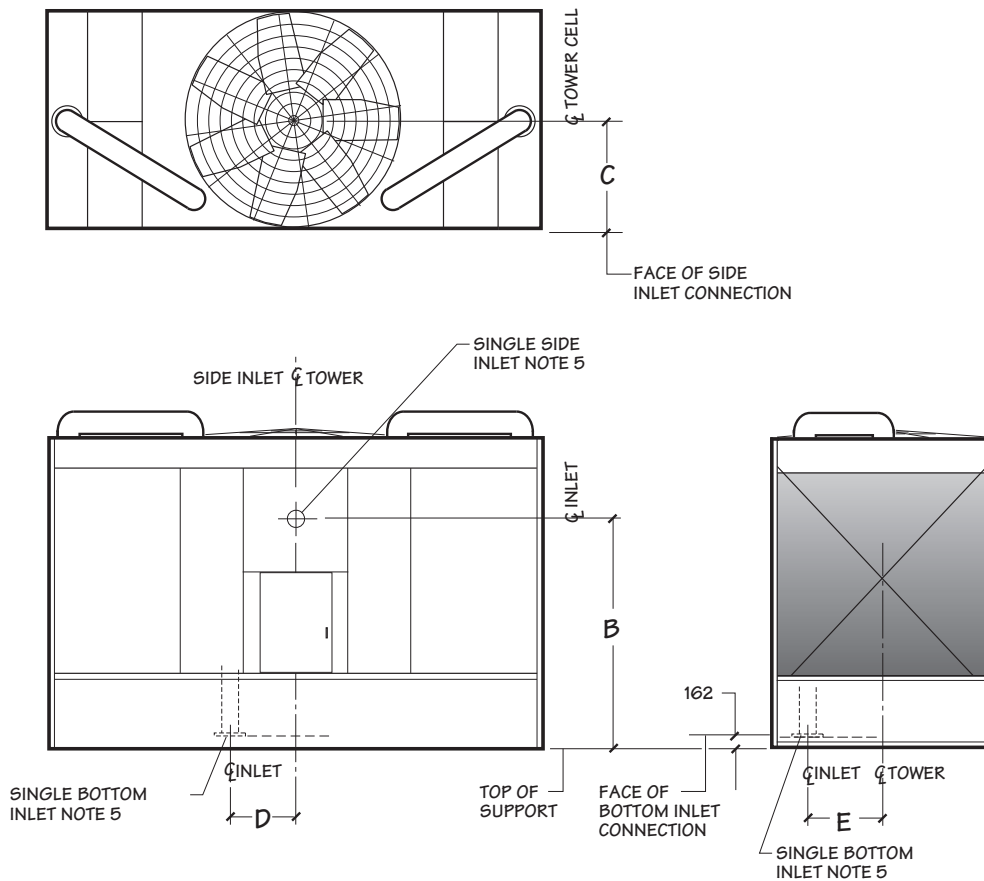

Model	Dimensions				Inlet Diameter
	B	C	D	E	
NC8401	2297	992	na	na	6"
NC8402	2302	1545	714	610	8"
NC8403	2834	1541	716	737	8"
NC8405	2808	1826	805	921	10"
NC8407	2786	2135	879	1270	10"
NC8409	2797	2438	886	1422	10"

NOTE

- 1 Use this bulletin for preliminary layouts only. Obtain current drawings from your Marley sales representative.
- 2 All external piping loads, including weight, thrust and lateral loads of riser and horizontal piping plus the weight of water in the internal riser must be supported independent of the tower. Internal riser adds additional vertical operating loads to external piping at the bottom inlet flange.
- 3 All piping and supports beyond the inlet connection—and their design—are by others.
- 4 Allow adequate clearance for entry to tower access doors and safe use of optional ladder. Refer to appropriate Marley drawings.
- 5 You may choose either a bottom inlet connection or a side inlet connection. The bottom inlet connects at the tower collection basin floor. Refer to appropriate Marley drawings.
- 6 Contact your Marley sales representative for the required pump head for single-inlet applications.
- 7 Weight of internal piping must be added to tower weights. Contact your Marley sales representative for combined tower weight information.

NC8410 – NC8414

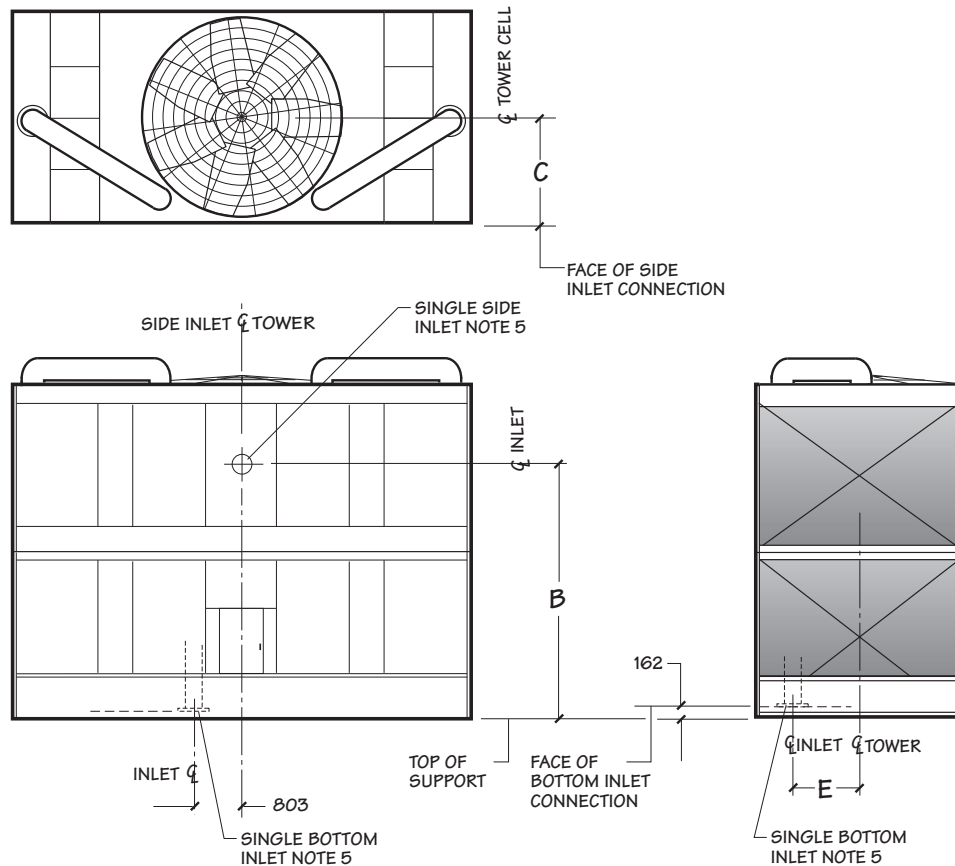

Model	Dimensions			Inlet Diameter
	B	C	E	
NC8410	4051	2221	1372	10"
NC8411	4915	2221	1372	12"
NC8412	4915	2502	1675	12"
NC8413	6061	2221	1372	12"
NC8414	6061	2502	1675	12"

NOTE

- 1 Use this bulletin for preliminary layouts only. Obtain current drawings from your Marley sales representative.
- 2 All external piping loads, including weight, thrust and lateral loads of riser and horizontal piping plus the weight of water in the internal riser must be supported independent of the tower. Internal riser adds additional vertical operating loads to external piping at the bottom inlet flange.
- 3 All piping and supports beyond the inlet connection—and their design—are by others.
- 4 Allow adequate clearance for entry to tower access doors and safe use of optional ladder. Refer to appropriate Marley drawings.
- 5 You may choose either a bottom inlet connection or a side inlet connection. The bottom inlet connects at the tower collection basin floor. Refer to appropriate Marley drawings.
- 6 Contact your Marley sales representative for the required pump head for single-inlet applications.
7. Weight of internal piping must be added to tower weights. Contact your Marley sales representative for combined tower weight information.

NC8401 – NC8414

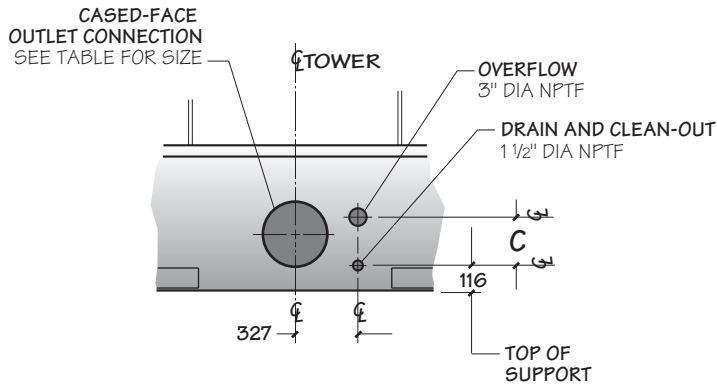

**DRAIN AND OVERFLOW CONNECTION  
OPTION**

**NOTE**

- Standard overflow is a 4" dia. standpipe in the collection basin floor. The standpipe removes for flush-out and draining.

Model	Dimensions		
	A	B	C
NC8401	254	1019	206
NC8402	254	1305	206
NC8403	286	1305	227
NC8405	286	1534	227
NC8407	286	1838	227
NC8409	286	2143	227
NC8410	286	1838	292
NC8411	286	1838	338
NC8412	286	2143	338
NC8413	286	1838	338
NC8414	286	2143	338

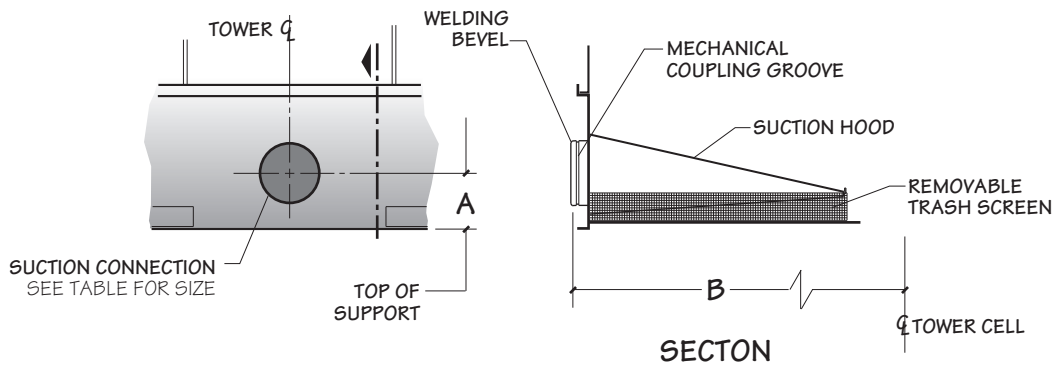

**CASED-FACE OUTLET CONNECTION**

NC8401 – NC8414

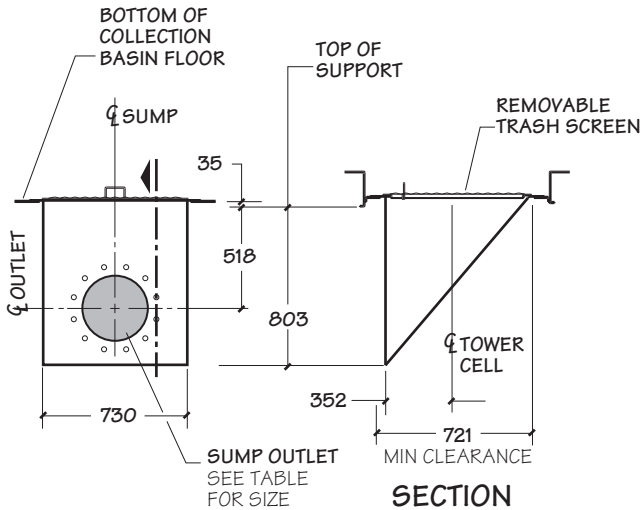

**DEPRESSED SIDE-OUTLET  
SUMP CONNECTION**  
STAINLESS STEEL OR FRP

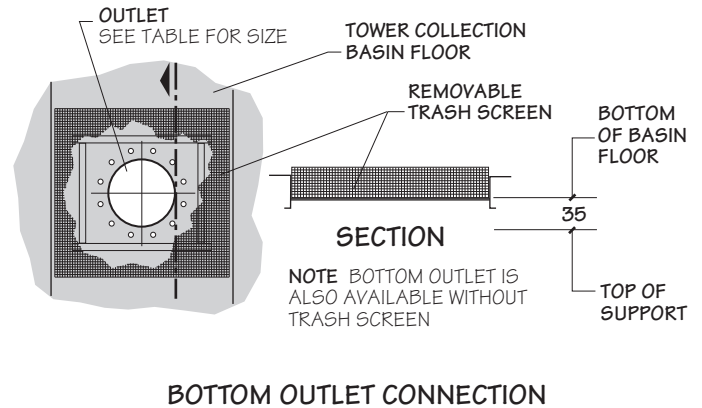

**BOTTOM OUTLET CONNECTION**

Maximum Flow Per Outlet Diameter m <sup>3</sup> /hr												
Outlet Type	Flow Type	Model	Outlet Diameter									
			4"	6"	8"	10"	12"	14"	16"	18"	20"	24"
Bottom	pump flow w/ anti-vortex plate or gravity flow w/ or w/o anti-vortex plate	NC8401 thru NC8405	35.6	80.6	143	225.5	320.9	392.7	519	569.9	754.5	912.8
		NC8407 thru NC8414	37.9	86.3	152.8	241	342.9	419.7	554.6	718.6	869.7	1112
	pump flow w/o anti-vortex plate	NC8401 thru NC8414	16.1	36.8	65.2	102.8	146.2	179	236.7	306.4	380.7	552.6
Sump	pump flow w/ anti-vortex plate or gravity flow w/ or w/o anti-vortex plate	NC8401 thru NC8405		204.4	362.3	571.2	812.6	973				
		NC8407 thru NC8414		204.4	362.3	571.2	812.6	994.6				
	pump flow w/o anti-vortex plate	NC8401 thru NC8414		143	253.5	400	568.9	696.1				
Cased-Face Outlet	pump flow only	NC8401 thru NC8405		204.4	362.3	571.2	812.6					
		NC8407 thru NC8414		204.4	362.3	571.2	812.6	994.6				

**NOTE**

- Flow rate may be limited by the maximum flow for unit size.
- For gravity-flow situations (as to an indoor tank), use bottom outlet or depressed side outlet sump. Cased-face outlet is not recommended for gravity flow.
- Flow limits are the outlet capacities per outlet based on the design operating water level—216mm above the top of support on models NC8401 through NC8405—241mm on NC8407 thru NC8414.

NC8422

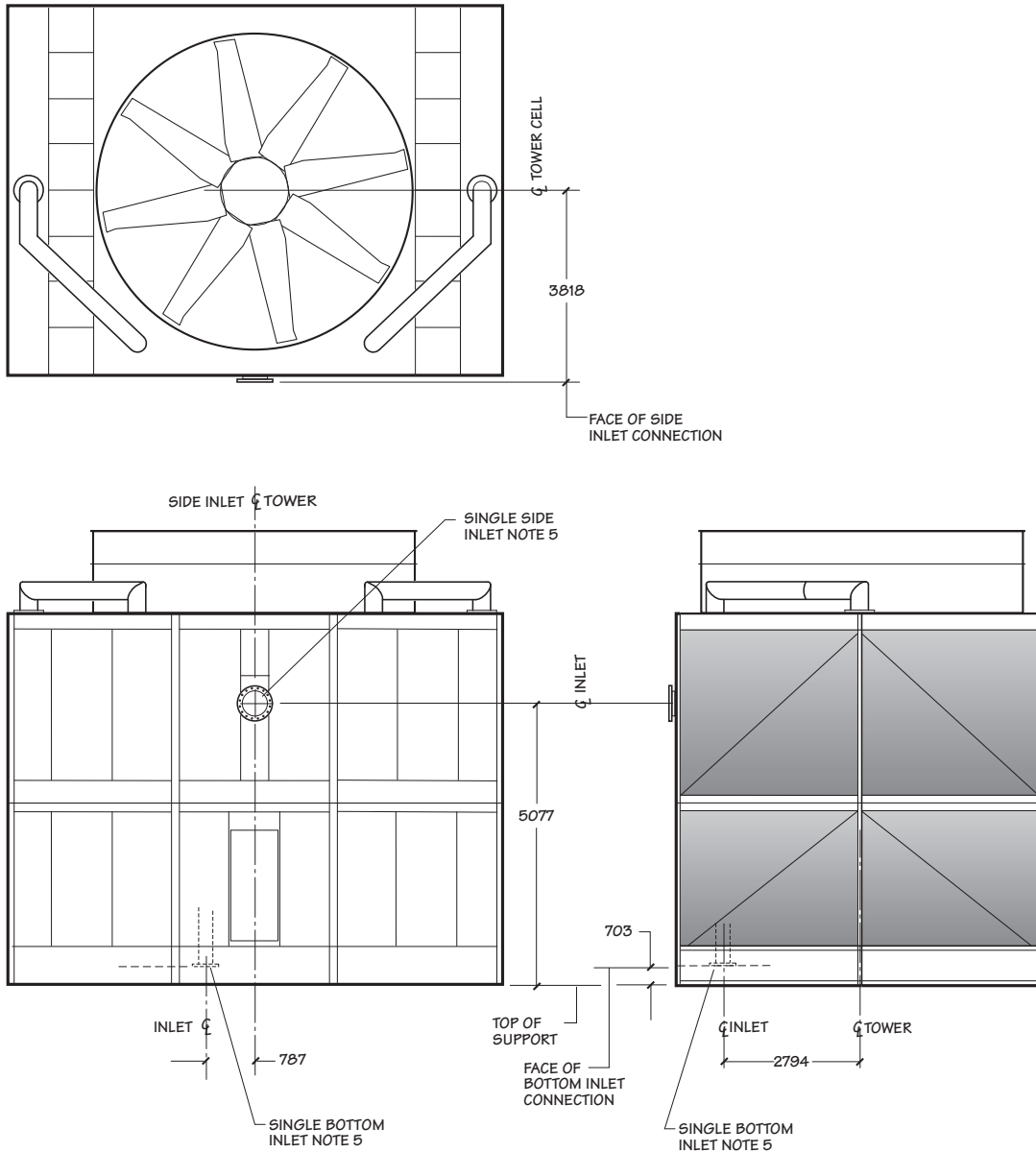

NOTE

- 1 Use this bulletin for preliminary layouts only. Obtain current drawings from your Marley sales representative.
- 2 All external piping loads, including weight, thrust and lateral loads of riser and horizontal piping plus the weight of water in the internal riser must be supported independent of the tower. Internal riser adds additional vertical operating loads to external piping at the bottom inlet flange.
- 3 All piping and supports beyond the inlet connection—and their design—are by others.
- 4 Allow adequate clearance for entry to tower access doors and safe use of optional ladder. Refer to appropriate Marley drawings.
- 5 You may choose either a bottom inlet connection or a side inlet connection. The bottom inlet connects at the tower collection basin floor. Refer to appropriate Marley drawings.
- 6 Contact your Marley sales representative for the required pump head for single-inlet applications.
- 7 Weight of internal piping must be added to tower weights. Contact your Marley sales representative for combined tower weight information.

NC8422

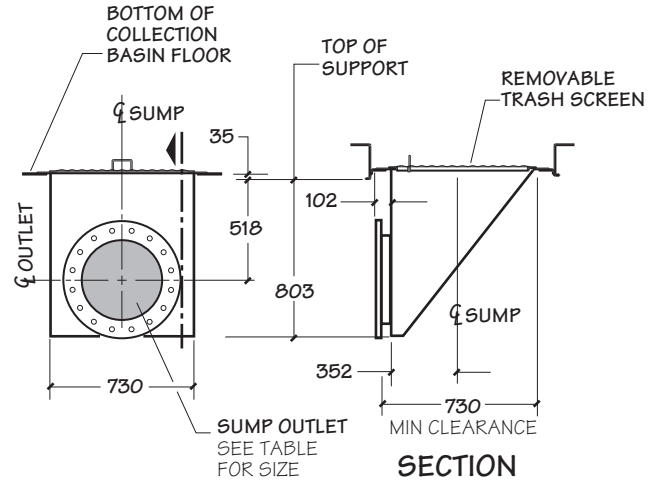
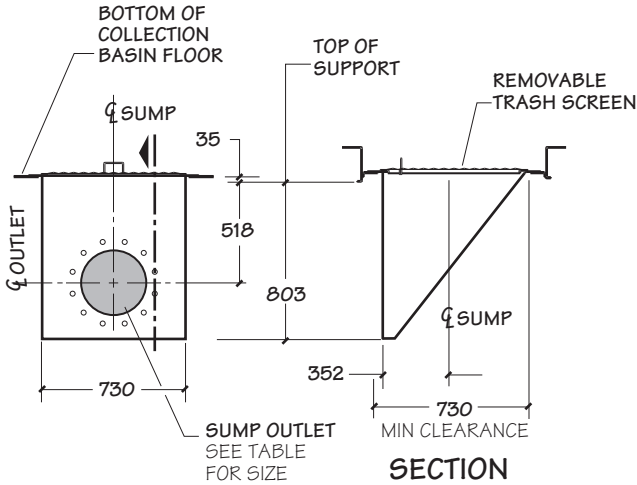

DEPRESSED SIDE-OUTLET  
FLANGED SUMP CONNECTION  
16" AND 18" DIAMETER

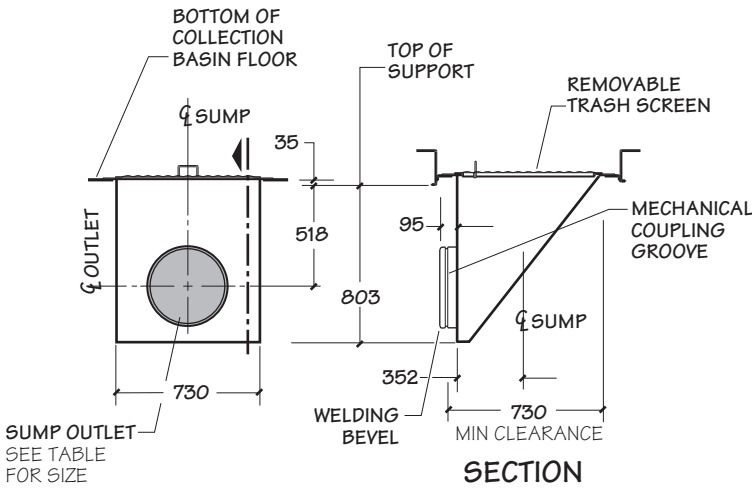

DEPRESSED SIDE-OUTLET  
BEVEL - GROOVED CONNECTION  
16" AND 18" DIAMETER

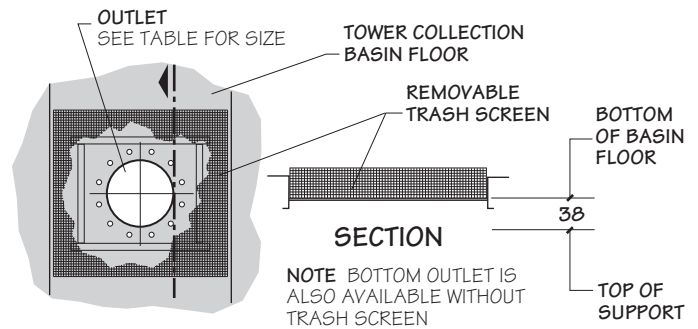

BOTTOM OUTLET CONNECTION

		Maximum Flow Per Outlet Diameter m <sup>3</sup> /hr								
Outlet Type	Flow Type	Outlet Diameter								
		6"	8"	10"	12"	14"	16"	18"	20"	24"
Bottom	pump flow w/ anti-vortex plate or gravity flow w/ or w/o anti-vortex plate		172	271	386	472	624	809	1004	1458
Sump	pump flow with anti-vortex plate	204	362	571	813	995	1314	1759		

NOTE

- Flow rate may be limited by the maximum flow for unit size.
- 16" and 18" sumps are only available in stainless steel.
- For gravity-flow situations (as to an indoor tank), use bottom outlet.
- Flow limits are the outlet capacities per outlet based on 295mm design operating water level.

NC8401 – NC8414

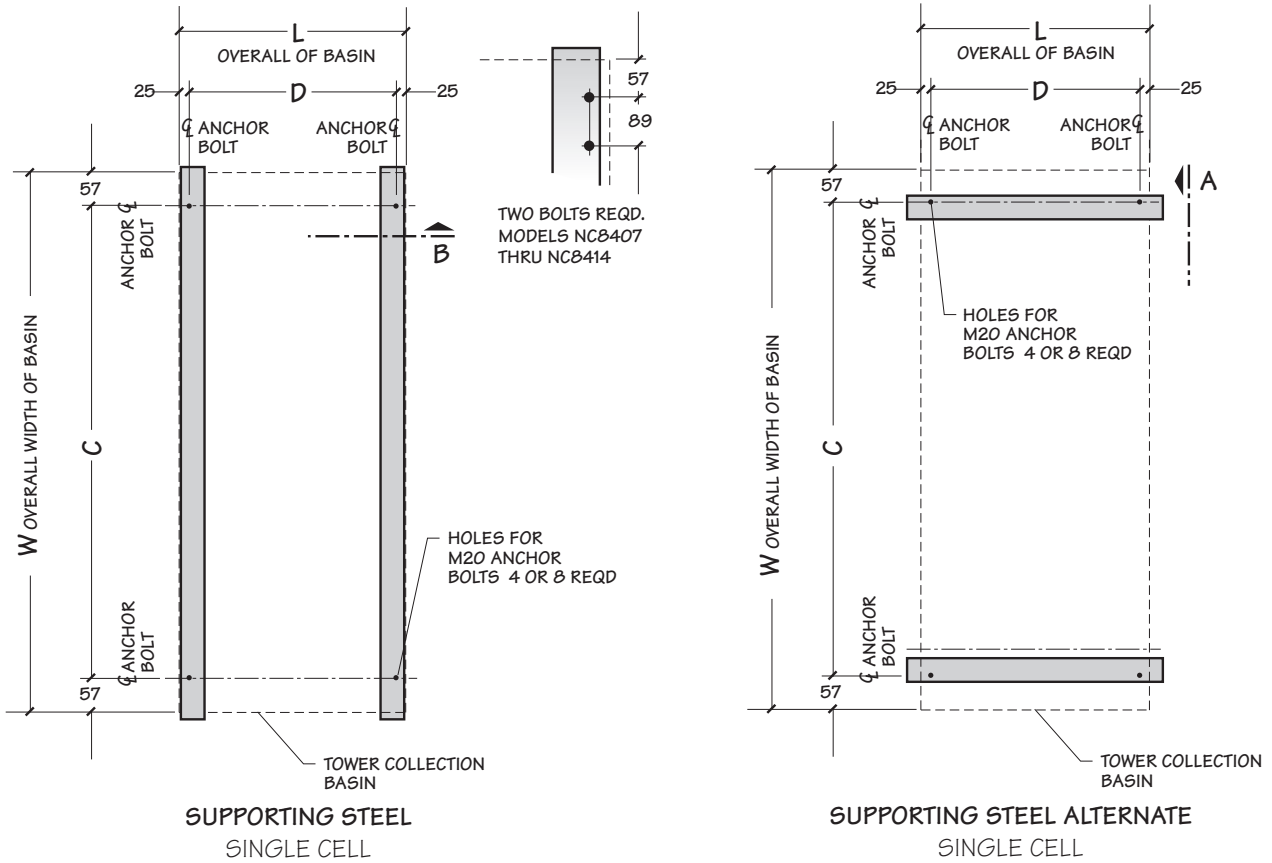

Model	Dimensions				Design Operating Weight/Cell kg	Design Operating Load at Anchor kg
	W	L	C	D		
NC8401	3912	1988	3797	1937	3542	886
NC8402	4318	2559	4204	2508	4613	1153
NC8403	5537	2559	5423	2508	7172	1793
NC8405	6071	3016	5956	2965	8932	2233
NC8407	6401	3626	6287	3575	11260	2815
NC8409	6833	4235	6718	4185	13614	3403
NC8410	6833	3626	6718	3575	15238	3809
NC8411	6833	3626	6718	3575	16935	4234
NC8412	6833	4235	6718	4185	19466	4866
NC8413	6833	3626	6718	3575	19030	4758
NC8414	6833	4235	6718	4185	21933	5483

NOTE

- 1 Use this bulletin for preliminary layouts only. Obtain current drawings from your Marley sales representative for final design.
- 2 Purchaser to provide tower support complete with holes and anchor bolts. Do not use studs! Anchor points must be framed flush and level at top.
- 3 Design operating weight occurs with collection basin full to overflow level. Actual operating weight varies with m<sup>3</sup>/hr and piping scheme.
- 4 Tower may be placed on a flat concrete slab. Side outlet and optional side drain and overflow must be specified. See pages 13 and 18 and consult your Marley sales representative.
- 5 Tower may be supported from piers at each anchor bolt location, as a support alternative.
- 6 Dimensions between anchor bolts may vary depending on the number of cells and options. Dimensions shown are for a standard two cell arrangement. Obtain current drawings from your Marley sales representative for final dimension.



NC8401 – NC8414

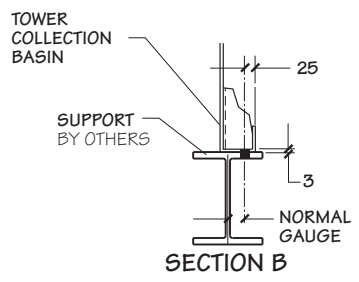
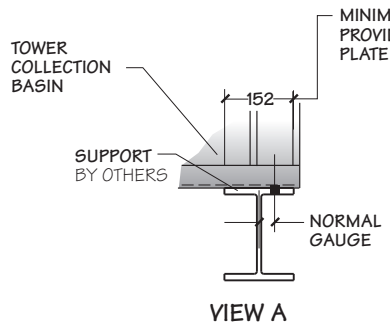
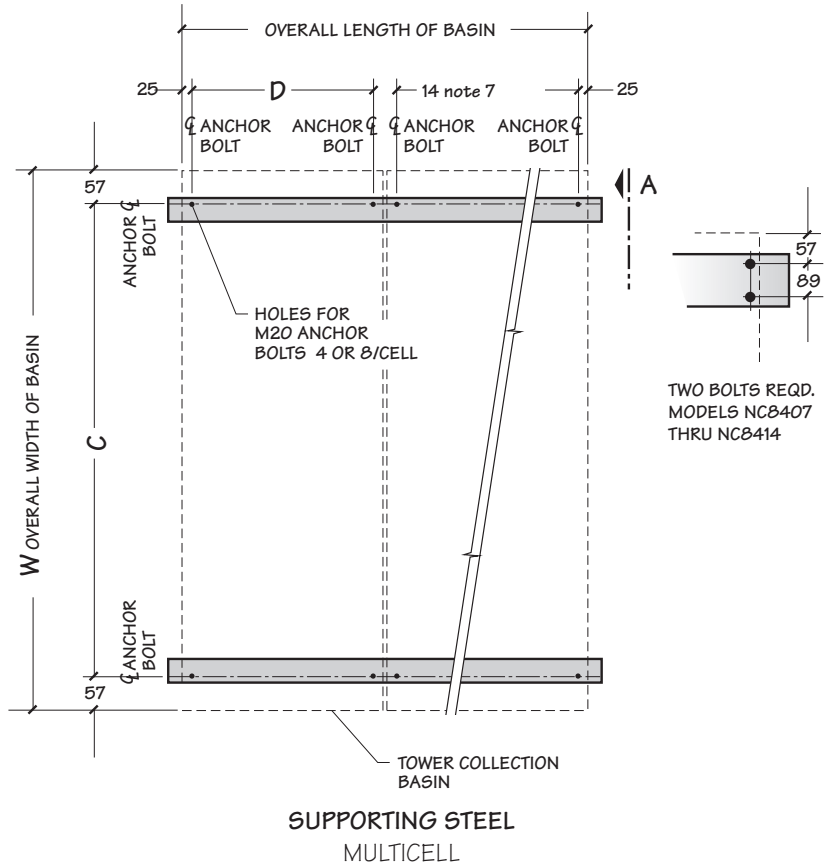

NOTE

- 1 Use this bulletin for preliminary layouts only. Obtain current drawings from your Marley sales representative for final design.
- 2 Purchaser to provide tower support complete with holes and anchor bolts. Do not use studs! Anchor points must be framed flush and level at top.
- 3 Design operating weight occurs with collection basin full to overflow level. Actual operating weight varies with m<sup>3</sup>/hr and piping scheme.
- 4 Tower may be placed on a flat concrete slab. Side outlet and optional side drain and overflow must be specified. See pages 13 and 18 and consult your Marley sales representative.
- 5 Tower may be supported from piers at each anchor bolt location, as a support alternative.
- 6 Dimensions between anchor bolts may vary depending on the number of cells and options. Dimensions shown are for a standard two cell arrangement. Obtain current drawings from your Marley sales representative for final dimension.

NC8422

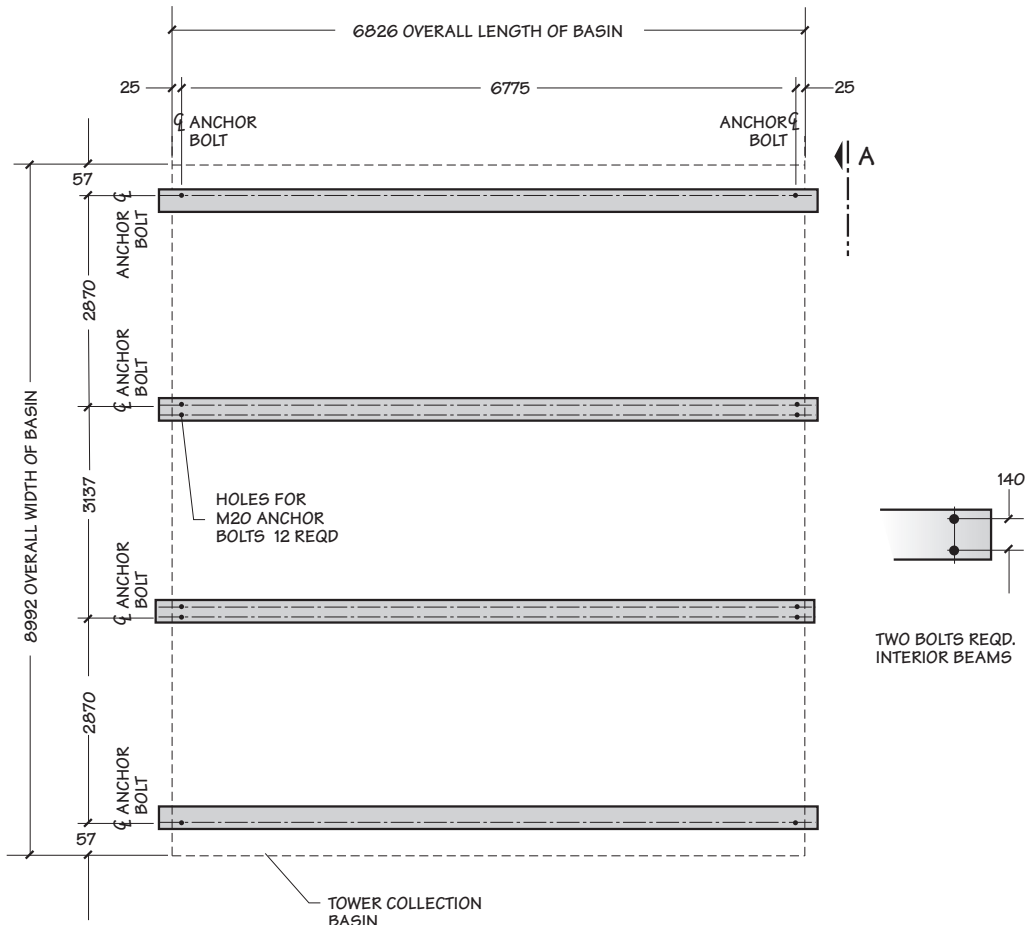

**SUPPORTING STEEL**  
SINGLE CELL

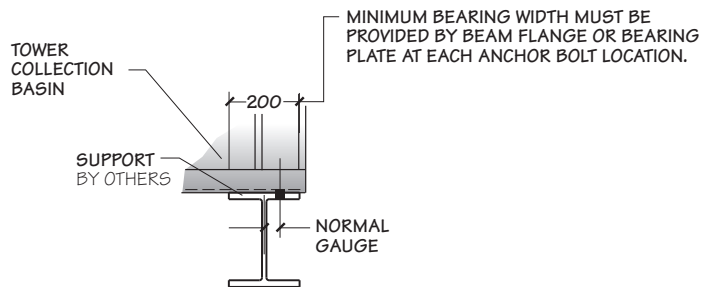

VIEW A

NC8422

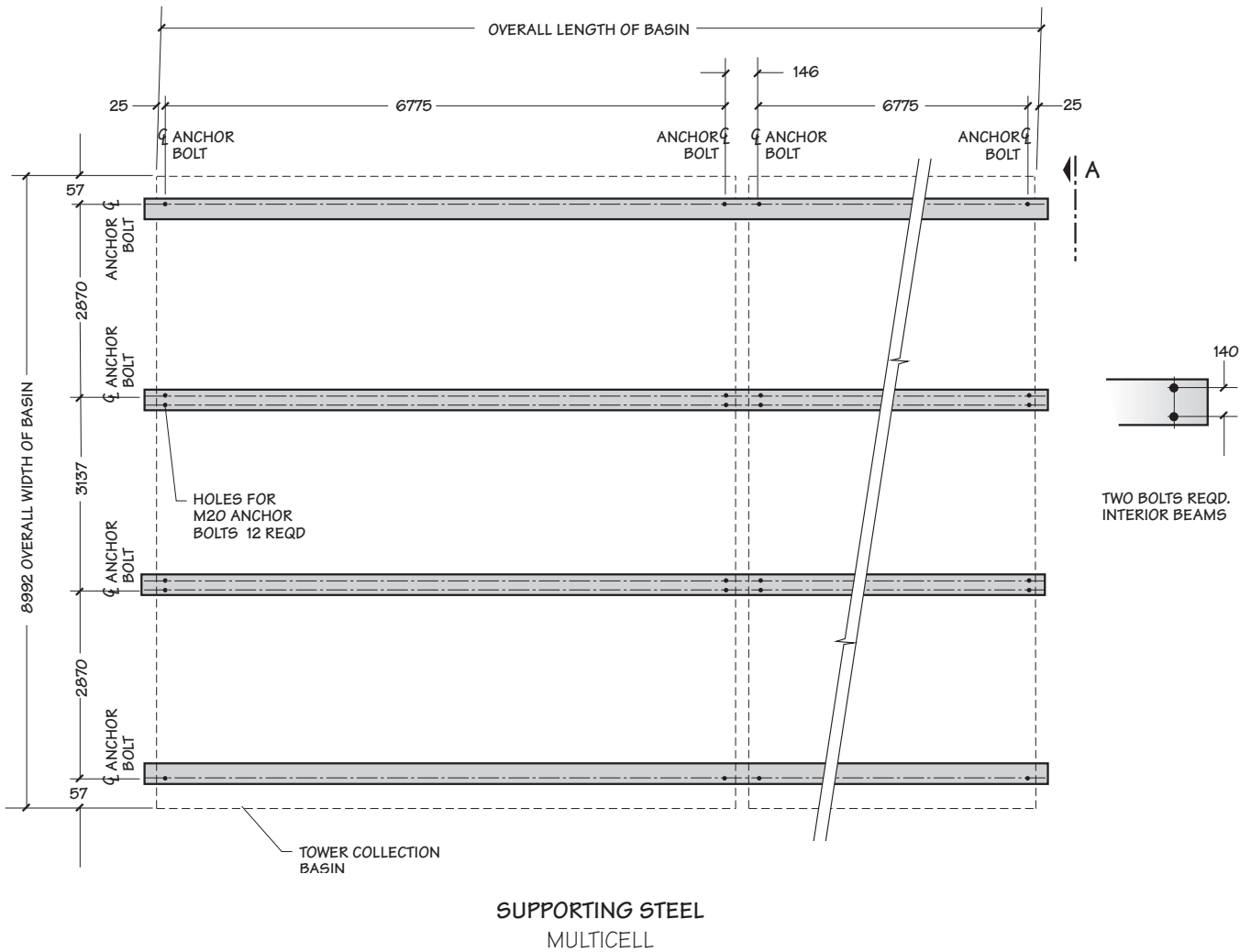

NOTE

- 1 Use this bulletin for preliminary layouts only. Obtain current drawings from your Marley sales representative for final design.
- 2 Purchaser to provide tower support complete with holes and anchor bolts. Do not use studs! Anchor points must be framed flush and level at top.
- 3 Design operating weight occurs with collection basin full to overflow level. Actual operating weight varies with gpm and piping scheme.
- 4 Tower may be supported from piers at each anchor bolt location, as a support alternative. Consult your Marley sales representative for additional details.
5. Dimensions between anchor bolts may vary depending on the number of cells and options. Dimensions shown are for a standard two cell arrangement. Obtain current drawings from your Marley sales representative for final dimension.

NC8401 - NC8414

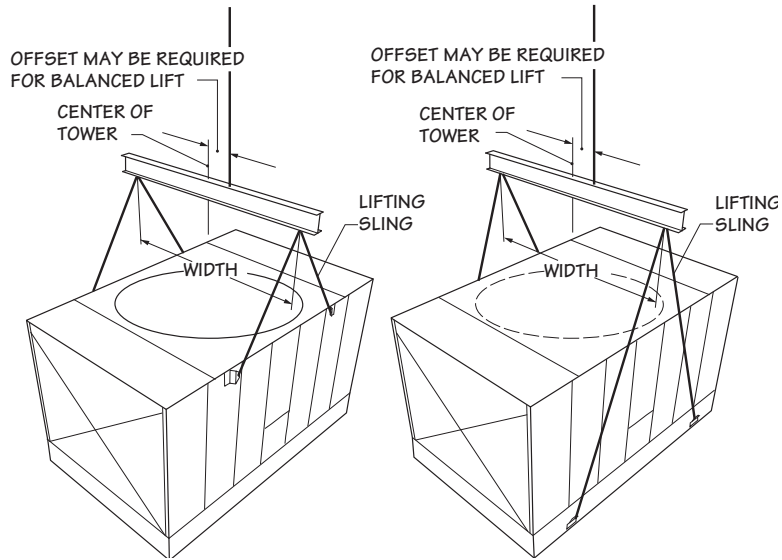

Model	Width	Minimum Sling Length
NC8401	2000	2000
NC8402	2600	2000
NC8403	2600	2500
NC8405	3100	2500
NC8407	3700	3000
NC8409	4300	6000
NC8410 Top	3700	3000
NC8410 Bottom	3700	5000
NC8411 Top	3700	3000
NC8411 Bottom	3700	6000
NC8412 Top	4300	3000
NC8412 Bottom	4300	6000
NC8413 Top	3700	3000
NC8413 Bottom	3700	6000
NC8414 Top	4300	3000
NC8414 Bottom	4300	6000

**NOTE**

- All hoisting clip holes are 32mm.
- On multicell tower installations, overall length of shackle pins should not exceed 134mm.
- For overhead lifts or where additional safety is required, add slings beneath the tower unit.

NC8422

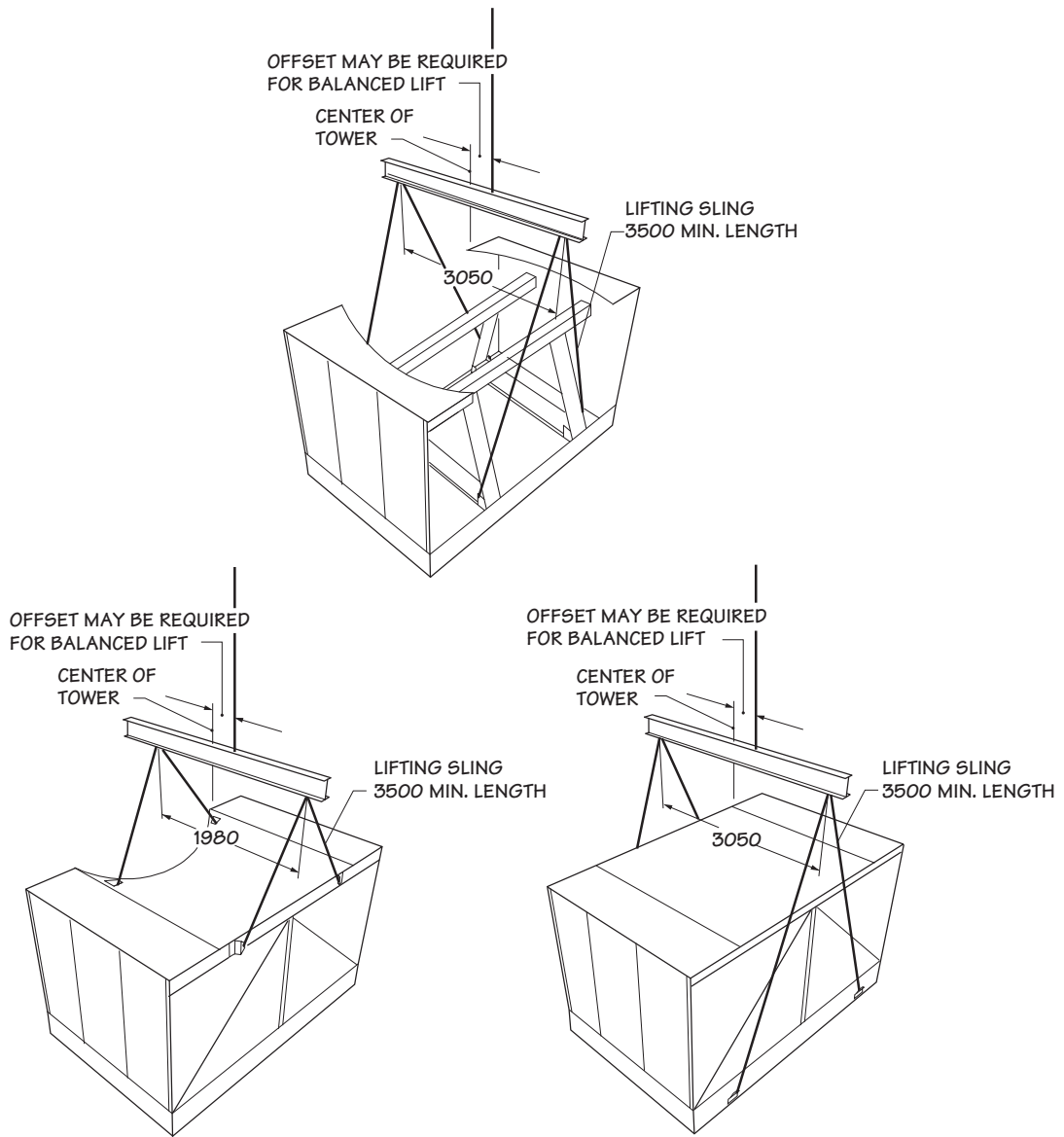

**NOTE**

- All hoisting clip holes are 32mm.
- Overall length of shackle pins should not exceed 65mm.
- For overhead lifts or where additional safety is required, add slings beneath the tower unit.

NC8401 - NC8414

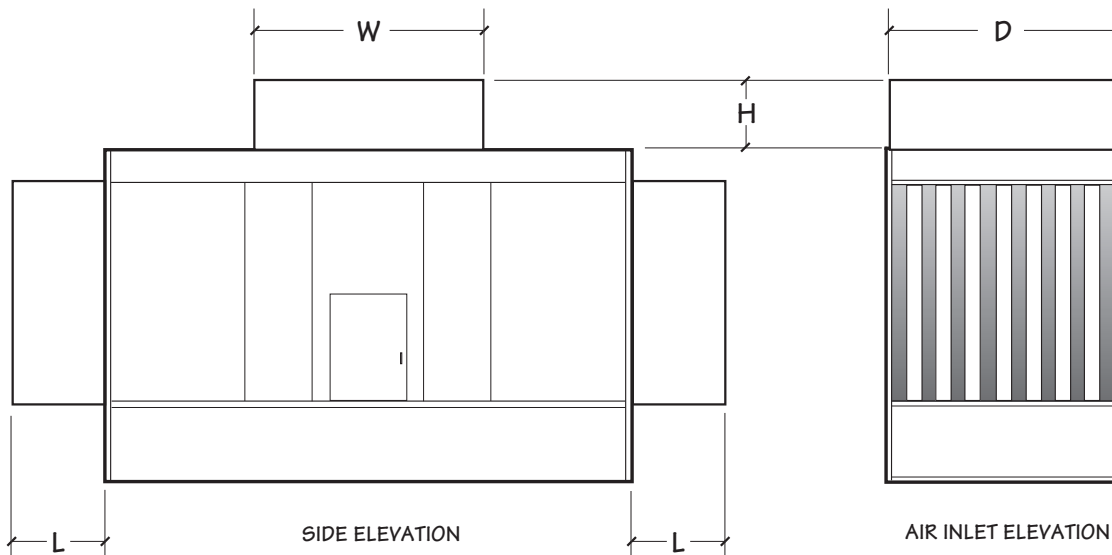

Model	Dimensions				Add To Design Operating Weight kg	
	L	W	D	H	Discharge Attenuator	Inlet Attenuators
NC8401	692	2083	1867	686	281	691
	1384	2083	1867	1372	563	1381
NC8402	692	2394	2438	686	351	848
	1384	2394	2438	1372	702	1696
NC8403	692	2394	2438	686	351	953
	1384	2394	2438	1372	702	1906
NC8405	692	2972	2896	686	477	1116
	1384	2972	2896	1372	953	2232
NC8407	692	3261	3505	686	633	1413
	1384	3261"	3505	1372	1266	2826
NC8409	692	3896	4115	686	733	1591
	1384	3896	4115	1372	1466	3182
NC8410	692	3578	3505	686	709	2287
	1384	3578	3505	1372	1419	4574
NC8411	692	3578	3505	686	709	2523
	1384	3578	3505	1372	1419	5046
NC8412	692	3896	4115	686	733	2845
	1384	3896	4115	1372	1466	5690
NC8413	692	3578	3505	686	709	2910
	1384	3578	3505	1372	1419	5821
NC8414	692	3869	4115	686	733	3198
	1384	3896	4115	1372	1466	6397

NOTE

- 1 Use this bulletin for preliminary layouts only. Obtain current drawings from your Marley sales representative. All table data is per cell.
- 2 Attenuators are field installed by others with hardware provided by Marley
- 3 Attenuators are supported by the tower. Additional support not required.
- 4 Discharge attenuators are not available for NC models with velocity recovery cylinders.



---

**SPX COOLING TECHNOLOGIES UK LTD**

3 KNIGHTSBRIDGE PARK, WAINWRIGHT ROAD  
WORCESTER WR4 9FA UK  
44 1905 750 270 | [ct.fap.emea@spx.com](mailto:ct.fap.emea@spx.com)  
[spxcooling.com](http://spxcooling.com)

uk\_TECH-NC-23 | ISSUED 1/2023

© 2009-2023 SPX COOLING TECH, LLC | ALL RIGHTS RESERVED

In the interest of technological progress, all products are subject to design and/or material change without notice.

