

# Downtime Instructions

MECHANICAL DRAFT COOLING TOWERS

uk\_Z0238848\_C ISSUED 8/2017

READ AND UNDERSTAND THIS MANUAL PRIOR TO OPERATING OR SERVICING THIS PRODUCT



---

## Preface

Proper preventive maintenance of equipment during downtime will assure trouble-free start-up. This manual gives suggested procedures for protection of tower mechanical equipment for downtime ranging from seasonal to extended downtime in two different periods. The periods increase in length and in extent of protection.

SPX Cooling Technologies offers these suggestions as being representative of good practice. Warranty of condition after downtime and or amendment to specific contract warranties is not intended.

---

### Warning

***Never start motor on fan drive without first making sure that there will be no interference with free rotation of the fan, driveshaft, or V-belt.***

---

## Seasonal Downtime

### Fans, Driveshafts, and V-belts

Maintain freedom for fan rotation. Do not operate if snow, ice or other obstruction will interfere with rotation.

### Geareducers

---

### Note

***The 2000, 2250 and 2800 Geareducer models have 5-year synthetic oil change intervals. To maintain five-year change intervals, use only oil designed specifically for these Geareducer models. Proceed to step 2 below. If, after five years, turbine-type mineral oil is used, then proceed starting with step 1. Refer to Geareducer User Manual for oil recommendations and further instructions.***

1. At start of down-time period, operate Geareducer until oil is warm (50°C) and change the oil. See Lubrication section of the Geareducer Service Manual for instructions on changing oil. Allow freedom for fan to windmill.
2. Each month, drain any water condensate from the lowest point of the Geareducer and its oil system. Check the oil level and add oil if necessary. Operate the Geareducer a minimum of 20 minutes to recoat the interior surfaces with oil.
3. To return to operation, drain off any condensate, check oil level and add oil as necessary to establish required oil level. Change oil at normal recommended interval, accounting for downtime as operating time.

### **Bearing Housing, Oil Lubricated**

1. At start of downtime period, operate bearing housing until oil is warm (35°C) and change the oil. See the Lubrication section of the Bearing Housing User Manual for instructions on changing oil. Allow fan freedom to windmill.
2. Each month drain any water condensate from the lowest point of the bearing housing. Add oil if necessary to maintain oil level.
3. To return to operation, drain any water condensate, check oil level and add oil as necessary to establish required level. Change oil at normal recommended interval, accounting for downtime as operating time.

### **Fan Motors**

1. At start of shutdown, clean all air passages and lubricate bearings. See the motor manufacturer's instructions. Motors with sealed bearings do not require lubrication maintenance.
2. Each month, run motor until it has reached operating temperature. Space heaters are recommended. If heaters are used, motors need be run only 20 minutes minimum. Refer to the "**Fan Motor**" User Manual for additional information.

---

### **Note**

***Higher density of cold air at fan increases motor horsepower. If motor overloads will not allow fan motor operation at high speed in forward direction, one of the following might be done:***

- If overloads are adjustable, set at a higher value (+15%) for cold weather operation.
  - Operate motor (fan) in reverse (reverse any 2 leads).
  - Operate two speed motor at low speed.
3. Enclose motors or cover to protect from wet-down of a fire protection system or rainfall.
  4. To return motors into operation, clean all air passages, remove temporary vented cover and lubricate bearings. Motors with sealed bearings do not require lubrication maintenance.

---

## Extended Downtime (beyond 3 months)

### Fans and Driveshafts

Maintain freedom of rotation. Do not operate if snow, ice or other obstructions will interfere with rotation.

### V-Belt Drives

1. At start of down time, remove and store belts in a cool, dry, dark room. Clean and coat sheave grooves with rust preventative, lacquer or paint.
2. Remove rust preventative from sheaves before reinstalling belts.

### Geareducers with External Gauge and Drain Lines

#### At Start of Downtime Period:

1. Operate Geareducer until oil is warm (50°C) and drain the oil. Completely replacing the oil may only be required for Geareducers using mineral oil. See Geareducer note on page 2 for further information.
2. Fabricate and install an expansion chamber on the sight glass riser; see Figure 1. The figure shows the proportions of the expansion chamber and its relationship in elevation to the oil level. The purpose is to allow for expansion of the oil due to temperature change from that at the time of filling without causing it to overflow at the fan shaft closure. Smaller chambers may satisfy smaller Geareducer applications, but the 100mm depth and elevation relationships should be maintained.

Expansion volumes required by Geareducers most likely to require this type of storage are listed by basic model number:

Models 3400, 36, 38, 3600 and 4000 \_\_\_\_ 5.7 liter

Models 2700, 3000 and 32.2 \_\_\_\_\_ 3.8 liter

Models 2200, 2250, 2400 and 2800 \_\_\_\_ 2.9 liter

The vent may be removed from the top of the oil level gauge to be used as a vent for the expansion chamber. The chamber must be vented.

3. Remove the vent or vent line from the Geareducer.
4. Fill the Geareducer with oil until it rises just to the bottom of the vent hole in the top (cover) of the Geareducer. Use one of the oils listed in the appropriate Geareducer User Manual.
5. Smaller Geareducers than listed may be stored this way, provided the basic requirement of submerging the top-most bearing in oil and the requirements above are satisfied.
6. Plug the vent on the Geareducer with a 1/2" pipe plug. Model 2200, 2250 and 2400 requires a 1/4" plug.

An ordinary standpipe to 15 cm minimum elevation above oil level may be substituted for the chamber with the possibility of oil spillage from Geareducer fan shaft closure due to wide temperature fluctuations (see note on page 6). Oil level must be monitored and kept at vent hole level, shown here, at all times.

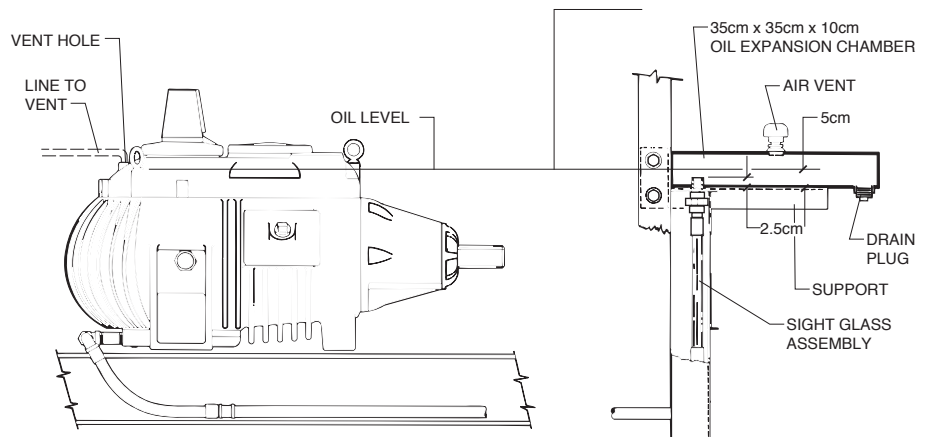

**Figure 1**

7. Open the disconnect switch to the fan motor, and tag it to prevent running the Geareducer while it is full of oil. Allow Geareducer freedom to windmill. (See note on page 6.)
8. Quarterly, drain water condensate at lowest point of oil system at drain in expansion chamber, check and make up oil level and rotate input shaft at least 15 revolutions. Allow to windmill.

#### At End of Downtime Period

1. Drain oil to operating level.
2. Remove the pipe plug from the Geareducer vent hole and reinstall the vent fitting or line.
3. Remove the tag and close the disconnect switch to the fan motor. The expansion chamber may be removed .
4. If downtime was 6 months or longer, check to be sure there is no obstruction to rotation and run the fan motor until Geareducer until oil is warm (50°C). Stop the Geareducer and change the oil. Changing oil may only be required for Geareducers using mineral oil. See Geareducer note on page 2 for further information.

#### Geareducers without External Gauge and Drain Lines

Use the same procedure as outlined for Geareducer with external gauge and drain lines. It will be necessary to install an external gauge and drain line or pipe and a riser which would permit mounting the expansion chamber outside the fan cylinder, see Figure 1.



### **Bearing Housings, Oil Lubricated**

1. At the start of the downtime period, operate bearing housing until oil is warm (35°C), then change the oil. See the lubrication section of the Bearing Housing User Manual for instructions.
2. Each quarter, drain any water condensate from the lowest point of the bearing housing. Add oil as necessary to maintain level. Allow to windmill. (see note on page 6.) Rotate 15 revolutions.
3. To return to operation, bring up to operating temperature and change the oil.

### **Fan Motors**

1. At start of downtime period, lubricate bearings. See motor manufacturer's instructions on lubrication. Does not apply to motors with sealed bearings.
2. Keep the motor temperature 5° F to 10° F above ambient temperature with the aid of space heaters or reduced voltage winding heating. Allow freedom to windmill.
3. Once each quarter, rotate motor shaft 15 revolutions.
4. Once each year, remove grease fill and relief plugs and lubricate motor bearings. **Do not** operate motor. Replace plugs. Does not apply to motors with sealed bearings.
5. Enclose motors or cover to protect from wet-down of a fire protection system or rainfall.
6. To return to operation, remove temporary covers and clean air passages. Remove grease fill and relief plugs and lubricate bearings. Operate the motor to purge excess grease and replace the plugs. See motor manufacturer's instructions on lubrication. Does not apply to motors with sealed bearings. Refer to the "**Fan Motor**" User Manual Z0239042 for additional information.

---

### **Note**

***The frequency of maintenance operations required by these instructions assumes sufficient wind velocity to cause some fan rotary motion (not necessarily fan spinning) at least once per month. This motion is required to reposition bearing, shaft and gear elements with respect to each other to allow the lubricant the greatest opportunity to protect these vital parts from corrosion. Any time a period of one month passes without wind-caused fan rotary motion, maintenance personnel should be alert to this fact and provide manual rotation of the drive line. At least 15 revolutions of the motor shaft is recommended.***

---

## General

**Fire Protection**—Protect dry wood towers against fire. Any flammable debris should be removed weekly. Wood towers may be wetted for fire protection. This may be done by providing some form of sprinkler system to wet the entire top of the tower. This should include the top structure inside the fan cylinder. Sprinkling should be avoided in freezing weather.

The sprinkler system must be designed in order not to cause direct water impingement on Geareducer shaft closures, the Geareducer vent, the Geareducer external oil system vent, and the electric motor shaft closures, air openings, vents and drains.

The fan motor(s) must be covered with a vented enclosure to avoid moisture entrapment. This is necessary to avoid excessively high humidity around the motors, and to avoid wide fluctuation in motor temperature that sprinkling would cause. The enclosure should cover any back stop or brake assembly mounted on, or connected to any part of the motor.

**During Freezing Weather**—Drain tower basins and all exposed piping including risers. Leave the drain and overflow valves open to prevent accumulation of rain water, snow or melted snow and ice.

**During Non-Freezing Weather**—It may be more convenient to keep normal water level in wood basins for short downtime periods to keep basins tight. Wood basins (over longer periods) and concrete and steel basins should be drained.

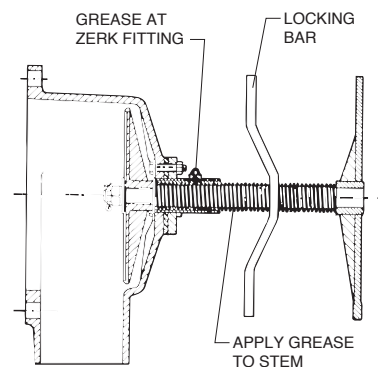

---

**Figure 2**

Flow Control Valves are to be left full open with locking bar locked. Apply grease through the zerk fitting to the stem-guide interface and coat the entire exposed stem with grease. NLGI #2 Lithium base grease is suggested. See Figure 2.

---

## Note

***Start-Up Preparation of a wood tower after a long dry shut-down should include thorough wetting before full operation.***

# Downtime Instructions

---

**SPX COOLING TECHNOLOGIES UK LTD**

3 KNIGHTSBRIDGE PARK, WAINWRIGHT ROAD  
WORCESTER WR4 9FA UK

44 1905 750 270 | [ct.fap.emea@spx.com](mailto:ct.fap.emea@spx.com)  
[spxcooling.com](http://spxcooling.com)

uk\_Z0238848\_C | ISSUED 8/2017

COPYRIGHT © 2016 SPX CORPORATION

In the interest of technological progress, all products are subject to design  
and/or material change without notice.

