

Softork™ MC coupling

INSTALLATION - OPERATION - MAINTENANCE

uk_Z0592740_B ISSUED 02/2019

READ AND UNDERSTAND THIS MANUAL PRIOR TO OPERATING OR SERVICING THIS PRODUCT.



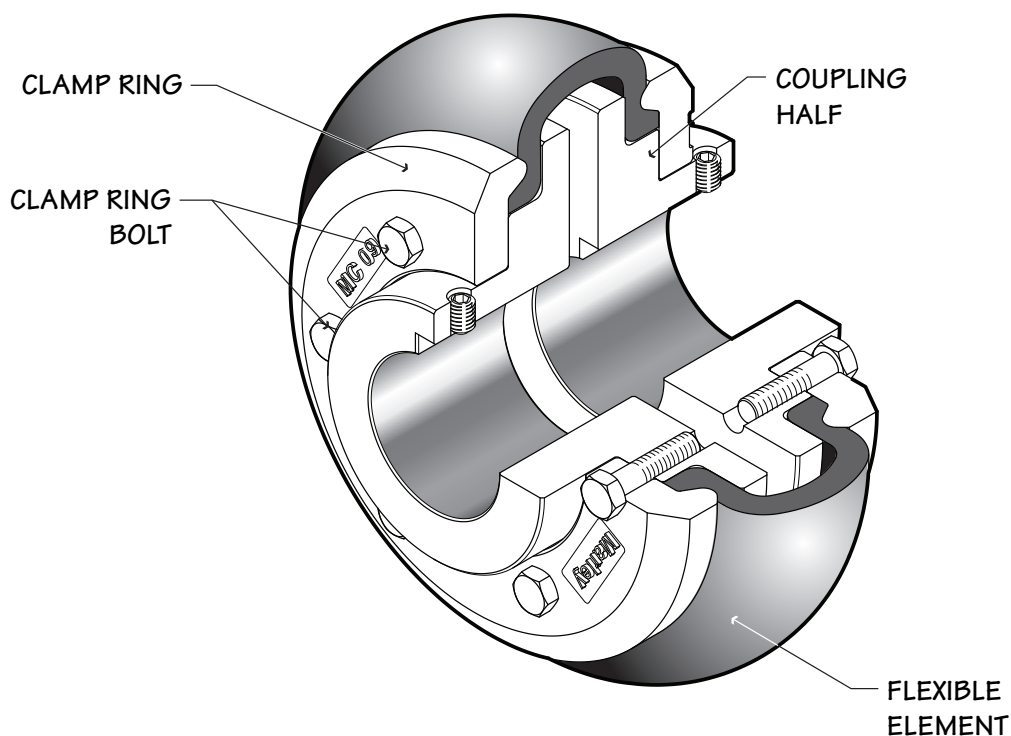

Assembly and Alignment

1. Inspect and clean motor and Geareducer® shafts. Remove any burrs on shafts with emery cloth or a fine file. Remove all lubricants from coupling bores and mating surfaces. Install keys in motor and Geareducer shaft keyways.
2. Install a clamp ring on each coupling half using the bolts provided.
 Note: Leave this attachment loose for now, only engaging a few threads of each bolt—it may be necessary to reposition the clamp rings for parallel alignment—Step 7.
 Caution: Do not lubricate bolt threads.
3. Slip each coupling half onto its mating shaft. Move the motor and Geareducer into place.
 Note: Clamp ring must be mounted to coupling half before the motor and Geareducer are positioned.
4. Check coupling spacing by measuring dimension “C” at the top of the coupling only. Refer to Table and Detail 1. Slide the coupling halves along the shafts to obtain spacing. The maximum distance between shaft ends is 51mm. The shafts may protrude through the coupling halves if necessary.
5. Tighten each set screw on its key—32.5 N·m.

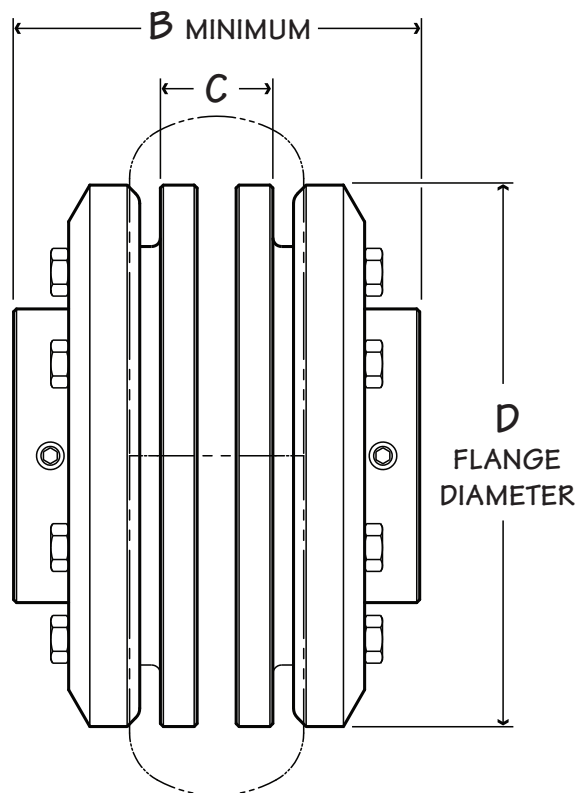

Detail 1

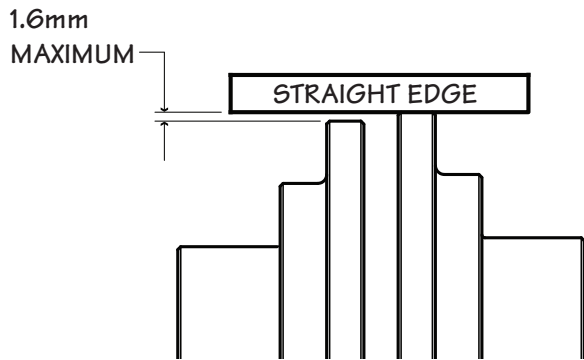

Detail 2

6. Check angular alignment by measuring the “C” dimension at 90° intervals (take at least four measurements). The total difference between any two measurements, C max – C min, must not exceed 1.6mm. See Detail 1.
7. Check parallel alignment by laying a straight edge across the outside of the coupling halves at several places around its circumference. Parallel misalignment may not exceed 1.6mm. See Detail 2.

Tip: If the clamp rings are larger in diameter than the coupling halves, remove enough clamp ring bolts to rotate the clamp rings so the straight edge bears directly on the coupling halves.

If measured misalignment is greater than 1.6mm, shim the motor and/or Geareducer mounting feet to obtain proper alignment. After adjusting shims, tighten the hold-down hardware and check alignment. Repeat the procedure until proper alignment is achieved. The best alignment is achieved when the straight edge is in contact with the coupling halves at four points as shown in Detail 2.

8. With clamp ring bolts holding the clamp ring(s) in

place, wrap the flexible element around the clamp rings as shown. Make sure the beads of the element are fully worked down into the seats.

9. Hold the split of the flexible element closed. A 3mm maximum gap is allowable. Tighten one or two bolts directly opposite the split—enough to hold the flexible element in place. Using both hands, knead the rubber element toward the split. Hold split closed and tighten the next two bolts farthest from split—enough to hold the flexible element in place. Repeat this procedure on all remaining flange bolts. Retighten each bolt in the order shown in Detail 3 using a torque specified in table.

Note: MC07 couplings have 5 bolts/half, use a similar cross pattern.

Tighten all bolts a second time to the specified torque.

Caution: Do not over-torque bolts or you may damage the clamp ring.

Maintenance

1. Marley SofTork couplings do not require lubrication.
2. Thoroughly inspect the coupling at least every six months. Check for looseness of set screws and coupling halves on shafts, and for wear of the flexible element.
3. Contact your Marley sales representative if you need replacement parts. Call 44 1905 750 270 or check the web at spxcooling.com to locate your nearest representative.

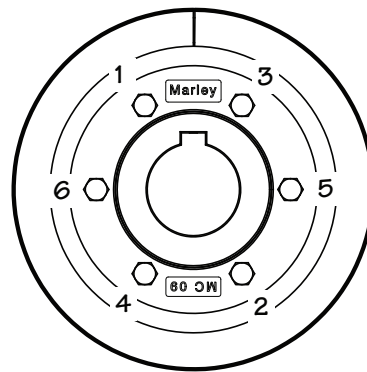

Detail 3

Coupling	B	C	D	Torque N · m	Cap Screw
MC07	130mm	38mm	143mm	32.5	5/16" x 1 1/2"
MC09	141mm	39mm	187mm	54	3/8" x 1 1/2"
MC11	162mm	40mm	233mm	54	3/8" x 1 1/2"
MC12	175mm	45mm	257mm	122	1/2" x 1 1/2"

SPX COOLING TECHNOLOGIES UK LTD

3 KNIGHTSBRIDGE PARK
WORCESTER WR4 9FA UK
44 1905 750 270 | ct.fap.emea@spx.com
spxcooling.com

uk_Z0592740_B | ISSUED 02/2019
© 2007-2019 SPX COOLING TECHNOLOGIES, INC. | ALL RIGHTS RESERVED
In the interest of technological progress, all products are subject to design and/or material change without notice.

